

Gruppe
Group **A/B**

Testblatt nach Anhang J des Internationalen Automobil-Sportgesetzes
Homologation form in accordance with appendix J of the international sporting code

Homologation gültig ab -1 MAR.1982 in Gruppe B
Homologation valid as from _____ in group _____

Foto A
Photo A



Foto B
Photo B

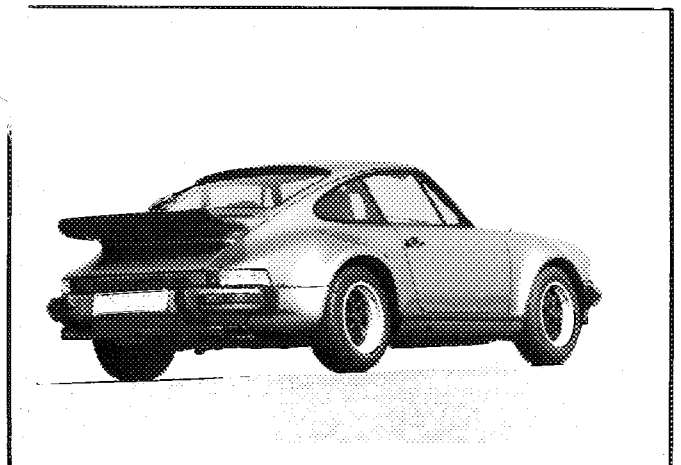

1. Definitionen
Definitions

101. Hersteller Dr. Ing. h. c. F. Porsche AG
Manufacturer _____

102. Handelsbezeichnung — Typ und Modell 911 Turbo
Commercial name(s) — Type and model _____

103. Gesamthubraum (2993) x 1,4 = 4190 ccm
Cylinder capacity _____

104. Art der Konstruktion getrennt, Material des Chassis
Type of car construction Separate, material of chassis _____

selbsttragend, Material der Karosserie Stahl / steel
Unitary construction _____

105. Anzahl der Volumina 2
Number of volumes _____

106. Anzahl der Sitzplätze 2 + 2
Number of places _____

Unterschrift und Stempel
der Nationalen Sporthoheit
Signature and stamp
of national sporting authority

Unterschrift und Stempel
der FISA
Signature and stamp
of FISA

Marke Porsche
Make

Modell: 911 Turbo
Model

Homologation Nr. B-208
Homologation Nr.

2. Abmessungen — Gewichte

Dimensions — weights

202. Länge über alles 4291 mm $\pm 1\%$
Overall length
203. Breite über alles 1775 mm $\pm 1\%$ Meßpunkt an der Hinterachse
Overall width Where measured
at rear axle
204. Karosseriebreite: a) Vorderradmitte 1700 mm $\pm 1\%$
Width of bodywork: At front axle
b) Hinterradmitte 1775 mm $\pm 1\%$
At rear axle
206. Radstand: a) Rechts 2272 mm $\pm 1\%$ b) Links 2272 mm $\pm 1\%$
Wheelbase: Right Left
209. Überhang: a) Vorne 932 mm $\pm 1\%$ b) Hinten 1087 mm $\pm 1\%$
Overhang: Front Rear
210. Entfernung „G“ (Lenkrad-hintere Trennwand) 1380 mm $\pm 1\%$
Distance „G“ (steering wheel — rear bulkhead)

3. Motor (Für Kreiskolbenmotor siehe Artikel 335 auf Nachtragsblatt)

Engine (in case of rotative engine, see Article 335 on complementary form)

301. Einbauort und Lage des Motors hinten / rear, längs 0° / longitudinal 0°
Location and position of the engine
303. Arbeitsverfahren Viertakt Otto-Motor / four-stroke Otto engine
Cycle
304. Aufladung ja / yes Typ Abgasturbolader / exhaust turbo charger
Supercharging yes ~~no~~ Type
(Bei Aufladung siehe auch Artikel 334 auf Nachtragsblatt)
(In case of supercharging see also Article 334 on complementary form)
305. Anzahl und Anordnung der Zylinder 6 Zylinder-Boxermotor / 6 cylinder Boxer engine
Number and layout of the cylinders
306. Kühlsystem luftgekühlt / air-cooled
Cooling system
307. Hubraum: a) Pro Zylinder 498,8 ccm b) Gesamt 2993 ccm
Cylinder capacity: a) Unitary Total:
c) Maximal zulässiger Hubraum* 3032 x 1,4 ccm
c) Maximum total allowed* = 4244,8

* (Diese Angabe gilt nicht für Gruppe N)
* (This indication is not to be considered in Group N)

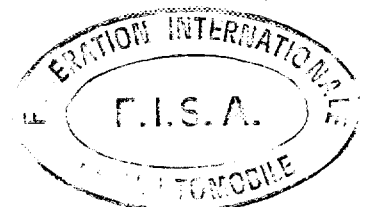

Marke Porsche Modell 911 Turbo Homologation Nr. B-208
Make _____ Model _____ Homologation Nr. _____

312. Material des Zylinderblocks Leichtmetall / light alloy
Cylinder block material: _____

313. Laufbuchsen: a) ja / ~~nein~~ nein c) Typ Einzelzylinder
Sleeves: yes/no no Type single piece cylinder

314. Bohrung 95 mm
Bore _____

315. Maximal zulässige Bohrung 95,6 mm (Diese Angabe gilt nicht für Gruppe N)
Maximum bore allowed _____ (This indication is not to be considered in Group N)

316. Hub 70,4 mm
Stroke _____

318. Pleuel: a) Material Stahl / steel b) Art des Pleuefußes geteilt / split bearing
Connecting rod: a) Material _____ b) Big end type _____

c) Innerer Durchmesser des Pleuefußes (ohne Lager) 56 mm $\pm 1\%$
Interior diameter of the big end (without bearings) _____

d) Länge zwischen den Achsen 127,8 mm ($\pm 0,1$ mm) e) Mindestgewicht 600 g
Length between the axes _____ Minimum weight _____

319. Kurbelwelle: a) Herstellungsart geschmiedet, einteilig / forged, single piece
Crankshaft: type of manufacture _____

b) Material Stahl / steel
Material _____

c) gegossen geschmiedet d) Anzahl der Kurbelwellen-Hauptlager 8
moulded stamped Number of bearings _____

e) Art der Kurbelwellen-Hauptlager Gleitlager / slide bearing
Type of bearings _____

f) Durchmesser der Kurbelwellen-Hauptlager 57 mm $\pm 0,2\%$
Diameter of bearings _____

g) Material der Lagerdeckel _____
Bearing caps material _____

h) Mindestgewicht der Kurbelwelle (allein) 11800 g
Minimum weight of the bare crankshaft _____

320. Schwungrad: a) Material Stahl / steel
Flywheel: Material _____

b) Mindestgewicht mit Anlaßzahnkranz 3600 g
Minimum weight of the flywheel with starter ring _____

321. Zylinderkopf: a) Anzahl der Zylinderköpfe 6 b) Material Leichtmetall / light alloy
Cylinder head: Number of cylinder heads _____ Material _____

323. Kraftstoffzufuhr durch Vergaser: a) Anzahl der Vergaser _____
Fuel feed by carburettor(s): Number of carburettors _____

b) Typ _____ c) Marke und Modell _____
Type _____ Marke and model _____

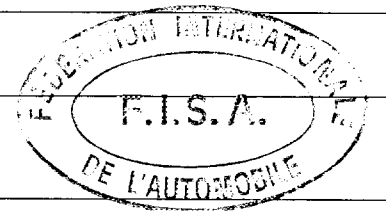

Marke Porsche
Make

Modell 911 Turbo
Model:

Homologation Nr. B-208
Homologation Nr.

d) Anzahl der Gemischdurchlässe je Vergaser _____
Number of mixture passages per carburettor

e) Maximaler Durchmesser der Gemischöffnung am Vergaserausgang _____ mm
Maximum diameter of the flange hole of the carburettor exit port

f) Durchmesser des Lufttrichters am engsten Punkt _____ mm
Diameter of the venturi at the narrowest point

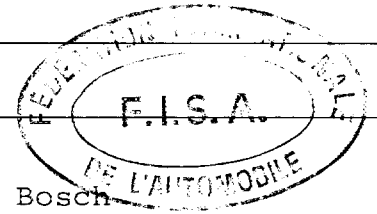

324. Kraftstoffzufuhr durch Einspritzung
Fuel feed by injection:

a) Hersteller Bosch
Manufacturer

b) Modell des Einspritzsystems K-Jetronic
Model of injection system

c) Art der Kraftstoffdosierung mechanisch elektronisch hydraulisch
Kind of fuel measurement mechanical electrical hydraulic

c1) Kolbenpumpe ja / nein
Piston pump yes/no

c2) Luftvolumenmessung ja / nein
Measurement of air volume yes/no

c3) Luftmassenmessung ja / nein
Measurement of air mass yes/no

c4) Luftgeschwindigkeitsmessung ja / nein
Measurement of air speed yes/no

c5) Luftdruckmessung ja / nein
Measurement of air pressure yes/no

Welcher Druck wird zur Messung herangezogen? _____ bar
Which pressure is taken for measurement?

d) Abmessungen der Drosselklappe(n) oder der/des Schieber(s) 63 mm
Effective dimensions of measure position in the throttle area

e) Anzahl der effektiven Kraftstoffauslässe 6
Number of effective fuel outlets

f) Lage der Einspritzventile Saugrohr Zylinderkopf
Position of injection valves inlet manifold cylinderhead

g) Teile des Einspritzsystems, die zur Kraftstoffdosierung dienen: Warmlaufregler + Mengenteiler
Statement of fuel measuring parts of injection system: heat up regulator + flow distributor

325. Nockenwelle: a) Anzahl 2
Camshaft: Number

b) Lage OHC
Location

c) Art des Antriebs Ketten / by chain d) Anzahl der Lager pro Nockenwelle 4
Driving system Number of bearings for each shaft

f) Art der Ventilbetätigung über Kipphebel / by toggle switch
Type of valve operation

326. Steuerung: e) Maximaler Ventilhub
Timing: Maximum valve lift:

Einlaß 9,7 mm Auslaß 8,9 mm
Inlet Exhaust

Mit einem Spiel von 0,1 mm 0,1 mm
With clearance

327. Einlaß: a) Material des Ansaugkrümmers Leichtmetall / light alloy
Inlet: Material of the manifold

b) Anzahl der Ansaugkrümmerelemente 1 c) Anzahl der Ventile pro Zylinder 1
Number of manifold elements Number of valves per cylinder

d) Maximaler Durchmesser der Ventile 49 mm e) Durchmesser des Ventilschafts 9,0 mm
Maximum diameter of the valves Diameter of the valve stem

f) Länge des Ventils 110,1 ± 0,25 mm g) Art der Ventilsfeder Schraubenfeder/coil spring
Length of the valve Type of valve springs

Marke Porsche Modell 911 Turbo Homologation Nr. B-208
Make Model Homologation Nr.

328. Auslaß: a) Material des Auslaßkrümmers Stahl / steel
Exhaust. Material of the manifold
b) Anzahl der Auslaßkrümmerelemente 2 d) Anzahl der Ventile pro Zylinder 1
Number of manifold elements Number of valves per cylinder
e) Maximaler Durchmesser der Ventile 41,5 mm f) Durchmesser des Ventilschafts 9,0 mm
Maximum diameter of the valves Diameter of the valve stem
g) Länge des Ventils 108,4 ± 0,25 mm h) Art der Ventilsfeder Schraubenfeder
Length of the valve Type of valve springs coil spring

330. Zündanlage: a) Art BHKZ Batterie / battery
Ignition system: Type
b) Anzahl der Kerzen pro Zylinder 1 c) Anzahl der Verteiler 1
Number of plugs per cylinder Number of distributors

333. Schmiersystem: a) Art Trockensumpf b) Anzahl der Ölpumpen 1
Lubrication system: Type dry sump Number of oil pumps

4. Kraftstoffanlage

Fuel circuit

401. Tank: a) Anzahl 1 b) Lage vorn im Kofferraum
Fuel tank: Number Location in trunk (front)
c) Material Stahl / steel d) Maximaler Inhalt 80,0 Liter
Material: Maximum capacity litre

5. Elektrische Ausrüstung

Electrical equipment

501. Batterie(n): a) Anzahl 1
Batteries: Number

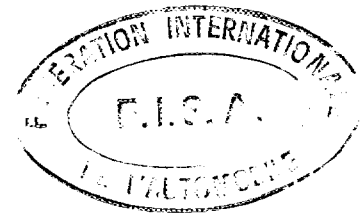

6. Kraftübertragung

Drive

601. Antriebsräder vorn hinten
driving wheels: front rear

602. Kupplung: b) Art der Betätigung durch Kabel / by cable
Clutch: Drive system
c) Anzahl der Scheiben 1
Number of plates

Marke Porsche
 Make

Modell 911 Turbo
 Model

Homologation Nr. B-208
 Homologation Nr.

603. Getriebe: a) Lage vor dem Motor / in front of the engine
 Gear-box Location

b) Manuelles Getriebe, Marke Porsche c) Automatisches Getriebe, Marke _____
 „Manual“ make „Automatic“ make

d) Anordnung des Gangschalthebels auf Mitteltunnel / on transmission tunnel
 Location of the gear lever

e) Übersetzungen
 Ratios

	Handschtaltung Manual			Automatik Automatic			Zusätzl. Getriebe Additional G.P.		
	Über- setzungen ratio	Anzahl der Zähne number of teeth	synchro	Über- setzungen ratio	Anzahl der Zähne number of teeth	synchro	Über- setzungen ratio	Anzahl der Zähne number of teeth	synchro
1	2,250	36/16	x				1,833	33/18	x
2	1,3043	30/23	x				1,208	29/24	x
3	0,8929	25/28	x				0,929	26/28	x
4	0,6563	21/32	x				0,733	22/30	x
5									
Rück- wärts R	2,4375	39/16					2,4375	39/16	
Kon- stante Con- stant	--	--					--	--	

f) Schalt-Schema
 Gear change gate

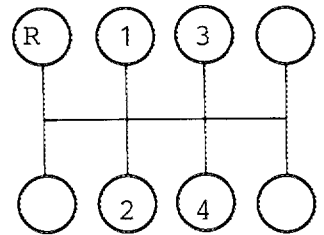
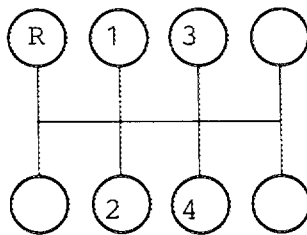

604. Schnellgang: a) Art _____
 Overdrive Type

b) Übersetzung _____ c) Anzahl der Zähne _____
 Ratio Number of teeth

d) Vorwärtsgänge, zu denen der Schnellgang zugeschaltet werden kann _____
 Usuable with the following gears



Marke Porsche
Make

Modell 911 Turbo
Model

Homologation Nr. B-208
Homologation Nr.

605. Antriebsachse
Final drive

Vorn Front	Hinten Rear
	<u>Kegeltellerrad/bevel gear</u>
	<u>4,222</u>
	<u>9 : 38</u>
	<u>limited slip</u>

- a) Art des Achsantriebs
Type of final drive
- b) Übersetzungsverhältnis
Ratio
- c) Anzahl der Zähne
Number of teeth
- d) Art des Sperrdifferentials
(wenn vorhanden)
Type of differential limitation
(if provided)

e) Übersetzungsverhältnis des Verteilergetriebes
Ratio of the transfer box

606. Art der Gelenkwelle Doppelgelenkwellen / double joint shafts
Type of transmission shaft

7. Radaufhängung Suspension:

701. Art der Radaufhängung: a) Vorn McPherson Federbein / McPherson strut
Type of suspension Front

b) Hinten Schräglenker / trailing arm
Rear

702. Schraubenfedern: Vorn: ~~ja~~/nein Front: ~~yes~~/no
Helicoidal springs: Rear: ~~ja~~/nein Rear: ~~yes~~/no

703. Blattfedern: Vorn: ~~ja~~/nein Front: ~~yes~~/no
Leaf springs: Rear: ~~ja~~/nein Rear: ~~yes~~/no

704. Drehstab: Vorn: ja / ~~nein~~ Front: yes / ~~no~~
Torsion bar: Rear: ja / ~~nein~~ Rear: yes / ~~no~~

705. Andere Arten der Radaufhängung: s. Bild / Zeichnung auf Seite 15
Other type of suspension: See photo or drawing on page 15



Marke Porsche
 Make

Modell 911 Turbo
 Model

Homologation Nr. B-208
 Homologation Nr.

707. Stoßdämpfer
 Shock absorbers

Vorn Front	Hinten Rear
a) Anzahl je Rad Number per wheel: <u>1</u>	a) Anzahl je Rad Number per wheel: <u>1</u>
b) Art Type: <u>Teleskop/telescopic</u>	b) Art Type: <u>Teleskop/telescopic</u>
c) Funktionsprinzip Working principle: <u>hydraulisch/hydraulic</u>	c) Funktionsprinzip Working principle: <u>hydraulisch/hydraulic</u>

8. Fahrwerk
 Running gear

801. Räder:
 Wheels: a) Durchmesser Vorn 15 " / 381 / mm Hinten 15 " / 381 / mm
 Diameter Front Rear Bore

803. Bremsen:
 Brakes: a) Bremssystem hydraulische Zweikreisbremse
 Braking system hydraulic double circuit brake

b) Anzahl der Hauptzylinder 1 Tandem b1) Bohrung 20,64 mm
 Number of master cylinders Bore

c) Servo-Bremse ja / ~~nein~~ c1) Marke und Art 7" Vakuum Teves / vacuum Teves
 Power assisted brakes yes/no Make and type

d) Bremskraftregler xx / nein d1) Lage vorn im Kofferraum
 Braking adjuster yes/no Location in trunk (front)

Vorn Front	Hinten Rear
e) Anzahl der Zylinder je Rad Number of cylinders per wheel: <u>2</u>	e) Anzahl der Zylinder je Rad Number of cylinders per wheel: <u>2</u>
1) Bohrung Bore: <u>48</u> mm	1) Bohrung Bore: <u>38</u> mm
f) Trommelbremsen Drum brakes	
1) Innendurchmesser Interior diameter: _____ mm (± 1,5 mm)	1) Innendurchmesser Interior diameter: _____ mm (± 1,5 mm)
2) Anzahl der Bremsbacken je Rad Number of shoes per wheel: _____	2) Anzahl der Bremsbacken je Rad Number of shoes per wheel: _____
3) Bremsfläche Braking surface: _____ qcm	3) Bremsfläche Braking surface: _____ qcm
4) Breite der Bremsbeläge Width of the shoes: _____ mm	4) Breite der Bremsbeläge Width of the shoes: _____ mm
g) Scheibenbremsen Disc brakes	
1) Anzahl der Bremsbeläge je Rad Number of pads per wheel: <u>2</u>	1) Anzahl der Bremsbeläge je Rad Number of pads per wheel: <u>2</u>
2) Anzahl der Sättel je Rad Number of calipers per wheel: <u>1</u>	2) Anzahl der Sättel je Rad Number of calipers per wheel: <u>1</u>



Marke Porsche
 Make

Modell 911 Turbo
 Model

Homologation Nr. B-208
 Homologation Nr.

	Vorn Front	Hinten Rear
3) Material der Bremssättel Caliper material	<u>Leichtmetall/light alloy</u>	<u>Stahl / steel</u>
4) Maximale Dicke der Scheibe Maximum disc thickness	<u>20,5</u> mm	<u>20,0</u> mm
5) Außendurchmesser der Scheibe Exterior diameter of the disc	<u>282,5</u> mm (± 1 mm)	<u>290,0</u> mm (± 1 mm)
6) Außendurchmesser der Belagfläche Exterior diameter of the shoes rubbing surface	<u>280,6 + 2,3</u> mm	<u>288,1 + 2,3</u> mm
7) Innendurchmesser der Belagfläche Interior diameter of the shoes rubbing surface	<u>170,0 + 2,2</u> mm	<u>202,4 + 2,8</u> mm
8) Länge der Beläge über Alles Overall length of the shoes	<u>76,5</u> mm	<u>61,5</u> mm
9) Belüftete Scheiben Ventilated disc	ja / nein yes/ no	ja / nein yes/ no
10) Bremsfläche je Rad Braking surface per wheel	<u>782,4</u> qcm	<u>660,0</u> qcm

h) Feststellbremse
 Parking brake

1) Betätigungssystem mechanisch/mechanical
 Command system

2) Lage des Bremshebels auf Mittelstunnel
 Location of the lever on transmission tunnel

3) Wirkung auf die Räder ~~Vorne~~ Hinten
 On which wheels ~~XXXX~~ Rear

804. Lenkung: a) Art: Zahnstangenlenkung / rack and pinion steering
 Type

b) Übersetzungsverhältnis 17,78 : 1
 Ratio

c) Lenkhilfe ~~ja~~ / nein
 Power assisted ~~XXXX~~ no

9. Karosserie
 Bodywork

901. Innen: a) Belüftung ~~ja~~ / ~~nein~~
 Interior: Ventilation ~~XXXX~~ ~~XXXX~~

b) Heizung ~~ja~~ / ~~nein~~
 Heating ~~XXXX~~ ~~XXXX~~

f) Sonderausstattung Schiebedach ~~ja~~ / ~~nein~~
 Sun roof optional ~~XXXX~~ ~~XXXX~~

1) Art Schiebedach /
 Type sliding roof

2) Betätigungssystem elektrisch / electrical
 Command system

g) Öffnungssystem der Seitenscheiben:
 Opening system for the side windows

Vorn durch Kurbelapparat oder
 Front elektrisch
 Hinten by mechanical or electrical
 Rear operation

902. Außen: a) Anzahl der Türen 2
 Exterior: Number of doors

b) Heckklappe ~~ja~~ / nein
 Rear tailgate ~~XXXX~~ ~~XXXX~~

c) Material der Türen
 Door material:

Vorn Stahl / steel
 Front
 Hinten
 Rear:

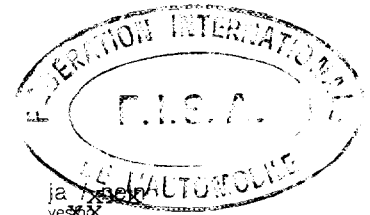

Marke Porsche
Make

Modell 911 Turbo
Model

Homologation Nr. B-208
Homologation Nr.

Fotos
Photos

Motor
Engine

C) Rechte Seitenansicht Motor (ausgebaut)
Right hand view of dismantled engine

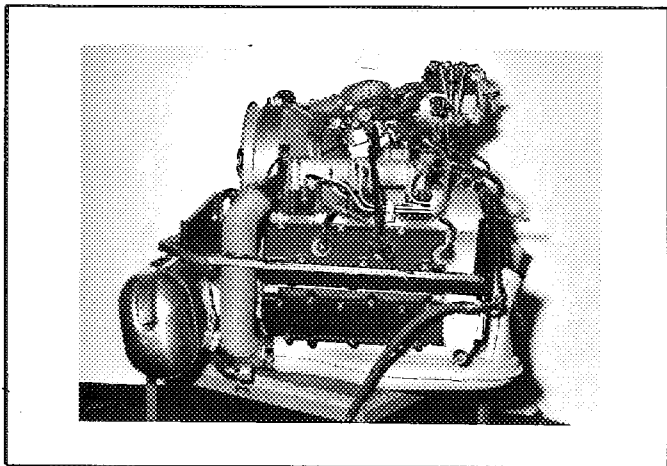

D) Linke Seitenansicht Motor (ausgebaut)
Left hand view of dismantled engine

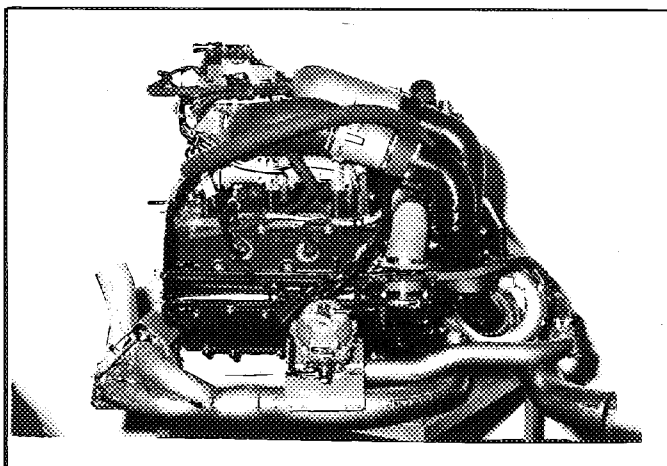

E) Motor im Motorraum
Engine in its compartment

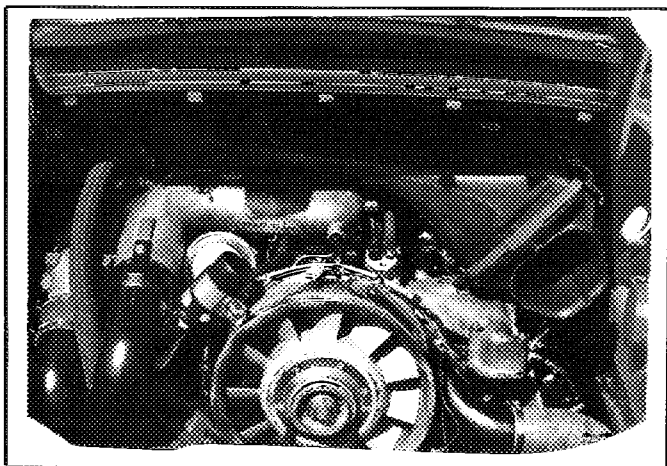

F) Zylinderkopf allein
Bare cylinderhead

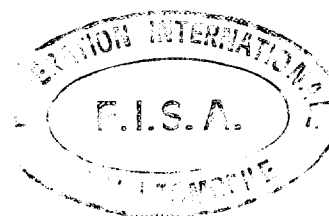
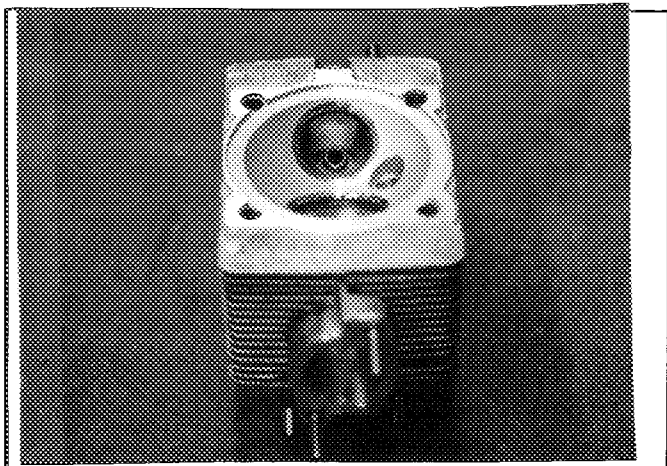

G) Verbrennungsraum
Combustion chamber

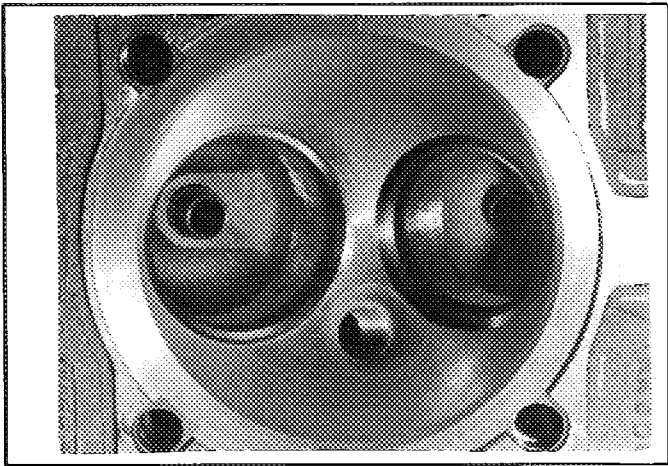

H) Vergaser oder Einspritzsystem
Carburetor(s) or injection system

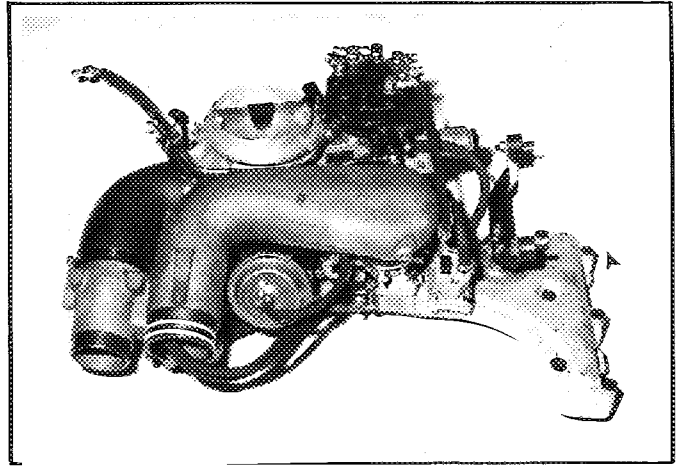

I) Einlaßkrümmer
Inlet manifold

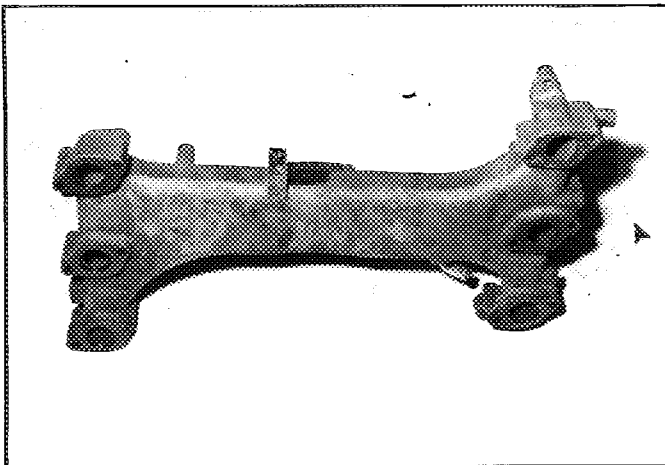

J) Auspuffkrümmer
Exhaust manifold

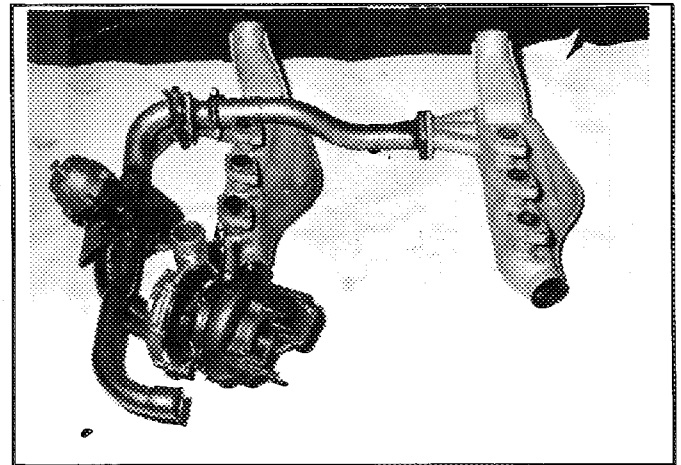

Getriebe
Transmission

S) Getriebegehäuse und Kupplungsglocke
Gearbox casing and clutch bellhousing

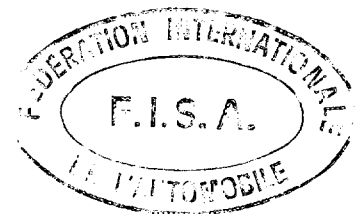
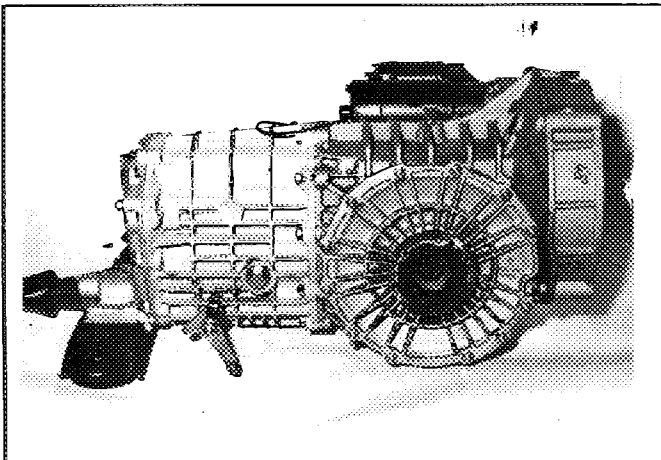

Marke Porsche
Make

Modell 911 Turbo
Model

Homologation Nr. B-208
Homologation Nr.

Radaufhängung
Suspension

T) Vorderachse vollständig ausgebaut
Complete dismantled front running gear

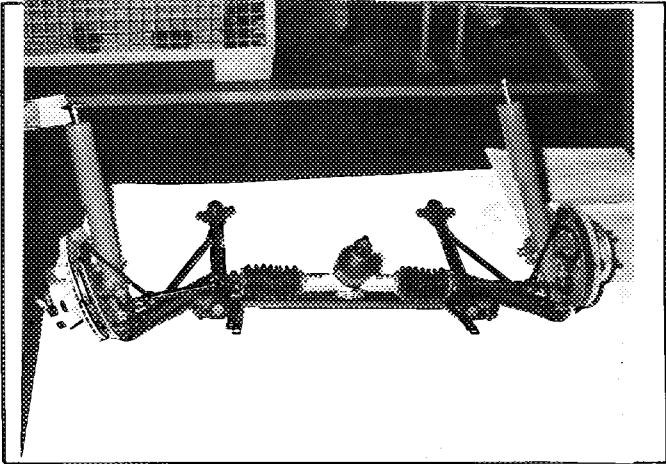

U) Hinterachse vollständig ausgebaut
Complete dismantled rear running gear

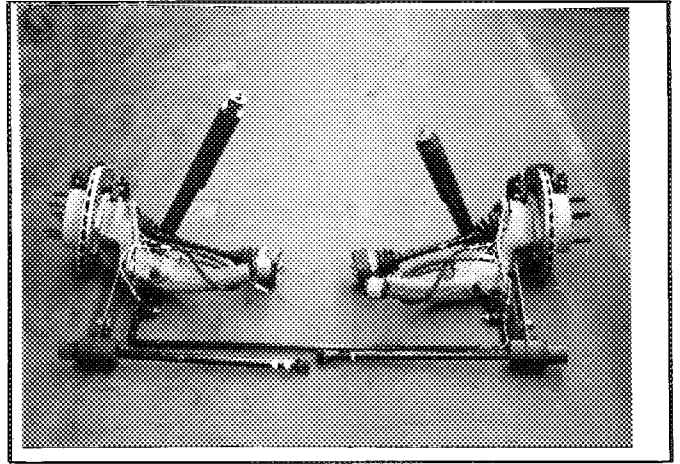

Fahrwerk
Running gear

V) Bremsen vorn
Front brakes

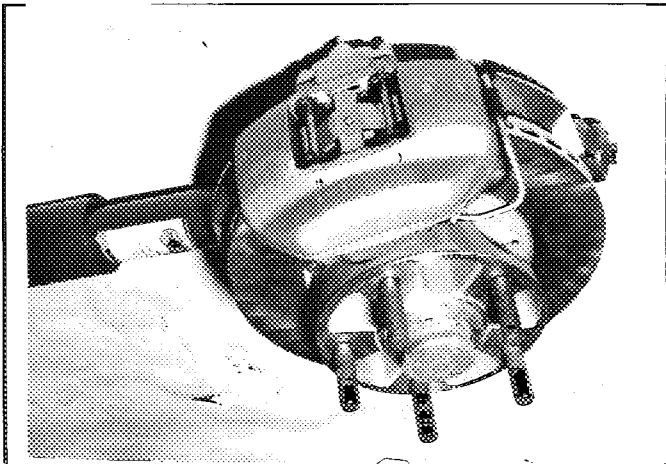

W) Bremsen hinten
Rear brakes

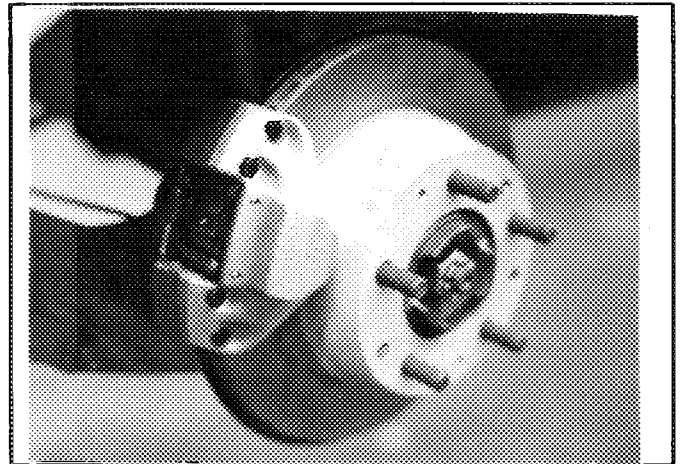

Karosserie
Bodywork

X) Armaturenbrett
Dashboard

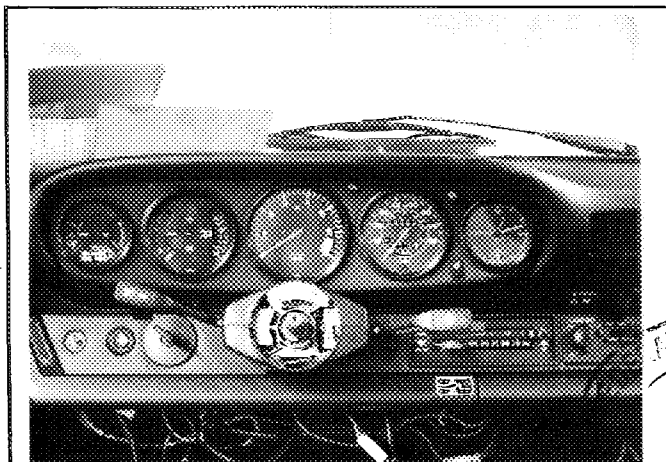

Y) Schiebedach
Sunroof



Zeichnungen
Drawings

Motor
Engine

I. Einlaßöffnungen im Ansaugkrümmer (Abmessungstoleranzen: -2% , $+4\%$)
Cylinderhead inlet ports, manifold side — tolerances on dimensions: -2% , $+4\%$

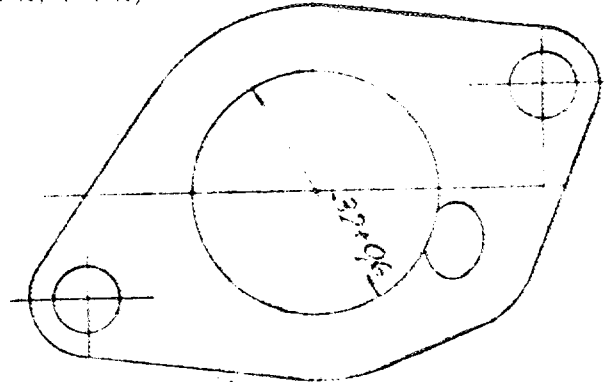

II. Einlaßöffnungen im Zylinderkopf (Abmessungstoleranzen: -2% , $+4\%$)
Inlet manifold ports, cylinderhead side — tolerances on dimensions: -2% , $+4\%$

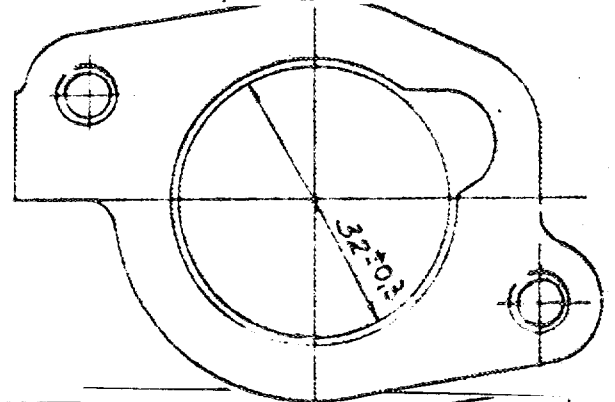

III. Auslaßöffnungen im Auspuffkrümmer (Abmessungstoleranzen: -2% , $+4\%$)
Cylinderhead exhaust ports, manifold side — tolerances on dimensions: -2% , $+4\%$

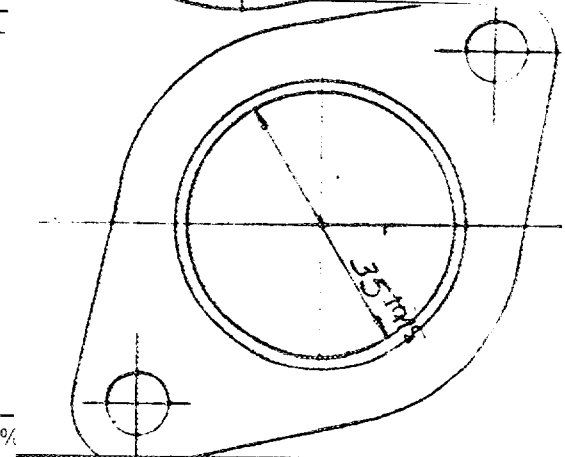

IV. Auslaßöffnungen im Zylinderkopf (Abmessungstoleranzen: -2% , $+4\%$)
Exhaust manifold ports, cylinderhead side — tolerances on dimensions: -2% , $+4\%$

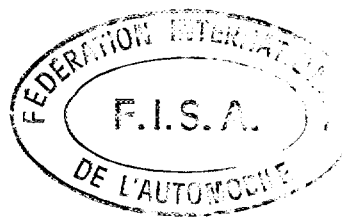
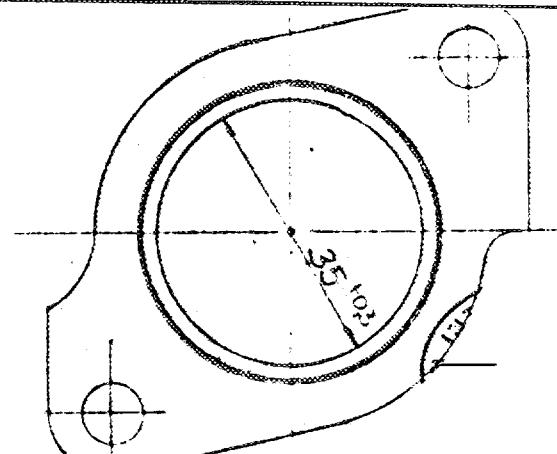

Gruppe
Group **A/B**

Marke Dr.-Ing.h.c.F.Porsche AG
Make

Modell 911 Turbo
Model

Innenabmessungen gem. Homologationsbestimmungen
Interior dimensions as defined by the Homologation Regulations

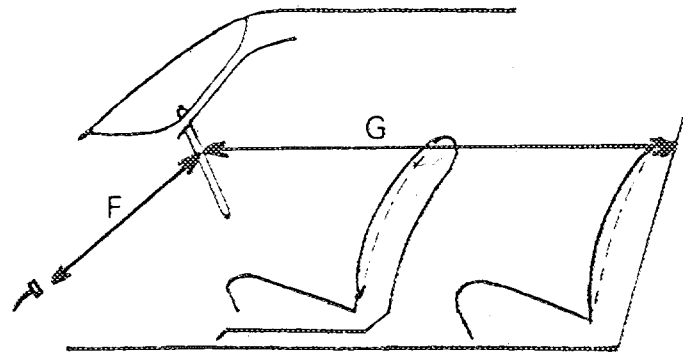
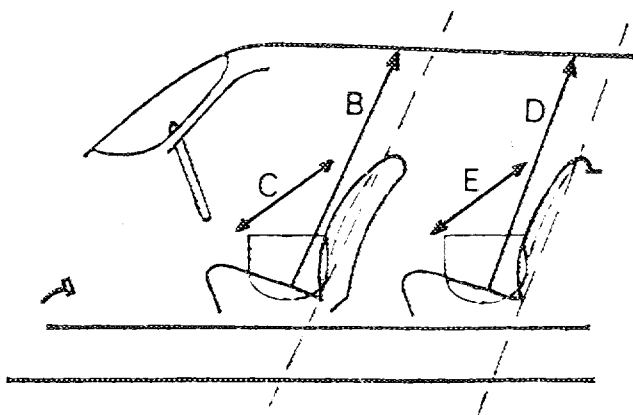

- B Höhe über den Vordersitzen: 925 mm
Height above front seats
- C Breite über den Vordersitzen: 1230 mm
Width at front seats
- D Höhe über den Rücksitzen: 831 mm
Height above rear seats
- E Breite über den Rücksitzen: 1190 mm
Width at rear seats
- F Abstand Lenkrad — Bremspedal: 578 mm
Steering wheel — brake pedal
- G Abstand Lenkrad — Hintere Trennwand: 1380 mm
Steering wheel — rear bulkhead
- H = F + G = 1958 mm

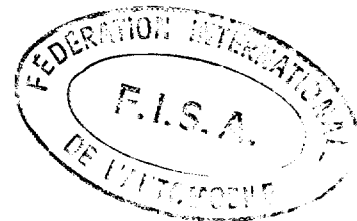

Nachtrag zum offiziellen Testblatt der FISA

Form of extension to the official FISA-Homologation

ET Normale Weiterentwicklung des Typs: ab Fahrgestell -Nr.: _____
 Normal evolution of the type: as from chassis number

VF Liefervariante
Supply variant

VO Ausstattungsvariante
Option variant

ER Berichtigung
Erratum



Homologation gültig ab: _____ -1.MAR.1982 _____ in Gruppe: B
 Homologation valid as from _____ in group

Hersteller: Dr. Ing. h. c. F. Porsche AG Modell und Typ: 911 Turbo
 Manufacturer _____ Model and type

Seite od. Nachtrag Page or ext.	Artikei Art	Beschreibung Description
		Fotos Photos A + B + E + H + T + U + V + W + X + Y
S. 2	307a	Hubraum pro Zylinder Cylinder capacity, unitary 549,8 ccm
S. 2	b	Hubraum gesamt Cylinder capacity, total 3299,0 ccm x 1,4 = 4618,6
S. 2	c	Maximal zulässiger Hubraum Maximum total allowed 3339,0 ccm x 1,4 = 4674,6
S. 3	314	Bohrung / Bore 97,0 mm
S. 3	315	Maximal zulässige Bohrung Maximum bore allowed 97,6 mm
S. 3	316	Hub / Stroke 74,4 mm
S. 3	318c	Innerer Durchmesser des Pleuefußes (ohne Lager) Interior diameter of the big end (without bearings) 58,0 mm
S. 3	318d	Länge zwischen den Achsen Length between the axes 127,0 mm

Marke Porsche
 Make

Modell 911 Turbo
 Model

Homologations Nr. B-208
 Homologation Nr.

Nachtrag Nr. 01/01ET
 Ext. Nr.

Seite od. Nachtrag Page or ext.	Artikel Art	Beschreibung Description
S. 3	319f	Durchmesser der Kurbelwellen- Hauptlager 60,0 mm Diameter of bearings
S. 6	603e	Übersetzungen: 4. Gang nun 32/20 anstatt 32/12 Ratios: 4th speed now 32/20 instead of 32/12
S. 8	803c	Servo-Bremse 9" Vakuum Teves Power assisted brake vacuum Teves
S. 8	e	Anzahl der Zylinder je Rad 4 vorn 38, hinten 30 mm Number of cylinders per wheel 4 front 38, rear 30 mm
S. 9	g3	Material der Bremsättel Leichtmetall (vorn + hinten) Material of calipers Light alloy (front + rear)
S. 9	g4	Maximale Dicke der Scheibe vorn 32 mm hinten 28 mm Maximum disc thickness front 32 mm rear 28 mm
S. 9	g5	Außendurchmesser der Scheibe vorn 304 mm hinten 309 mm Exterior diameter of disc front 304 mm rear 309 mm
S. 9	g6	Außendurchmesser der Belag- fläche vorn 301,8 mm + 1,4 hinten 306,8 mm + 1,4 Exterior diameter of the front 301,8 mm + 1,4 shoes rubbing surface rear 306,8 mm + 1,4
S. 9	g7	Innendurchmesser der Belag- fläche vorn 197,8 mm + 1,8 hinten 202,8 mm + 0,8 Interior diameter of the front 197,8 mm + 1,8 shoes rubbing surface rear 202,8 mm + 0,8
S. 9	g8	Länge der Beläge über Alles vorn 97,8 mm hinten 97,8 mm Overall length of the shoes front 97,8 mm rear 97,8 mm
S. 9	g10	Bremsfläche je Rad vorn 832,48 cm² hinten 832,48 cm² Braking surface per wheel front 832,48 cm² rear 832,48 cm²



Marke Porsche
Make

Modell 911 Turbo
Model

Homologations Nr. B-208
Homologation Nr.

Fotos
Photos

Nachtrag Nr. 01/01ET
Ext. Nr.

Foto A



Foto B



Foto E

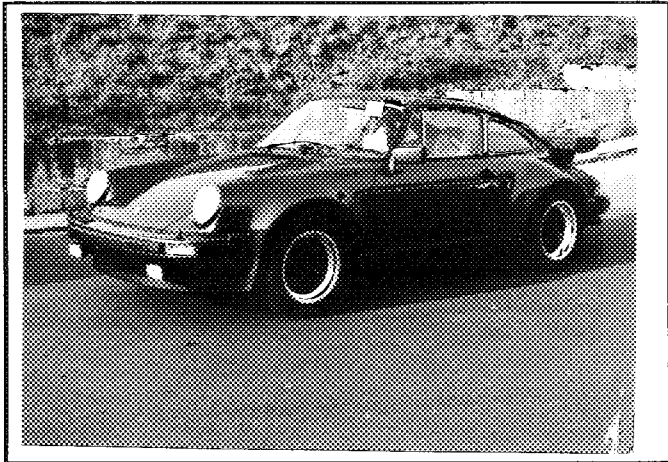

Foto H

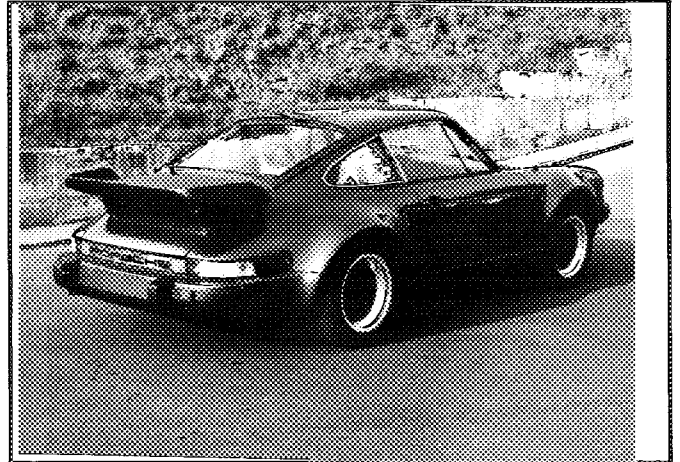

Foto T

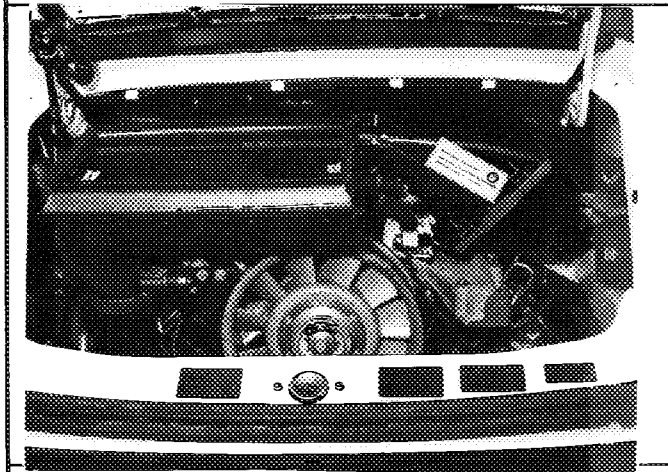

Foto U

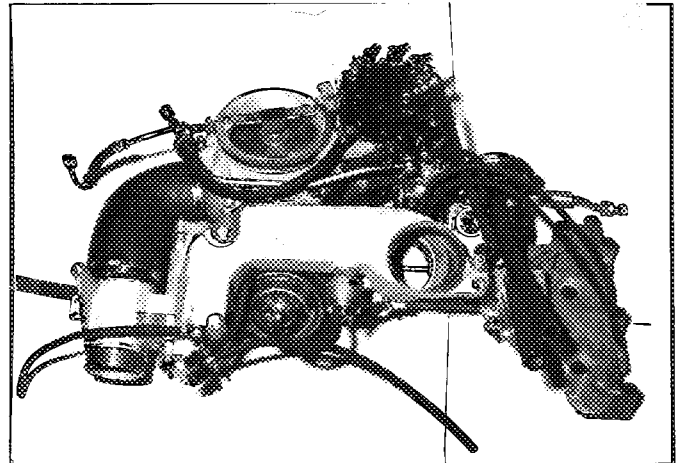

Fotos
Photos

Nachtrag Nr. 01/015T
Ext. Nr.

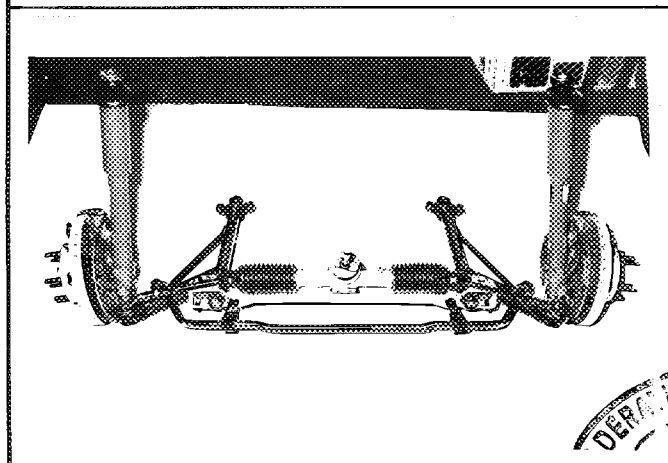
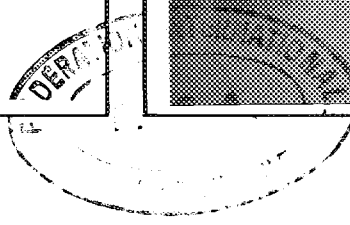
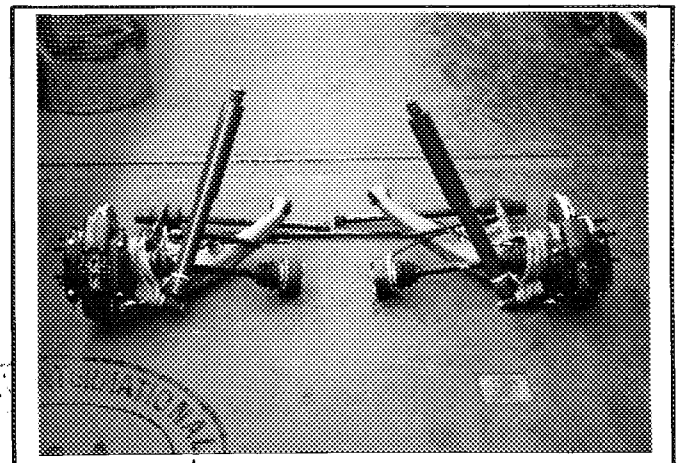
Foto V



Foto W



Foto X

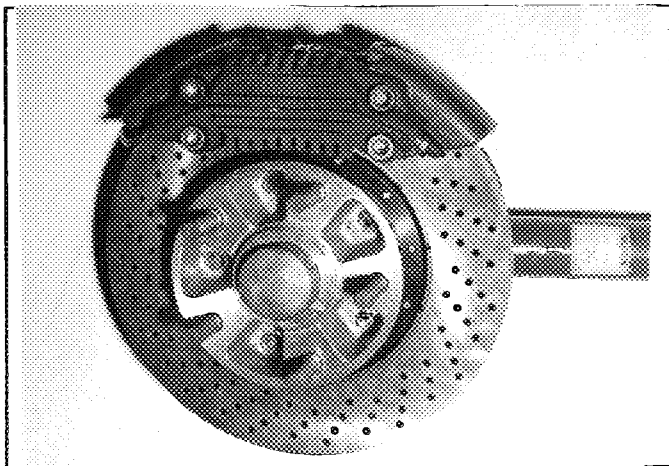

Foto Y

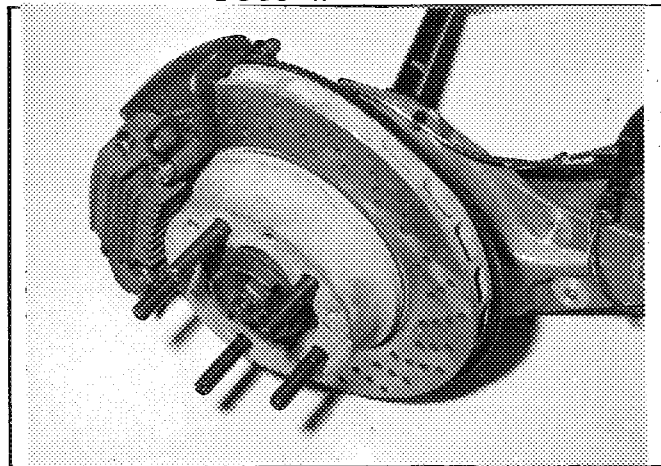

Foto C

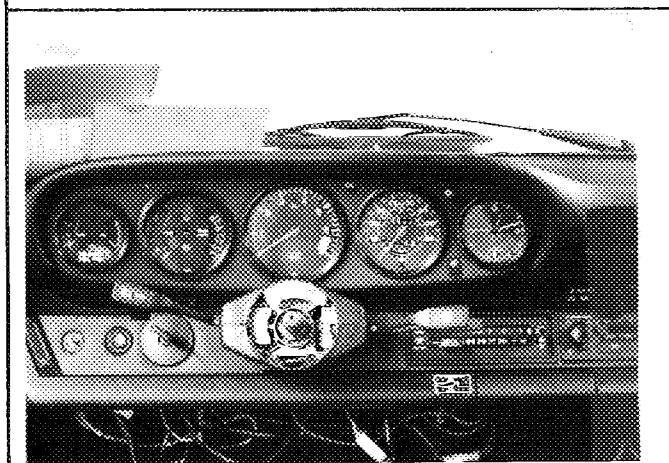

Foto D

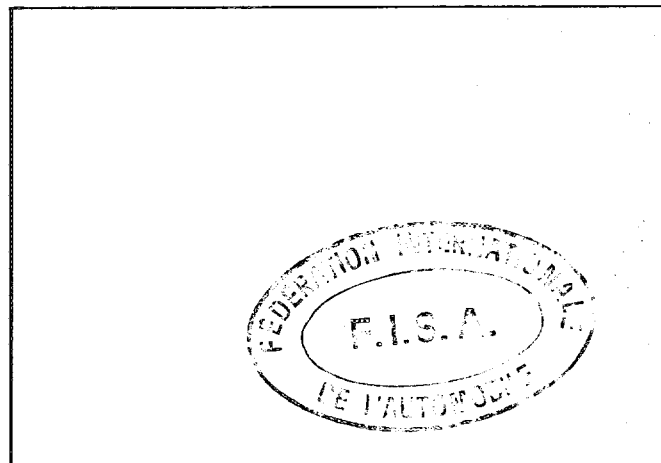

FÉDÉRATION INTERNATIONALE DU SPORT AUTOMOBILE

ONS Oberste Nationale Sportkommission für den Automobilsport in Deutschland GmbH

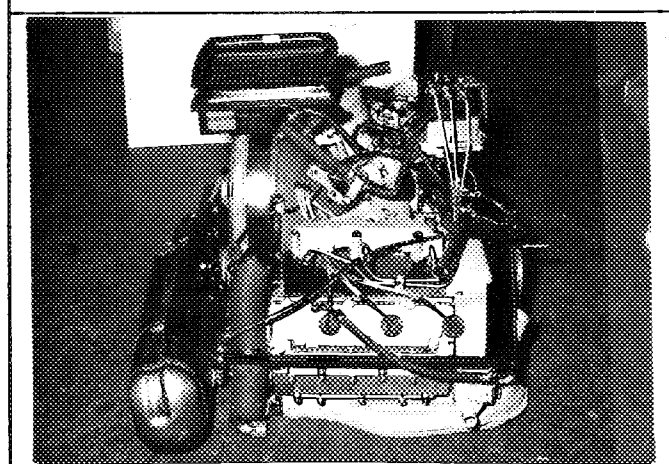
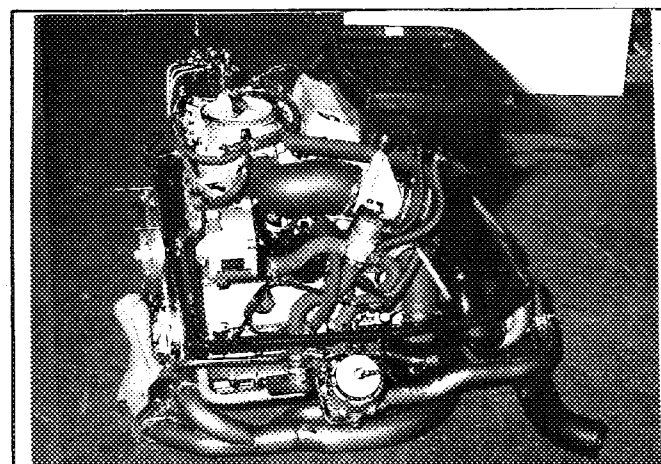
Homologation Nr.

B-208

Nachtrag Nr.
Extension Nr.

02/01 VO

Nachtrag zum offiziellen Testblatt der FISA

Form of extension to the official FISA-Homologation

ET Normale Weiterentwicklung des Typs: ab Fahrgestell-Nr.: _____
Normal evolution of the type, as from chassis number.

VF Liefervariante
Supply variant

VO Ausstattungsvariante
Option variant

ER Berichtigung
Erratum

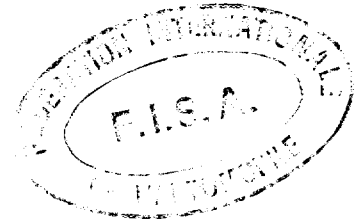

Homologation gültig ab: _____ -1 MAR 1962 _____ in Gruppe: _____ B _____
Homologation valid as from _____ in group

Hersteller: Dr. Ing. h. c. F. Porsche AG Modell und Typ: 911 Turbo
Manufacturer Model and type

Seite od. Nachtrag Page or ext.	Artikel Art.	Beschreibung Description		
S. 7	701a	Verstärkte Vorderachslenker Reinforced front wishbone	Foto Photo	1 1
S. 5	401	Kunststofftank 110 Liter Plastic fuel tank 110 Litre	Foto Photo	2 2
S. 5	401	Sicherheitstank 100/120 Liter FISA FT3 Safety fuel tank 100/120 Litre Specific.	Foto Photo	3 3
S. 8	803	Verbesserte Bremsanlage vorn u. hinten mit 2 Hauptbremszylindern u. Waagebalken- ausgleich	Fotos	4+5
S. 8	803	Improved brake system front and rear with 2 main brake cylinders and balance	Photos	4+5
S. 7	701	Aus- und Einfederungsanschlänge an Vorder- und Hinterachse	Fotos	6+7
S. 7	701	Rebound and compression stop on front and rear axle	Photos	6+7
S. 8	803	Hydraulische Handbremse Hydraulic handbrake	Foto Photo	8 8
S. 8	803	Hydraulische Bremskraftverstellung Hydraulic brake regulator	Foto Photo	9 9

Marke Porsche
MakeModell 911 Turbo
ModelHomologations Nr. _____
Homologation No: _____Nachtrag Nr. _____
Ext. No: _____

02 / 01 VO

Seite od. Nachtrag Page or ext	Artikel Art.	Beschreibung Description		
S. 7	701	Verstärkte Stabilisatoren vorn und hinten	Fotos	12+13
S. 7	701	Reinforced stabilizers front and rear	Photos	12+13
S. 6	603	Getriebeölpumpe Gearbox oil pump	Foto Photo	14 14
S. 5	333	Öltank der Trockensumpfschmierung im Kofferraum	Foto	15
S. 5	333	Oil tank of dry sump lubrication in trunk	Photo	15
S. 7	701	Verstärkte Radnaben mit Zentralverschluß und Bremsenkühlung vorn und hinten	Fotos	16+17
S. 7	701	Reinforced wheel carriers with central locking and brake cooling front and rear	Photos	16+17
S. 7	606	Verstärkte Achswellen Reinforced drive shafts	Foto Photo	18 18
S. 7	701	Verstärkte Hinterachslenker Reinforced rear trailing arms	Foto Photo	19 19



Marke Porsche
Make

Modell 911 Turbo
Model

Homologations Nr. B-208
Homologation Nr.

Fotos
Photos

Nachtrag Nr. 02/010
Ext. Nr.

Foto 1



Foto 2



Foto 3

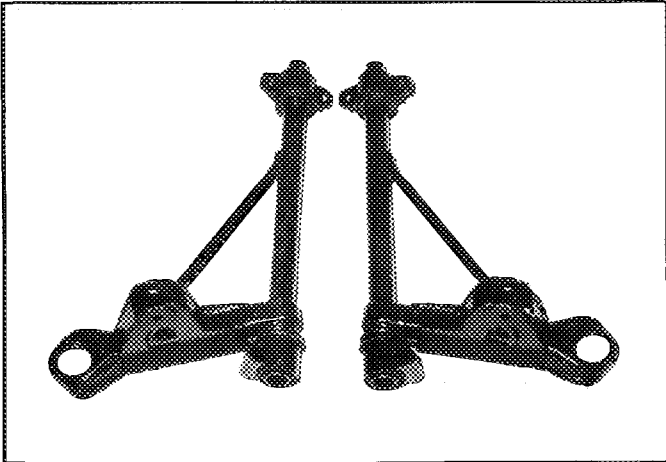

Foto 4

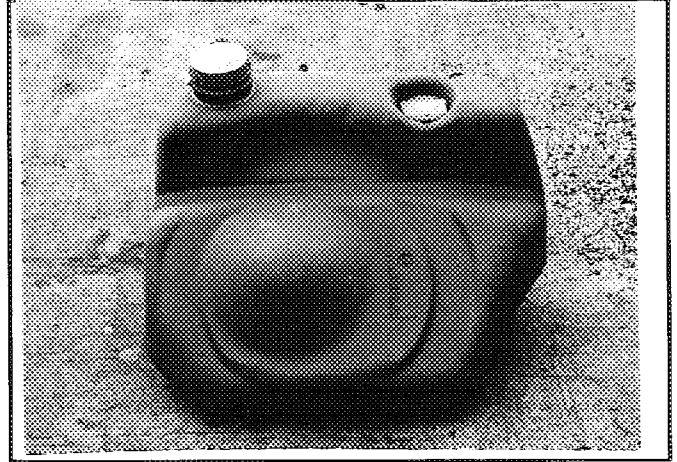

Foto 5

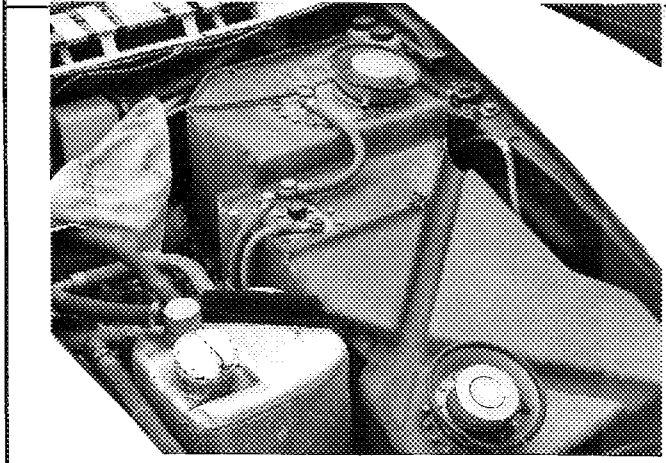

Foto 6

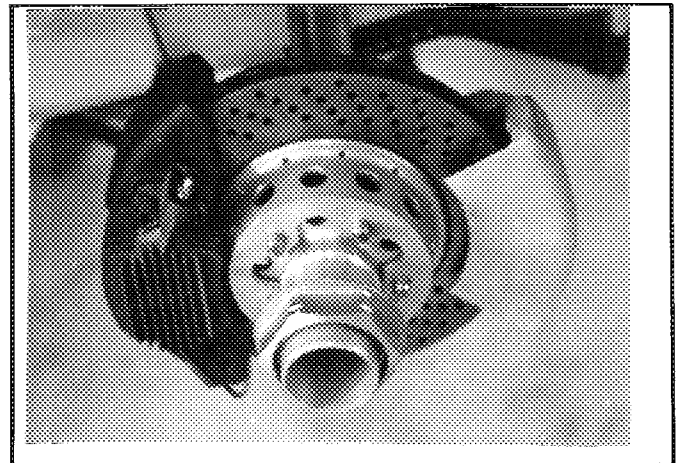

Marke Porsche
Make

Modell 911 Turbo
Model

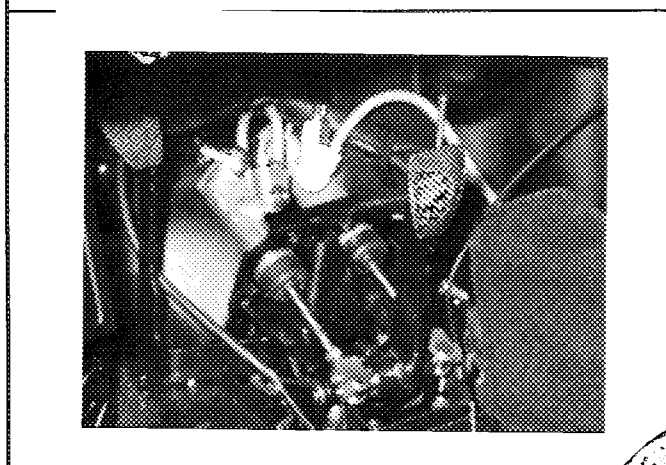
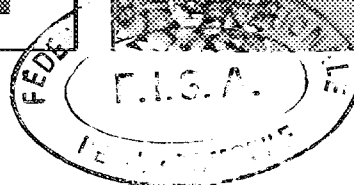
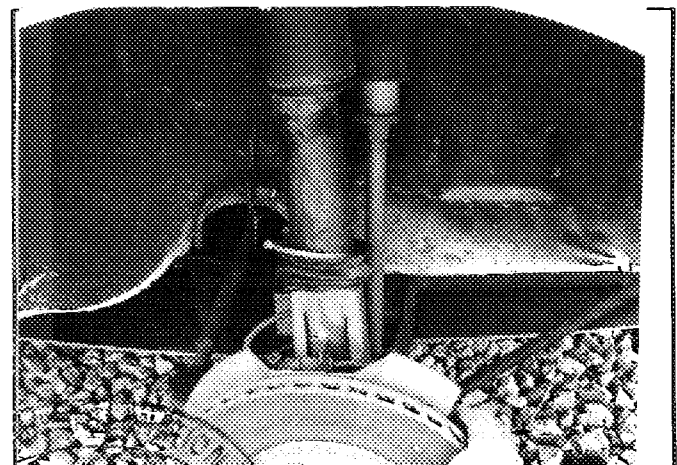
Homologations Nr. B-208
Homologation Nr

Fotos
Photos

Nachtrag Nr. 02/01V0
Ext. Nr

Foto 7



Foto 8



Foto 9

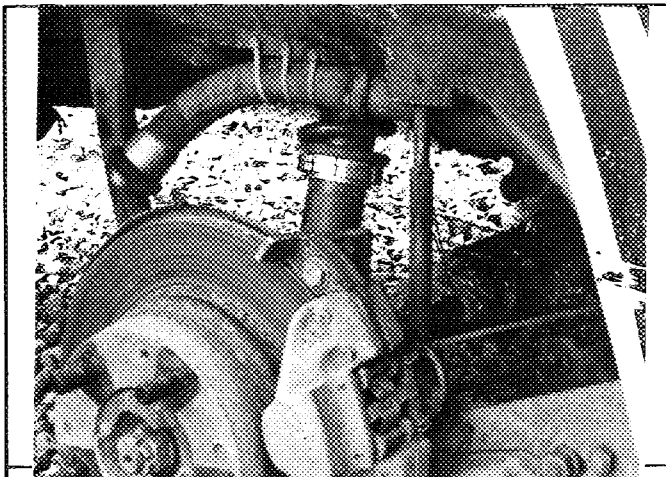

Foto 12

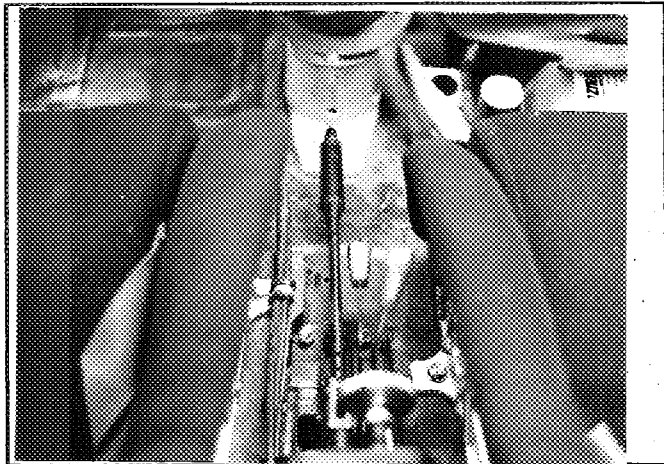

Fotos
Photos

Nachtrag Nr. 02/04/00
Ext. Nr.

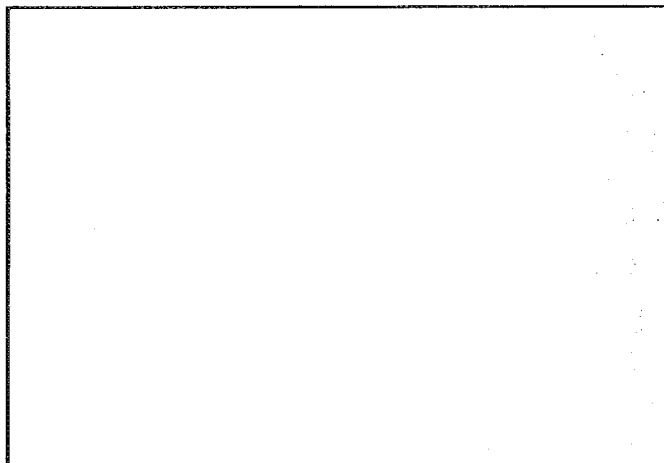
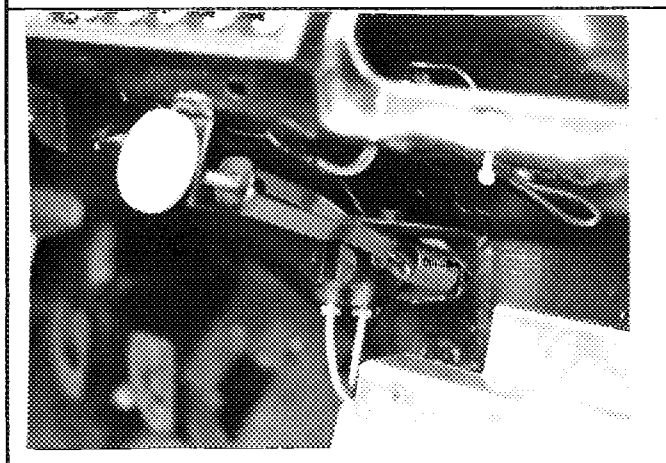
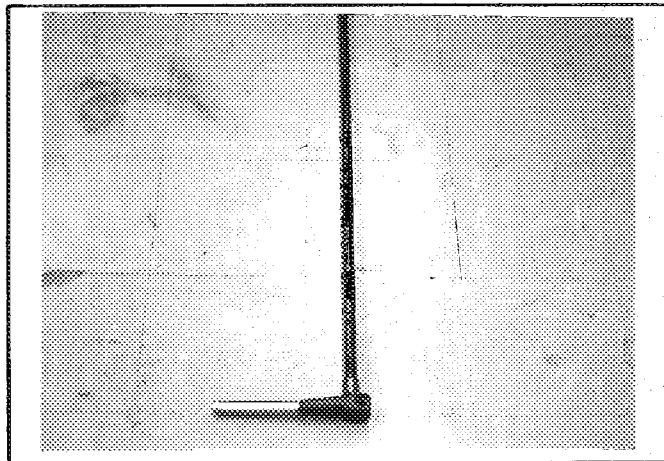
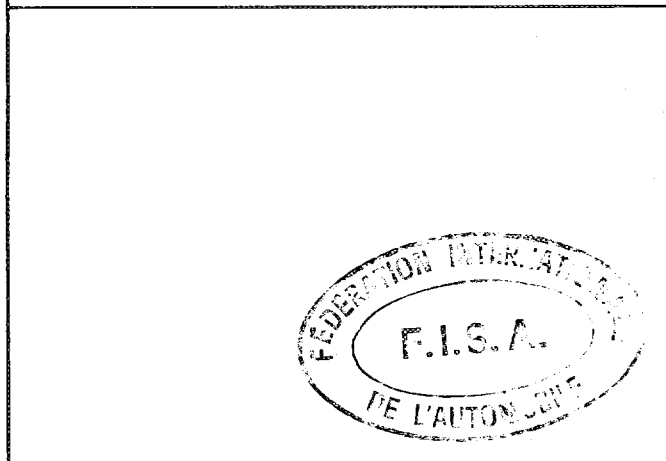
Foto 13



Foto 14



Foto 15

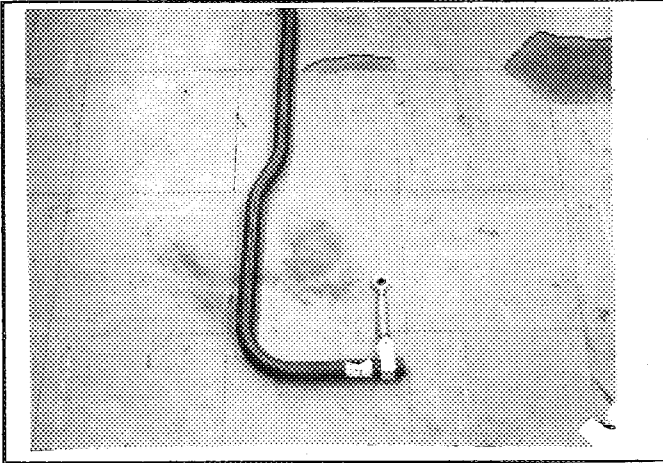

Foto 16

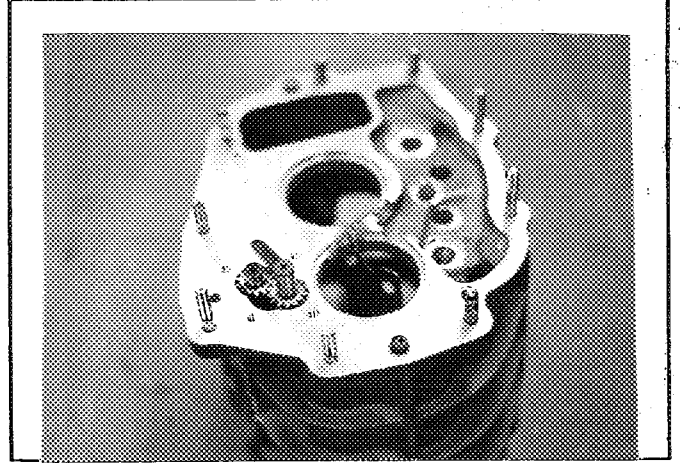

Foto 17

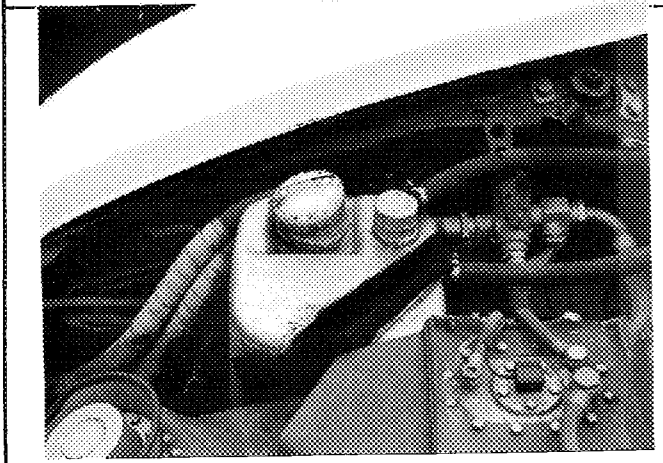

Foto 18

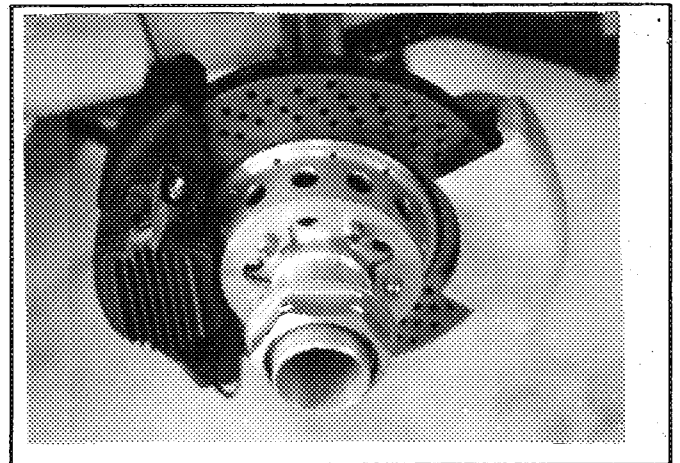

Marke Porsche
Make

Modell 911 Turbo
Model

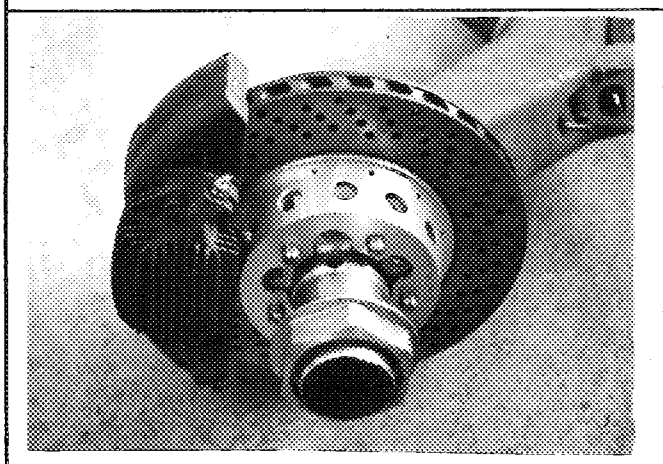
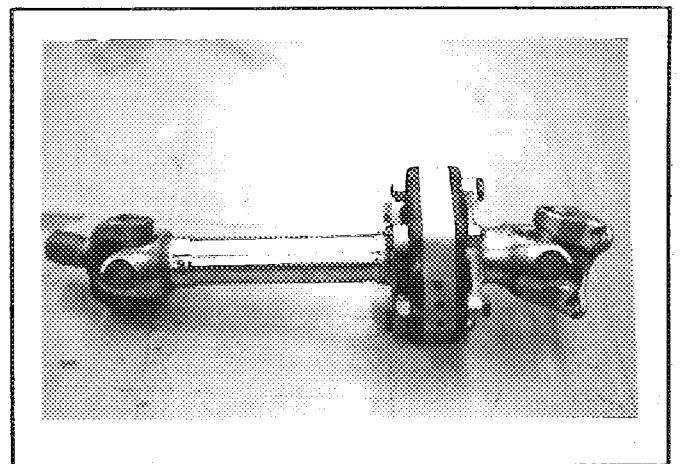
Homologations Nr. B-208
Homologation Nr.

Fotos
Photos

Nachtrag Nr. 02 / 01 fvo
Ext. Nr.

Foto 19

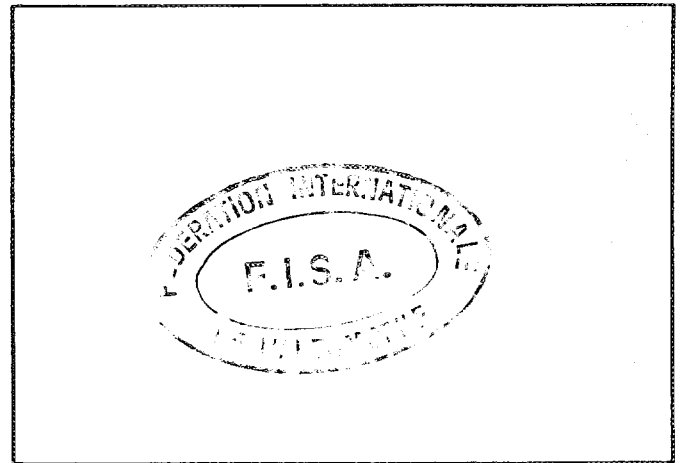
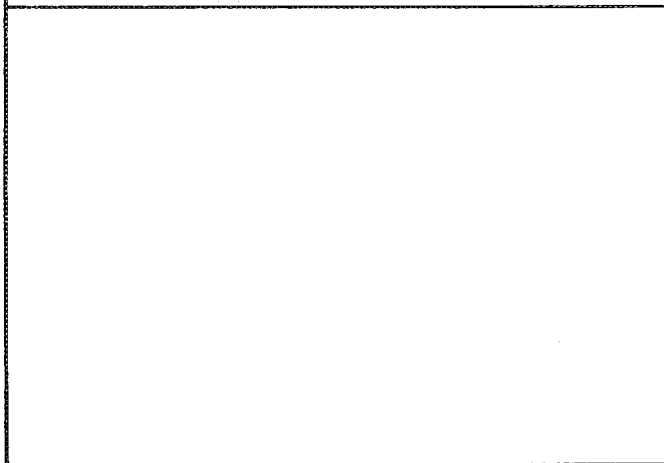
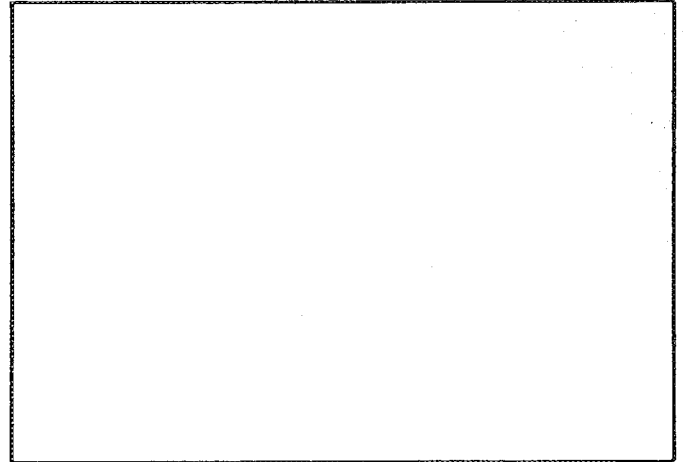
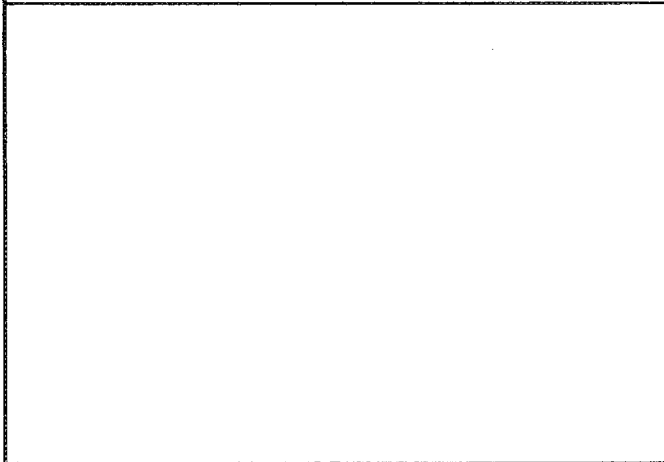
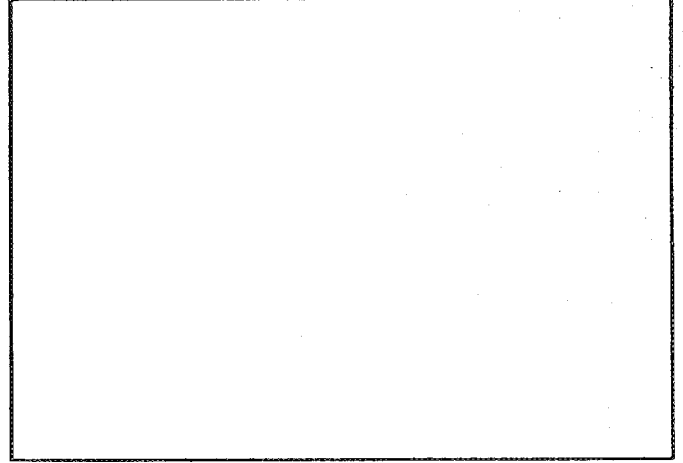
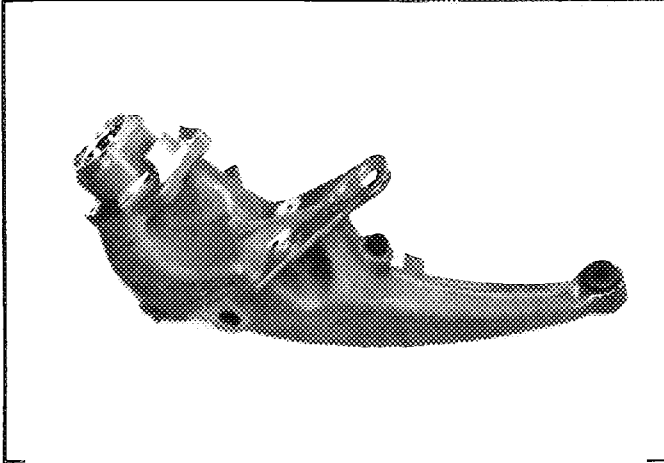

B-208

Marke Porsche
Make

Modell 911 Turbo
Model

Homologations Nr. _____
Homologation Nr.

Fotos
Photos

Nachtrag Nr. 04 / 03 VO
Ext. Nr.

Foto 1, Photo 1



Foto 2, Photo 2



Foto 3, Photo 3

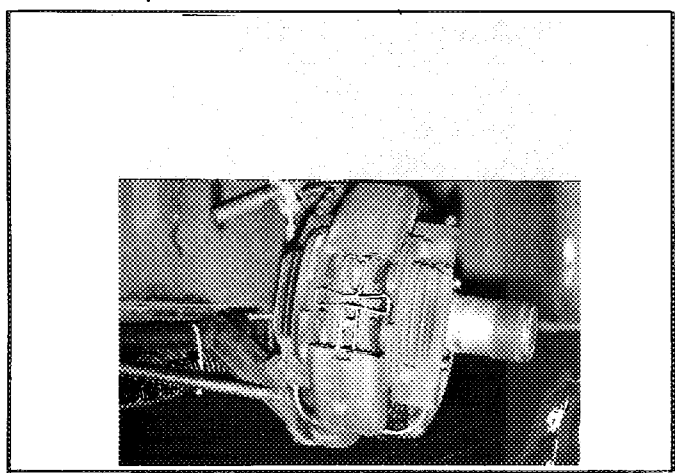

Foto 4, Photo 4



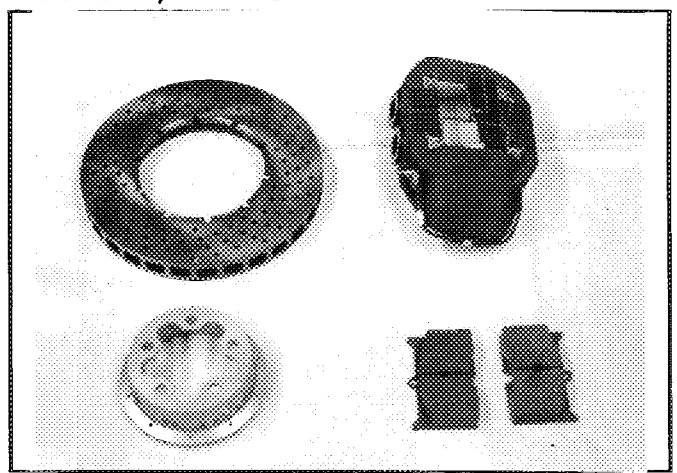

FEDERATION INTERNATIONALE DU SPORT AUTOMOBILE

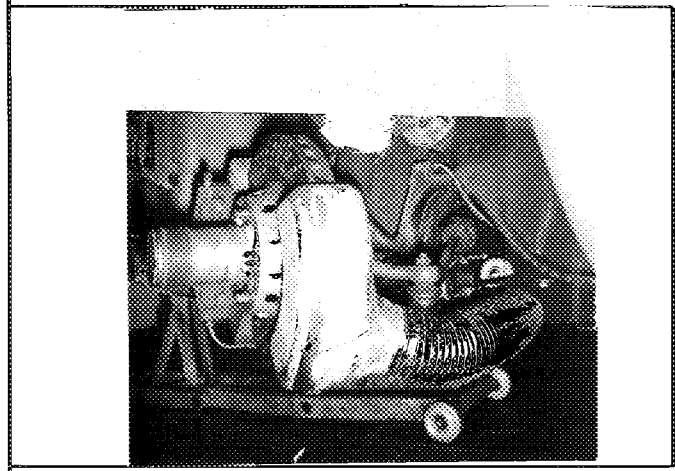
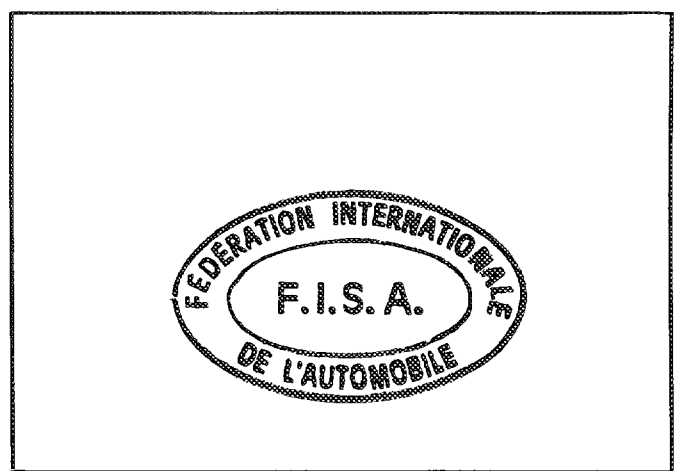
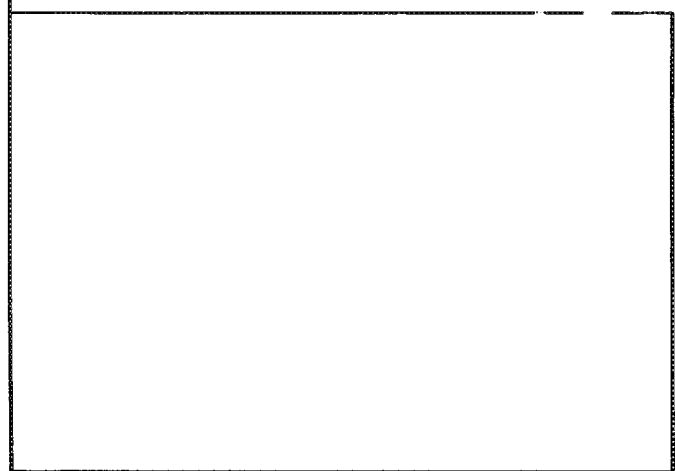
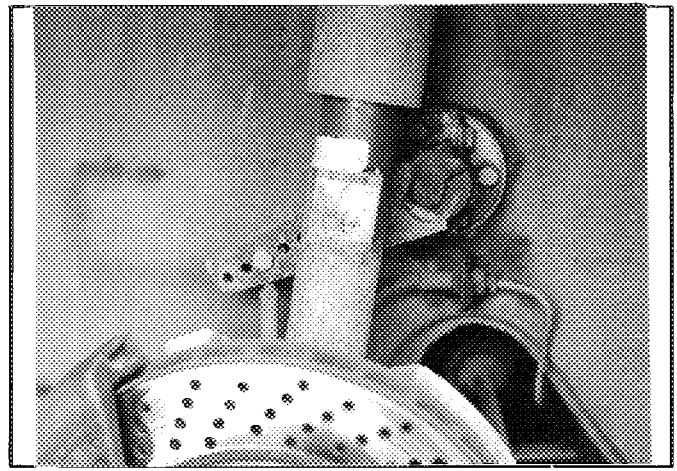
Homologation N°

B - 208

Extension N°

05 / 01 ER

FICHE D'EXTENSION A L'HOMOLOGATION OFFICIELLE FISA
FORM OF EXTENSION TO THE OFFICIAL FISA HOMOLOGATION

- ET** Evolution normale du type: dès le numéro de châssis
Normal evolution of the type: as from chassis number _____
- VF** Variante de fourniture / Supply variant
- VO** Variante option / Option variant
- ER** Errata / Erratum

Homologation valable dès le - 1 AOUT 1983 en groupe B
Homologation valid as from _____ in group _____

Constructeur Dr.-Ing. h.c.F. Porsche AG Modèle et type Porsche 911 Turbo
Manufacturer _____ Model and type _____

Page ou ext. Page or ext.	Art. Art.	Description Description
S. 16	603e	<p style="text-align: center;"><u>Ref. 01/01 ET</u></p> <p>übersetzungen: 4. Gang nun 32/20 anstatt 32/22 Ratios: 4th speed now 32/20 instead of 32/22</p>





FEDERATION INTERNATIONALE DU SPORT AUTOMOBILE

Homologation N°

B - 208

Extension N°

06 / 02 ER

FICHE D'EXTENSION A L'HOMOLOGATION OFFICIELLE FISA
FORM OF EXTENSION TO THE OFFICIAL FISA HOMOLOGATION

ET Evolution normale du type: dès le numéro de châssis
Normal evolution of the type: as from chassis number _____

VF Variante de fourniture / Supply variant

VO Variante option / Option variant

ER Errata / Erratum

Homologation valable dès le **- 1 SEP. 1984** en groupe **B**
Homologation valid as from _____ in group _____

Constructeur **Porsche** Modèle et type **911 turbo**
Manufacturer _____ Model and type _____

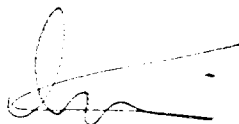
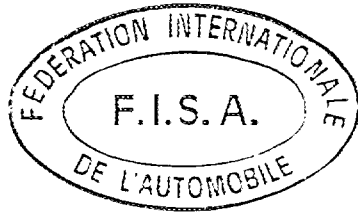
Page ou ext. Page or ext.	Art. Art.	Description Description
12	photo J	Ø de la sortie du collecteur d'échappement :
12	photo J	Ø of the exhaust manifold exit. :
		<u>61,0 et 58,5 mm</u>
		 



FEDERATION INTERNATIONALE DU SPORT AUTOMOBILE

Homologation N°

B 208

07 / 03 ER

Groupe **A/B**
Group

FICHE D'HOMOLOGATION ADDITIONNELLE POUR MOTEURS SURALIMENTÉS PAR TURBOCOMPRESSEUR(S) ADDITIONAL HOMOLOGATION FORM FOR TURBO CHARGED ENGINES

Véhicule : Constructeur Dr.-Ing.h.c.F. Porsche AG Modèle et type 911 Turbo: 2993cc - 3299cc.
Vehicle : Manufacturer Dr.-Ing.h.c.F. Porsche AG Model and type 911 Turbo: 2993cc - 3299cc.

Homologation valable à partir du - 1 DEC. 1984 en groupe B
Homologation valid as from - 1 DEC. 1984 in group B

334. Suralimentation
Turbocharging

a) Marque et type du turbo compresseur KKK 3LDZ
Make and type of the turbocharger KKK 3LDZ

b) Carter de turbine :
Turbine housing :

b1) Nombre d'entrées des gaz d'échappement 1
Number of exhaust gas entries 1

b2) Matériau Cr-Ni-Si-Al-Legierung
Material Cr-Ni-Si-Al-Legierung

c) Roue de turbine :
Turbine wheel :

c1) Matériau Nickel-Legierung
Material Nickel-Legierung

c2) Nombre d'aubes 12
Number of blades 12

c3) Hauteur(s) d'une aube 9,2 mm
Height(s) of blade 9,2 mm

c4) Préciser les cotes A,B,C, selon le schéma suivant :
Indicate the dimensions A, B, C, according the following sketch :

A = 61,3 mm
B = 9,2 mm
C = 75,7 mm

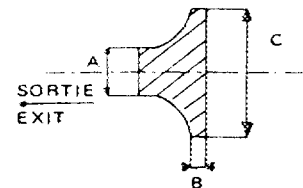

d) Carter de compression :
Impeller housing :

d1) Nombre d'entrée d'air (mélange) 1
Number of air entries (gas) 1

d2) Matériau Aluminium-Legierung
Material Aluminium-Legierung

e) Roue de compression
Impeller wheel :

e2) Nombre d'aubes 12
Number of blades 12

e3) Hauteur(s) d'une aube 7,6 mm
Height(s) of blade 7,6 mm

e4) Préciser les cotes A, B, C selon le schéma suivant :
Indicate the dimensions A, B, C, according to the following sketch,

A = 53,5 mm
B = 7,6 mm
C = 80,0 mm

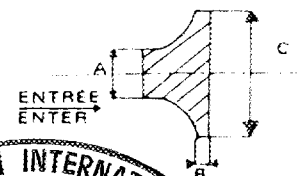

Marque / Make: Porsche Modèle / Model: 911 Turbo N° Homol.: B 208

07 / 03 ER

f) Régulation de la pression :
Pressure regulation :

f1) Type de régulation de la pression : by-pass soupape de décharge / relief valve autre cas / other case
Type of pressure adjustment :

f2) Préciser le type de la soupape et son contrôle
Indicate the type of the valve and its control: Abblaseventil pneumatisch / pneumatic waste-gate

g) Système d'échappement :
Exhaust system :

Dimensions intérieures de l'éventuel tuyau d'échappement entre le collecteur d'échappement et le turbocompresseur (dessin)
Internal dimensions of the eventual exhaust pipes between exhaust manifold and turbocharger (sketch)

h) Refroidissement de l'air d'admission : oui/~~non~~ / yes/~~no~~
Cooling of intake air :

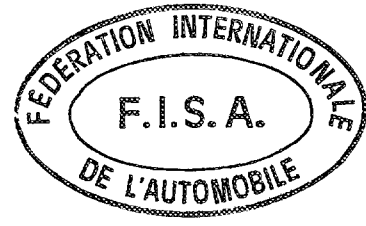

PHOTOS

k) Vue de dessus du turbo compresseur
Plan view of turbocharger

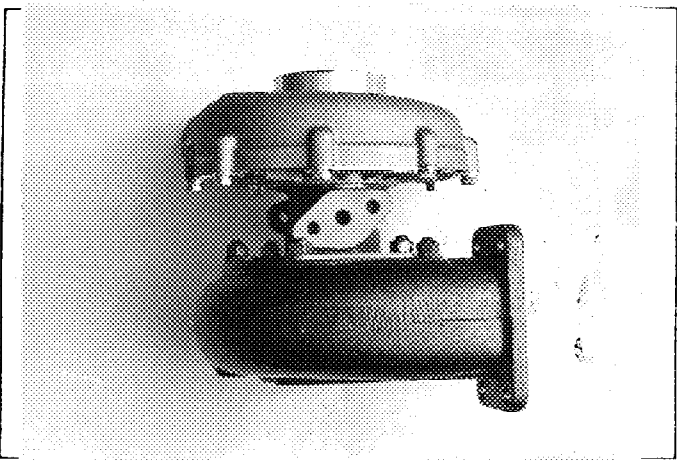

L) Vue de face du turbo compresseur
Front view of turbocharger

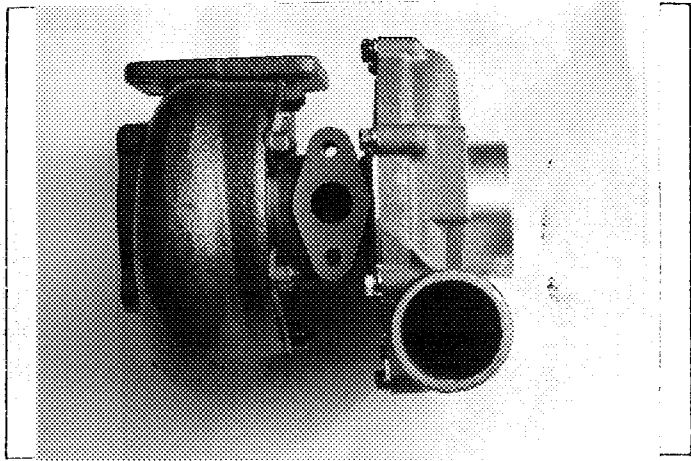

Marque
Make Porsche

Modèle
Model

911 Turbo

N° Homol. B 208

07 / 03 ER

M) Vue de côté du turbocompresseur
Side view of turbocharger

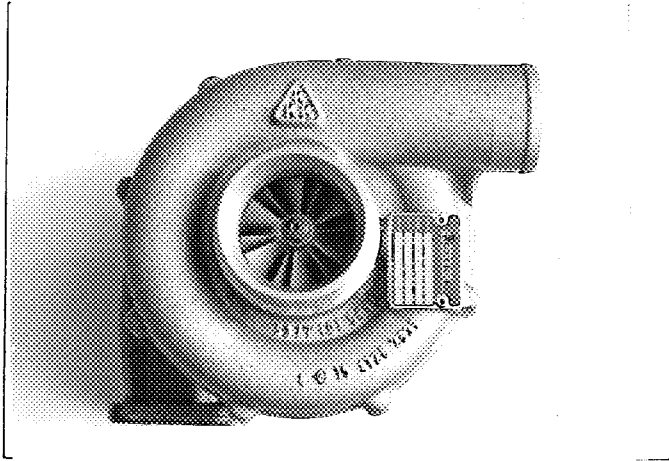

N) Carter de turbine du turbocompresseur
Turbine housing of turbocharger

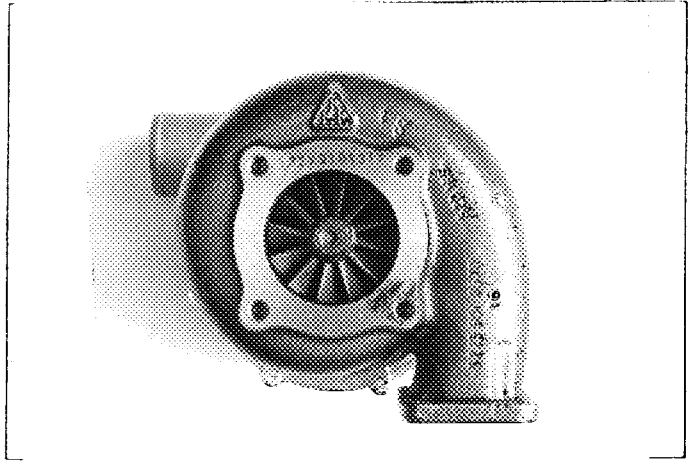

O) Soupape et montage du by-pass du turbocompresseur
Valve and by-pass installation of turbocharger

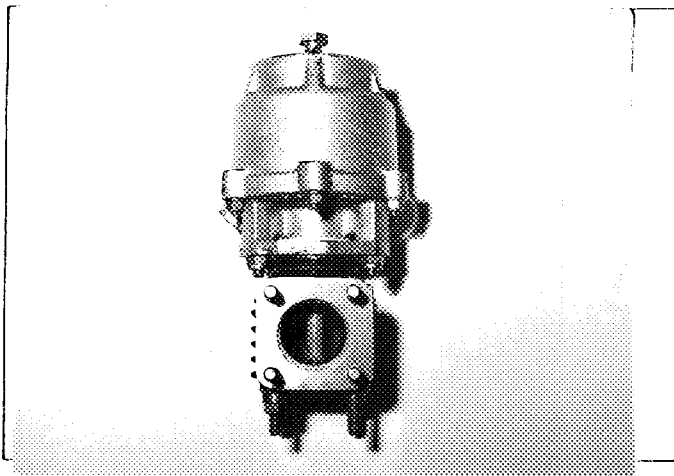

P) Eventuel échappement entre le collecteur d'échappement et le turbocompresseur.

Eventual exhaust pipes between the exhaust manifold and the turbocharger.

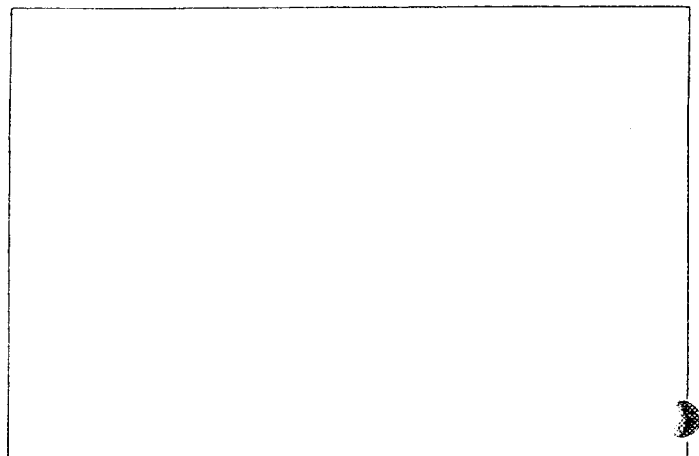

Q) Carter de compression du turbocompresseur
Impeller housing of turbocharger

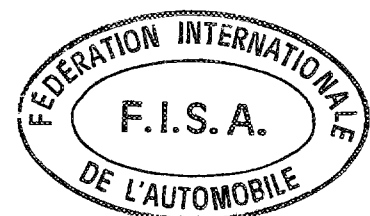
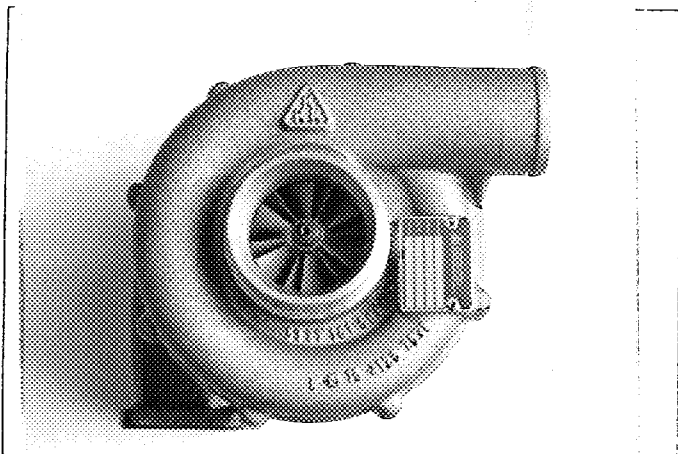

Marque
Make

Porsche

Modèle
Model

911 Turbo

N° Homol. B 208

07/03 ER

DESSINS / DRAWINGS

V) Entrée des gaz d'échappement dans le carter de turbine du turbocompresseur
Exhaust gas entry in the turbine housing of turbocharger.

VI) Sortie des gaz d'échappement du carter de turbine de turbocompresseur.
Exhaust gas exit of the turbine housing of turbocharger.

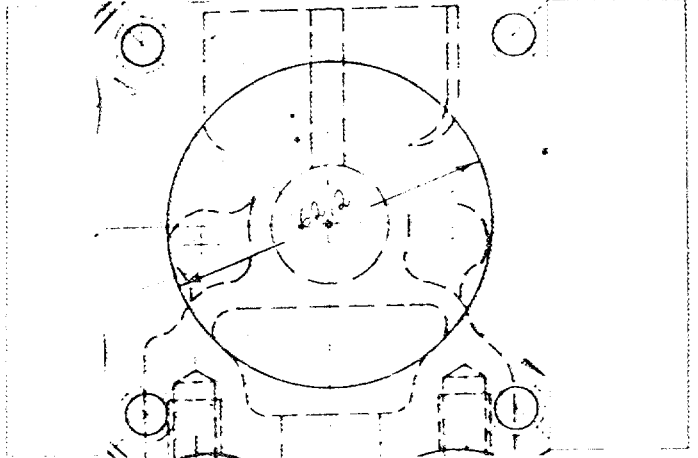
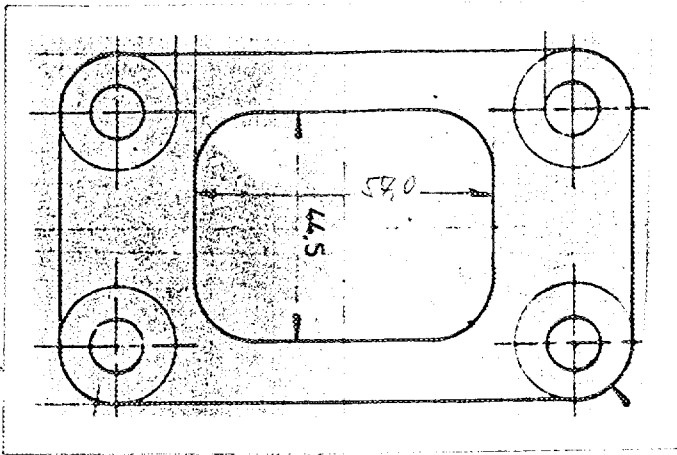

VII) Entrée de l'air (mélange) dans le carter de compression du turbocompresseur.
Air (gas) entry in the impeller housing of the turbocharger.

VIII) Sortie de l'air (mélange) du carter de compression du turbocompresseur.
Air (gas) exit of the impeller housing of the turbocharger.

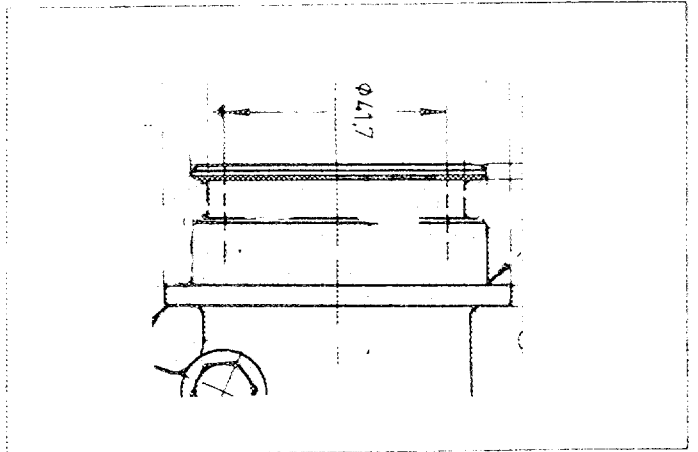
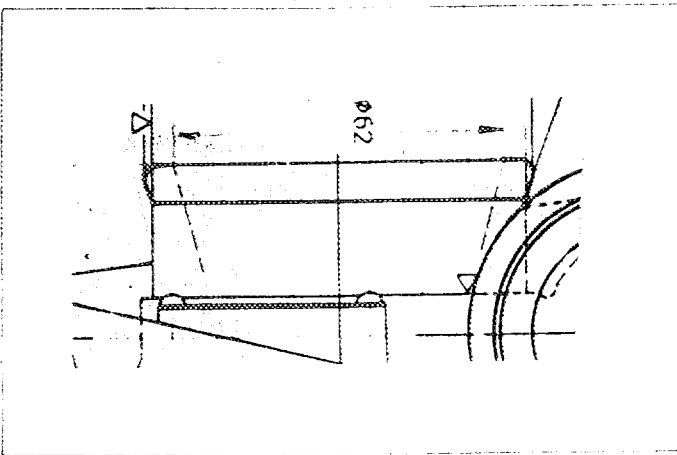

IX. Dispositif réglant la pression de suralimentation
Device regulating the turbocharging pressure.

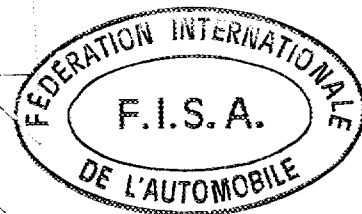
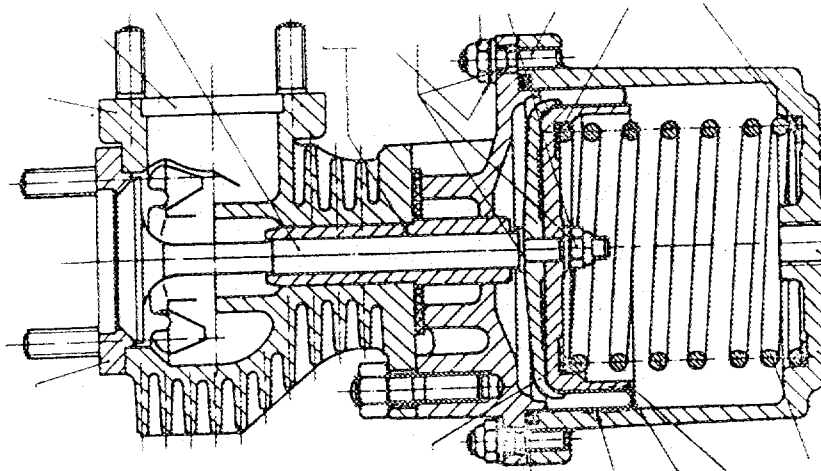



FEDERATION INTERNATIONALE DU SPORT AUTOMOBILE

Homologation N°

B - 208

Extension N°

08 / 04 ER

FICHE D'EXTENSION A L'HOMOLOGATION OFFICIELLE FISA
FORM OF EXTENSION TO THE OFFICIAL FISA HOMOLOGATION

- ES** Evolution sportive du type / Sporting evolution of the type
- ET** Evolution normale du type / Normal evolution of the type
- VF** Variante de fourniture / Supply variant
- VO** Variante option / Option variant
- ER** Errata / Erratum

Homologation valable dès le 01 JAN. 1985 en groupe B
Homologation valid as from _____ in group _____

Constructeur Dr. Ing.h.c.f. Porsche AG Modèle et type 911 Turbo
Manufacturer _____ Model and type _____

Page ou ext. Page or ext.	Art. Art.	Description Description
		03 / 02 V0

ARCEAU

limite élastique lire: 34.5 au lieu de: 345

résistance à la traction lire: 39.0 au lieu de: 390

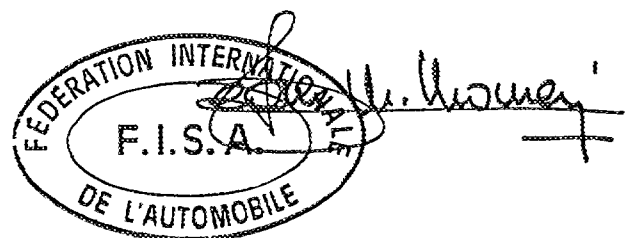

FÉDÉRATION INTERNATIONALE DU SPORT AUTOMOBILE
 D.S. Oberste Nationale Sportkommission für den Automobilsport in Deutschland GmbH

Homologation Nr.

B - 208

Nachtrag Nr.
 Extension Nr.

09 - 05 ER

Nachtrag zum offiziellen Testblatt der FISA
 Form of extension to the official FISA-Homologation

ER Berichtigung
 Erratum 01 - 01 ET

AVR. 1986

Homologation gültig ab: _____ in Gruppe: B
 Homologation valid as from: _____ in group

Hersteller: Dr.-Ing.h.c.F. Porsche AG Modell und Typ: 911 Turbo
 Manufacturer: _____ Model and type

Cooling of air intake
 Refroidissement de l'air de admission

yes/~~no~~
 oui/~~non~~

System
 Système

air/air

[Handwritten signature]

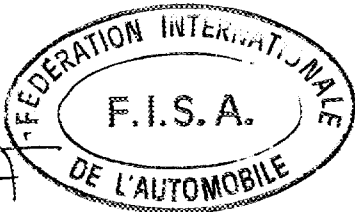

~~water/air~~
~~eau/air~~

simplex/~~duplex~~

Cooling of the turbo by water
 Refroidissement de turbo avec eau

~~yes~~/no
~~oui~~/non

Water injection
 Injection d'eau

~~yes~~/no
~~oui~~/non

Air inlet diameter
 Diamètre de l'entrée de air

Ø 60 mm

Air outlet diameter
 Diamètre de sortie d'air

Ø 60 mm

Photo of mounted device
 Photo du dispositif monté

Photo unmounted
 Photo démonté

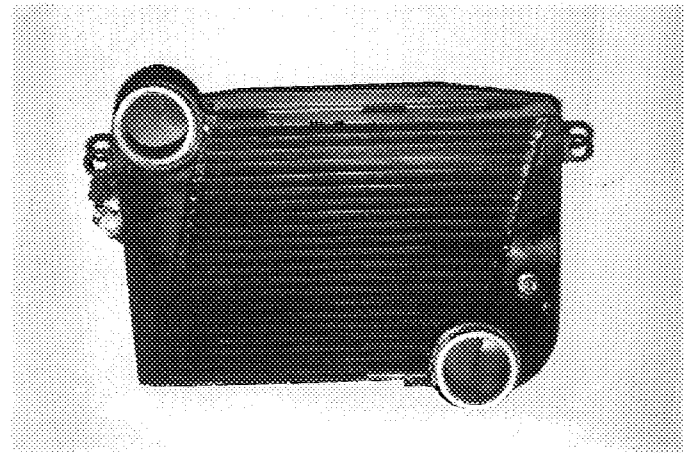
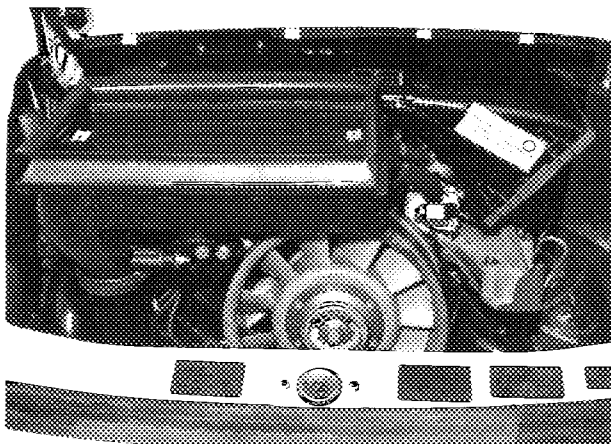



FEDERATION INTERNATIONALE DU SPORT AUTOMOBILE

Homologation N°

B - 208

Extension N°

10 / 06 ER

FICHE D'EXTENSION A L'HOMOLOGATION OFFICIELLE FISA
FORM OF EXTENSION TO THE OFFICIAL FISA HOMOLOGATION

- ES** Evolution sportive du type / Sporting evolution of the type
- ET** Evolution normale du type / Normal evolution of the type
- VF** Variante de fourniture / Supply variant
- VO** Variante option / Option variant
- ER** Errata / Erratum

Homologation valable dès le _____ en groupe _____
Homologation valid as from 1er Janvier 1988 in group B

Constructeur PORSCHE Modèle et type 911 Turbo
Manufacturer PORSCHE Model and type 911 Turbo

Page ou ext. Page or ext.	Art. Art.	Description Description
		<p>Suite au changement du coefficient de suralimentation porté de (1.4) à (1.7) à partir du 1er Janvier 1988 :</p> <p><u>Articles 103 et 307b</u> : 2993 x 1.7 = 5088.1</p> <p><u>Article 307c</u> : 3032 x 1.7 = 5154.4</p> <p>Pour l'extension 01/01 ET :</p> <p><u>Articles 103 et 307b</u> : 3299 x 1.7 = 5608.3</p> <p><u>Article 307c</u> : 3339 x 1.7 = 5676.3</p>

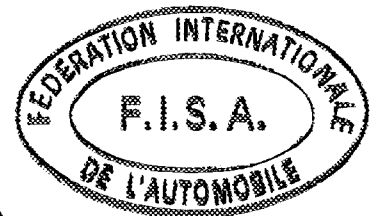

[Handwritten signature]



FEDERATION INTERNATIONALE DE L'AUTOMOBILE

PORSCHE - 911 TURBO

3/82

B 208

MARQUE ET MODELE

VALIDITE HOMOLOGATION

FICHE NR.

B / 4500

GROUPE / CLASSE

EXTENSIONS	DEBUT VALIDITE	DESCRIPTION	NOTES
01/01ET	3/82	MOTEUR 3299cc - RAPPOR TS - FREINS -	classe 5000 cc.
02/01VO	3/82	SUSPENSION - RESERVOIR - FREINS BARRE ANTIROULIS - POMPE A HUILE BOITE A VITESSES - RESERVOIR D'HUILE - MOYEN - TRANSMISSION	
03/02VO	3/82	ARCEAU ALL	
04/03VO	7/83	FREIN - BARRE ANTIROULIS	
05/01ER	8/83	RAPPORT	
06/02ER	9/83	COLLECTEUR D'ECHAPPEMENT	
07/03ER	12/84	TURBOCOMPRESSEUR	
08/04ER	1/85	ARCEAU -	
09/05ER	4/86	INTERCOOLER -	
10/06ER	1/88	CHANGEMENT DE COEFFICIENT	CLASSE 5500cc

Autres homologations du modèle

3076
3076 TRANSFERT B

Vérifiée le 24/08/88 par [Signature] visée ce jour le _____ par _____