

COMMISSION SPORTIVE  
01526 22.1173  
INTERNATIONALE



F.I.A. Recognition No. 5565  
Group 1

## ROYAL AUTOMOBILE CLUB

31 Belgrave Square, London, SW1X 8QH

Form of recognition in accordance with appendix J to the International Sporting Code of the  
FEDERATION INTERNATIONALE DE L'AUTOMOBILE

Cylinder-capacity 2279 cm.<sup>3</sup> 139 in.<sup>3</sup>  
Manufacturer Vauxhall Motors Limited Model Firenza - Magnum 2300  
Serial No. of chassis/body 90000 onwards Manufacturer Vauxhall Motors  
Serial No. of engine 3000000 Manufacturer Vauxhall Motors  
Recognition is valid from 1 h 7h List  
The manufacturing of the model described in this recognition form started on April 1972  
and the minimum production of 5000 identical cars, in accordance with the specifications of  
this form was reached on March 1973

Photograph A. ¼ view of car from front



F.I.A. Stamp

R.A.C. Stamp

5565

B



C



D

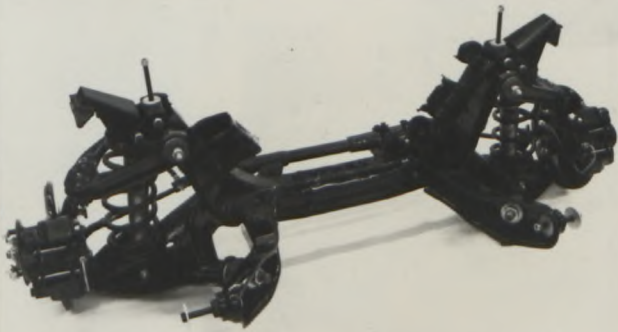

E

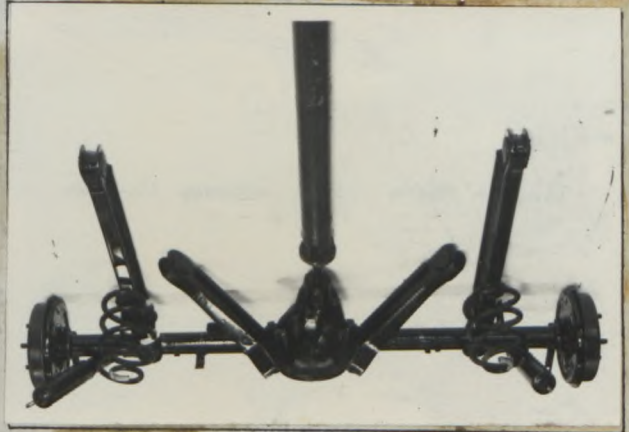

F

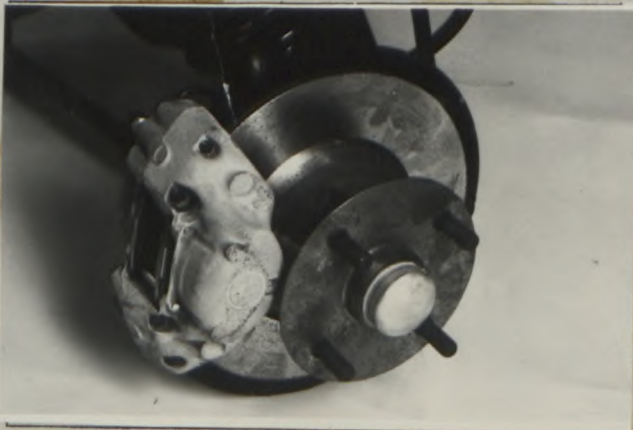

G



H

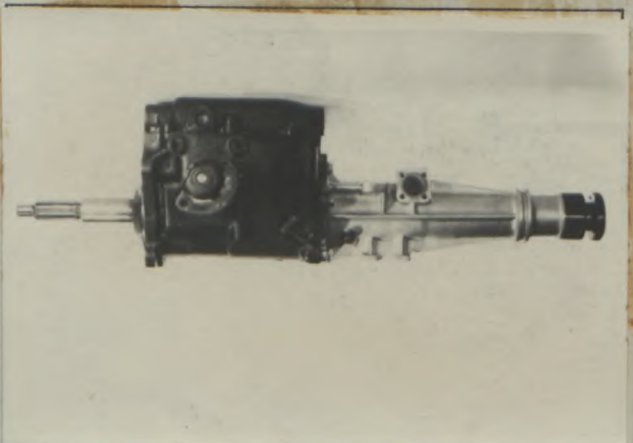

I

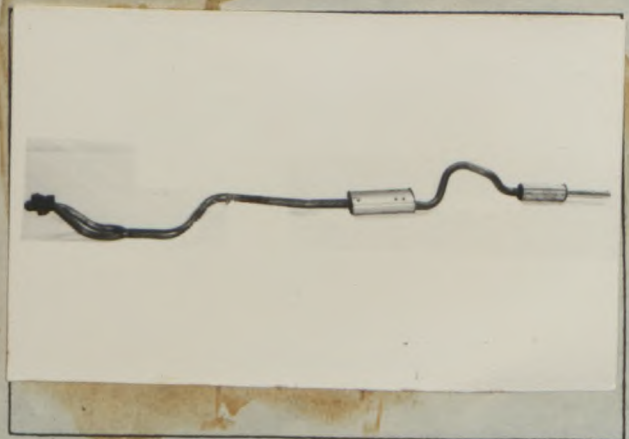

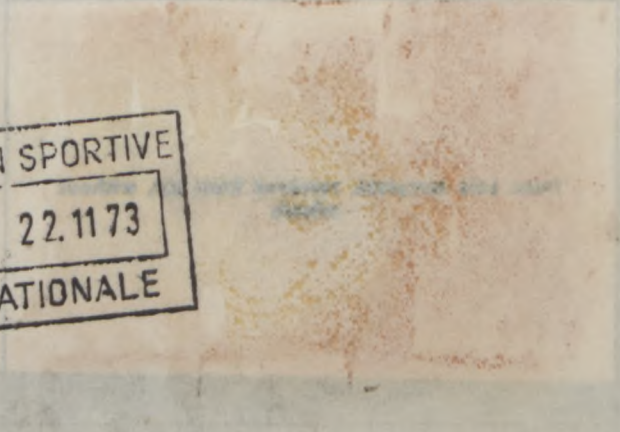

COMMISSION SPORTIVE  
 01526 22.1173  
 INTERNATIONALE

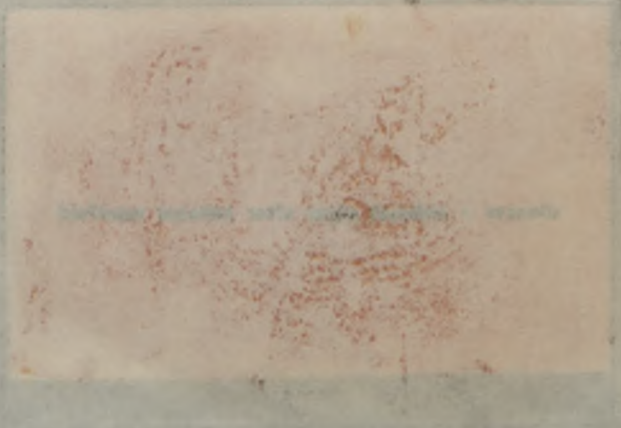

5565

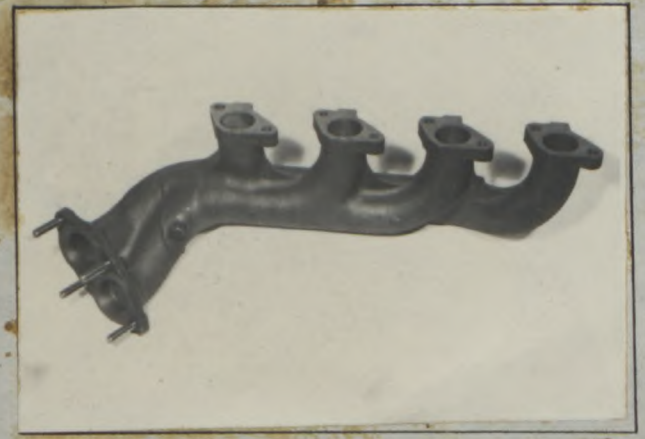
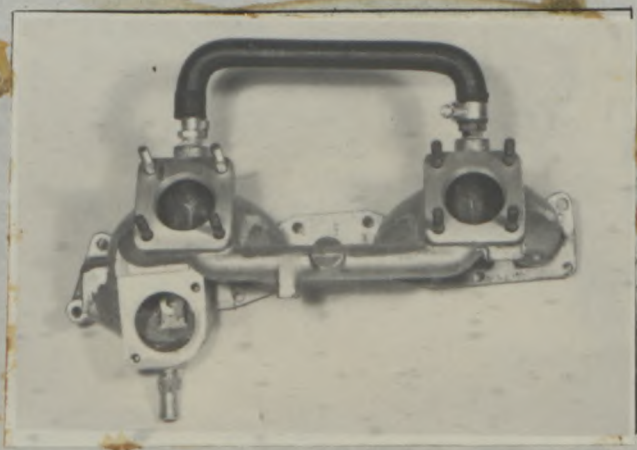
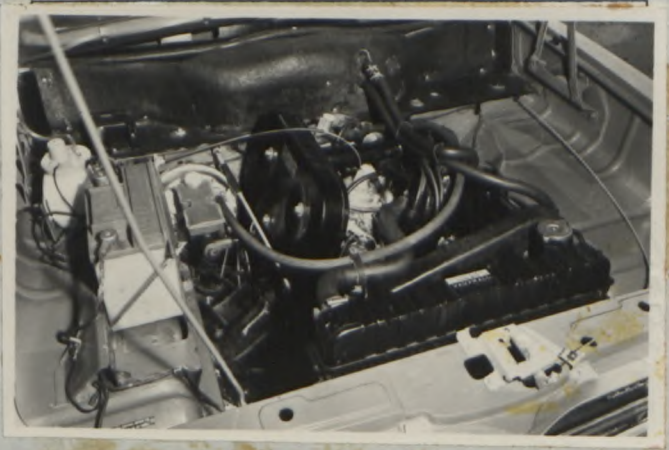
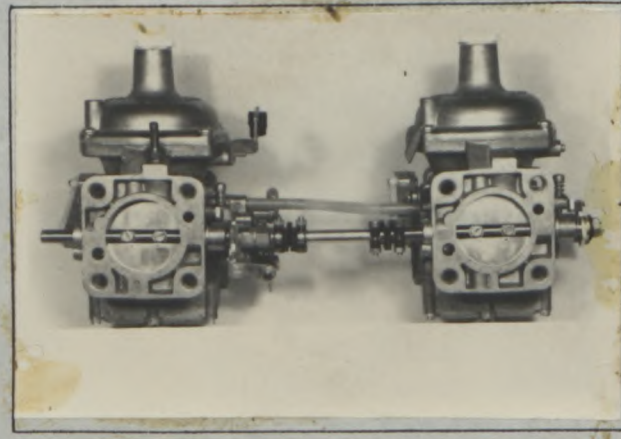
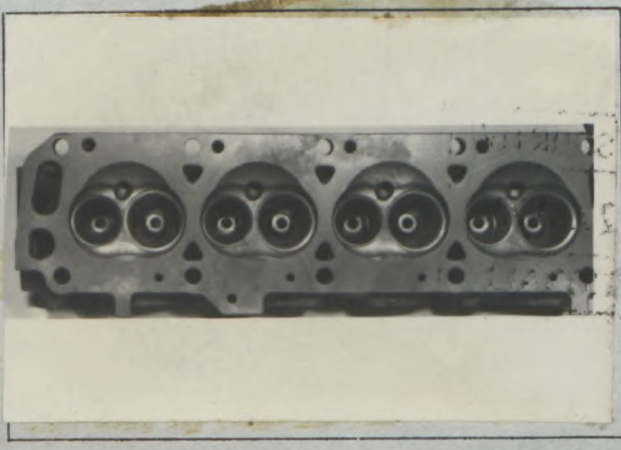
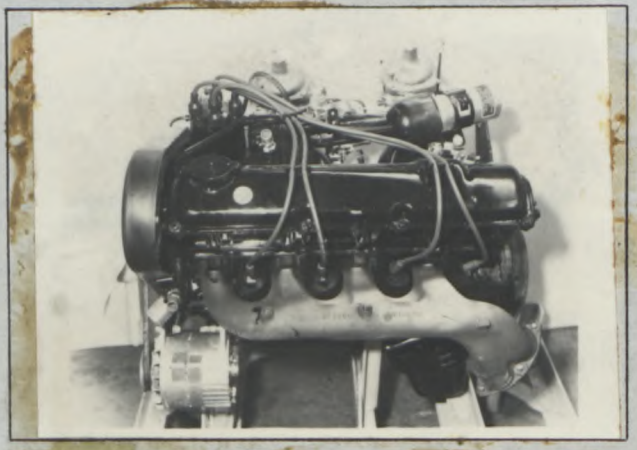
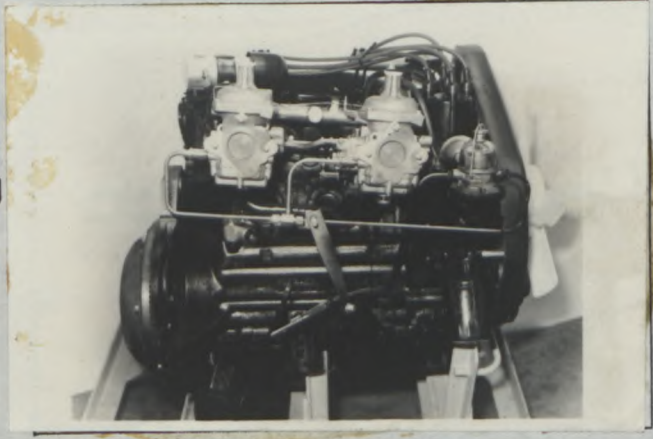

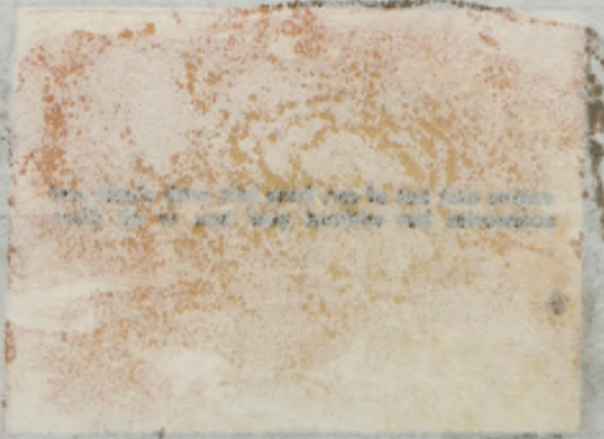

COMMISSION SPORTIVE  
 01526 22.1173  
 INTERNATIONALE

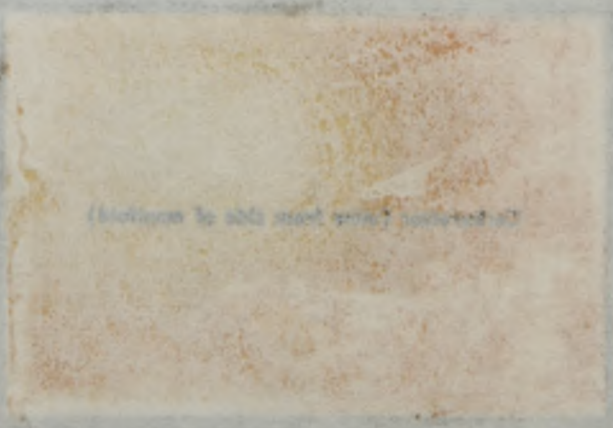

Make Vauxhall

Model Firenza - Magnum

F.I.A. Rec. No. 5565

Drawing inlet manifold ports, side of cylinderhead. Indicate scale or dimensions and manufacturing tolerance.

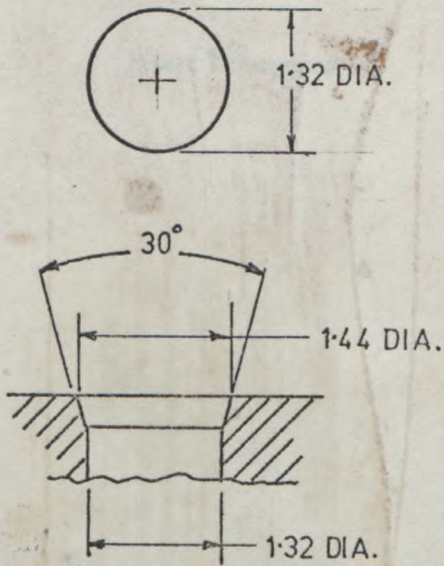

Drawing of entrance to inlet port of cylinderhead. Indicate scale or dimensions and manufacturing tolerance.

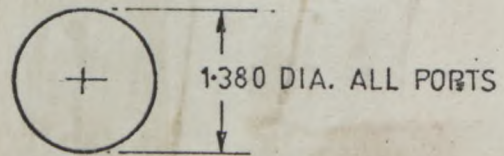

Drawing of exhaust manifold ports, side of cylinderhead. Indicate scale or dimensions and manufacturing tolerance.

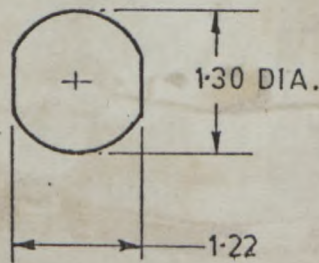

Drawing of exit to exhaust port of cylinderhead. Indicate scale or dimensions and manufacturing tolerance.

NOTE: Code 052. Exhaust Emission.  
Port and manifold areas fully fettled to 2% tolerance.

Tolerances :  $\pm .030$  inches  $.76$  mm



COMMISSION SPORTIVE  
01526 22.1173  
INTERNATIONALE





COMMISSION SPORTIVE  
01526 22.1173  
INTERNATIONALE

**CHASSIS AND COACHWORK (Photographs A, B and C)**

- |  |                             |
|--|-----------------------------|
| 20. Chassis/body construction: separate/unitary construction | Steel                       |
| 21. Unitary construction, material(s)                        | -                           |
| 22. Separate construction, Material(s) of chassis            | Steel                       |
| 23. Material(s) of coachwork                                 | Steel                       |
| 24. Number of doors      Material(s)                         | Steel                       |
| 25. Material(s) of bonnet                                    | Steel                       |
| 26. Material(s) of boot lid                                  | Steel                       |
| 27. Material(s) of rear-window                               | Laminate or toughened glass |
| 28. Material(s) of windscreen                                | Laminated Available         |
| 29. Material(s) of front-door windows                        | Laminate or toughened glass |
| 30. Material(s) of rear-door windows                         | -                           |
| 31. Sliding system of door windows                           | Gear operated drop glass    |
| 32. Material(s) of rear-quarter light                        | Laminate or toughened glass |

**ACCESSORIES AND UPHOLSTERY**

- |   |  |
|---|--|
| 38. Interior heating : yes — <del>no</del>                                      | 39. Air conditioning : <del>yes</del> — no   |
| 40. Ventilation : yes — <del>no</del>   | 41. Front seats, type of seat and upholstery |
| 42. Weight of front seat(s), complete with supports and rails, out of the car : | Tubular frame<br>blown P.V.C.                |
|   | 14 kg.      31 lbs.                          |
| 43. Rear seats, type of seat and upholstery                                     |  |
| 44. Front bumper, material(s)    Steel    Weight                                | 3.6 kg.      8 lbs.                          |
| 45. Rear bumper, material(s)    Steel    Weight                                 | 3.1 kg.      7 lbs.                          |

**WHEELS**

- |  |  |
|--|--|
| 50. Type      Disc                         |  |
| 51. Weight (per wheel, without tyre)       | 6.8 kg.      15 lbs.                   |
| 52. Method of attachment      4 stud       |  |
| 53. Rim diameter      330 mm.      13 ins. | 54. Rim width      127 mm.      5 ins. |

**STEERING**

- |  |
|--|
| 60. Type      Rack and Pinion                                  |
| 61. Servo-assistance : <del>yes</del> — no                     |
| 62. Number of turns of steering wheel from lock to lock    3.1 |
| 63. In case of servo-assistance                                |

COMMISSION SPORTIVE  
01526 22.11.73  
INTERNATIONALE

Make Vauxhall Motors

Model Firenza Magnum

F.I.A. Rec. No. 5565

### SUSPENSION

70. Front suspension (photograph D), type Independent - Wishbone
71. Type of spring Coil
72. Stabiliser (if fitted) Torsion
73. Number of shock absorbers 2
74. Type Telescopic Double Acting
78. Rear suspension (photograph E), type Beam Axle Link
79. Type of spring Coil
80. Stabiliser (if fitted) Torsion
81. Number of shock absorbers 2
82. Type Telescopic Double Acting

### BRAKES (photographs F and G)

90. Method of operation Hydraulic
91. Servo-assistance (if fitted), type Vacuum servo
92. Number of hydraulic master cylinders One-dual tandem

		FRONT		One	REAR	
93. Number of cylinders per wheel	Two					
94. Bore of wheel cylinder(s)	50.8	mm.	2 inches		mm.	inches
95. Inside diameter		mm.	inches	228	mm. 9	inches
96. Length of brake linings		mm.	inches	179	mm. 7.06	inches
97. Width of brake linings		mm.	inches	44.5	mm. 1.75	inches
98. Number of shoes per brake						
99. Total area per brake		mm. <sup>2</sup>	sq. in.	166	mm. <sup>2</sup> 25.8	sq. in.

### Disc Brakes

100. Outside diameter	255	mm.	10.03 inches		mm.	inches
101. Thickness of disc	9.6	mm.	0.38 inches		mm.	inches
102. Length of brake linings		mm.	inches		mm.	inches
103. Width of brake linings		mm.	inches		mm.	inches
104. Number of pads per brake						
105. Total area per brake	574	mm. <sup>2</sup>	8.9 sq. in.		mm. <sup>2</sup>	sq. in.

COMMISSION SPORTIVE  
01526 22.1173  
INTERNATIONALE



Make Vauxhall Motors Model Firenza Magnum F.I.A. Rec. No. 5565

**ENGINE** (photographs J and K)

130. Cycle 4 stroke 131. Number of cylinders 4
132. Cylinder Arrangement 45° in line
133. Bore 97.59 mm. 3.842 in. 134. Stroke 76.2 mm. 3 in.
135. Capacity per cylinder 569.7 cm.<sup>3</sup> 34.7 cu. in.
136. Total cylinder capacity 2279 cm.<sup>3</sup> 139 cu. in.
137. Material(s) of cylinder block Chromium Cast Iron 138. Material(s) of sleeves (if fitted) -
139. Cylinder head, material(s) Chromium Cast Iron Number fitted One
140. Number of inlet ports 4 141. Number of exhaust ports 4
142. Compression ratio 8.5
143. Volume of one combustion chamber 50 cm.<sup>3</sup> 3 cu. in.
144. Piston, material Aluminium Alloy 145. Number of rings 3
146. Distance from gudgeon pin centre line to highest point of piston crown 42 mm. 1.63 in.
147. Crankshaft: moulded/stamped 148. Type of crankshaft: integral/Yes
149. Number of crankshaft main bearings 5
150. Material of bearing cap Cast Iron
151. System of lubrication: dry sump/oil in sump
152. Capacity, lubricant 5 ltrs. 8.75 pts. 5.26 quarts U.S.
153. Oil cooler: yes/no 154. Method of engine cooling Water
155. Capacity of cooling system 7.98 ltrs. 14.0 pts. 8.4 quarts U.S.
156. Cooling fan (if fitted) dia. 36 cm. 14 in.
157. Number of blades of cooling fan 5

**Bearings**

158. Crankshaft main, type White Metal/Copper Lead dia. 63.5 m.m. 2.5 in.
159. Connecting rod big end, type Copper Lead Tin dia. 50.8 m.m. 2.0 in.

**Weights**

160. Flywheel (clean) 9.2 kg. 20.3 lbs.
161. Flywheel with clutch (all turning parts) 15 kg. 33 lbs.
162. Crankshaft 17 kg. 37.6 lbs. 163. Connecting rod .78 kg. 1.7 lbs.
164. Piston with rings and pin .83 kg. 1.8 lbs.

COMMISSION SPORTIVE  
01526 22.1173  
INTERNATIONALE

Make Vauxhall Motors

Model Firenze Magnum

F.I.A. Rec. No. 5565

**FOUR STROKE ENGINES**

- 170. Number of camshafts One
- 171. Location Housing on Cylinder Head
- 172. Type of camshaft drive External Toothed Belt
- 173. Type of valve operation Cam inverted Bucket Tappet

**INLET (see page 4)\***

- 180. Material(s) of inlet manifold Aluminium
- 181. Diameter of valves 43 mm. 1.68 ins.
- 182. Max. valve lift 10.6 mm. .420 in.
- 183. Number of valve springs Two
- 184. Type of spring Coil
- 185. Number of valves per cylinder One
- 186. Tappet clearance for checking timing (cold/warm) .10 mm. .004 ins.
- 187. Valves open at (with tolerance for tappet clearance indicated) 31° 36 BTDC .18 .007
- 188. Valves close at (with tolerance for tappet clearance indicated) 63° 36 ABDC
- 189. Air filter, type Paper Element

**EXHAUST (see page 4)\***

- 195. Material(s) of exhaust manifold Cast Iron
- 196. Diameter of valves 36 mm. 1.42 ins.
- 197. Max. valve lift 10.6 mm. .420 in.
- 198. Number of valve springs Two
- 199. Type of spring Coil
- 200. Number of valves per cylinder One
- 201. Tappet clearance for checking timing (cold/warm) .18 mm. .007 ins.
- 202. Valves open at (with tolerance for tappet clearance indicated) 63° 36 BBDC .25 .010
- 203. Valves close at (with tolerance for tappet clearance indicated) 31° 36 ABDC
- 204. Diameter outlet orifice exhaust manifold 48 mm. 1.92 TWIN ins.

**CARBURETION (photograph N)**

- 210. Number of carburettors fitted Two
- 211. Type Variable Choke
- 212. Make Zenith
- 213. Model 175 GD
- 214. Number of mixture passages per carburettor Single V
- 215. Flange hole diameter of exit port(s) of carburettor 44.5 mm. 1.750 ins.
- 216. Minimum diameter of venturi/minimum diam., with piston at maximum height (example : SU) 31.7 mm. 1.25 ins.

**INJECTION (if fitted)**

- 220. Make of pump
- 221. Number of plungers
- 222. Model or type of pump
- 223. Total number of injectors
- 224. Location of injectors
- 225. Minimum diameter of inlet pipe mm. ins.

\* For additional information concerning two-stroke engines and super-charged engines, see page 13.

COMMISSION SPORTIVE  
C1526 22.1173  
INTERNATIONALE



Make Vauxhall Motors

Model Firenza Magnum

F.I.A. Rec. No. 5565

**ENGINE ACCESSORIES**

230. Fuel pump : mechanical ~~and/or electrical~~
231. No. fitted One
232. Type of ignition system Coil                      233. No. of distributors One
234. No. of ignition coils One                      235. No. of spark plugs per cylinder One
236. Generator, type : ~~dynamo~~/alternator—number fitted One
237. Method of drive Belt
238. Voltage of generator 12 volts
239. Battery, number One
240. Location In engine compartment
241. Voltage of battery 12 volts

**ENGINE AND CAR PERFORMANCES** (as declared by manufacturer in catalogue)

250. Max. engine output 128 (type of horsepower: GROSS B.H.P. ) at 5500 r.p.m.
251. Max. r.p.m. output at that figure Not published
252. Max. torque 150 LB/FT at 3300 r.p.m.
253. Max. speed of the car max km./hour miles/hour Not published
254. Reboring dimension .040 ins 1 mm.      255. Resultant cylinder capacity 2327 cm<sup>3</sup>
256. Volume of combustion chamber in head 50 cm<sup>3</sup> 3 cu ins      142 cu ins
257. Thickness of head gasket after tightening 1.28 mm .050 ins.
258. Piston dimensions. 3.809 ins      96.76 mm mean

R = centre of camshaft

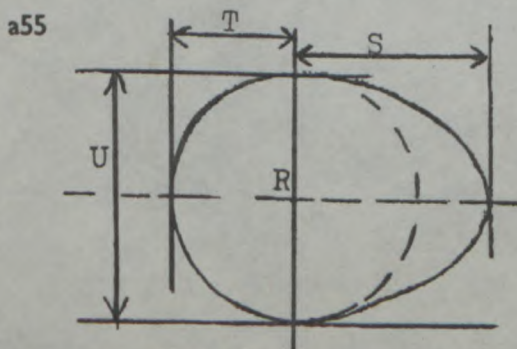

**Inlet cam**

S =	29.5	mm.	1.162	inches
T =	19	mm.	.750	inches
U =	38.1	mm.	1.500	inches

**Exhaust cam**

S =	29.5	mm.	1.162	inches
T =	18.8	mm.	0.750	inches
U =	37.7	mm.	1.487	inches

COMMISSION SPORTIVE  
01526 22.1173  
INTERNATIONALE

Make Vauxhall Motors

Model Firenza Magnum

F.I.A. Rec. No. 5565

**DRIVE TRAIN**

**CLUTCH**

- 260. Type of clutch Diaphragm
- 261. No. of plates One
- 262. Dia. of clutch plates 21.6 cm. 8.5 ins.
- 263. Dia. of linings, inside 15.9 cm. 6.25 ins.
- outside 21.4 cm. 8.44 ins.
- 264. Method of operating clutch Cable Linkage

**GEAR BOX (photograph H)**

- 270. Manual type, make Vauxhall
- 271. No. of gear-box ratios forward 4
- 272. Synchronized forward ratios 4
- 273. Location of gear-shift Floor Central
- 274. Automatic, make General Motors
- 275. No. of forward ratios 3
- Method of operation Lever
- type Code 501
- 276. Location of gear shift Floor Central

277.	Manual		Automatic		Alternative manual/automatic			
	Ratio	No. teeth	Ratio	No. teeth	Ratio	No. teeth	Ratio	No. teeth
1	3.3-1	33/13	2.4 TO	4.8 TO 1	2.52-1	30/14		
2	2.145-1	33/20	1.48 TO	2.9 TO 1	1.76-1	27/18		
3	1.414-1	25/23	1-1 TO	2-1	1.35-1	23/20		
4								
5								
6								
reverse	3.063-1	21/33	1.92-1 TO	3.84 TO 1				

- 278. Overdrive, type
- 279. Forward gears on which overdrive can be selected
- 280. Overdrive ratio

**FINAL DRIVE**

- 290. Type of final drive Hypoid
- 291. Type of differential 2 pinion
- 292. Type of limited slip differential (if fitted in series-production) Friction
- 293. Final drive ratio 3.455-1
- Number of teeth 11/38

COMMISSION SPORTIVE  
01526 22.1173  
INTERNATIONALE



Firenza Magnum 2900  
5565

**IMPORTANT :**

The vehicle described in this form has been subject to the following amendments :

on.....19.....	rec. no.....	List.....	on.....19.....	rec. no.....	List.....
on.....19.....	rec. no.....	List.....	on.....19.....	rec. no.....	List.....
on.....19.....	rec. no.....	List.....	on.....19.....	rec. no.....	List.....
on.....19.....	rec. no.....	List.....	on.....19.....	rec. no.....	List.....
on.....19.....	rec. no.....	List.....	on.....19.....	rec. no.....	List.....

Optional equipment affecting preceding information. This to be stated together with reference number.

Territory options.

Coachlines Decals - Viva, Magnum, Firenza.

Single piece propellor shaft.

50 Type disc.

51 Weight 6.8 kg 15 lb.

52 Method of attachment 4 stud

53 Rim diameter 13 ins. 54 rim width 140 mm 5.5 ins.

78 Heavy duty suspensions. No visible difference.

293 Heavy duty final drive ratio 3.727 11/41

**TOLERANCES**

1. Machined surfaces 1%.
2. Non machined surfaces 2%.
3. Weight of part machined surfaces 2.5%
4. Weights of machined parts 1.5%

COMMISSION SPORTIVE  
01526 . 22.1173  
INTERNATIONALE





MOTOR SPORT DIVISION  
The Royal Automobile Club,  
31 Belgrave Square, London, S.W.1

Manufacturer Vauxhall Motors

Model Firenze Magnum

F.I.A. Recognition No. 5565

Amendment No. 1/W

*Amendment to Form of Recognition*

FEDERATION INTERNATIONALE DE L'AUTOMOBILE **GROUP ONE**

No.	Reference No.	Code 052	Exhaust Emission
142	Compression Ratio	9.2	
143	Combustion chamber volume	44 cm <sup>3</sup>	2.68 cu ins
160	Weight of flywheel	7.1 kg	15.8 lbs
161	Weight of flywheel and clutch	13.3 kg	29.5 lbs
181	Inlet valve diameter	47 mm	1.85 ins
187	Inlet valves open at	39° BBDC	
188	Inlet valves close at	77° ABDC	
196	Exhaust valve diameter	40.5 mm	1.59 ins
202	Exhaust valves open at	77° BBDC	
203	Exhaust valves close at	39° ABDC	
Inlet cam			
	S	28.8 mm	1.133 ins
	T	17.8 mm	0.70 ins
	U	35.6 mm	1.400 ins
Exhaust cam			
	S	28.8 mm	1.133 ins
	T	17.7 mm	0.69 ins
	U	35.6 mm	1.400 ins

Date amendment is valid from 1.5.76

Stamp of F.I.A./R.A.C.



MOTOR SPORT DIVISION  
The Royal Automobile Club,  
21, Whitehall, London, W.1

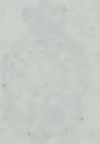

Manufacturer  
Model  
F.I.A. Recognition No.  
Amendment No.

Amendment to Form of Recognition

FEDERATION INTERNATIONALE DE L'AUTOMOBILE

Reference No.

No.

COMMISSION SPORTIVE  
01526 22.1173  
INTERNATIONALE





MOTOR SPORT DIVISION  
The Royal Automobile Club,  
31 Belgrave Square, London, S.W.1

Manufacturer Vauxhall Motors  
Model FIRENZA-MAGNUM  
F.I.A. Recognition No. 5565  
Amendment No. 1/IV

Amendment to Form of Recognition

FEDERATION INTERNATIONALE DE L'AUTOMOBILE GROUP ONE

Photographs must be 3" x 2" and a matt finish

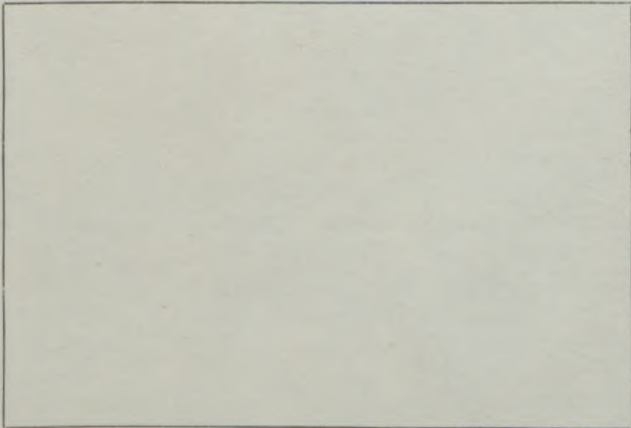
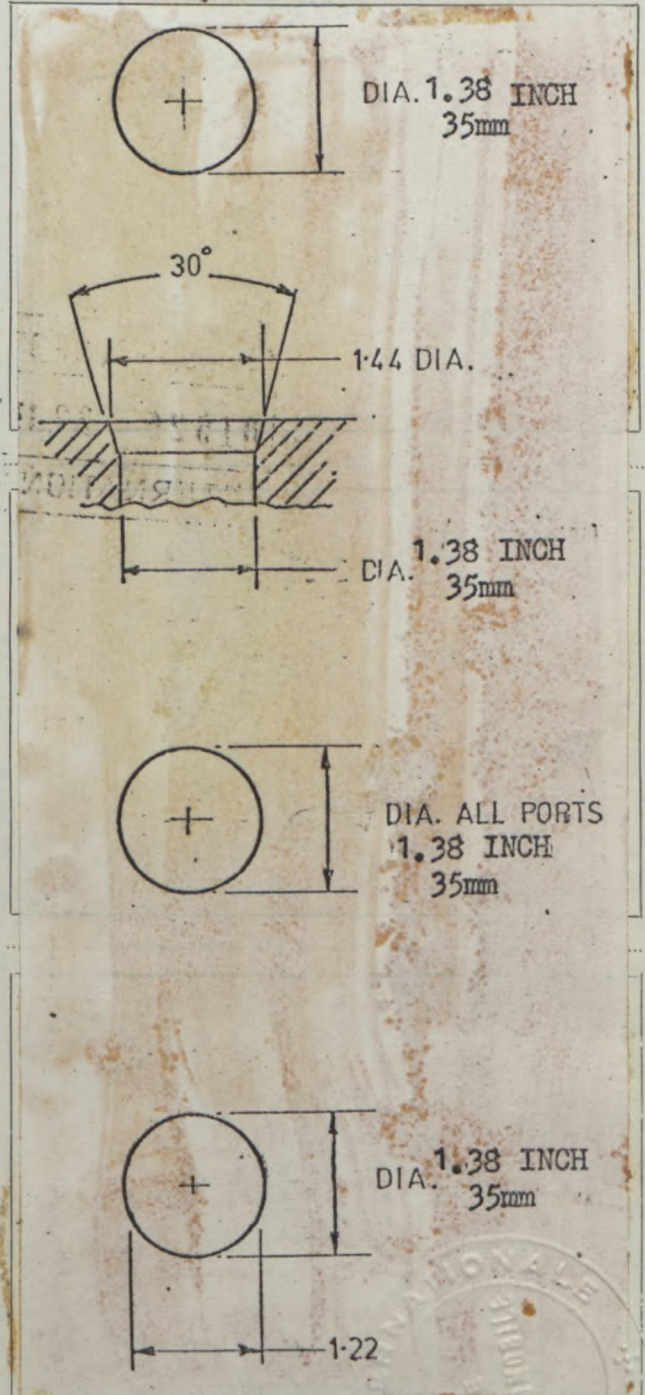

Note: Code 052 Exhaust Emission  
Port and manifold areas fully  
fettled to 2% tolerance  
Tolerances :  $\pm .030$  inches  $.76$  mm

Date amendment is valid from 1.5.76

Stamp of F.I.A./R.A.C.

COMMISSION SPORTIVE  
61526 - 22.1173  
INTERNATIONALE

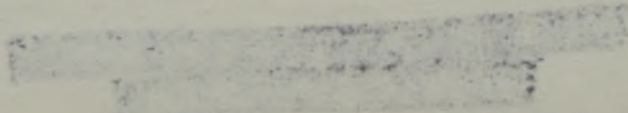



MOTOR SPORT DIVISION  
The Royal Automobile Club,  
31 Belgrave Square, London, S.W.1

Manufacturer Vauxhall Motors  
Model Firenze Magnum  
F.I.A. Recognition No. 5585  
Amendment No. 2/2V

Amendment to Form of Recognition

FEDERATION INTERNATIONALE DE L'AUTOMOBILE

"valable en Groupe 2 uniquement"  
"valid for Group 2 only"

Photographs must be 3"X2" and a matt finish



Supplementary Instrument Panel



Instrument panel cowl



Aluminium Differential Cover

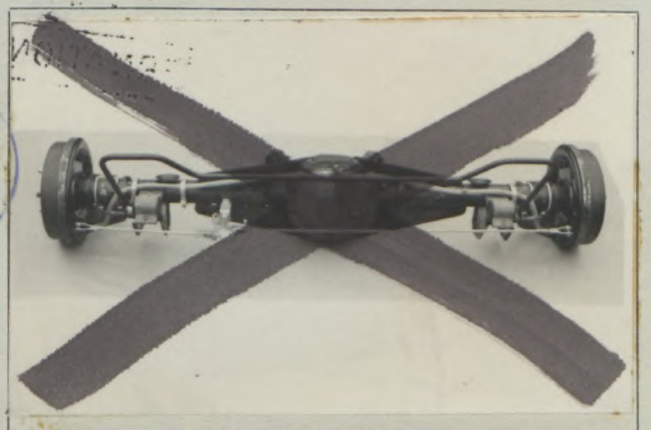

Rally Axle

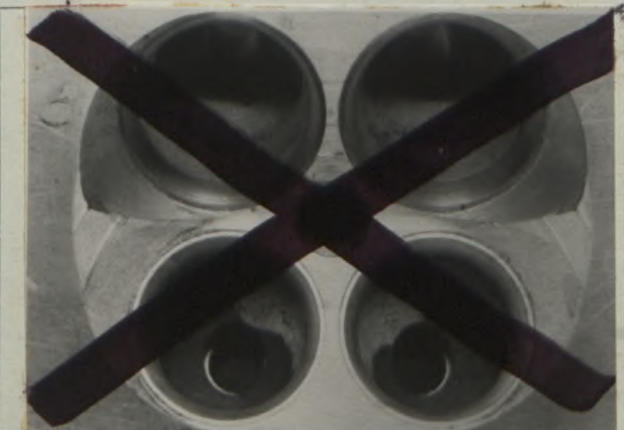

5 speed gearbox

Date amendment is valid from 1.5.74

Stamp of F.I.A./R.A.C.

C. S. I.  
CORRECTION

C. S. I.  
CORRECTION

Stamp of F.I.A./R.A.C. with handwritten signature

Faint, illegible text at the top of the page, possibly bleed-through from the reverse side.



COMMISSION SPORTIVE  
01526 22.1173  
INTERNATIONALE



Faint, illegible text or markings at the bottom center of the page.



MOTOR SPORT DIVISION  
The Royal Automobile Club,  
31 Belgrave Square, London, S.W.1

Manufacturer ..... Vauxhall Motors  
Model ..... Firenza Magnum  
F.I.A. Recognition No. ....  
Amendment No. .... 2/21

Amendment to Form of Recognition

FEDERATION INTERNATIONALE DE L'AUTOMOBILE **GROUP TWO**

Photographs must be 3"X2" and a matt finish

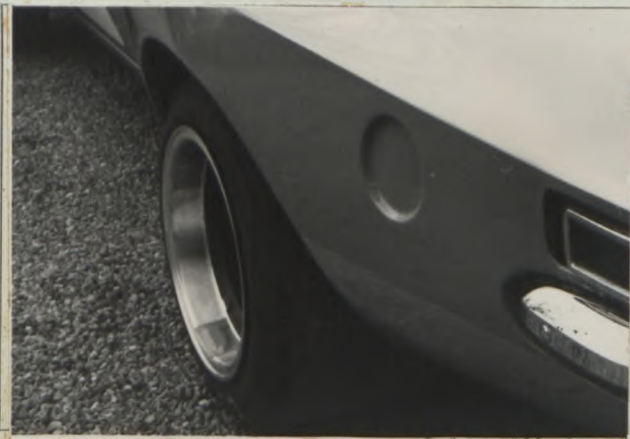

5 cm wing extension



5 cm wing extension



5 cm wing extension



5 cm wing extension



Rally front suspension



Supplementary chassis kit

Date amendment is valid from

valable en Groupe 2 uniquement  
"valid for Group 2 only"

Stamp of F.I.A./R.A.C.

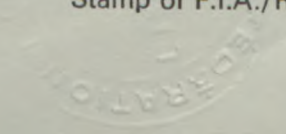

COMMISSION SPORTIVE  
01526 22.1173  
INTERNATIONALE

INTERNATIONALE  
1911



**MOTOR SPORT DIVISION**  
**The Royal Automobile Club**  
**31 Belgrave Square, London SW1X 8QH**

Manufacturer Vauxhall Motors Ltd.

Model Firenza Magnum

F.I.A. Recognition No. 5565

Amendment No. 3/3V

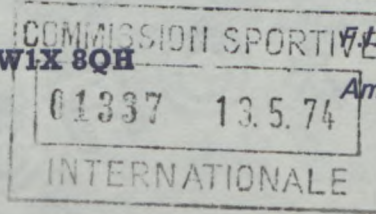

*Amendment to Form of Recognition*

**FEDERATION INTERNATIONALE DE L'AUTOMOBILE**

**VALID IN GROUP ONE**

No.	Reference No.
	Territory option.
293	Final drive ratio 10/39 3.9-1



Date amendment is valid from 1776

Stamp of F.I.A./R.A.C.



**MOTOR SPORT DIVISION**  
**The Royal Automobile Club**  
**31 Belgrave Square, London SW1X 8QH**

Manufacturer Vauxhall Motors Ltd.  
 Model Firenza Magnum 2300  
 F.I.A. Recognition No. 5565  
 Amendment No. h/1E

*Amendment to Form of Recognition*

**FEDERATION INTERNATIONALE DE L'AUTOMOBILE**

**VALID IN GROUP**.....One.....

No. | Reference No.

Errata

Drawing of exit to exhaust port on amendment 1/1V  
 Delete 1.22 in. dimension.

Piston

Gudgeon pin centre to piston crown should read:- 39 mm 1.54 ins.

COMMISSION SPORTIVE  
 02382 02.9.74  
 INTERNATIONALE



Date amendment is valid from 1.10.74

Stamp of F.I.A./R.A.C.



**MOTOR SPORT DIVISION**  
**The Royal Automobile Club**  
**31 Belgrave Square, London SW1X 8QH**

Manufacturer Vauxhall Motors Ltd.

Model Firenza Magnum 2300  
 F.I.A. Recognition No. 5565  
 Amendment No. 5/4V  
 COMMISSION SPORTIVE  
 02555 30.9.74  
 INTERNATIONALE

*Amendment to Form of Recognition*

**FEDERATION INTERNATIONALE DE L'AUTOMOBILE**

**VALID IN GROUP Two**

No.	Reference No.
	<u>Rear brake - optional heavy duty axle - picture 1</u>
97	57.15 mm 2.25 ins 205 mm 31.7 sq. ins.

*"valable en Groupe 2 uniquement"*  
*"valid for Group 2 only"*

COMMISSION SPORTIVE  
 02382 02.9.74  
 INTERNATIONALE



Date amendment is valid from 1.10.76

Stamp of F.I.A./R.A.C.



**MOTOR SPORT DIVISION**  
**The Royal Automobile Club**  
 31 Belgrave Square, London SW1X 8QH

COMMISSION SPORTIVE  
 Manufacturer Vauxhall Motors Ltd.,  
 Model Firenza Magnum 2300  
 02555 30.0.74 F.I.A. Recognition No. 5565  
 INTERNATIONAL Amendment No. 5/AV

*Amendment to Form of Recognition*

FEDERATION INTERNATIONALE DE L'AUTOMOBILE

GROUP ONE

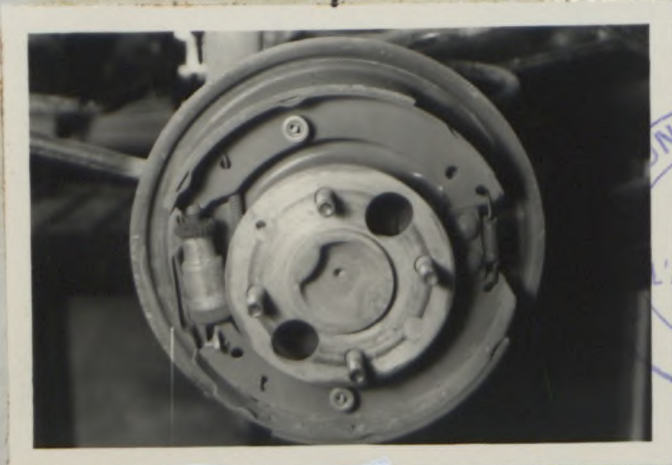

Rear brake



Front brake

be 3" x 2"  
 F.I.A. DE L'AUTOMOBILE



Oil cooler

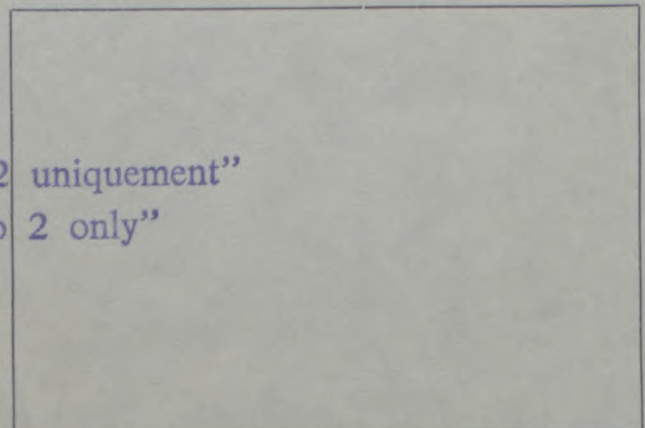
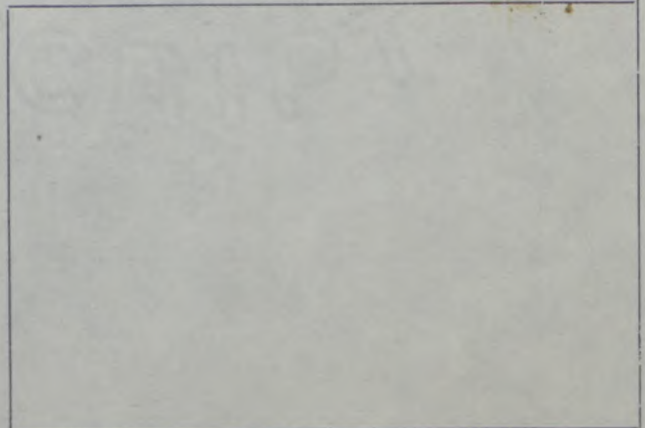

"valable en Groupe 2 uniquement"  
 "valid for Group 2 only"

Date amendment is valid from.....

Stamp of F.I.A./R.A.C.



**MOTOR SPORT DIVISION**  
**The Royal Automobile Club**  
**31 Belgrave Square, London SW1X 8QH**

Manufacturer Vauxhall Motors Ltd.

Model Firenza Magnum 2300

COMMISSION SPORTIVE  
 02555 30.9.74  
 INTERNATIONALE  
 F.I.A. Recognition No. 5565  
 Amendment No. G/5V

*Amendment to Form of Recognition*

**FEDERATION INTERNATIONALE DE L'AUTOMOBILE**

**VALID IN GROUP.....TWO.....**

No.	Reference No.
	16 valve cylinder head - picture one.
139	Aluminium alloy
170	2
171	On cylinder head
172	Toothed belt
173	Camshaft and tappet
185	2
200	2
	Reinforced axle unit - picture two.

"valable en Groupe 2 uniquement"

"valid for Group 2 only"

Date amendment is valid from 1.10.76



Stamp of F.I.A./R.A.C.



**MOTOR SPORT DIVISION**  
**The Royal Automobile Club**  
**31 Belgrave Square, London SW1X 8QH**

Manufacturer Vauxhall Motors Ltd  
 Model Firenze Magnum 2300  
 F.I.A. Recognition No. 5565  
 Amendment No. 6/SV

*Amendment to Form of Recognition*

**FEDERATION INTERNATIONALE DE L'AUTOMOBILE**

**GROUP TWO**

**2**

Photographs must be 3" x 2" and a matt finish

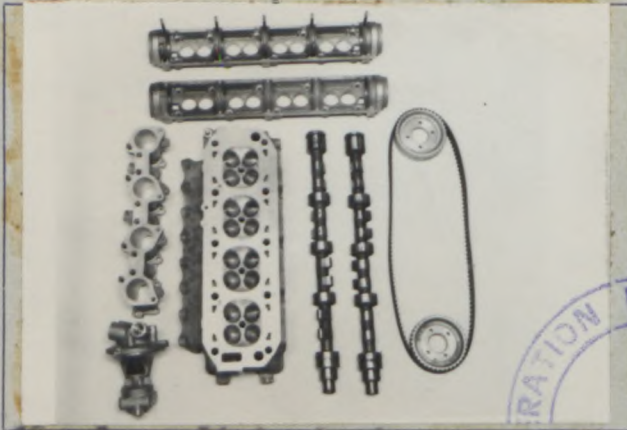

16 valve cylinder head

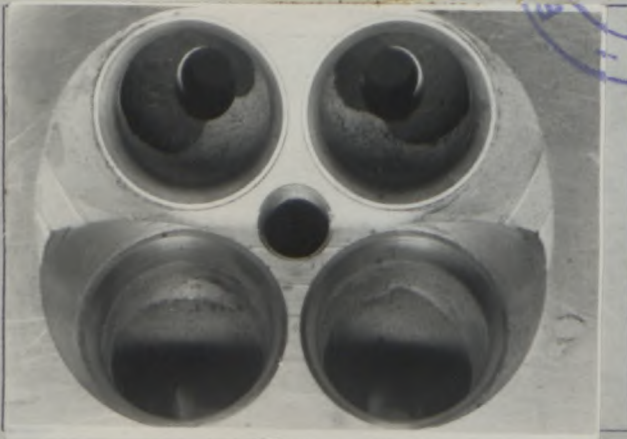

"valable en Groupe 2 uniquement"  
 "valid for Group 2 only"

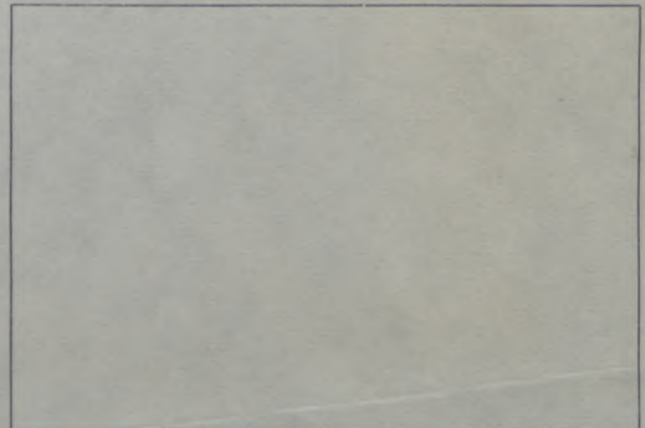
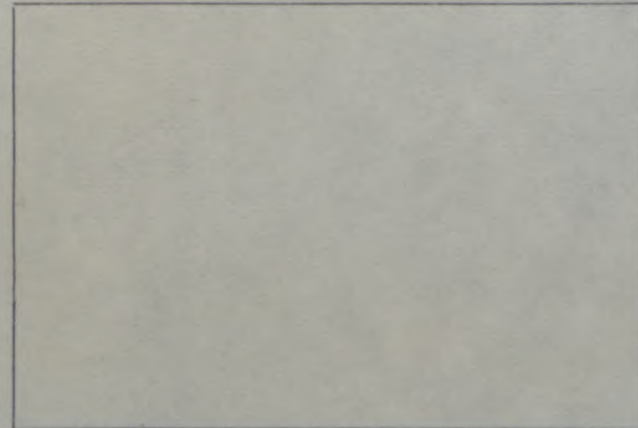

Date amendment is valid from.....

Stamp of F.I.A./R.A.C.



**MOTOR SPORT DIVISION**  
**The Royal Automobile Club**  
**31 Belgrave Square, London SW1X 8QH**

COMMISSION SPORTIVE  
 02555 30.9.74  
 INTERNATIONAL

Manufacturer VAUXHALL MOTORS  
 Model FIRENZA MAGNUM 2300  
 F.I.A. Recognition No. 5565  
 Amendment No. 7/2E

*Amendment to Form of Recognition*

**FEDERATION INTERNATIONALE DE L'AUTOMOBILE**  
**VALID IN GROUP ONE**

No.	Reference No.
	<u>EVOLUTION</u>
39	<u>CYLINDER HEAD</u> - PART NO. 33766 VALVE GUIDE LENGTH REDUCED BY 0.180 INS. 4.5 MM. VALVE ROTATORS DELETED NO OTHER SPECIFICATION CHANGE
A55	<u>CAMSHAFT</u> - PART NO. 33734 AMENDMENT I/IV INLET EXHAUST
	S 28.8 MM. 1.133 INS.      S 28.8 MM. 1.133 INS.
	T 17.8 MM. 0.700 INS.      T 17.7 MM. 0.690 INS.
	U 35.6 MM. 1.400 INS.      U 35.2 MM. 1.386 INS.
90	<u>FRONT BRAKE</u>
94	PRESSURE BALANCING VALVE ADDED TO SYSTEM
101	BORE OF WHEEL CYLINDER 58 MM. 2.283 INS.
105	697 MM <sup>2</sup> 10.8 SQ.INS.
	<u>CLUTCH</u>
262	DIA OF CLUTCH PLATE 24 CM. 9.5 INS.
263	DIA OF LININGS - INSIDE 15.8 CM. 6.12 INS. - OUTSIDE 24 CM. 9.5 INS.

Date amendment is valid from 1.10.76





**MOTOR SPORT DIVISION**  
**The Royal Automobile Club**  
**31 Belgrave Square, London SW1X 8QH**

Manufacture VAUXHALL MIRA LTD  
 Model FIRENZA - MAGNUM  
 F.I.A. Recognition No. 5565  
 Amendment No. 8/3E

*Amendment to Form of Recognition*

**FEDERATION INTERNATIONALE DE L'AUTOMOBILE**

**VALID IN GROUP... ONE.....**

No.	Reference No.
94	ERRATA BORE OF WHEEL CYLINDER. REAR. 22.2 MM. .88 in



Date amendment is valid from 1.1.75

Stamp of F.I.A./R.A.C.





**MOTOR SPORT DIVISION**  
**The Royal Automobile Club**  
**31 Belgrave Square, London SW1X 8QH**

Manufacturer Vauxhall Motors Ltd.  
 Model Magnum Firenze  
 F.I.A. Recognition No. 5565  
 Amendment No. 9/6V

*Amendment to Form of Recognition*

**FEDERATION INTERNATIONALE DE L'AUTOMOBILE**

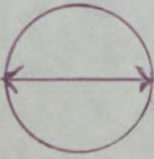
**VALID IN GROUP... ONE .....**

No.	Reference No.		
	<u>Inlet Manifold</u> - kit no. 25177		Photo 8
180	Aluminium		
		36 mm dia 1.42 ins port on cylinder head side Tolerance $\pm$ .76 mm .030 ins	
189	<u>Air filter</u> - kit no. 25177		Photo 8
	wire mesh		
195	<u>Exhaust manifold</u> - part no. 25177		Photo 9
	dia 36 mm 1.425 ins		
		port on cylinder head side Tolerance $\pm$ .76 mm .030 ins	
204	45 mm x 2 = 1.720 ins		
	<u>Carbuartion</u> - kit no. 25177		Photo 8
210	2	211	Venturi
212	Del Orto	213	DHLA
214	2	215	48 mm
216	48 mm		
	<u>Oil cooler</u> - part no. 71211		Photo 10



Date amendment is valid from 1.4.75

Stamp of F.I.A./R.A.C.



**MOTOR SPORT DIVISION**  
**The Royal Automobile Club**  
**31 Belgrave Square, London SW1X 8QH**

Manufacturer Vauxhall Motors Ltd.  
 Model Magnum Firenze  
 F.I.A. Recognition No. 5565  
 Amendment No. 9/6V

*Amendment to Form of Recognition*

**FEDERATION INTERNATIONALE DE L'AUTOMOBILE**

VALID IN GROUP... ONE .....

No.	Reference No.				
	<u>Gearbox</u> - part no. 1255-003-080.				Photo 11
270	Manual	271 5		272 5	
277	1 2.99 to 1	27/34		2 1.76 to 1	25/36
	3 1.3 to 1	31/30		4 Direct	
	5 0.87 to 1	38/16		R 3.67 to 1	32/11/19
291	<u>Final Drive Ratio</u>				
	4.1 to 1	8/33	(supercedes 3.9 to 1)		
	<u>Sump guard</u> - part no. 56144				Photo 12
	63 cm	22.7 ins			
	45.7 cm	18 ins	x 1.6 mm	5 Kg	11 lbs
	<u>Tank guard</u> - part no. 56223				Photo 13
	70 cm	27.5 ins			
	53 cm	21 ins		5.9 Kg	13 lbs



Date amendment is valid from.....

Stamp of F.I.A./R.A.C.



**MOTOR SPORT DIVISION**  
**The Royal Automobile Club**  
**31 Belgrave Square, London SW1X 8QH**

Manufacturer Vauxhall Motors Ltd.  
 Model Firenza Magnum  
 F.I.A. Recognition No. 5565  
 Amendment No. 9/6V

*Amendment to Form of Recognition*

**FEDERATION INTERNATIONALE DE L'AUTOMOBILE**

Photographs must be 3" x 2" and a matt finish



(8) Carb. inlet man. air filter part no. 25177



(9) Exhaust manifold part no. 25177

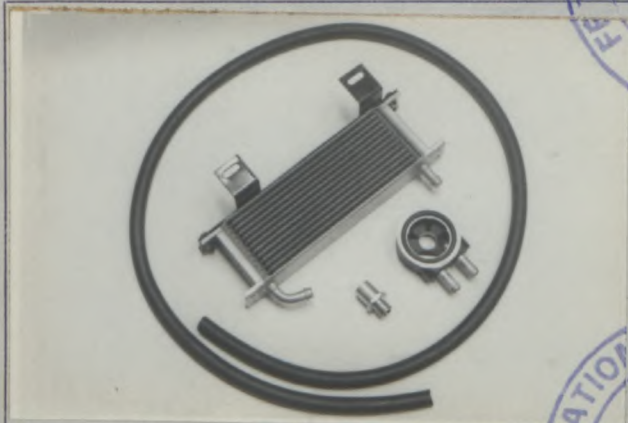

(10) Oil cooler part no. 71211

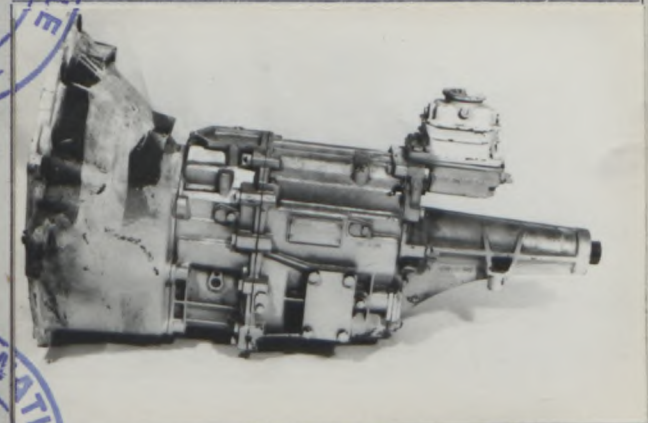

(11) Gearbox part no. 1255-005-080

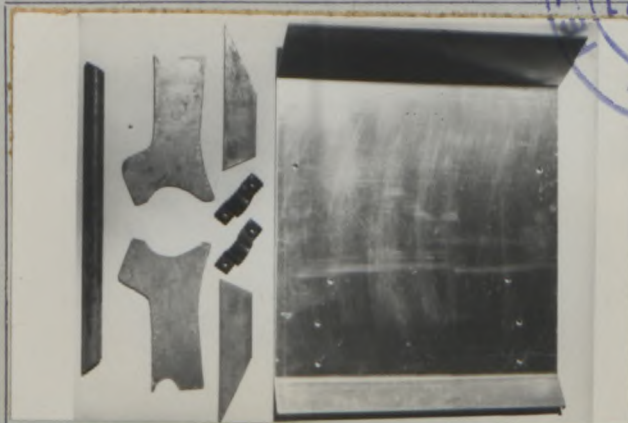

(12) Sump guard part no. 56144



(13) Tank guard part no. 56223

Date amendment is valid from.....

Stamp of F.I.A./R.A.C.



**MOTOR SPORT DIVISION**  
**The Royal Automobile Club**  
**31 Belgrave Square, London SW1X 8QH**

Manufacturer Vauxhall Motors Ltd.  
 Model Magnum Firenze  
 F.I.A. Recognition No. 5565  
 Amendment No. 10/7V

*Amendment to Form of Recognition*

**FEDERATION INTERNATIONALE DE L'AUTOMOBILE**

**VALID IN GROUP... TWO.....**

No.	Reference No.	<i>"valable en Groupe 2 uniquement"</i>				
<del><u>Clutch - part no. 46199</u> <i>"valid for Group 2 only"</i> Photo 1</del>						
260	Diaphragm	261	3			
262	197 mm 1.75 ins	263	18.4 cm 7.25 ins	13.3 cm 5.25 ins		
<del><u>Aluminium Clutch Housing - part no. 46201</u> Photo 2</del>						
<del><u>Rear Disc Brake Conversion - part no. 44322</u> Photo 3</del>						
100	257 mm 10.12 ins	101	12.7 mm	0.5 ins		
102	76 mm 3 ins	52 mm 2.1 ins	103	55.5 mm	2.2 ins	
104	2	105	696 mm <sup>2</sup>	10.8 ins <sup>2</sup>		
94	44.5 mm x 2 = 1.75 ins					
<del><u>Ventilated Discs - part no. 54966</u> Photo 4</del>						
100	257 mm 10.12 ins	101	21 mm	820 ins		
102	114 mm 4.5 ins	103	43 mm	1.7 ins		
104	2	105	838 mm <sup>2</sup>	13 ins <sup>2</sup>		
94	1.475 x 4					

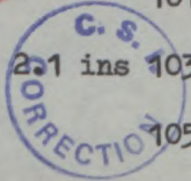

~~no. 55888 Photo 5~~



Stamp of F.I.A./R.A.C.



Date amend



**MOTOR SPORT DIVISION**  
**The Royal Automobile Club**  
**31 Belgrave Square, London SW1X 8QH**

Manufacturer Vauxhall Motors Ltd.  
 Model Magnum Firenza  
 F.I.A. Recognition No. 5565  
 Amendment No. 10/7V

*Amendment to Form of Recognition*

**FEDERATION INTERNATIONALE DE L'AUTOMOBILE**

VALID IN GROUP.....TWO.....

No.	Reference No.	<i>"valable en Groupe 2 uniquement"</i>		
	<u>Crankshaft</u> - kit no. 33799	<i>"valid for Group 2 only"</i>		Photo 6
147	Forged steel	148	Integral	
162	17.8 Kg      39.5 lbs			
	<u>Connecting rods</u> - kit no. 33799			Photo 6
163	0.8 Kg      1.75 lbs Steel			
	<u>Bearing caps</u> - kit no. 33799			Photo 6
150	Steel			
	<u>Dry sump equipment</u> Part no. 71422			Photo 7
	Includes pump, filter and tank.			



Date amendment is valid from.....

Stamp of F.I.A./R.A.C.



**MOTOR SPORT DIVISION**  
**The Royal Automobile Club**  
 31 Belgrave Square, London SW1X 8QH

Manufacturer Vauxhall Motors Ltd.  
 Model Firenza Magnum  
 F.I.A. Recognition No. 5565  
 Amendment No. 10/7V

Amendment to Form of Recognition

FEDERATION INTERNATIONALE DE L'AUTOMOBILE

"valable en Groupe 2 uniquement"  
 "valid for Group 2 only"

Photographs must be 3" x 2" and a matt finish

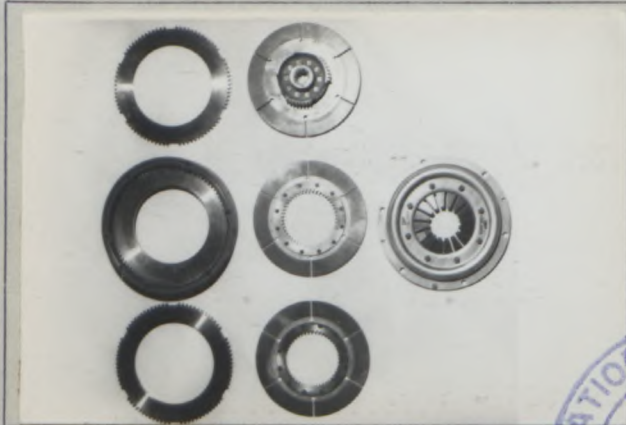

(1) Clutch part no. 46199

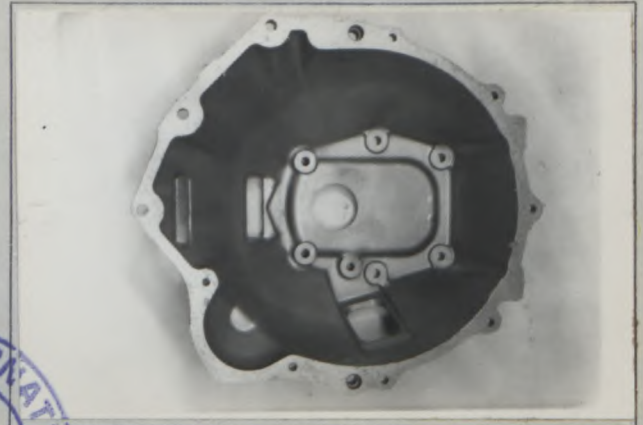

(2) Clutch housing part no. 46201

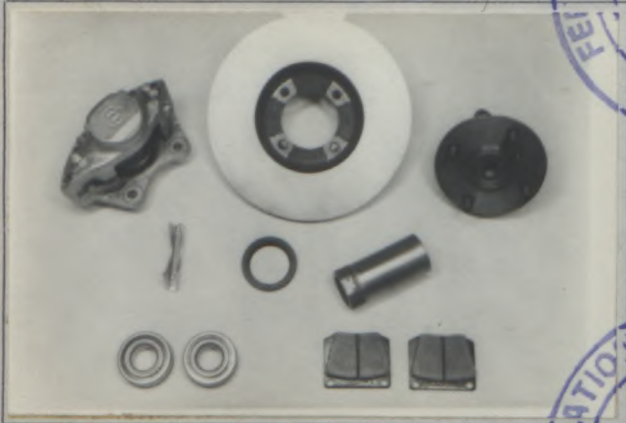

(3) Rear disc brake part no. 44322

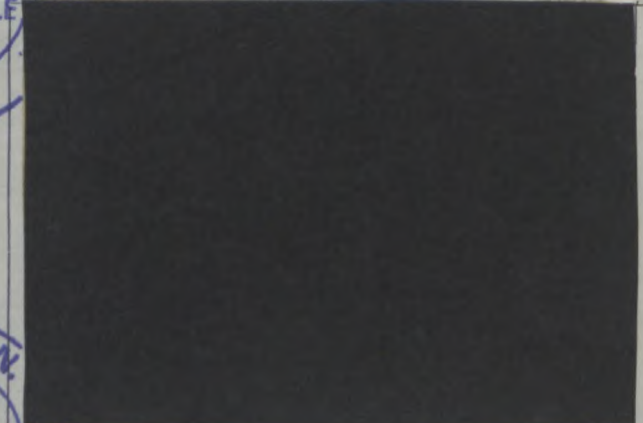

(4) Ventilated discs part no. 54966

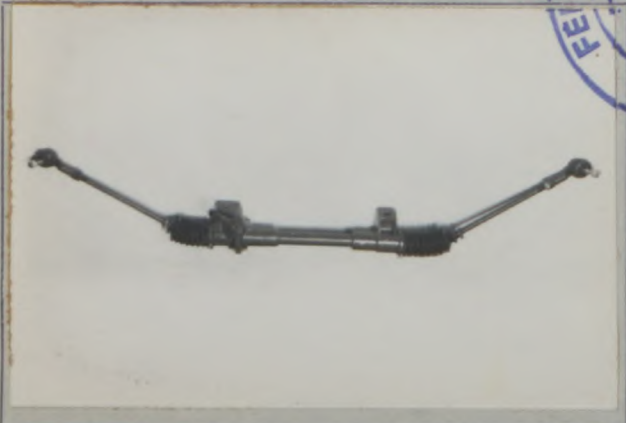

(5) Steering rack part no. 55888

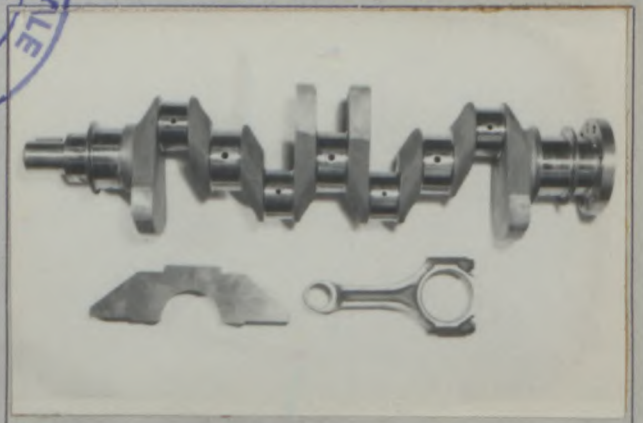

(6) Crankshaft con rod bearing cap  
 Part no. 33799

Date amendment is valid from.....

Stamp of F.I.A./R.A.C.





**MOTOR SPORT DIVISION**  
**The Royal Automobile Club**  
**31 Belgrave Square, London SW1X 8QH**

Manufacturer Vauxhall Motors Ltd.  
 Model Firenza Magnum  
 F.I.A. Recognition No. 5565  
 Amendment No. 10/3V

*Amendment to Form of Recognition*

**FEDERATION INTERNATIONALE DE L'AUTOMOBILE**

Photographs must be 3" x 2" and a matt finish

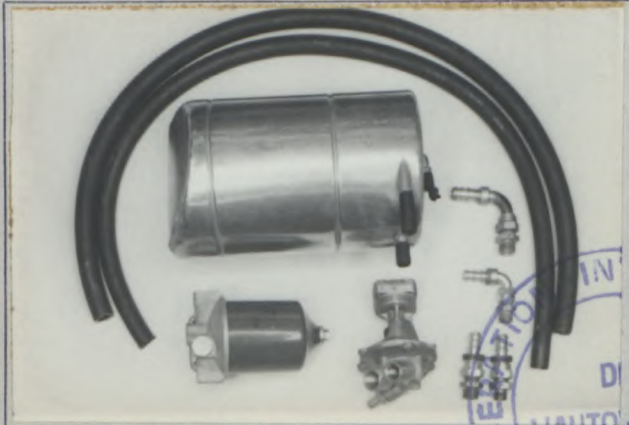

(7) Dry sump equipment part no. ....



"valable en Groupe 2 uniquement"  
 "valid for Group 2 only"

Date amendment is valid from.....

Stamp of F.I.A./R.A.C.



**MOTOR SPORT DIVISION**  
**The Royal Automobile Club**  
**31 Belgrave Square, London SW1X 8QH**

Manufacturer Vauxhall Motors  
 Model Firenza - Magnum  
 F.I.A. Recognition No. 5565  
 Amendment No. 11/8V

*Amendment to Form of Recognition*

**FEDERATION INTERNATIONALE DE L'AUTOMOBILE**

**VALID IN GROUP** One

No.	Reference No.	Variant.	
		Alternator bracket for repositioned heavy duty alternator. Part no. 66/122	<u>Picture two</u>
230		Fuel pump. Electric fuel pump alternative. Part no. 66/133	
		<del>XXXXXXXXXX</del> <del>XXXXXXXXXX</del>	
41		Drivers seat alternative Part no. 77/433 or 77/833	Manufacturer: Corbeau Short Back: 32lbs; 14.5kgs Long Back : 26lbs; 11.8kgs <u>Picture three</u>
51		Alternative wheel	
53		6.4 Kg            14 lbs	
54		330 mm           13 ins	
		152.4 mm        6 ins	
		Part no. 91010724	<u>Picture four</u>
		Track front and rear 53 ins    1345 mm	



Date amendment is valid from 1.4.76

Stamp of F.I.A./R.A.C.



**MOTOR SPORT DIVISION**  
**The Royal Automobile Club**  
**31 Belgrave Square, London SW1X 8QH**

Manufacturer Vauxhall Motors  
 Model Firenza - Magnum  
 F.I.A. Recognition No. 5565  
 Amendment No. 11/8V

*Amendment to Form of Recognition*

**FEDERATION INTERNATIONALE DE L'AUTOMOBILE**

Photographs must be 3" x 2" and a matt finish

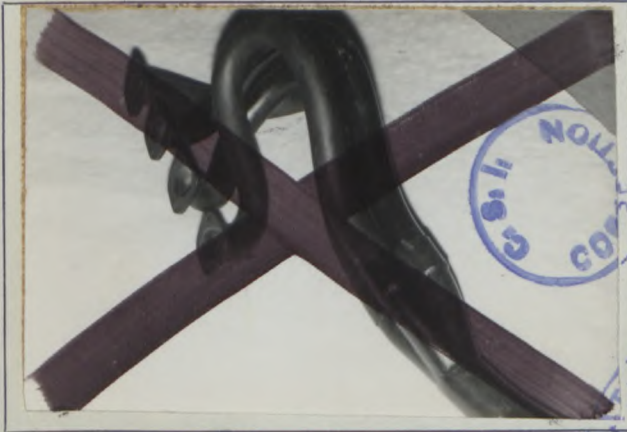

One

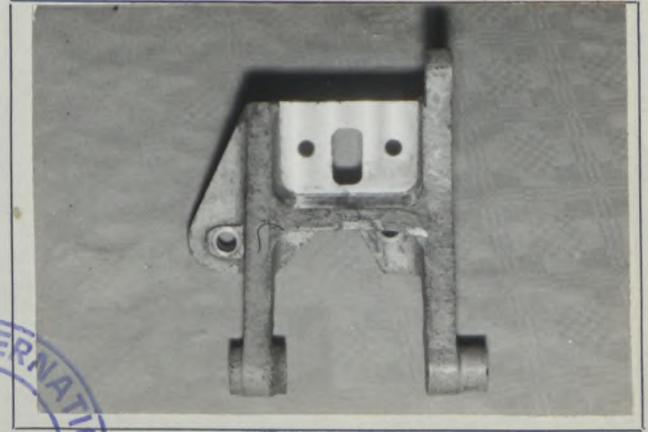

Two



Three



Four

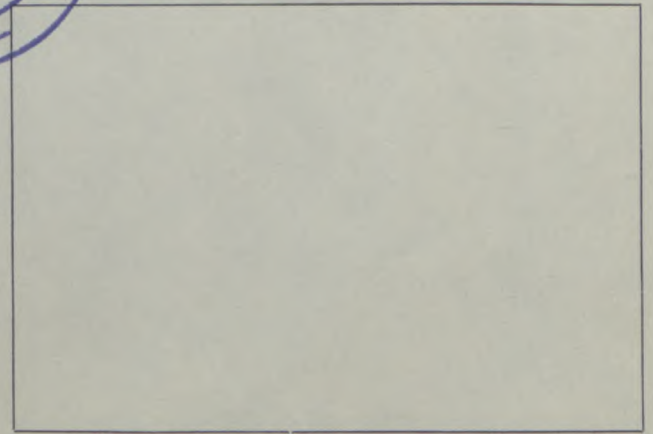
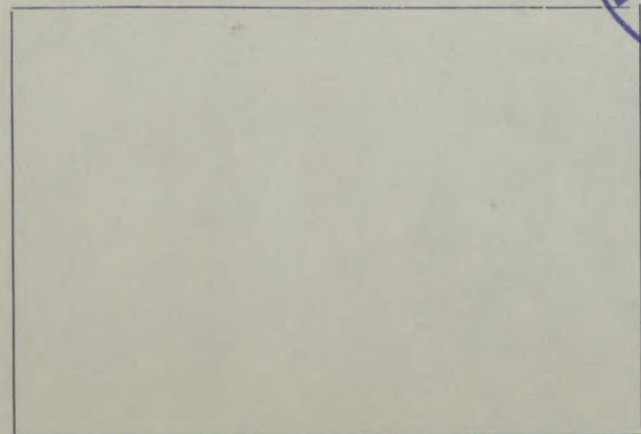

Date amendment is valid from.....

Stamp of F.I.A./R.A.C.



**MOTOR SPORT DIVISION**  
**The Royal Automobile Club**  
**31 Belgrave Square, London SW1X 8QH**

Manufacturer Vauxhall Motors Ltd

Model Firenza Magnum

F.I.A. Recognition No. 5565

Amendment No. 12/9V

*Amendment to Form of Recognition*

**FEDERATION INTERNATIONALE DE L'AUTOMOBILE**

**Valid in Group** One

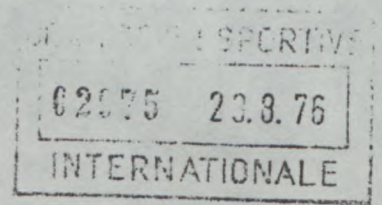

No.	Reference No.
	Alternative Exhaust System.
	Part Nos. 9967310, 91009391, 91010072.



Date amendment is valid from 1.11.76

Stamp of F.I.A./R.A.C



**MOTOR SPORT DIVISION**  
**The Royal Automobile Club**  
**31 Belgrave Square, London SW1X 8QH**

Manufacturer VAUXHALL MOTORS LTD.  
 Model FIRENZA MAGNUM  
 F.I.A. Recognition No. 5565  
 Amendment No. 1314E

Amendment to Form of Recognition

FEDERATION INTERNATIONALE DE L'AUTOMOBILE

Valid in Group ONE

No. Reference No.

EVOLUTION

140

INLET PORT - REFER TO PAGE 14 ILLUSTRATION  
 DIAMETER DIMENSION\* INCREASED BY 0.06" TO 1.50" DIA.  
 FROM AUGUST 1975  
 ALL OTHER DETAILS REMAIN THE SAME.

NOTE:

CODE 052 EXHAUST EMISSION PORT  
 & MANIFOLD AREA FULLY FETTLED  
 TO 2% TOLERANCE  
 TOLERANCE  $\pm$  .030 INS  
 .76 MM

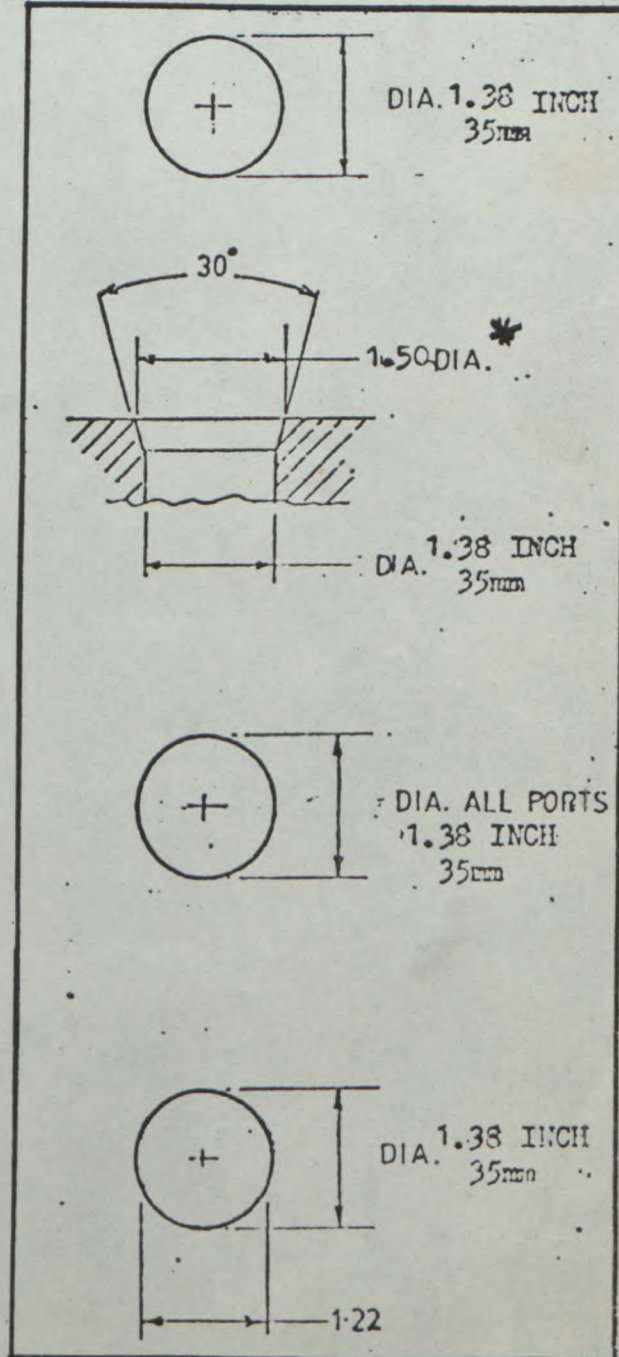

Date amendment is valid from 1.4.77

Stamp of F.I.A./R.A.C



**MOTOR SPORT DIVISION**  
**The Royal Automobile Club**  
**31 Belgrave Square, London SW1X 8QH**

Manufacturer VAUXHALL MOTORS LTD.  
 Model FIRENZA MAGNUM  
 F.I.A. Recognition No. 5565  
 Amendment No. 13/4E

*Amendment to Form of Recognition*

**FEDERATION INTERNATIONALE DE L'AUTOMOBILE**

**Valid in Group** ONE

No.	Reference No.																														
	<u>STEERING RACK</u> - PART NUMBER 55-888																														
62	2.75 TURNS OF STEERING WHEEL FROM LOCK TO LOCK																														
	<u>GEARBOX</u> - PART NUMBER 1255 - 003 - 080																														
277	<table border="0"> <tr> <td>1</td> <td>2.30</td> <td>TO</td> <td>1</td> <td>16/38</td> <td>2</td> <td>1.80</td> <td>TO</td> <td>1</td> <td>21/39</td> </tr> <tr> <td>3</td> <td>1.36</td> <td>TO</td> <td>1</td> <td>25/35</td> <td>4</td> <td>1.14</td> <td>TO</td> <td>1</td> <td>30/28</td> </tr> <tr> <td>5</td> <td>DIRECT</td> <td></td> <td></td> <td>(28/33)</td> <td>R</td> <td>2.82</td> <td>TO</td> <td>1</td> <td>11/19/32</td> </tr> </table>	1	2.30	TO	1	16/38	2	1.80	TO	1	21/39	3	1.36	TO	1	25/35	4	1.14	TO	1	30/28	5	DIRECT			(28/33)	R	2.82	TO	1	11/19/32
1	2.30	TO	1	16/38	2	1.80	TO	1	21/39																						
3	1.36	TO	1	25/35	4	1.14	TO	1	30/28																						
5	DIRECT			(28/33)	R	2.82	TO	1	11/19/32																						
	DELETE DETAILS OF MANUAL RATIOS, PAGE 11																														
	<u>TERRITORY OPTIONS</u>																														
	COACHWORK BADGES: VIVA 2300 GLS																														



Date amendment is valid from 1.4.77

Stamp of F.I.A./R.A.C



**MOTOR SPORT DIVISION**  
**The Royal Automobile Club**  
**31 Belgrave Square, London SW1X 8QH**

Manufacturer ..... VAUXHALL  
 Model ..... MAGNUM - FIRENZA  
 F.I.A. Recognition No. .... 5565  
 Amendment No. .... 14/10V

*Amendment to Form of Recognition*

**FEDERATION INTERNATIONALE DE L'AUTOMOBILE**

**Valid in Group** ONE

No. | Reference No.

PEDAL BOX Part No. 54199

FOR DUAL BRAKING SYSTEM.

IN ACCORDANCE WITH ART. 258 (1).



Date amendment is valid from..... 1.7.77

Stamp of F.I.A./R.A.C



**MOTOR SPORT DIVISION**  
**The Royal Automobile Club**  
**31 Belgrave Square, London SW1X 8QH**

Manufacturer VAUXHALL  
 Model MAGNUM - FIRENZA  
 F.I.A. Recognition No. 5565  
 Amendment No. 14/10V

*Amendment to Form of Recognition*

**FEDERATION INTERNATIONALE DE L'AUTOMOBILE**

**Valid in Group** ONE

Photographs must be 3" x 2" and a matt finish



PEDAL BOX - Part No. 544199.

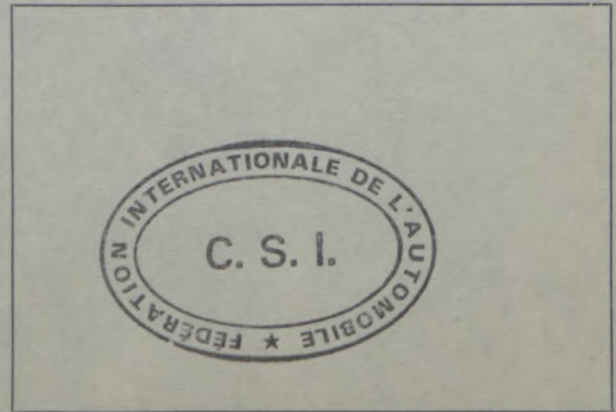
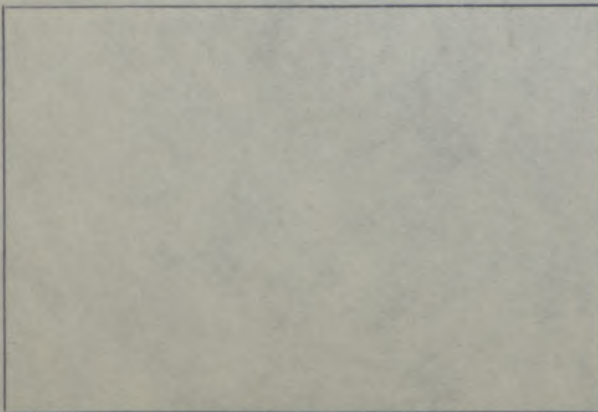
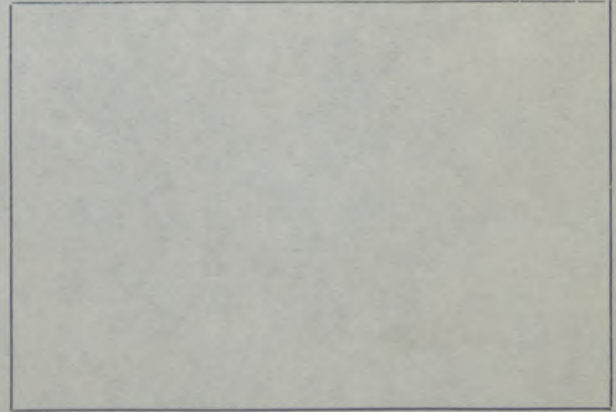
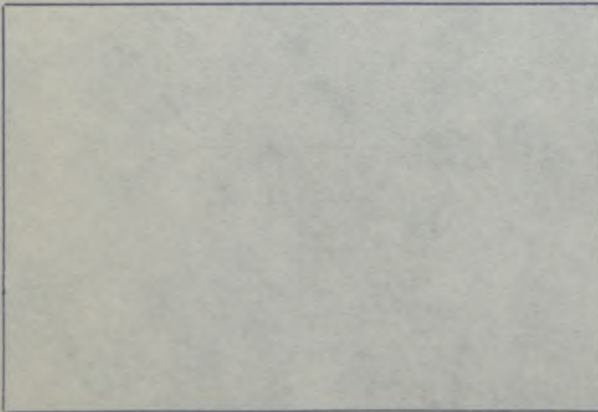
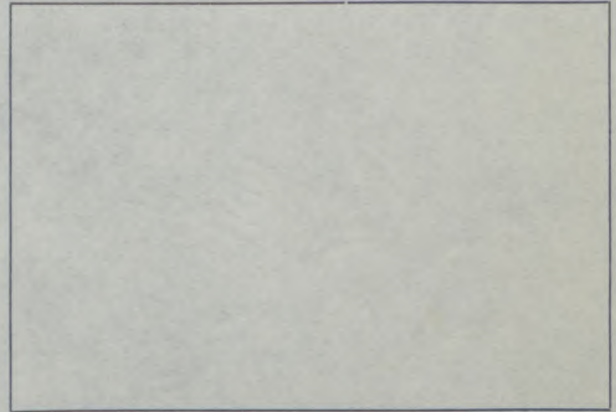

Date amendment is valid from.....

Stamp of F.I.A./R.A.C.