



FEDERATION INTERNATIONALE
DU SPORT AUTOMOBILE

Homologation No

F3-3171

FICHE D'HOMOLOGATION POUR MOTEUR DE FORMULE 3
HOMOLOGATION FORM FOR FORMULA 3 ENGINE

Constructeur FORD Modèle et type ESCORT RS COSWORTH
Manufacturer Model and type
Engine Type - YB

Homologation valable à partir du 1 JAN 1995
Homologation valid as from

MOTEUR (version standard)
ENGINE (standard version)

Cycle 4 Stroke
Cycle

Nombre et disposition des cylindres 4 in Line
Number and layout of the cylinders

Mode de refroidissement Liquid by forced circulation
Cooling system

Cylindrée: Unitaire 498.5 cm3 Totale 1994.5 cm3
Cylinder capacity: Unitary Total

Matériau du bloc cylindres Ferrous
Cylinder block material

Chemises: oui Type Repair sleeve only - dry liner
Sleeves: yes Type

Alésage 90.8 mm Course 77.0 mm
Bore Stroke

© FISA - FC - 1990 - 002.03_FB.07.92

FEDERATION INTERNATIONALE
DE L'AUTOMOBILE
8, Place de la Concorde, 8
75008 PARIS

Marque FORD
 Make _____

Modèle ESCORT RS COSWORTH
 Model _____
 Type YB

F3-317

Vilebrequin:
 Crankshaft:

Type de paliers Plain
 Type of bearings _____

Matériau des chapeaux de paliers Ferrous
 Bearing cap material _____

Culasse:
 Cylinder head:

Nombre 1 Emplacement _____
 Number _____ Location _____

Système de commande des soupapes Direct Acting Tappets
 Type of valve operation _____

Angle entre axe de la soupape d'admission et axe de la soupape d'échappement 45°
 Angle between inlet valve axle and exhaust valve axle _____

Admission:
 Inlet:

Nombre de soupapes par cylindre 2 Type des ressorts de soupape Coil
 Number of valves per cylinder _____ Type of valve springs _____

Echappement:
 Exhaust:

Nombre de soupapes par cylindre 2 Type des ressorts de soupape Coil
 Number of valves per cylinder _____ Type of valve springs _____

PHOTOS

Culasse nue vue de dessus
 Bare cylinder head seen from above

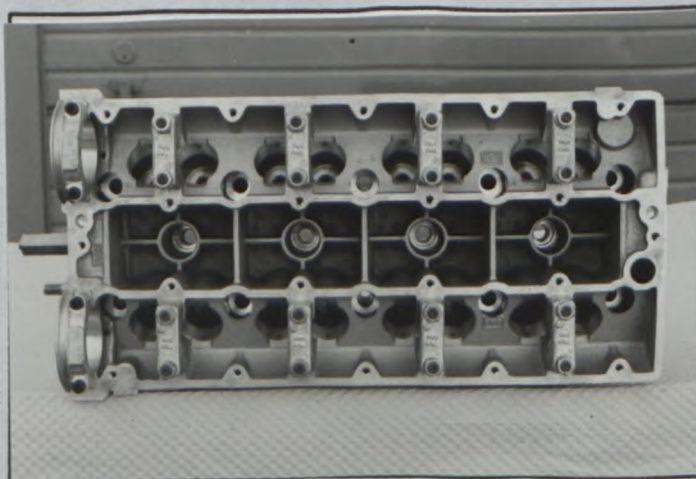

Culasse nue vue de dessous
 Bare cylinder head seen from below

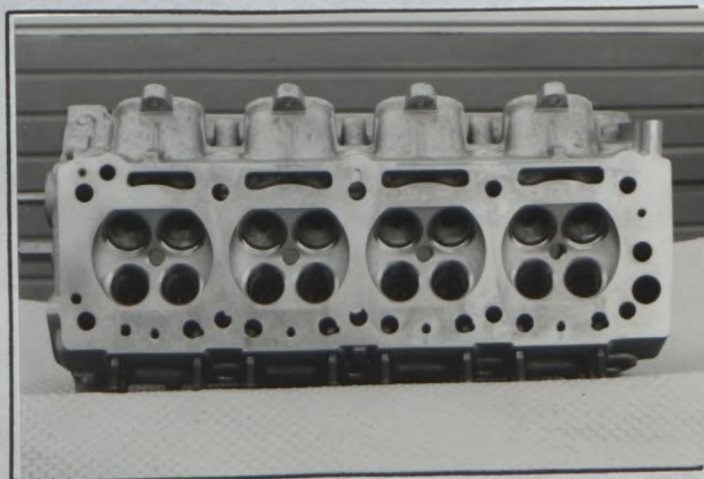

Marque
Make

FORD

Modèle
Model

ESCORT RS COSWORTH

Type YB

F3-317

Profil droit de culasse nue
Right hand view of bare cylinder head

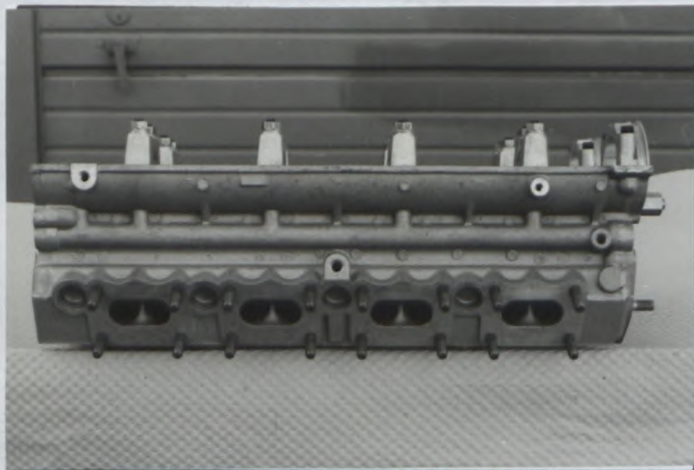

Profil gauche de culasse nue
Left hand view of bare cylinder head

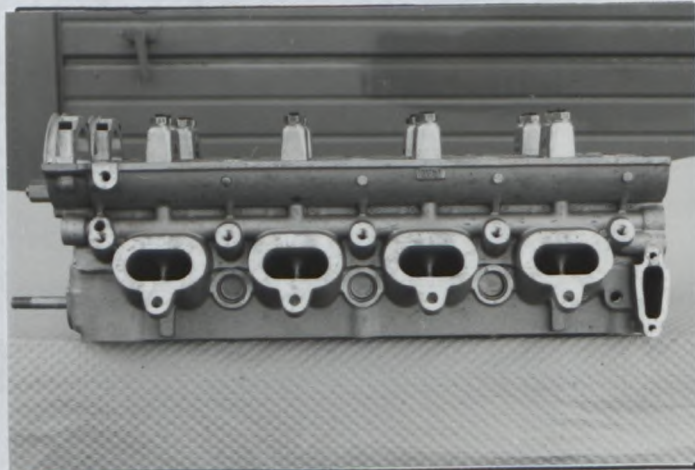

Bloc nu vu de dessus
Bare block seen from above

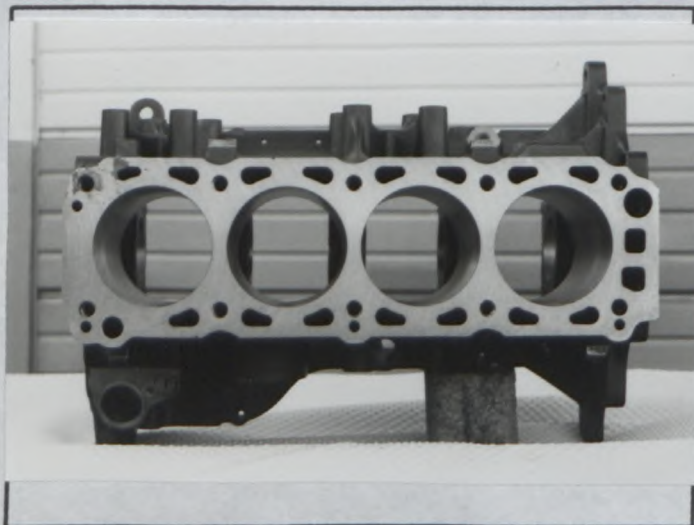

Bloc nu vu de dessous
Bare block seen from below

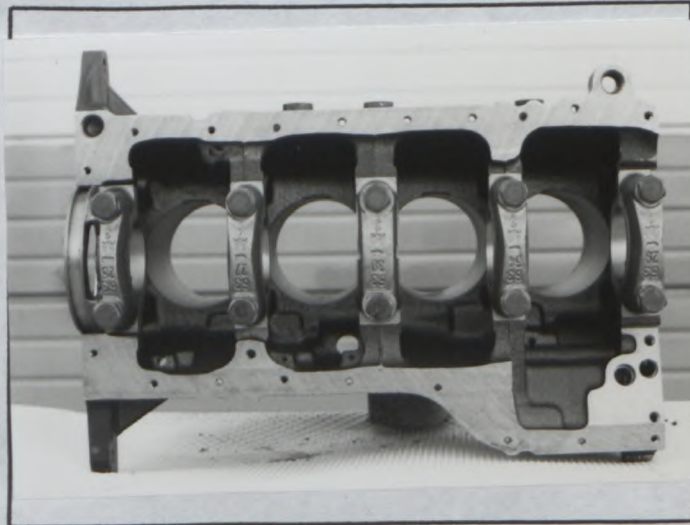

Profil droit du bloc nu
Right hand view of bare block

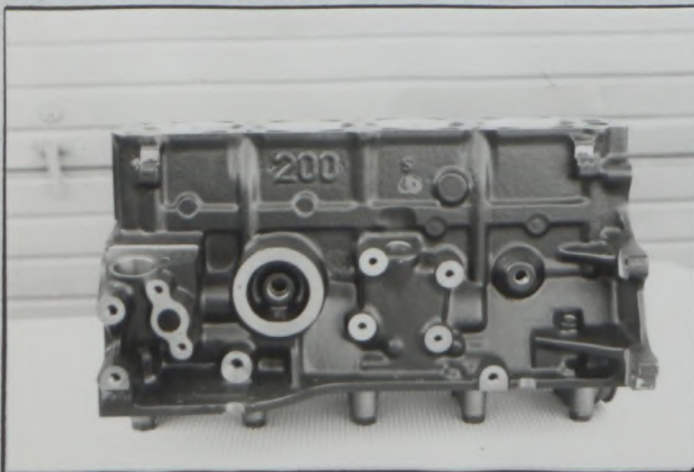

Profil gauche du bloc nu
Left hand view of bare block

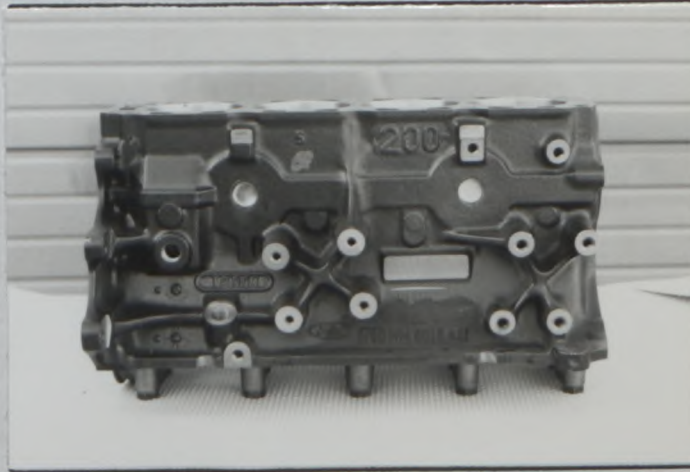

Q RSA - FC - 1990 - 002.02.FB.11.90

FEDERATION INTERNATIONALE
DE L'AUTOMOBILE
8, Place de la Concorde, 8
75008 PARIS