



F.I.A. Recognition No. 1664
Group TWO

ROYAL AUTOMOBILE CLUB

31, Belgrave Square, London, S.W.1

Form of recognition in accordance with appendix J to the International Sporting Code of the
FEDERATION INTERNATIONALE DE L'AUTOMOBILE

| | | | | | | |
|------------------------------------------------------------------------------|-----------------|-------------------|----------------------------------------------------------|------------------|-------|------------------|
| Manufacturer | BRITISH LEYLAND | Cylinder-capacity | 1798 | cm. ³ | 109.8 | in. ³ |
| Serial No. of chassis/body | AH 2DDE | Model | MARINA | | | |
| Serial No. of engine | 18V 776 | Manufacturer | AUSTIN | | | |
| Recognition is valid from | 1 OCTOBER 1974 | Manufacturer | AUSTIN | | | |
| | | List | | | | |
| The manufacturing of the model described in this recognition form started on | | 1st JUNE | 19 | 74 | | |
| and the minimum production of | | 1000 | identical cars, in accordance with the specifications of | | | |
| this form was reached on | | 5th JULY | 19 | 74 | | |

Photograph A. ¼ view of car from front

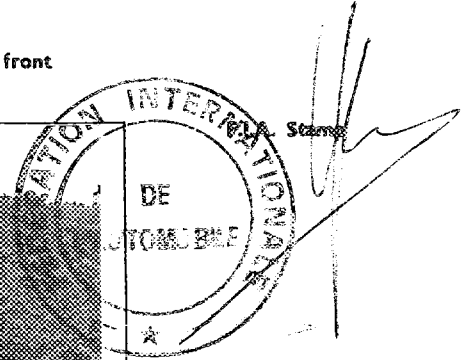

R.A.C. Stamp

B



C

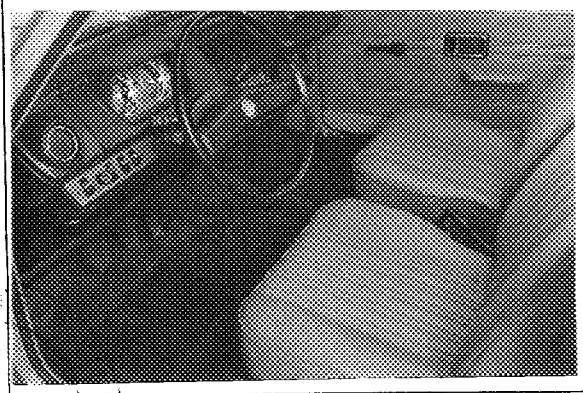

D

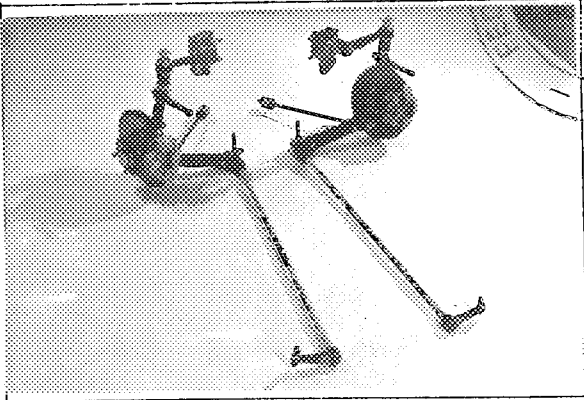

E

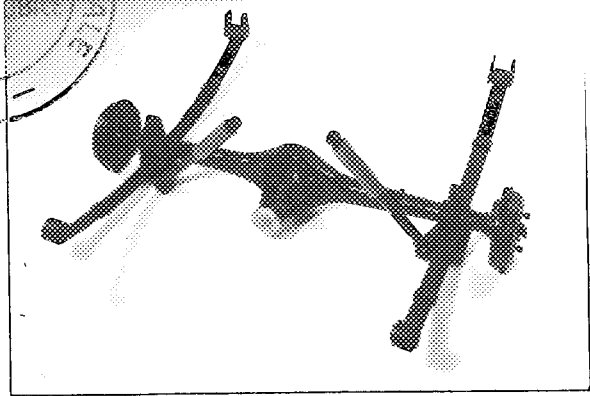

F

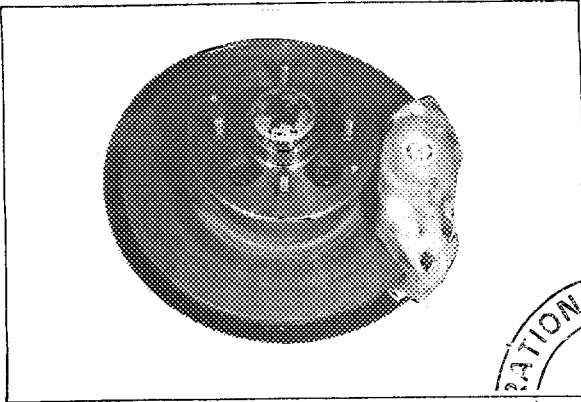

G

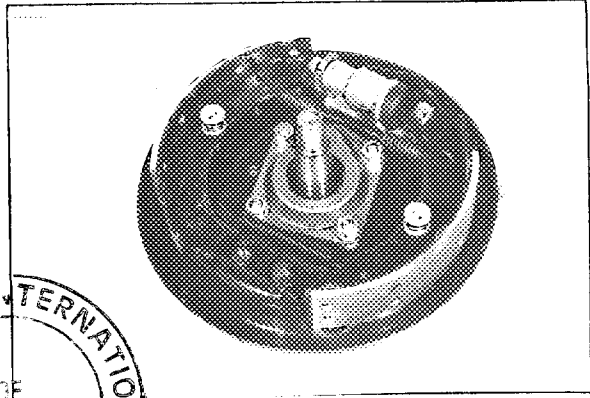

H

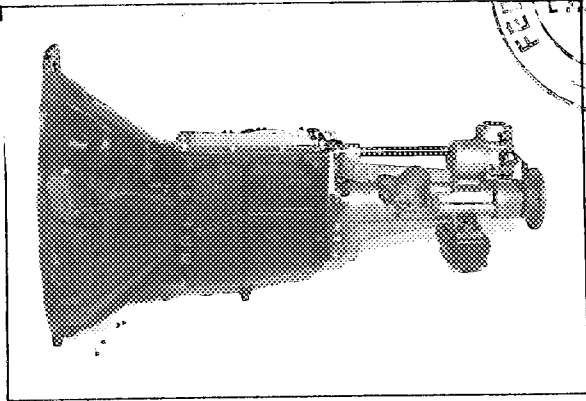

I

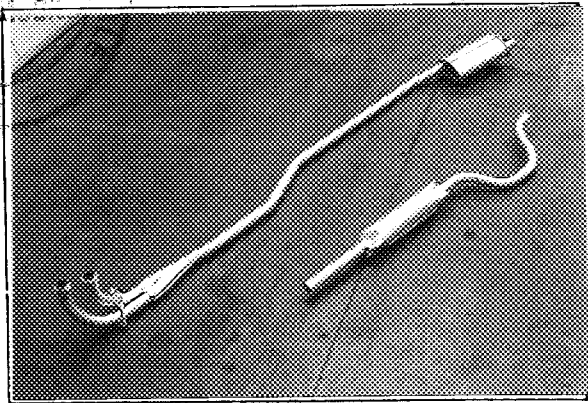

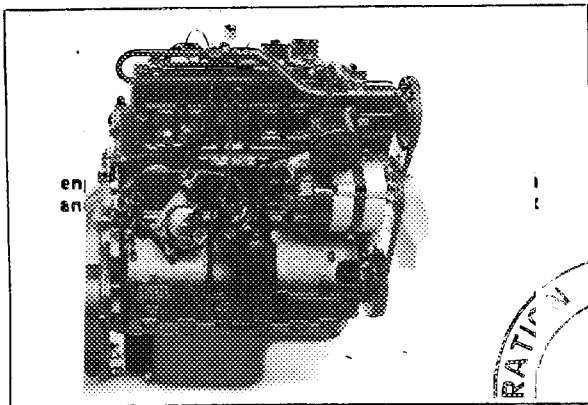

J en
an

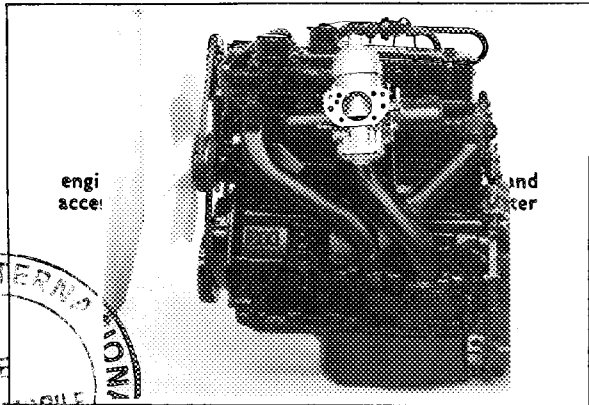

K engi
acce

and
ter

K

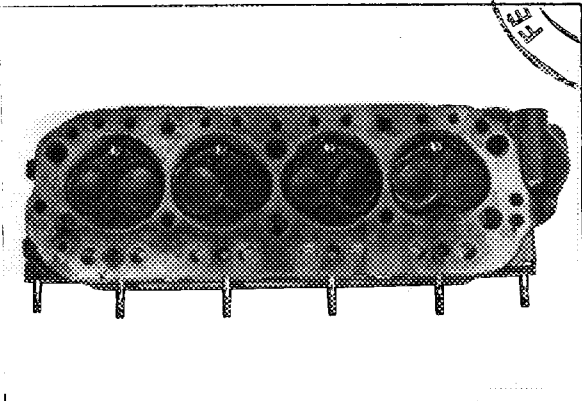
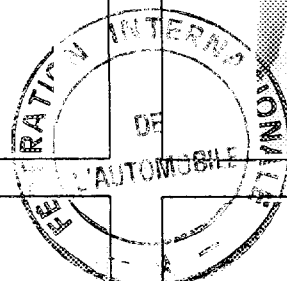

L

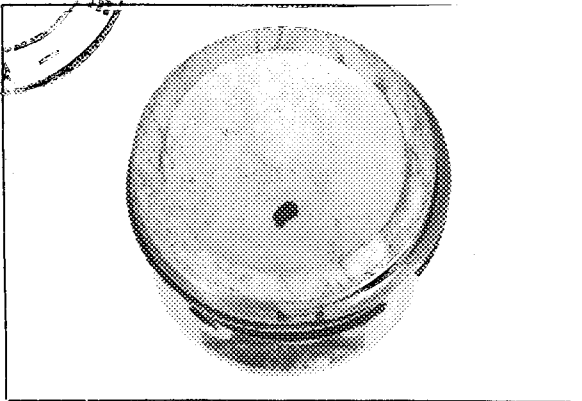

M

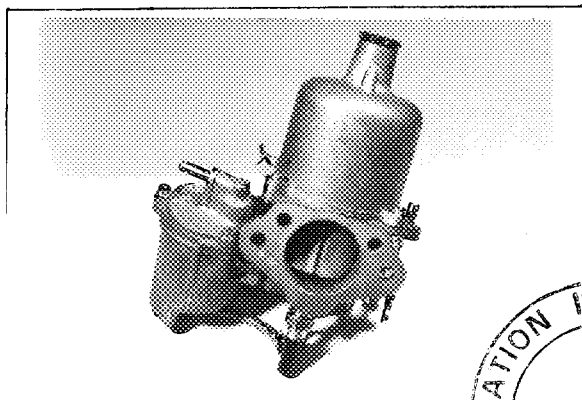

N

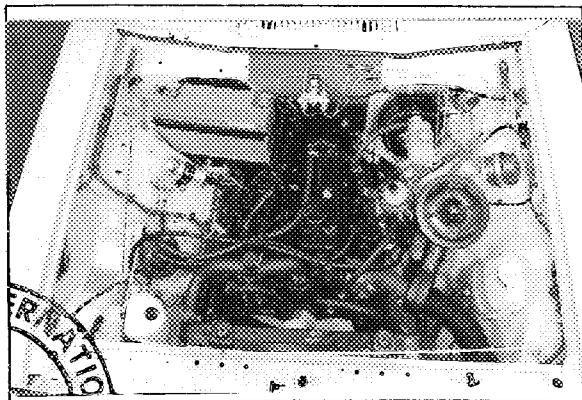

O

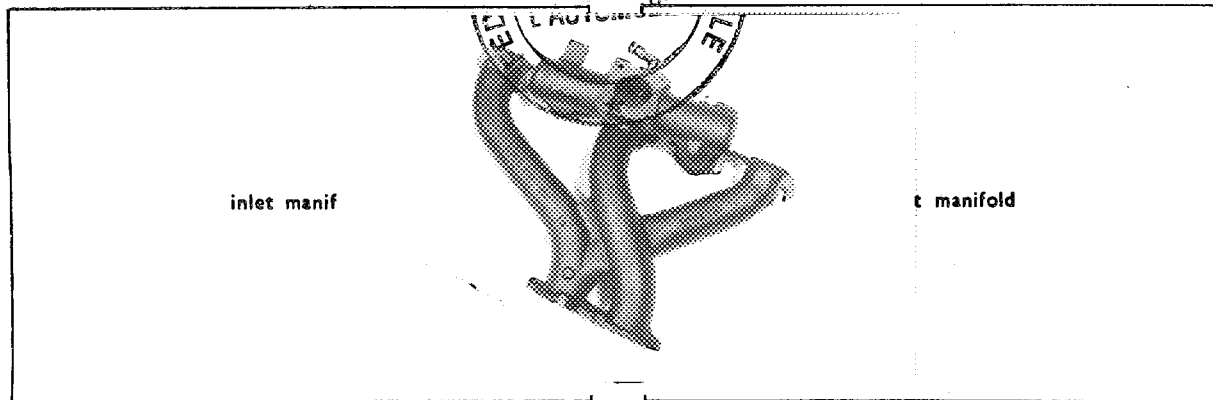
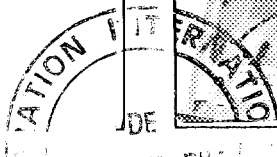

P inlet manif

Q t manifold

Q

Drawing inlet manifold ports, side of cylinderhead. Indicate scale or dimensions and manufacturing tolerance.

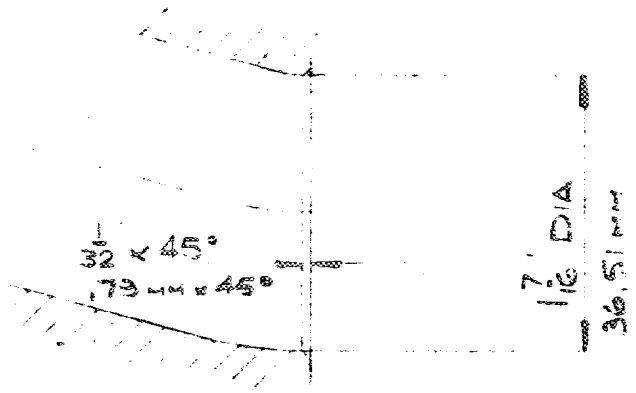

Drawing of entrance to inlet port of cylinderhead. Indicate scale or dimensions and manufacturing tolerance.

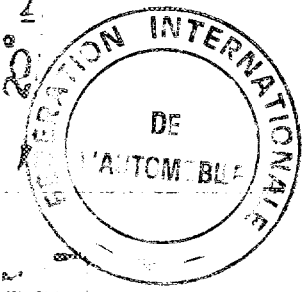
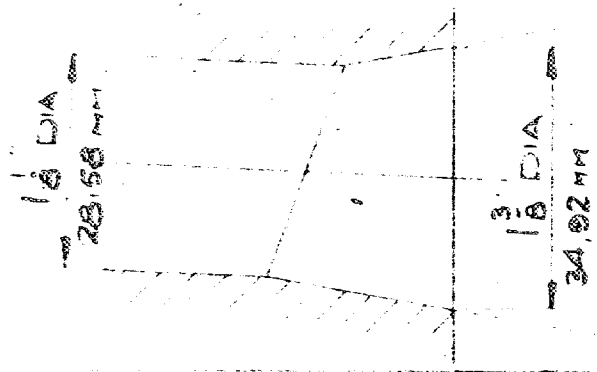

Drawing of exhaust manifold ports, side of cylinderhead. Indicate scale or dimensions and manufacturing tolerance.

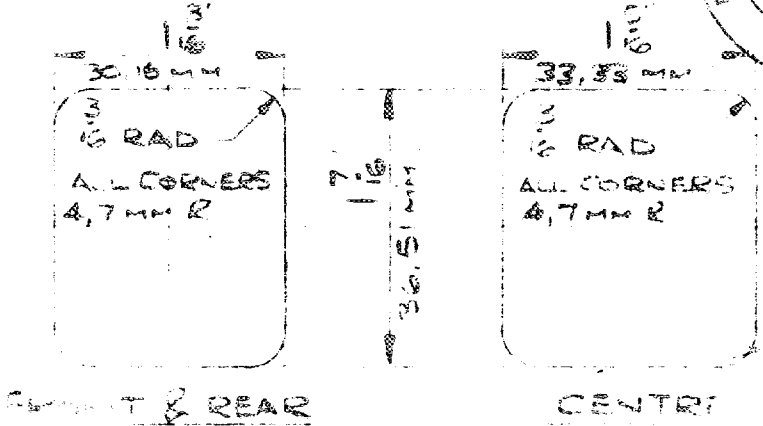

Drawing of exit to exhaust port of cylinderhead. Indicate scale or dimensions and manufacturing tolerance.

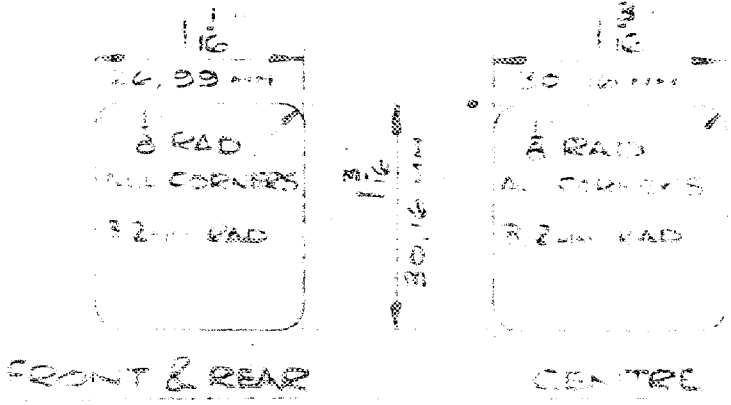

GENERAL DIMENSIONS

NOTE 1.

All dimensions must be given in two measuring systems, see Note 3.

CAPACITIES AND DIMENSIONS

| | | | | |
|----------------|--------|-----|----|--------|
| 1. Wheelbase | 2438.4 | mm. | 96 | inches |
| 2. Front track | 1320.8 | mm. | 52 | inches |
| 3. Rear track | 1320.8 | mm. | 52 | inches |

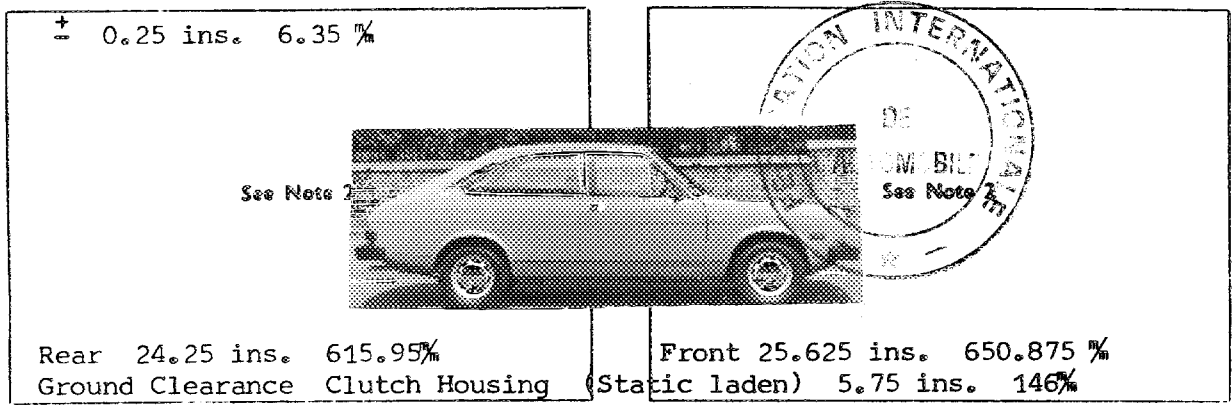

| | | | | |
|--------------------------------------------------------------------------------------------------------------------------|--------------|-------------|------------------|------------|
| 4. Overall length of the car | 419.1 | cm. | 165 | inches |
| 5. Overall width of the car | 175.2 | cm. | 69 | inches |
| 6. Width of car at Front & Rear axles | Front 164c/m | 64.625 ins. | Rear 167.957c/m. | 125 ins. |
| 7. Capacity of fuel tank (reserve included) | 52.279 | ltrs. | 13.2 | gall. U.S. |
| | | | 11.5 | gall. Imp. |
| 8. Seating Capacity. | 4 | | | |
| 9. Weight. Total weight of the car with normal equipment, water, oil, and spare wheel but without fuel or repair tools : | 883.9 | kg. | 1969 | lbs. |
| | | | 17.5 | cwts. |

NOTE 2.

Differences in track caused by the use of other wheels with different rim widths must be stated when recognition is requested for the wheels concerned. Specify ground clearance in relation to the track and give drawing of two easily recognisable points at front and rear at which measurements are taken. These ground clearance dimensions are only for information when checking the track and can in no way affect the eligibility of the car.

NOTE 3.

CONVERSION TABLE

| | | | | | |
|-------------------------|-----------|------------------|-------------------------|----------|-------|
| 1 inch/pouce | — 2.54 | cm. | 1 quart US | — 0.9464 | ltrs. |
| 1 foot/pied | — 30.4774 | cm. | 1 pint (pt) | — 0.568 | ltrs. |
| 1 sq. inch/pouce carre | — 6.452 | cm. ² | 1 gallon Imp. | — 4.546 | ltrs. |
| 1 cubic inch/pouce cube | — 16.387 | cm. ³ | 1 gallon US | — 3.785 | ltrs. |
| 1 pound/livre (lb) | — 453.593 | gr. | 1 hundred weight (cwt.) | — 50.802 | kg. |

CHASSIS AND COACHWORK (Photographs A, B and C)

- 20. Chassis/body construction: ~~SEPARATE~~/unitary construction
- 21. Unitary construction, material(s) STEEL
- 22. Separate construction, Material(s) of chassis -
- 23. Material(s) of coachwork STEEL
- 24. Number of doors 2 Material(s) STEEL
- 25. Material(s) of bonnet STEEL
- 26. Material(s) of boot lid STEEL
- 27. Material(s) of rear-window SAFETY GLASS
- 28. Material(s) of windscreen TOUGHENED/LAMINATED GLASS
- 29. Material(s) of front-door windows SAFETY GLASS
- 30. Material(s) of rear-door windows SAFETY GLASS
- 31. Sliding system of door windows VERTICAL WINDING
- 32. Material(s) of rear-quarter light SAFETY GLASS

ACCESSORIES AND UPHOLSTERY

- 38. Interior heating : yes — ~~no~~
- 39. Air conditioning : yes — ~~no~~ OPTIONAL
- 40. Ventilation : yes — ~~no~~
- 41. Front seats, type of seat and upholstery RECLINING BRUSH NYLON
- 42. Weight of front seat(s), complete with supports and rails, out of the car :

| | | | |
|-------|-----|------|------|
| 10.79 | kg. | 23.8 | lbs. |
|-------|-----|------|------|
- 43. Rear seats, type of seat and upholstery BENCH — BRUSH NYLON
RUBBER MOULDED
- 44. Front bumper, material(s) Steel Tube Weight 23.13 kg. 51 lbs.
Mountings
- 45. Rear bumper, material(s) Rubber Weight 23.13 kg. 51 lbs.
Moulded
Steel Tube mountings

WHEELS

- 50. Type PRESSED STEEL
- 51. Weight (per wheel, without tyre) 5.775 kg. 12.75 lbs.
- 52. Method of attachment 4 STUDS/NUTS
- 53. Rim diameter 330.2 mm. 13 ins.
- 54. Rim width 114.3 mm. 4.5 ins.

STEERING

- 60. Type RACK/PINION
- 61. Servo-assistance : ~~yes~~— no
- 62. Number of turns of steering wheel from lock to lock 3.98
- 63. In case of servo-assistance -

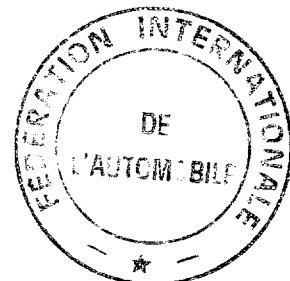

SUSPENSION

- 70. Front suspension (photograph D), type **INDEPENDENT**
- 71. Type of spring **TORSION BAR**
- 72. Stabiliser (if fitted) **-**
- 73. Number of shock absorbers **2** 74. Type **LEVER**
- 78. Rear suspension (photograph E), type **ELLIPTIC**
- 79. Type of spring **LEAF**
- 80. Stabiliser (if fitted) **-**
- 81. Number of shock absorbers **2** 82. Type **TELESCOPIC**

BRAKES (photographs F and G)

- 90. Method of operation **HYDRAULIC**
- 91. Servo-assistance (if fitted), type **DIRECT ACTING**
- 92. Number of hydraulic master cylinders **DUAL**

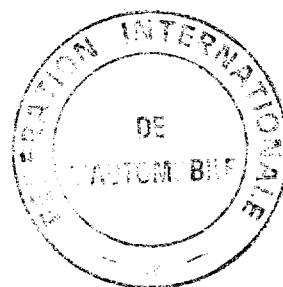

- 93. Number of cylinders per wheel **2** **FRONT** **1** **REAR**
- 94. Bore of wheel cylinder(s) mm. inches 17.78 mm. 0.7 inches

Drum Brakes

- 95. Inside diameter mm. inches 203.2 mm. 8 inches
- 96. Length of brake linings mm. inches 203.2 mm. 8 inches
- 97. Width of brake linings mm. inches 38.1 mm. 1.5 inches
- 98. Number of shoes per brake **2**
- 99. Total area per brake mm.² sq. in. 490.2 mm.² 76 sq. in.

Disc Brakes

- 100. Outside diameter 248.5 mm. 9.785 inches mm. inches
- 101. Thickness of disc 9.525 mm. 0.375 inches mm. inches
- 102. Length of brake linings 60.325 mm. 2.375 inches mm. inches
- 103. Width of brake linings 47.625 mm. 1.875 inches mm. inches
- 104. Number of pads per brake **2**
- 105. Total area per brake 2671 mm.² 182.8 sq. in. mm.² sq. in.

| | | | |
|-----------------------------------------------------------------------------|------------------------|-----------------------------------------|----------------------------------------------|
| 130. Cycle | 4 STROKE | 131. Number of cylinders | 4 |
| 132. Cylinder Arrangement | IN LINE | | |
| 133. Bore | 80.26 mm. | 134. Stroke | 89 mm. 3.5 in. |
| 135. Capacity per cylinder | | | 449.5 cm. ³ 27.45 cu. in. |
| 136. Total cylinder capacity | | | 1798 cm. ³ 109.8 cu. in. |
| 137. Material(s) of cylinder block | CAST IRON | 138. Material(s) of sleeves (if fitted) | - |
| 139. Cylinder head, material(s) | CAST IRON | Number fitted | 1 |
| 140. Number of inlet ports | 2 | 141. Number of exhaust ports | 3 |
| 142. Compression ratio | 8.0:1 | | |
| 143. Volume of one combustion chamber | | | 56.2 cm. ³ 3.4 cu. in. |
| 144. Piston, material | ALUMINIUM | 145. Number of rings | 3 |
| 146. Distance from gudgeon pin centre line to highest point of piston crown | | | ± 0.5% 42.11 mm. 1.65 in. |
| 147. Crankshaft: rounded /stamped | | 148. Type of crankshaft: integral/ | YES |
| 149. Number of crankshaft main bearings | 5 | | |
| 150. Material of bearing cap | CAST IRON | | |
| 151. System of lubrication: dry sump /oil in sump | | | |
| 152. Capacity, lubricant | 4.54 ltrs. 8 pts. | | quarts U.S. |
| 153. Oil cooler: yes /no | | 154. Method of engine cooling | PRESURISED RADIATOR |
| 155. Capacity of cooling system | 4.54 ltrs. 9 pts. | | quarts U.S. |
| 156. Cooling fan (if fitted) dia. | | | 30.48 cm. 12 in. |
| 157. Number of blades of cooling fan | 7 | | |
| <u>Bearings</u> (insert tolerances) | | | |
| 158. Crankshaft main, type | STEEL BACK COPPER LEAD | dia. | 54.02 m.m. 2.127 in.) + |
| 159. Connecting rod big end, type | STEEL BACK COPPER LEAD | dia. | 47.66 m.m. 1.876 in.) 0.2% |
| <u>Weights</u> (insert tolerances) | | | |
| 160. Flywheel (clean) | | | 9.619 kg. 21 lbs.) |
| 161. Flywheel with clutch (all turning parts) | | | 15.464 kg. 34 lbs.) + 7% |
| 162. Crankshaft | 16.3 kg. 36 lbs. | 163. Connecting rod | 0.906 kg. 2 lbs.) |
| 164. Piston with rings and pin | | | 0.502 kg. 11b. 1oz. lbs.) - 3% |
| 254. Reboring dimensions | .0000 | 255. Total resultant cylinder capacity | 1798 cm. ³ 109.8 cu. in. |
| 256. Volume of the combustion chamber in the head | | | 38 - 39 cm. ³ 2.32 - 2.38 cu. in. |
| 257. Thickness of the head gasket after tightening | mm. in. | | |
| | .1058 8 | | .041 |

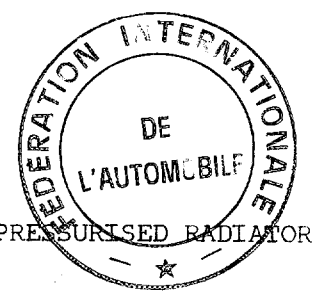

FOUR STROKE ENGINES

170. Number of camshafts 1 171. Location CYLINDER BLOCK
 172. Type of camshaft drive ROLLER CHAIN
 173. Type of valve operation O.H.V. PUSH ROD AND ROCKER

INLET (see page 4)*

180. Material(s) of inlet manifold CAST IRON 41.275/ 1.625/
 181. Diameter of valves 41.40 mm. 1.630 ins.
 182. Max. valve lift 9.14 mm. 0.360 in.+1% 183. Number of valve springs 1
 184. Type of spring COIL 185. Number of valves per cylinder 1
 186. Tappet clearance for checking timing (cold/warm) 0.51 mm. 0.020 ins.
 187. Valves open at (with tolerance for tappet clearance indicated) 16° B.T.D.C.
 188. Valves close at (with tolerance for tappet clearance indicated) 56° A.B.D.C.
 189. Air filter, type PAPER ELEMENT

EXHAUST (see page 4)*

195. Material(s) of exhaust manifold CAST IRON 33.11/ 1.343/
 196. Diameter of valves 34.23 mm. 1.348 ins.
 197. Max. valve lift 9.14 mm. 0.360 in.+1% 198. Number of valve springs 1
 199. Type of spring COIL 200. Number of valves per cylinder 1
 201. Tappet clearance for checking timing (cold/warm) 0.51 mm. 0.020 ins.
 202. Valves open at (with tolerance for tappet clearance indicated) 51° B.B.D.C.
 203. Valves close at (with tolerance for tappet clearance indicated) 21° A.T.D.C.
 204. Diameter outlet orifice exhaust manifold 39.7 mm. 1.56 ins.

CARBURETION (photograph N)

210. Number of carburettors fitted 1 211. Type VARIABLE CHOKE
 212. Make S.U. 213. Model H.I.F. 6
 214. Number of mixture passages per carburettor 1
 215. Flange hole diameter of exit port(s) of carburettor 44.5 mm. 1.75 ins. +0.2%
 216. Minimum diameter of venturi/minimum diam. with piston at maximum height (example : SU)
 34.11 mm. 1.343 ins.

INJECTION (if fitted)

NOT FITTED

220. Make of pump 221. Number of plungers
 222. Model or type of pump 223. Total number of injectors
 224. Location of injectors
 225. Minimum diameter of inlet pipe

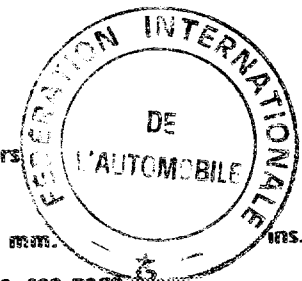

* For additional information concerning two-stroke engines and super-charged engines, see page 13.

ENGINE ACCESSORIES

- | | | |
|--------------------------------------------------------------------|----------------|--------------------------------------|
| 230. Fuel pump : mechanical and/or electrical | | MECHANICAL |
| 231. No. fitted | 1 | |
| 232. Type of ignition system | H.T. COIL | 233. No. of distributors |
| | | 1 |
| 234. No. of ignition coils | 1 | 235. No. of spark plugs per cylinder |
| | | 1 |
| 236. Generator, type : dynamo /alternator—number fitted | 1 | |
| 237. Method of drive | BELT | |
| 238. Voltage of generator | 12 | volts |
| 239. Battery, number | 1 | |
| 240. Location | BENEATH BONNET | |
| 241. Voltage of battery | 12 | volts |
| 242. Volume of one Combustion Chamber | 38/39cc | 2.32/ 2.38 cu.in. |

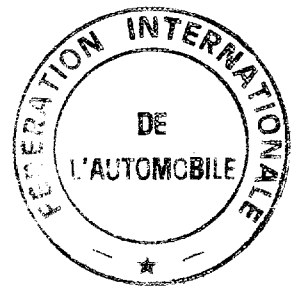

ENGINE AND CAR PERFORMANCES (as declared by manufacturer in catalogue)

- | | | | | |
|----------------------------|---------------------------------------|-------------------------------------|------------|--------|
| 250. Max. engine output | 77 | (type of horsepower: SAE J 245) at | 5250 | r.p.m. |
| 251. Max. r.p.m. | 6200 | output at that figure | | |
| 252. Max. torque | | 91.5 lb.ft at | 3.100 | r.p.m. |
| 253. Max. speed of the car | | km./hour | miles/hour | |
| | NOT QUOTED IN MANUFACTURERS CATALOGUE | | | |

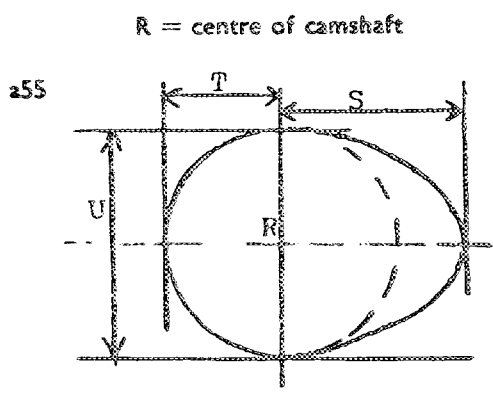

| | | | |
|--------------------|-------|-----|--------------|
| <u>Inlet cam</u> | | | |
| S = | 20.95 | mm. | 0.825 inches |
| T = | 14.17 | mm. | 0.558 inches |
| U = | 28.24 | mm. | 1.112 inches |
| <u>Exhaust cam</u> | | | |
| S = | 20.95 | mm. | 0.825 inches |
| T = | 14.17 | mm. | 0.558 inches |
| U = | 28.24 | mm. | 1.112 inches |

DRIVE TRAIN

CLUTCH

260. Type of clutch DIAPHRAGM SPRING
261. No. of plates 1
262. Dia. of clutch plates 20.32 cm 8 ins.
263. Dia. of linings, inside 14.47 cm 5.7 ins.
- outside 20.32 cm 8 ins.
264. Method of operating clutch HYDRAULIC

GEAR BOX (photograph H)

270. Manual type, make B.L.M.C. Method of operation LEVER
271. No. of gear-box ratios forward 4 272. Synchronized forward ratios 4
273. Location of gear-shift FLOOR
274. Automatic, make BORG WARNER type 35
275. No. of forward ratios 3 276. Location of gear shift FLOOR

| 277. | Manual | | Automatic | | Alternative manual/automatic | | | |
|---------|--------|--------------------------------------|-----------|-----------|------------------------------|-----------|-------|-----------|
| | Ratio | No. teeth | Ratio | No. teeth | Ratio | No. teeth | Ratio | No. teeth |
| 1 | 3.111 | $\frac{28}{18} \times \frac{30}{15}$ | 2.39 | | | | | |
| 2 | 1.926 | $\frac{28}{18} \times \frac{26}{21}$ | 1.45 | | | | | |
| 3 | 1.307 | $\frac{28}{18} \times \frac{21}{25}$ | 1.00 | | | | | |
| 4 | 1.000 | Direct | | | | | | |
| 5 | | | | | | | | |
| 6 | | | | | | | | |
| reverse | 3.422 | | 2.09 | | | | | |

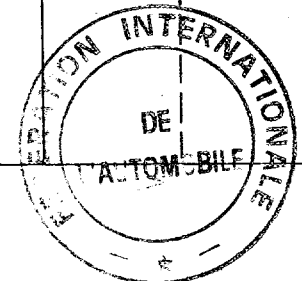

278. Overdrive, type -
279. Forward gears on which overdrive can be selected -
280. Overdrive ratio -

FINAL DRIVE

290. Type of final drive HYPOID BEVEL GEAR 291. Type of differential CROWN WHEEL & PINION
292. Type of limited slip differential (if fitted in series-production) -
293. Final drive ratio 3.636:1 Number of teeth 11 x 40
- Optional 4.111:1 9 x 37

IMPORTANT:

During the scrutineering of cars entered in group 5 (Sportscars) only the following items of the present recognition form are to be taken into consideration: 1, 2, 3, 9, 20, 21, 22, 23, 24, 25, 26, 70, 71, 78, 79, 90, 130, 131, 132, 133, 134, 135, 136, 137, 138, 139, 140, 141, 147, 148, 149, 150, 158, 159, 170, 171, 172, 173, 185, 200, 270, 271, 274, 275, 290, 291, 292 and photographs A, B, D, E, F, G, H, J, K and O.

The vehicle described in this form has been subject to the following amendments:

| | | | | | | | |
|---------|---------|--------------|-----------|---------|---------|--------------|-----------|
| on..... | 19..... | rec. no..... | List..... | on..... | 19..... | rec. no..... | List..... |
| on..... | 19..... | rec. no..... | List..... | on..... | 19..... | rec. no..... | List..... |
| on..... | 19..... | rec. no..... | List..... | on..... | 19..... | rec. no..... | List..... |
| on..... | 19..... | rec. no..... | List..... | on..... | 19..... | rec. no..... | List..... |
| on..... | 19..... | rec. no..... | List..... | on..... | 19..... | rec. no..... | List..... |

Optional equipment affecting preceding information. This to be stated together with reference number.

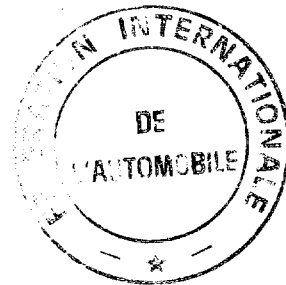



MOTOR SPORT DIVISION
The Royal Automobile Club
 31 Belgrave Square, London SW1X 8QH

Manufacturer BRITISH LEYLAND
 Model AUSTIN MARINA
 F.I.A. Recognition No. 1664
 Amendment No. 1/IV

Amendment to Form of Recognition

FEDERATION INTERNATIONALE DE L'AUTOMOBILE

VALID IN GROUP TWO - VARIANT

- | | | |
|-----|---------------------------------------------------------------------|------------------------------------|
| No. | Reference No. | |
| 1. | HEAVY DUTY REAR AXLE. PART NO. C-AJJ 4080 | |
| | 290. TYPE OF FINAL DRIVE - HYPOID BEVEL GEARS | |
| | 291. TYPE OF DIFFERENTIAL - CROWN WHEEL & PINION | |
| | 292. TYPE OF LIMITED SLIP DIFFERENTIAL - NO SPIN PART NO. C-AHT 547 | |
| | 293. FINAL DRIVE RATIO 4.3:1 NUMBER OF TEETH 10 x 43 | |
| | <u>BRAKES</u> | |
| | 93. NUMBER OF CYLINDERS PER WHEEL | 1 |
| | 94. BORE OF WHEEL CYLINDER | 0.875 ins. 22.22% |
| | 95. INSIDE DIAMETER | 9 ins 228.6% |
| | 96. LENGTH OF BRAKE LINING | 8.75 ins 222.25% |
| | 97. WIDTH OF BRAKE LINING | 1.75 ins 44.45% |
| | 98. NUMBER OF SHOES PER BRAKE | 2 |
| | 99. TOTAL AREA PER BRAKE | 61.250 sq.ins. 9869 % ² |
| 2. | CRANKSHAFT NITRIDED PART NO. C-AEH 822 | |
| | 147. CRANKSHAFT STAMPED STEEL | |
| | 149. NUMBER OF CRANKSHAFT MAIN BEARINGS | 5 |
| | <u>BEARINGS</u> | |
| | 158. CRANKSHAFT MAIN TYPE STEEL BACK COPPER LEAD | 54.02% 2.127 ins |
| | 159. CONNECTING ROD BIG END TYPE STEEL BACK COPPER LEAD | 47.66% 1.876ins |
| | <u>WEIGHT</u> | |
| | 162. CRANKSHAFT | 15.875 kg. 35 lbs. |
| 3. | FRONT HUB PART NUMBER C-AHT 519 | |
| 4. | SUMP GUARD PART NUMBER C-AJJ 4086 | 54" x 27" 42lbs weight - 19.05Kg |
| 5. | PETROL TANK SHIELD C-AHT 529 | 29" x 18" 711 x 736 mm |

"valable en Groupe 2 uniquement"
 "valid for Group 2 only"

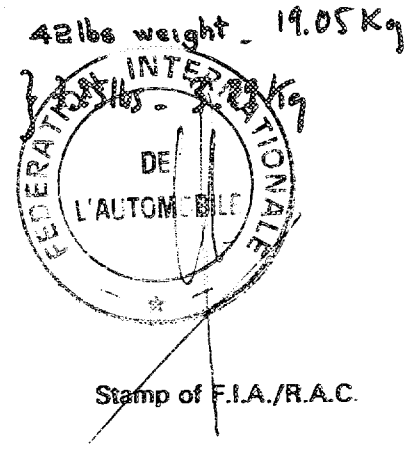

Date amendment is valid from 1.10.76

Stamp of F.I.A./R.A.C.



MOTOR SPORT DIVISION
The Royal Automobile Club
 31 Belgrave Square, London SW1X 8QH

Manufacturer BRITISH LEYLAND
 Model AUSTIN MARINA
 F.I.A. Recognition No. 1664
 Amendment No. 1/IV

Amendment to Form of Recognition

FEDERATION INTERNATIONALE DE L'AUTOMOBILE

Photographs must be 3" x 2" and a matt finish

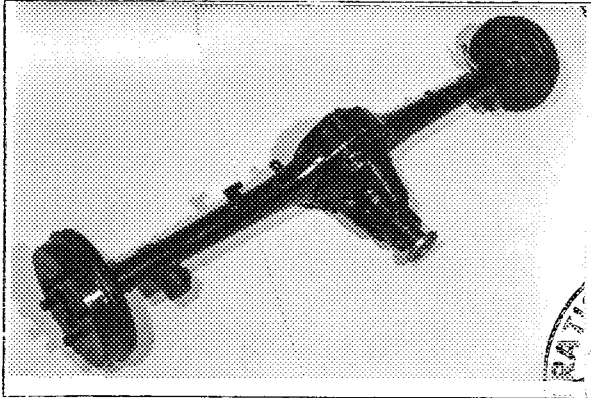

1. HEAVY DUTY REAR AXLE

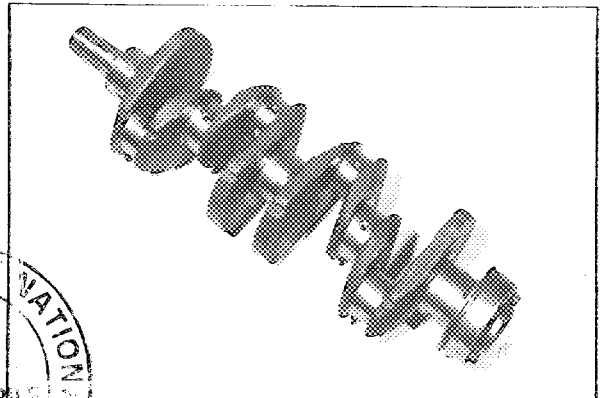

2. CRANKSHAFT

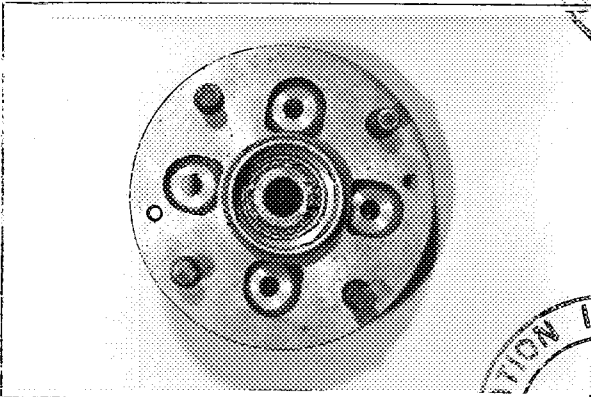

3. FRONT HUB

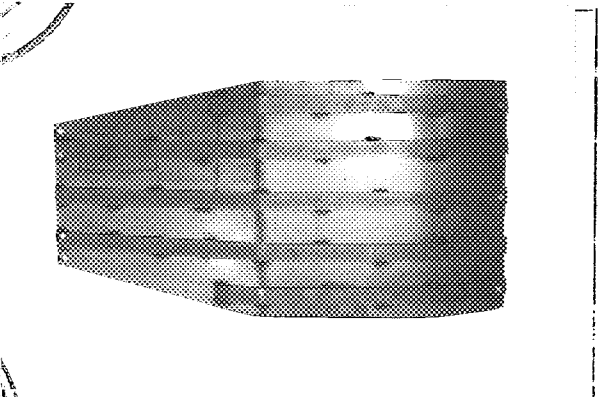

SUMP GUARD

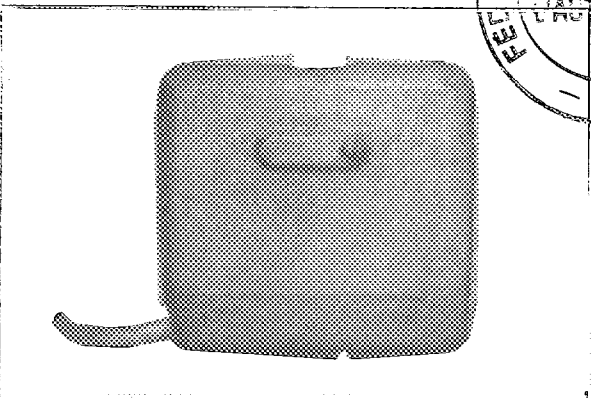

4. PETROL TANK SHIELD

"valable en Groupe 2 uniquement"
 "valid for Group 2 only"

Date amendment is valid from.....

Stamp of F.I.A./R.A.C.



AUSTIN - MARINA

MARQUE ET MODELE

10/74

VALIDITE HOMOLOGATION

1654

FICHE NR.

2 / 2000

GROUPE / CLASSE

| EXTENSIONS | DEBUT VALIDITE | DESCRIPTION | NOTES |
|------------|----------------|-------------------------------------------------------------------|-------|
| R/V | 20/74 | AXE AR - FREIN - VILLEBRIQUIN - PALIER - NOUVEAU - PROTECTIONS | |
| | | | |
| | | | |
| | | | |
| | | | |
| | | | |
| | | | |
| | | | |
| | | | |
| | | | |
| | | | |
| | | | |
| | | | |
| | | | |
| | | | |
| | | | |
| | | | |
| | | | |
| | | | |
| | | | |

Autres homologations du modèle

Vérifiée le 25/10/95 par [Signature] visée ce jour le _____ par _____