

FÉDÉRATION INTERNATIONALE DE L'AUTOMOBILE

FICHE D'HOMOLOGATION CONFORME A L'ANNEXE J DU CODE SPORTIF INTERNATIONAL
POUR LES VOITURES DES GROUPES 1 A 5

BOOK OF RECOGNITION IN ACCORDANCE WITH APPENDIX J TO THE INTERNATIONAL
SPORTING CODE FOR CARS OF GROUPS 1 TO 5

Constructeur/Manufacturer SAAB-SCANIA AB Modèle / Model SAAB 99 TURBO

Cylindrée / Cylinder capacity 1985 (2780)

Constructeur du châssis / Chassis Manufacturer SAAB-SCANIA AB

Constructeur du moteur / Engine Manufacturer SAAB-SCANIA AB

Homologation valable à partir du / Recognition valid as from 1 JANUARY 1978

Modèle homologué en groupe 4
Model recognized in group

Numéro d'homologation
Recognition number 652

Photo A : voiture vue de 3/4 AV
Photo A : 3/4 view of car from front

Photo B : voiture vue de 3/4 AR
Photo B : 3/4 view of car from rear

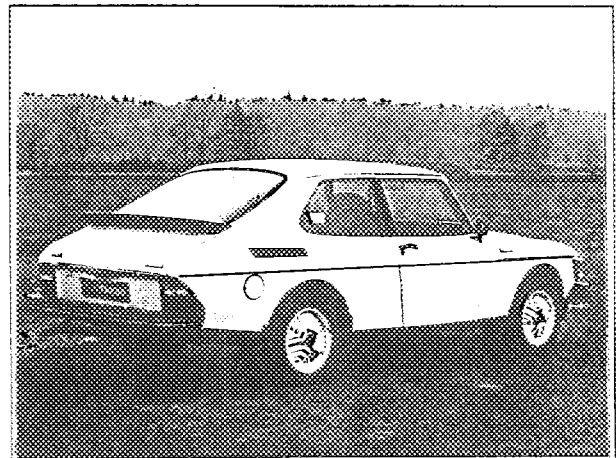
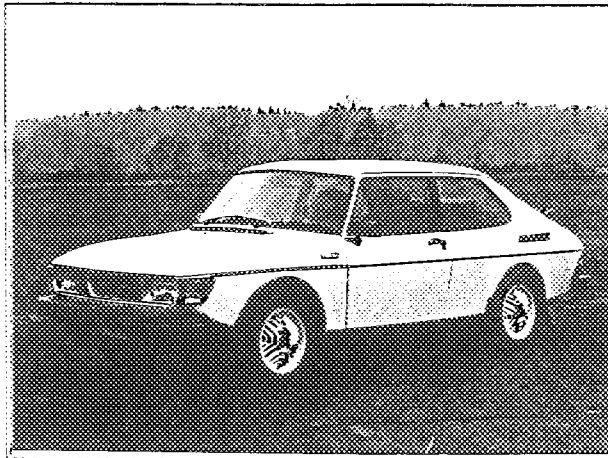

CARACTÉRISTIQUES GÉNÉRALES / GENERAL CHARACTERISTICS :

- 1) Mode de construction : construction séparée / monocoque.
Type of car construction : separate / unitary construction.
- 2) Matériau du châssis Steel Matériau de la carrosserie Steel
Material of chassis Material of coachwork
- 3) Empattement droit 2473 mm Gauche 2473 mm
Wheelbase right Left
- 4) Largeur de la carrosserie mesurée aux axes AV 1650 mm
Width of bodywork measured at front axle
- 5) Largeur de la carrosserie mesurée aux axes AR 1690 mm
Width of bodywork measured at rear axle
- 6) Longueur hors-tout avec pare-chocs 4530 mm Sans pare-chocs 4340 mm
Overall length with bumpers Without bumpers
- 7) Type de suspension : AV Independent AR Rigid axle with trailing arms
Type of suspension : Front Rear

(Photo D)

(Photo E)

Signature et cachet de
l'autorité sportive nationale.

Signature et cachet
de la F.I.A.,

SVENSKA BILSPORTFÖRBUNDET
THE SWEDISH AUTOMOBILE SPORT FEDERATION

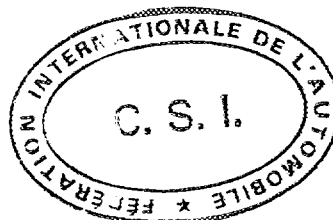

NOTA : Les pages 1 à 7 comportent toutes les indications nécessaires à la vérification technique pour les Groupes 2 et 4.
Pages 8 include necessary information for the scrutineering of cars for Groups 2 and 4.

Marque / Make SAAB Modèle / Model TURBO N° 652

MOTEUR :

- 8) Cycle 4-stroke
- 9) Nombre et disposition des cylindres 4 in line
Number and disposition of cylinders
- 10) Système de refroidissement Water cooling
Cooling system
- 11) Emplacement et position du moteur Front, in line
Location and position of engine
- 12) Matériau du bloc moteur Cast iron
Material of engine block
- 13) Roues motrices : AV - AR Front
Drive wheels : Front - Rear
- 14) Emplacement de la boîte de vitesses Below the engine in a compact unit
Location of gear-box

CARROSSERIE ET ÉQUIPEMENT INTÉRIEUR / COACHWORK AND INTERIOR

- 20) Nombre de portes 2 doors (1 rear gate)
Number of doors
- 21) Matériau des portes : AV Steel sheet AR
Material of doors : Front Steel sheet Rear
- 22) Matériau du capot moteur Steel sheet
Material of bonnet
- 23) Matériau du capot coffre Steel sheet
Material of boot lid
- 24) Matériau de la lunette AR Safety glass
Material of rear window
- 25) Matériau du pare-brise Laminated glass
Material of windscreen
- 26) Matériau des glaces des portières AV Safety glass
Material of front door windows
- 27) Matériau des glaces des portières AR -
Material of rear door windows
- 28) Système d'ouverture des vitres portières AV Wheel and lever mechanism AR -
Sliding system of door windows Front mechanical Rear
- 29) Matériau des glaces de custode Safety glass
Material of rear quarter lights
- 30) Poids siège (s) AV (enlevés de la voiture avec dossiers, glissières et supports) 15.5 kg
Weight of front seat(s) (complete with supports and rails, out of the car)
- 31) Matériau du pare-choc AV Aluminium, plastic, rubber Poids 12 kg
Front bumper material Weight
- 32) Matériau du pare-choc AR Aluminium, plastic, rubber Poids 11 kg
Rear bumper material Weight
- 33) Ventilation : oui non / yes no

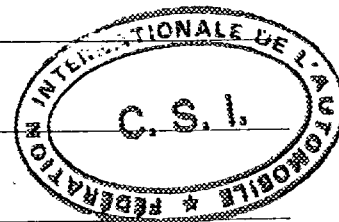

Marque / Make SAAB Modèle / Model TURBO N° 652

DIRECTION / STEERING

40) Type Rack and pinion
 41) Servo-assistance No

SUSPENSION

45) Suspension AV (photo D) Type de ressort Coil spring
 Front suspension (photo D) Type of spring
 46) Nombre d'amortisseurs 2
 Number of shock absorbers
 47) Suspension AR (Photo E) Type de ressort Coil spring
 Rear suspension (Photo E) Type of spring
 48) Nombre d'amortisseurs 2
 Number of shock absorbers
 49) Système de fixation des roues Bolt and nut
 Method of fixation of wheels

FREINS - BRAKES

50) Système Hydraulic
 Method of operation
 51) Servo frein (si prévu) Type : Vacuum
 Servo assistance (if fitted) Type :
 52) Nombre de maîtres-cylindres 1 tandem type
 Number of master-cylinders

	AVANT / FRONT	ARRIERE / REAR
53) Nombre de cylindres par roue Number of cylinders per wheel	2	2
54) Alésage Bore	54 mm	30 mm
Freins à tambour / Drum brakes		
55) Diamètre intérieur Inside diameter		
56) Nombre de mâchoires par frein Number of shoes per brake		
57) Surface de freinage par frein Total area per brake		
Freins à disques / Disc brakes		
58) Largeur des sabots Width of brake linings	52 mm	39 mm
59) Nombre de sabots par frein Number of pads per brake	2	2
60) Surface de freinage par frein Total area per brake	71 600 mm ²	54 750 mm ²

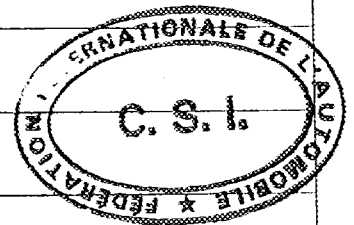

Marque / Make SAAB Modèle / Model TURBO N° 652

MOTEUR / ENGINE

- 65) Alésage 90 mm
Bore
- 67) Course 78 mm
Stroke
- 68) Cylindrée totale 1985 (2780) 69) Cylindrée maximum autorisée 2816
Total cylinder-capacity Maximum cylinder-capacity allowed
- 70) Culasse : matériau Aluminium 71) Nombre 1
Head : material Number
- 72) Type de vilebrequin Integral Coulé / estampé Stamped
Type of crankshaft Moulded / stamped
- 73) Nombre de paliers de vilebrequin 5
Number of crankshaft main bearings
- 74) Diamètre maximal des manetons de vilebrequin 52 mm
Maximum diameter of the big end journal
- 75) Tête de bielle : type Shell diamètre 52 mm
Connecting rod big end type
- 76) Matériau des chapeaux des paliers de vilebrequin Cast iron
Material of bearing cap
- 77) Matériau du volant moteur Steel
Material of flywheel
- 78) Matériau du vilebrequin Steel
Crankshaft material
- 79) Matériau de la bielle Steel
Connecting rod material
- 80) Système de graissage : carter sec - carter humide Oil in sump
Lubrication system : dry-sump - oil in sump
- 81) Nombre de pompes à huile 1
Number of oil pumps

Moteur 4 temps / 4 stroke engines

- 82) Nombre d'arbres à cames 1 Emplacement Overhead
Number of camshafts Location
- 83) Système de commande Chain
Type of camshaft drive
- 84) Système de commande des soupapes Cam to tappet
Type of valve operation
- 85) Nombre de soupapes d'admission par cylindre 1
Number of inlet valves per cylinder
- 86) Nombre de soupapes d'échappement par cylindre 1
Number of exhaust valves per cylinder
- 87) Nombre de distributeurs 1
Number of distributors
- 88) Nombre de bougies par cylindre 1
Number of spark plug per cylinder

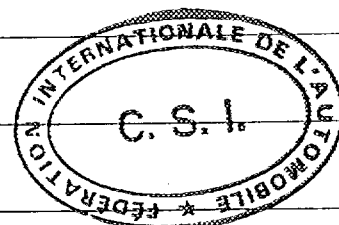

TRANSMISSION AUX ROUES / DRIVE TRAIN

Embrayage / Clutch

- 90) Nombre de disques 1
Number of plates
- 91) Système de commande Hydraulique
Method of operating clutch

Boîte de vitesses / Gear-box

- 92) Contrôle manuel, marque SAAB-SCANIA
Manual type, make
- 93) Nombre de rapports AV 4
Number of gear-box ratios forward
- 94) Boîte automatique, marque Borg-Warner
Automatic, make
- 95) Nombre de rapports AV 3
Number of gear-ratios forward

96	Manuelle / Manual		Automatique		Supp. manuel / Automatique			
	Rapport Ratio	N. dents Nr teeth	Rapport Ratio	N. dents Nr teeth	Rapport Ratio	N. dents Nr teeth	Rapport Ratio	N. dents Nr teeth
1	3.44	$\frac{33}{18} \cdot \frac{30}{16}$	2.39		2.20	$\frac{27}{23} \cdot \frac{30}{16}$		
2	2.07	$\frac{33}{18} \cdot \frac{26}{23}$	1.45		1.53	$\frac{27}{23} \cdot \frac{26}{20}$		
3	1.39	$\frac{33}{18} \cdot \frac{22}{29}$	1.00		1.22	$\frac{27}{23} \cdot \frac{25}{24}$		
4	1.00				1.00			
5								
6								
M. AR / Rev.	3.78	$\frac{33}{18} \cdot \frac{33}{16}$	2.09		2.42	$\frac{27}{23} \cdot \frac{33}{16}$		

- 97) Surmultiplication type -
Overdrive type
- 98) Nombre de dents -
Number of teeth
- 99) Rapport -
Ratio
- 100) Vitesses en marche AV avec surmultiplication -
Forward gears on which overdrive can be selected



Pont/moteur / Final drive

- 101) Type du pont moteur Bevel gear
Type of final drive
- 102) Type de différentiel Bevel gear
Type of differential
- 103) Nombre de dents 35 - 9
Number of teeth 31 - 6
- 104) Rapport 3.89
Ratio 5.17

Photo C

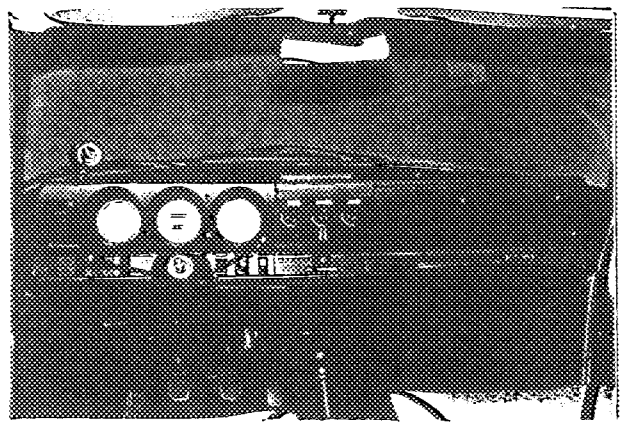

Photo D

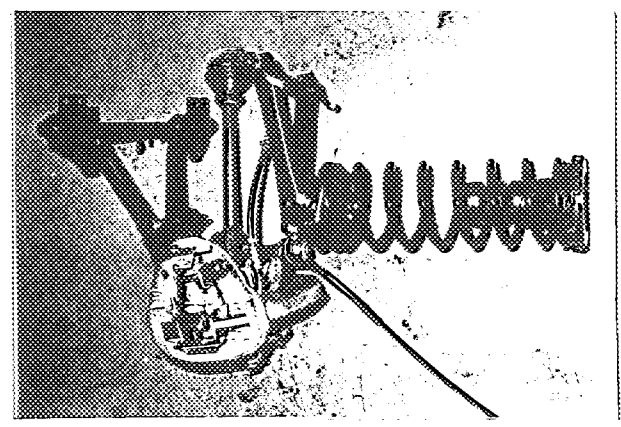

Photo E

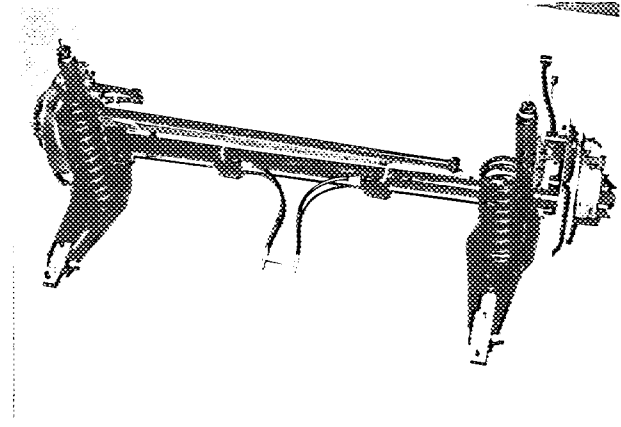

Photo F

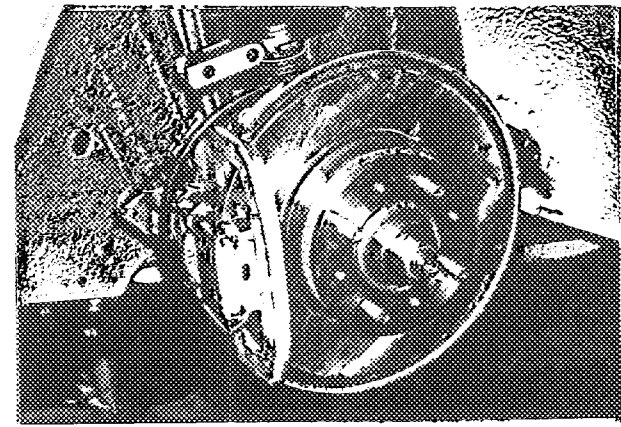

Photo G

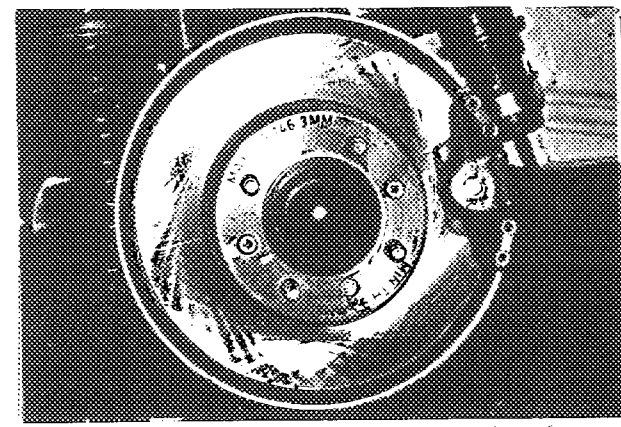

Photo H

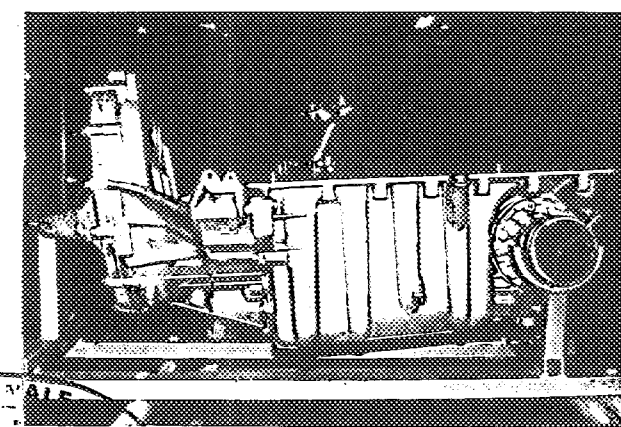

Photo I

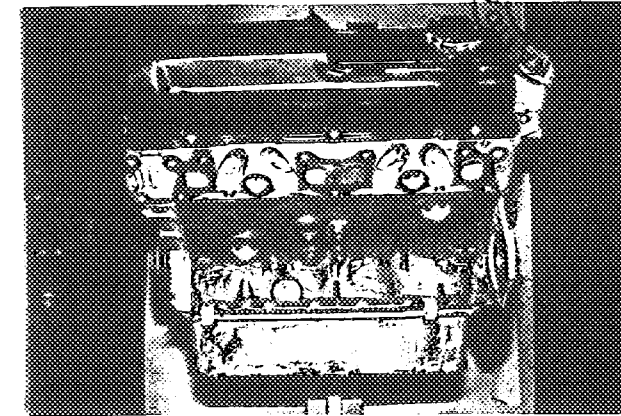
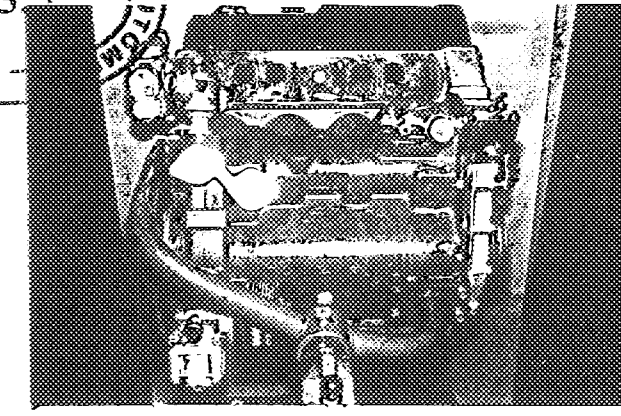
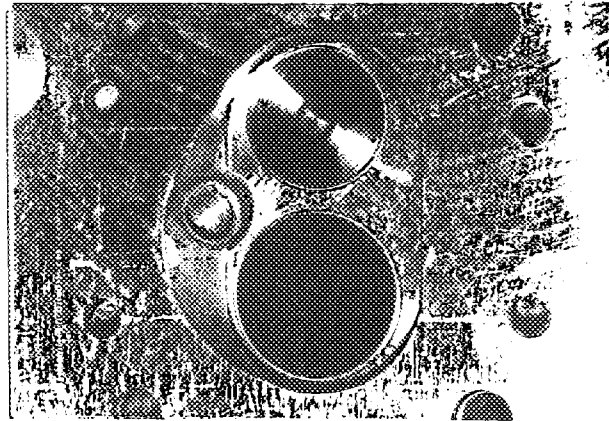

Photo J



Marque / Make SAAB Modéle / Model TURBO N° 652

Photo K



Informations supplémentaires
Additional informations.



Marque / Make SAAB Modèle / Model TURBO N° 652

COMPLÈMENT POUR LES GROUPES 1 ET 3
DU CODE SPORTIF INTERNATIONAL

ADDITIONAL DATA FOR GROUPS 1 AND 3
TO THE INTERNATIONAL SPORTING CODE

CAPACITÉS ET DIMENSIONS / CAPACITIES AND DIMENSIONS

110) Voie AV / Front track 1410 mm
111) Voie AR / Rear track 1430 mm
112) Garde au sol (pour vérification de la voie)
Ground clearance (for verification of the track) 175 mm
113) Hauteur hors-tout de la voiture / Overall height of the car 1440 mm
114) Capacité du réservoir d'essence (y compris la réserve)
Fuel tank capacity (including reserve) 58 litres
115) Nombre de places 5 116) Poids 1 155 kg
Seating capacity Weight

EQUIPEMENT ET GARNITURES / ACCESSORIES AND UPHOLSTERY

120) Chauffage intérieur : oui - non
Interior heating : yes - no
121) Climatisation (sur option) : oui - non
Air conditioning (in option) : yes - no
122) Sièges AV : type Single seats
Front seats : type
123) Sièges AR : type Seat bench
Rear seats : type

ROUES / WHEELS

124) Matériau Aluminium
Matériel
125) Poids unitaire (roue nue) 7.0 kg (tolérance $\pm 5\%$)
Unitary weight (bare wheel)
126) Diamètre de la jante 381 mm
Rim diameter
127) Largeur de la jante 139.7 mm
Rim width

SUSPENSION

130) Stabilisateur AV (si prévu) -
Front stabilizer (if fitted)
131) Stabilisateur AR (si prévu) -
Rear stabilizer (if fitted)



Marque / Make SAAB Modèle / Model TURBO N° 652

MOTEUR / ENGINE

- 135) Cylindrée par cylindre / Capacity per cylinder 496 cm³
- 136) Chemises : oui / non
Sleeves : yes / no.
- 137) Nombre d'orifices d'admission par cylindres 1
Number of inlet ports per cylinder
- 138) Nombre d'orifices d'échappement par cylindre 1
Number of exhaust ports per cylinder
- 139) Rapport volumétrique 7.2:1
Compression ratio
- 140a) Volume de la chambre de combustion (minimum) 62 cm³
Volume of the combustion chamber
- 140b) Volume de la chambre de combustion dans la culasse 48.5 ± 2 cm³
Volume of combustion chamber in head
- 141) Épaisseur du joint de culasse 1.2 ± 0.1 mm
Thickness of head gasket inter tightened
- 142) Piston, matériau Aluminium
Piston, material
- 143) Nombre de segments 3
Number of rings
- 144) Distance de la médiane de l'axe du piston au sommet du piston 40 ± 0.5 mm
Distance from gudgeon pin center line to highest point of piston crown
- 145) Capacité du réservoir - carter 4.0 litres
Capacity, lubricant
- 146) Radiateur d'huile : oui - non Yes
Oil cooler : yes - no
- 147) Capacité du circuit de refroidissement 8.0 litres
Capacity of cooling system
- 148) Ventilateur (si prévu), diamètre 282 mm Matériau Plastic
Cooling fan (if fitted), diameter Material
- 149) Nombre de pales du ventilateur 11
Number of fan blades
- 150) Paliers vilebrequin, type Shell diamètre 58 mm
Crankshaft main bearings, type diameter
- 151) Poids volant (nu) -
Weight of flywheel (clean)
- 152) Poids du volant avec couronne de démarreur 9.1 kg
Weight of flywheel with starter ring
- 153) Poids du volant avec embrayage 14.9 kg
Weight of flywheel with clutch
- 154) Poids du vilebrequin 16.0 kg
Weight of crankshaft
- 155) Poids de la bielle 0.81 kg
Weight of con-rod
- 156) Poids du piston avec axe et segments 0.7 kg
Weight of piston with rings and pin



ADMISSION / INLET

160) Matériau du collecteur d'admission Material of inlet manifold	Aluminium
161) Diamètre extérieur des soupapes Outside diameter of valves	42 ± 0.2 mm
162) Levée maximum des soupapes Maximum valve lift	9.83 mm
163) Nombre de ressorts par soupape Number of springs per valve	1
164) Type de ressort Type of spring	Coil
165) Jeu théorique pour le calage de la distribution Theoretical timing clearance	0.20 mm
166) Avance d'ouverture (avec jeu théorique) Valves open at (With tolerance for tappet clearance indicated)	40° $\begin{smallmatrix} +10 \\ -7 \end{smallmatrix}$ BTDC
167) Retard de fermeture Valves close at	68° $\begin{smallmatrix} +10 \\ -7 \end{smallmatrix}$ ABDC

ÉCHAPPEMENT / EXHAUST

170) Matériau du collecteur d'échappement Material of exhaust manifold	Cast iron
171) Diamètre extérieur des soupapes Outside diameter of valves	35.5 ± 0.2 mm
172) Levée maximum des soupapes Maximum valve lift	11.23 mm
173) Nombre de ressorts par soupape Number of springs per valve	1
174) Type de ressort Type of spring	Coil
175) Jeu théorique pour le calage de la distribution Theoretical timing clearance	0.40 mm
176) Avance d'ouverture (avec jeu théorique) Valves open at (with tolerance for tappet clearance indicated)	90° $\begin{smallmatrix} +10 \\ -7 \end{smallmatrix}$ BBDC
177) Retard de fermeture Valves close at	30° $\begin{smallmatrix} +10 \\ -7 \end{smallmatrix}$ ATDC

ALIMENTATION PAR CARBURATEURS / CARBURATION

180) Nombre de carburateurs Number of carburetors	-		
181) Type	-		
182) Marque Make	-	183) Modèle Model	-
184) Nombre de passages de gaz par carburateur Number of mixture passages per carburettor	-		



- 185) Diamètre de la tubulure de gaz à la sortie du carburateur _____
 Flange hole diameter of exit port of carburettor _____
- 186) Diamètre du diffuseur au point d'étranglement maximum _____
 Minimum diameter of venturi _____
- Injection (si prévue) (if fitted)**
- 187) Marque de la pompe _____ Bosch
 Make of pump _____
- 188) Nombre de pistons _____
 Number of plungers _____
- 189) Modèle ou type de la pompe _____ Roll cell type
 Model or type of pump _____
- 190) Nombre total d'injecteurs _____ 4
 Total number of injectors _____
- 191) Emplacement des injecteurs _____ Inlet manifold
 Location of injectors _____
- 192) Diamètre de la pipe d'admission au point de passage le plus étroit _____ 55 mm
 Minimum diameter of inlet pipe _____

ÉQUIPEMENT DU MOTEUR / ENGINE ACCESSORIES

- 195) Pompe à essence - mécanique et/ou électrique _____ Electrical
 Fuel pump - mechanical and/or electrical _____
- 196) Nombre _____ 1
 Number _____
- 197) Type du système d'allumage _____ Distributor and coil
 Type of ignition system _____
- 198) Nombre de bobines _____ 1
 Number of ignition coils _____
- 199) Génératrice : type Alternator Nombre 1
 Generator : type _____ Number _____
- 200) Système d'entraînement _____ Belt
 Method of drive _____
- 201) Batterie / Battery
- a) Tension _____ 12 (14)
 Voltage _____
- b) Emplacement _____ Engine compartment
 Location _____
- 205) Arbres à cames / Camshaft

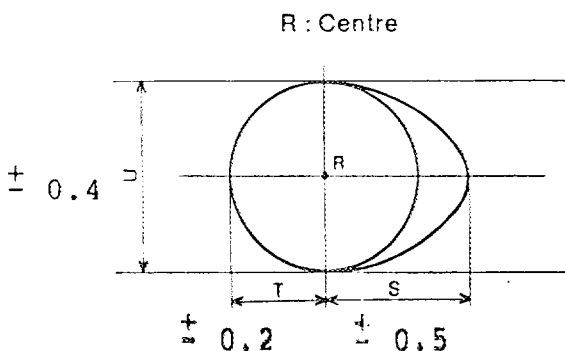

Came admission / Inlet cam * Came échappement / Exhaust cam

S = 28.63 mm _____ inches S = 29.83 mm _____ inches
 T = 19.50 mm _____ inches T = 19.30 mm _____ inches
 U = 39.06 mm _____ inches U = 39.10 mm _____ inches

TRANSMISSION AUX ROUES / WHEEL DRIVE

Embrayage / clutch

- 210) Type Diaphragm spring
- 211) Diamètre / Diameter 219 mm
- 212) Diamètre des garnitures : intérieur 146 mm extérieur 217 mm
Diameter of linings : interior outside
- 213) Nombre de disques 1
Number of discs

Boîte de vitesses / Gear-box

- 215) Nombre de rapports AV synchronisés 4
Number of forward synchronised ratios
- 216) Emplacement de la commande Floor
Location of the gear lever
- 217) Boîte automatique - emplacement de la commande Floor
Automatic gear-box - location of gear lever
- 218) Surmultiplication - type -
Overdrive type
- 219) Rapport de surmultiplication -
Overdrive ratio

Pont moteur - Final drive

- 220) Type du pont autobloquant (si prévu) -
Type of limited slip differential (if provided)
- 221) Nombre de dents du couple conique 35 - 9 ou 31 - 6
Number of teeth of final drive or
- 222) Rapport au couple conique 3.89 ou 5.17
Final drive ratio or



Photo K

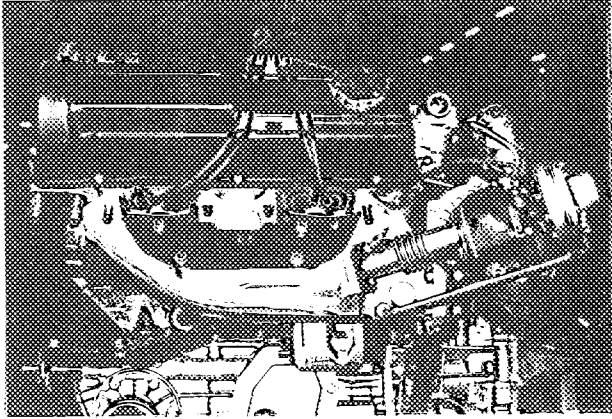

Photo L

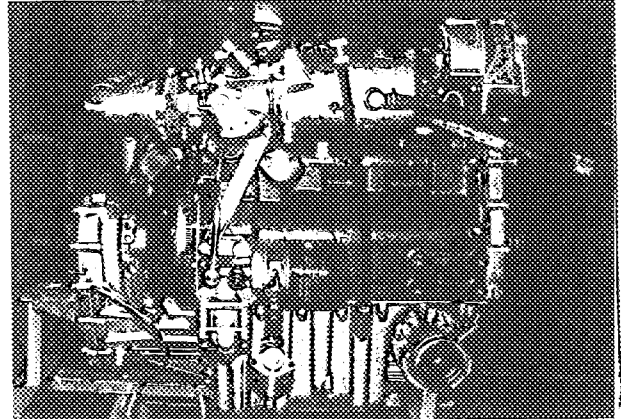

Photo M

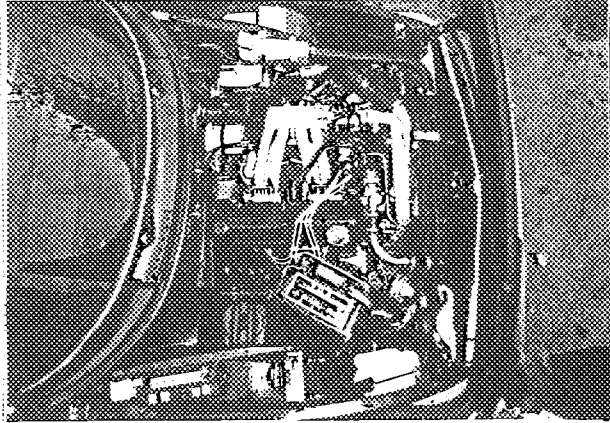

Photo N

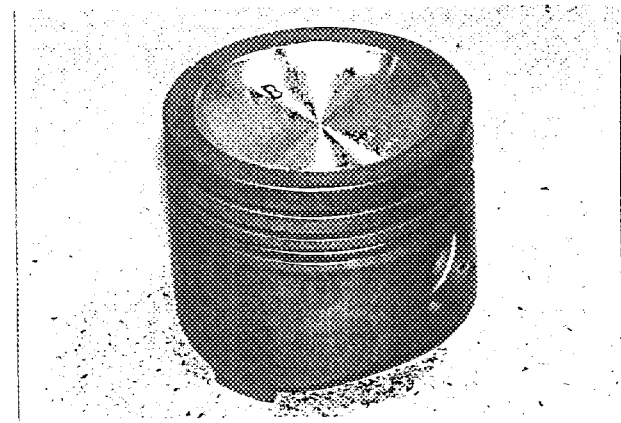

Photo P

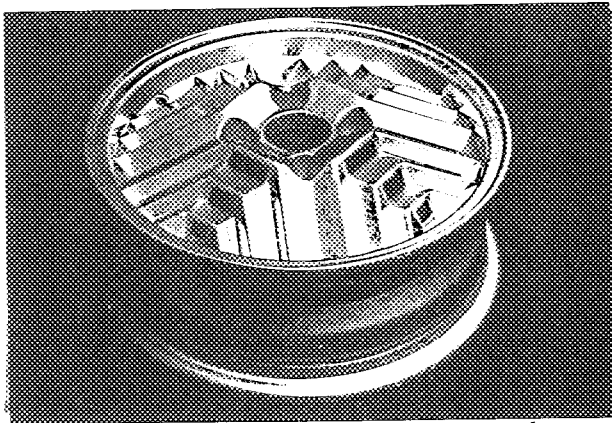

Photo Q

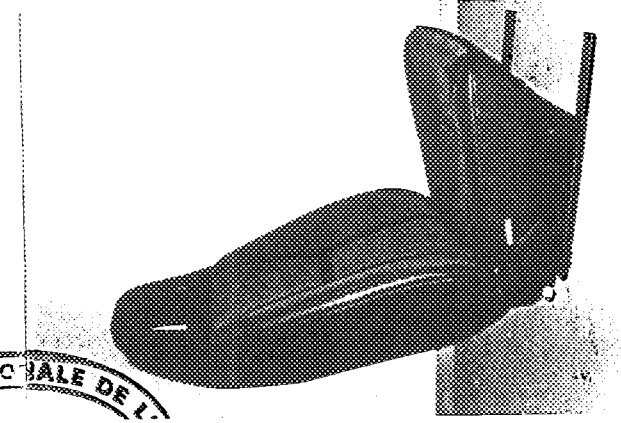

Photo R

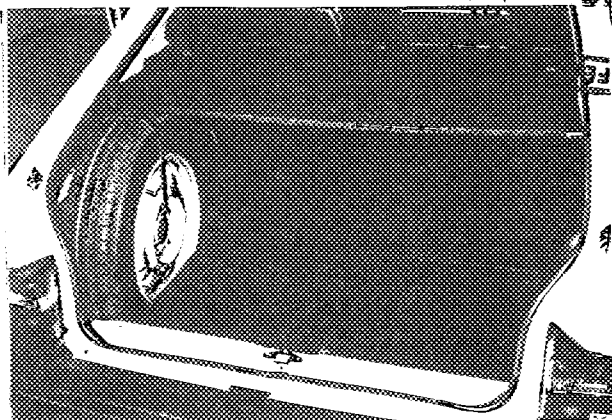
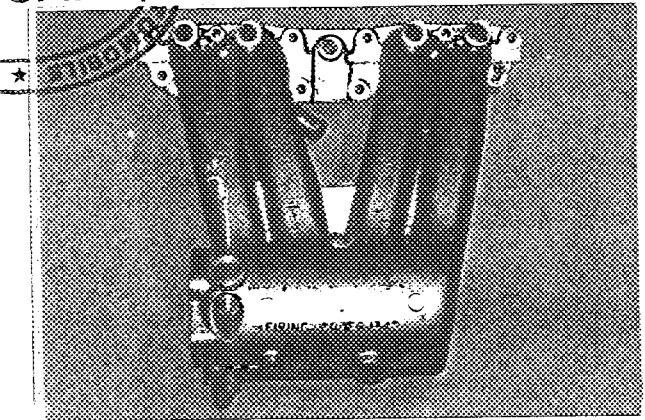

Photo S



CHALE DE L'...
C. S. I.
STROU...

Dessin orifices collecteur admission, face côté culasse.

Drawing inlet manifold ports, side of cylinderhead.

avec dimensions
with

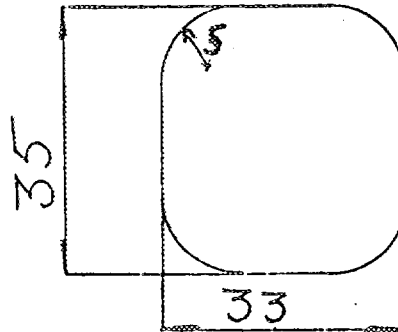

Dessin orifices admission culasse face collecteur.

Drawing of entrance to inlet port of cylinderhead.

avec dimensions
with

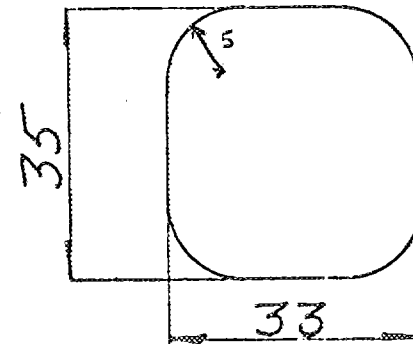

Tolerances as for unfinished castings.
(Ports chamfered 1 mm 30°)

Dessin orifices collecteur échappement face côté culasse.

Drawing of exhaust manifold ports, side of cylinderhead.

avec dimensions
with

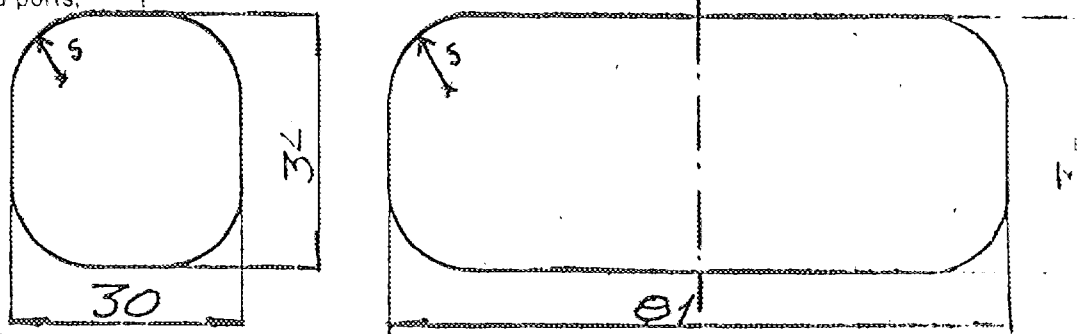

Dessin orifices échappement culasse face collecteur.

Drawing of exit to exhaust port cylinderhead.

avec dimensions
with

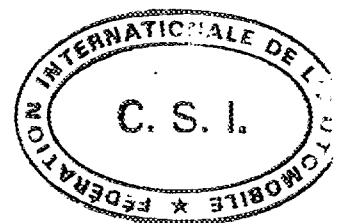
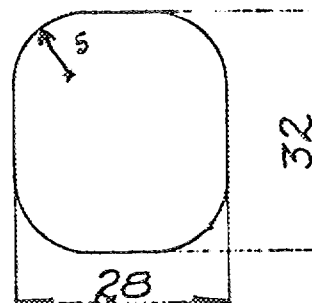

Photo T

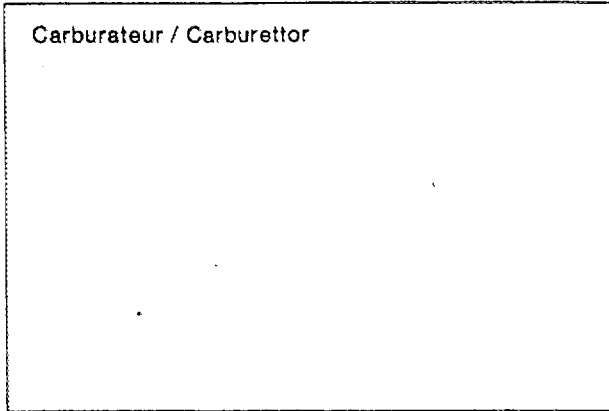

Photo U

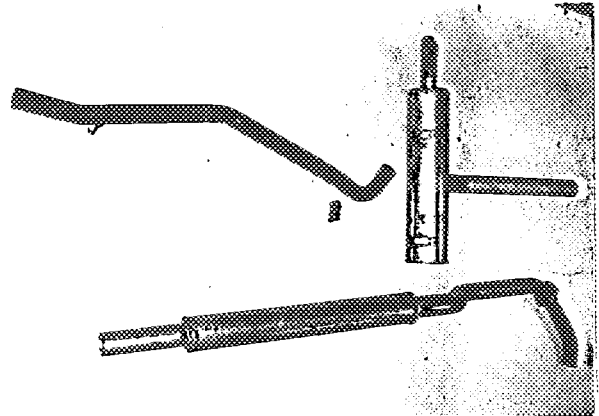
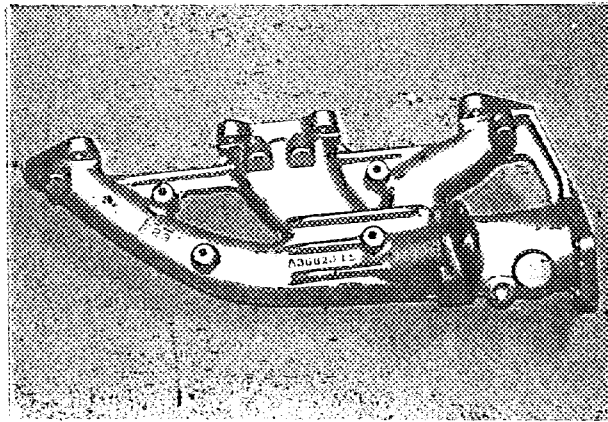

Photo V



Informations supplémentaires

Additional informations

Inlet and exhaust manifolds, ports and ducts machined in series production.

Exit port of exhaust manifold: 45 x 57 mm (radius of corners 10 mm)

Photo W

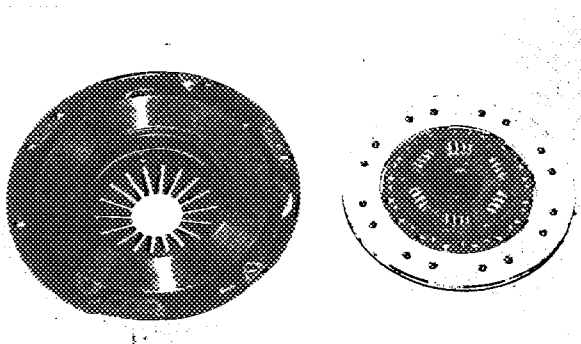

Grille de vitesses
Gear change gate

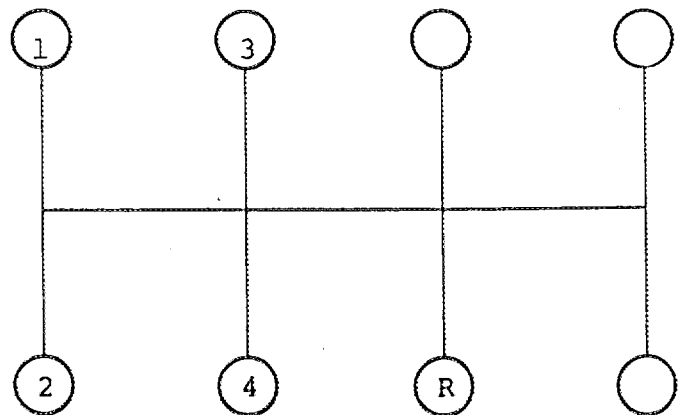

Additional form for turbo-compressor.

TURBO-COMPRESSOR SPECIFICATIONS

Make: Airesearch Model: TCO 30

1. Exhaust component:

- . gas entry diameter: 57.2 x 44.7 mm^{x)}
- . gas exit diameter: 47.2 mm^{x)}
- . blade width: 26.6 ± 0.5 mm

2. Intake component:

- . air entry diameter: 53 mm^{x)}
- . air exit diameter: 35.6 mm^{x)}
- . blade width: 19.8/14.2 ± 0.5 mm

3. Relief valve:

- . spring characteristic: 23.4 ± 1.5 N/mm
- . length of spring unmounted: 22 ± 0.5 mm
- . length of spring mounted: 19.9 ± 1.1 mm
- . diameter of spring thread: 3 mm
- . diameter of spring: 28 mm
- . force exerted by mounted spring: 49 ± 13 N

4. Exhaust diameter at the exit into the atmosphere: 51 mm

^{x)} Tolerances as for unfinished castings.

1.

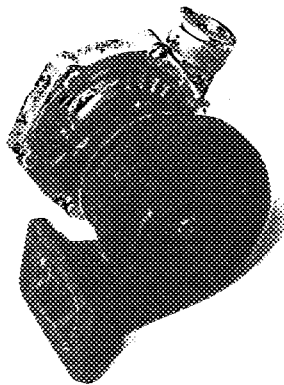

2.

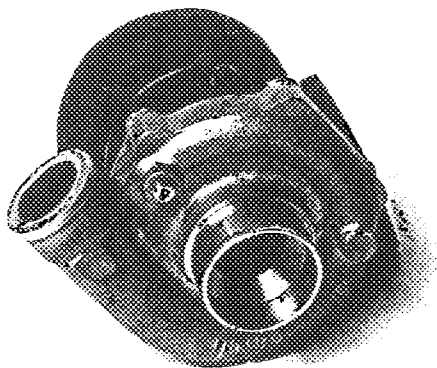

3.

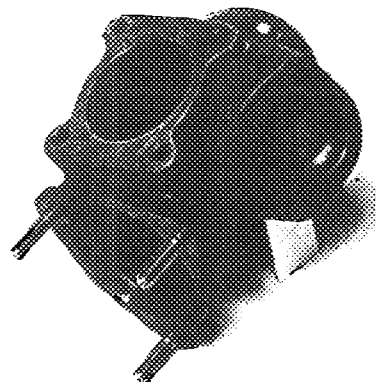

Make SAAB Model TURBO No

1.

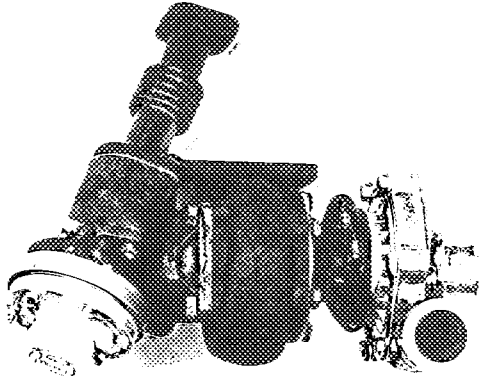

2.

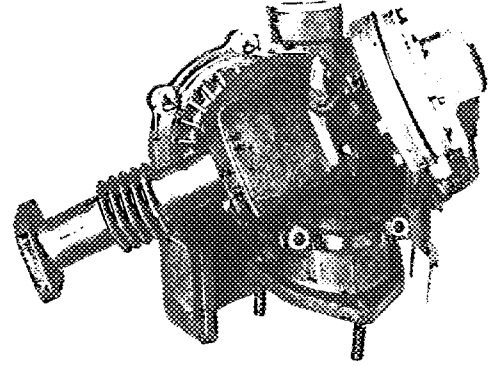

3.

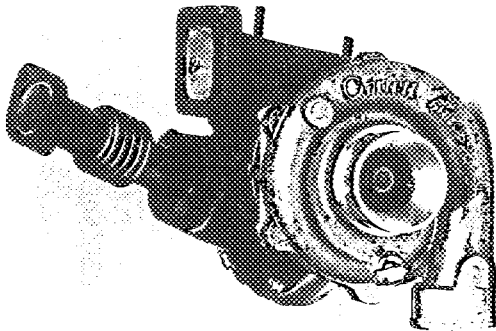

4.

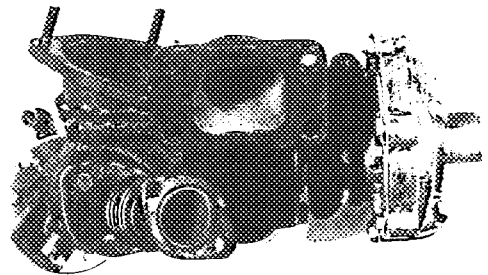

5.

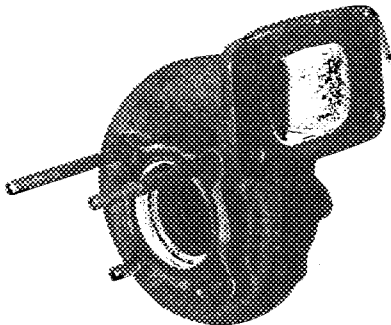

6.

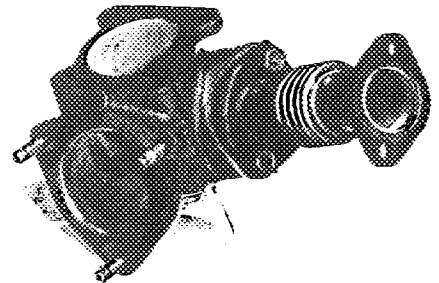

7.

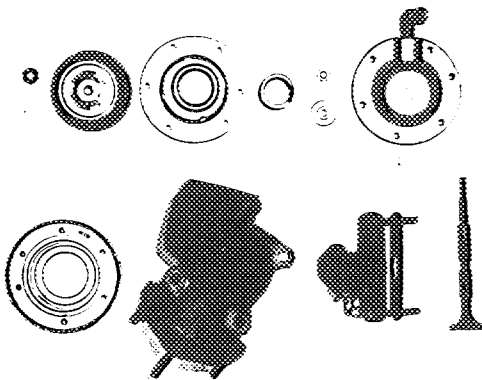

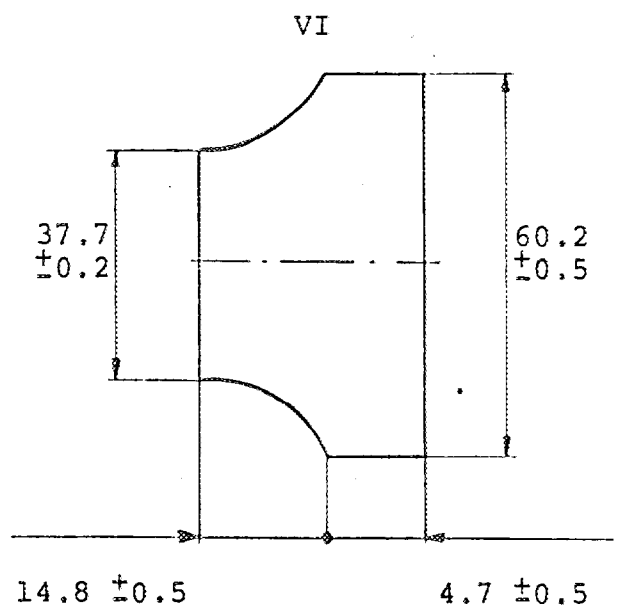
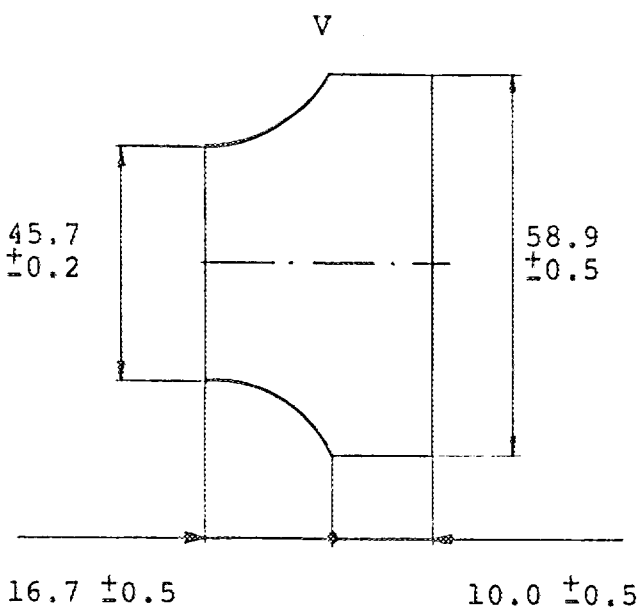
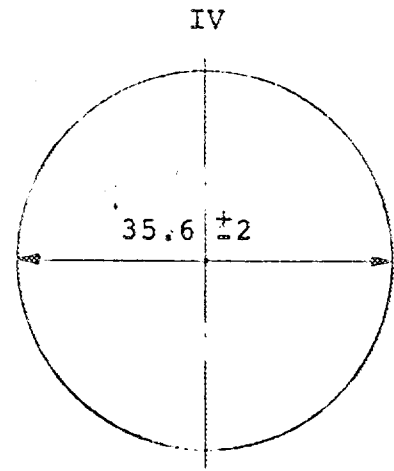
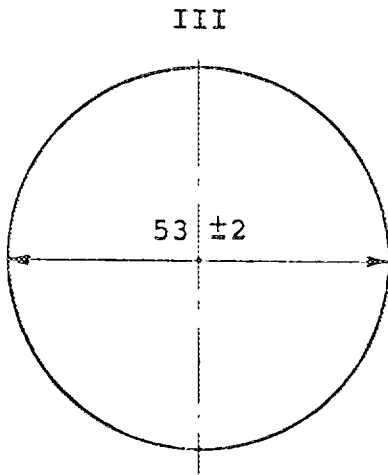
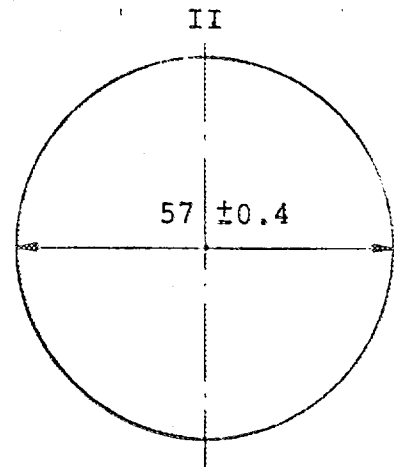
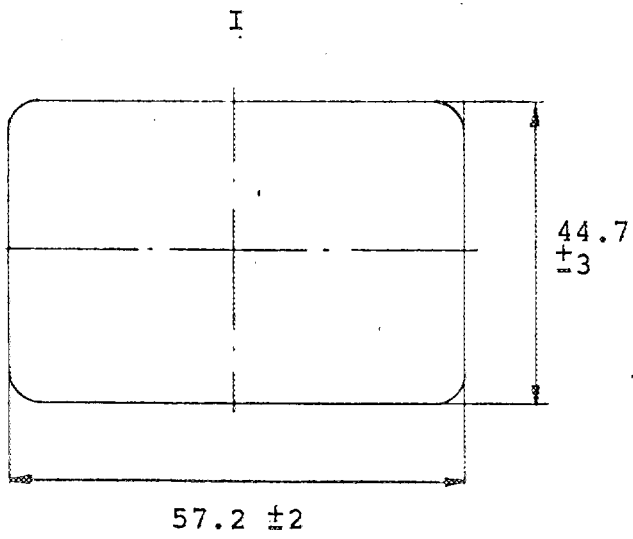

FEDERATION INTERNATIONALE DE L'AUTOMOBILE

Form of recognition (extension) in accordance with Appendix J to the International Sporting Code.

Manufacturer SAAB-SCANIA AB

Model SAAB 99 TURBO

Serial No. inaugurating this extension

Chassis

Manufacturing date of the first vehicle constructed with the modifications

Engine

Commercial denomination of modified model

This extension of recognition is considered:

variation - ~~normal~~
development of original
vehicle type

Recognition is valid from -1 JAN 1978

List

Description of modifications:

Strengthened upper wishbone

No 15230 and No 15248

Strengthened lower wishbone

No 15255 and No 15263

Strengthened rear axle

No 18002 (photo exchanged)

Roll bar attachment

(see photo)

41. Power steering

No 860930 (2)

80. Dry sump lubrication kit

No 18010 (see photo)

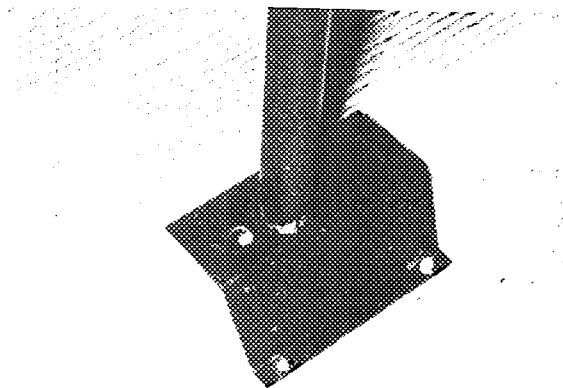
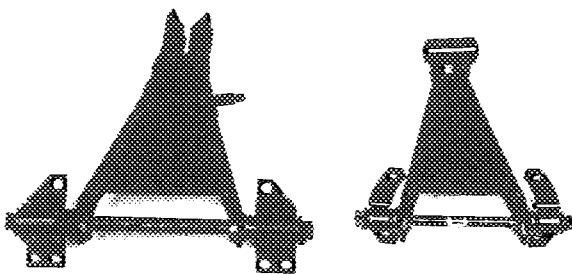

"valable en Groupe 4 uniquement"

"valid for Group 4 only"

Signature and stamp of the National Sporting Authority:

Signature and stamp of the F.I.A.:

SVENSKA BILSPORTFÖRBUNDET
THE SWEDISH AUTOMOBILE SPORT FEDERATION



FEDERATION INTERNATIONALE DE L'AUTOMOBILE

Form of recognition (extension) in accordance with
Appendix J to the International Sporting Code.

Manufacturer	SAAB-SCANIA AB	Model	SAAB 99 TURBO
Serial No. inaugurating this extension		Chassis	
Manufacturing date of the first vehicle constructed with the modifications		Engine	
Commercial denomination of modified model			
This extension of recognition is considered:		variation - normal	
		development of original	
		vehicle type	
Recognition is valid from	-1 JAN 1978	List	

Description of modifications:

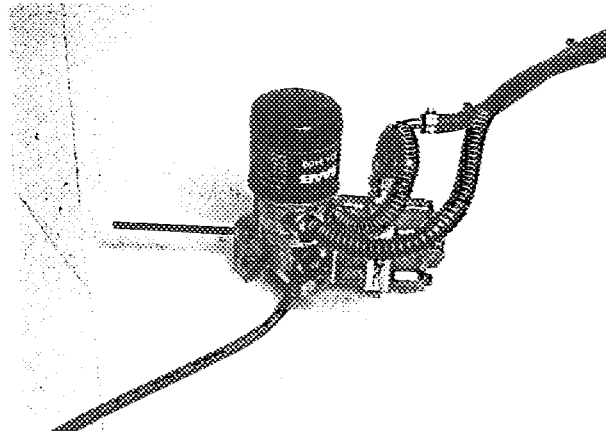

FEDERATION INTERNATIONALE DE L'AUTOMOBILE

Form of recognition (extension) in accordance with Appendix J to the International Sporting Code.

Manufacturer SAAB-SCANIA AB
 Serial No. inaugurating this extension
 Manufacturing date of the first vehicle constructed with the modifications
 Commercial denomination of modified model

Model SAAB 99 TURBO
 Chassis
 Engine

SAAB 99 TURBO

This extension of recognition is considered:

~~variation -~~
~~development of original~~
~~vehicle type~~
 List **valable en Groupe 4 uniquement**
"valid for Group 4 only"

Recognition is valid from -1.JAN.1978

Description of modifications:

	Front	Rear
Brakes Teves type	2 L4 34	LC ₁ 33W
93. Number of cylinders per wheel	4	2
94. Bore of wheel cylinders	34 mm	33 mm
100. Outside diameter (ventilated disc)	270 mm	-
101. Thickness of disc	22 mm	-
102. Length of brake linings	77 mm	56 mm
103. Width of brake linings	43 mm	38 mm
104. Number of pads per shoe	2	2
105. Total area per brake	59800 mm ²	54700 mm ²

Pressure limiting valve Teves type BR 18

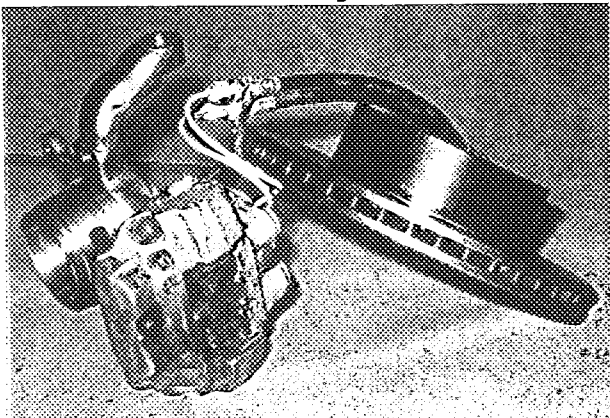

Signature and stamp of the National Sporting Authority:

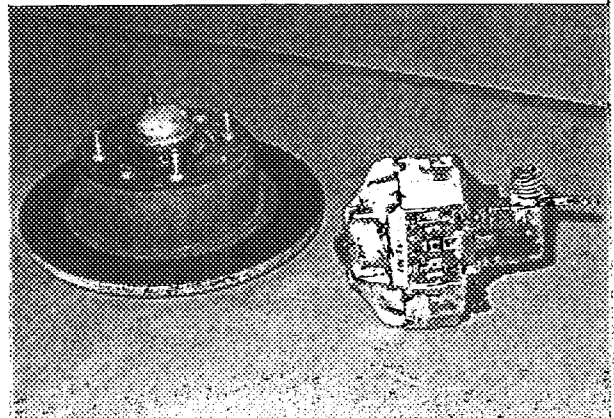

Signature and stamp of the F.I.A.:

SVENSKA BILSPORTFORBUNDET
 THE SWEDISH AUTOMOBILE SPORT FEDERATION

[Handwritten signature]

[Handwritten signature]

