

FÉDÉRATION INTERNATIONALE DE L'AUTOMOBILE

FICHE D'HOMOLOGATION CONFORME A L'ANNEXE J DU CODE SPORTIF INTERNATIONAL
POUR LES VOITURES DES GROUPES 1 A 5

BOOK OF RECOGNITION IN ACCORDANCE WITH APPENDIX J TO THE INTERNATIONAL
SPORTING CODE FOR CARS OF GROUPS 1 TO 5

Constructeur/Manufacturer SAAB-SCANIA AB Modèle / Model SAAB 900 TURBO
Cylindrée / Cylinder capacity 1985 (2780)
Constructeur du châssis / Chassis Manufacturer SAAB-SCANIA AB
Constructeur du moteur / Engine Manufacturer SAAB-SCANIA AB
Homologation valable à partir du / Recognition valid as from -1.OCT.1977

Modèle homologué en groupe 1.
Model recognized in group

Numéro d'homologation 7504578
Recognition number

Photo A : voiture vue de 3/4 AV
Photo A : 3/4 view of car from front

Photo B : voiture vue de 3/4 AR
Photo B : 3/4 view of car from rear

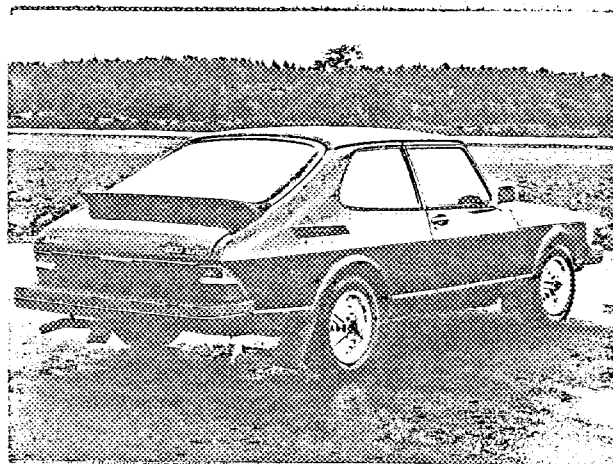
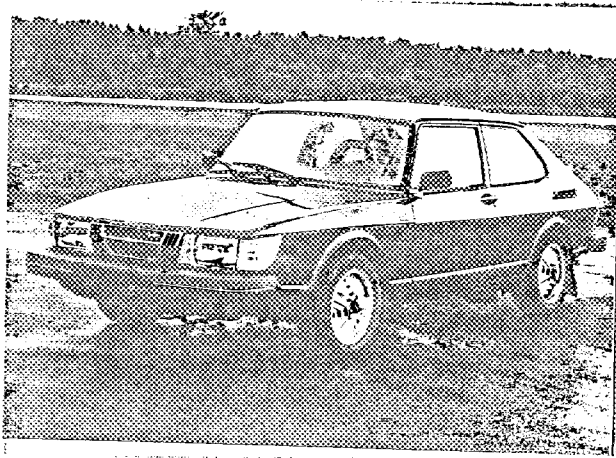

CARACTÉRISTIQUES GÉNÉRALES / GENERAL CHARACTERISTICS :

- 1) Mode de construction : construction séparée / monocoque.
Type of car construction : separate / unitary construction.
- 2) Matériau du châssis Steel Matériau de la carrosserie Steel/aluminium
Material of chassis Material of coachwork
- 3) Empattement droit 2525 mm Gauche 2525 mm
Wheelbase right Left
- 4) Largeur de la carrosserie mesurée aux axes AV 1650 mm
Width of bodywork measured at front axle
- 5) Largeur de la carrosserie mesurée aux axes AR 1690 mm
Width of bodywork measured at rear axle
- 6) Longueur hors-tout avec pare-chocs 4739 mm Sans pare-chocs 4500 mm
Overall length with bumpers Without bumpers
- 7) Type de suspension : AV Independent AR Rigid axle with trailing arms
Type of suspension : Front Rear

(Photo D)

(Photo E)

Signature et cachet de
l'autorité sportive nationale,

Signature et cachet
de la F.I.A.,

SVENSKA BILSPORTFÖRBUNDET
THE SWEDISH AUTOMOBILE-SPORT FEDERATION



MOTEUR :

- 8) Cycle 4-stroke
- 9) Nombre et disposition des cylindres 4 in line
Number and disposition of cylinders
- 10) Système de refroidissement Water cooling
Cooling system
- 11) Emplacement et position du moteur Front, in line
Location and position of engine
- 12) Matériau du bloc moteur Cast iron
Material of engine block
- 13) Roues motrices : AV - AR Front
Drive wheels : Front - Rear
- 14) Emplacement de la boîte de vitesses Below the engine in a compact unit
Location of gear-box

CARROSSERIE ET ÉQUIPEMENT INTÉRIEUR / COACHWORK AND INTERIOR

- 20) Nombre de portes 2 doors (1 rear gate)
Number of doors
- 21) Matériau des portes : AV Steel sheet AR
Material of doors : Front Steel sheet Rear
- 22) Matériau du capot moteur Steel sheet
Material of bonnet
- 23) Matériau du capot coffre Steel sheet
Material of boot lid
- 24) Matériau de la lunette AR Safety glass
Material of rear window
- 25) Matériau du pare-brise Laminated glass
Material of windscreen
- 26) Matériau des glaces des portières AV Safety glass
Material of front door windows
- 27) Matériau des glaces des portières AR -
Material of rear door windows
- 28) Système d'ouverture des vitres portières AV Wheel and lever
Sliding system of door windows Front machanism AR -
mechanical Rear
- 29) Matériau des glaces de custode Safety glass
Material of rear quarter lights
- 30) Poids siège (s) AV (enlevés de la voiture avec dossiers, glissières et supports) 15.5 kg
Weight of front seat(s) (complete with supports and rails, out of the car)
- 31) Matériau du pare-choc AV Aluminium, plastic, rubber Poids 10.0 kg
Front bumper material Weight
- 32) Matériau du pare-choc AR Aluminium, plastic, rubber Poids 9.0 kg
Rear bumper material Weight
- 33) Ventilation : oui non / yes no



Marque / Make SAAB Modèle / Model 900 TURBO N° 1053

5764 U

DIRECTION / STEERING

40) Type Rack and pinion
 41) Servo-assistance Yes

SUSPENSION

45) Suspension AV (photo D) Type de ressort Coil spring
 Front suspension (photo D) Type of spring
 46) Nombre d'amortisseurs 2
 Number of shock absorbers
 47) Suspension AR (Photo E) Type de ressort Coil spring
 Rear suspension (Photo E) Type of spring
 48) Nombre d'amortisseurs 2
 Number of shock absorbers
 49) Système de fixation des roues Bolt and nut
 Method of fixation of wheels

FREINS - BRAKES

50) Système Hydraulic
 Method of operation
 51) Servo frein (si prévu) Type : Vacuum
 Servo assistance (if fitted) Type :
 52) Nombre de maîtres-cylindres 1 tandem type
 Number of master-cylinders

	AVANT / FRONT	ARRIERE / REAR
53) Nombre de cylindres par roue Number of cylinders per wheel	1	2
54) Alésage Bore	54 mm	30 mm
Freins à tambour / Drum brakes		
55) Diamètre intérieur Inside diameter		
56) Nombre de mâchoires par frein Number of shoes per brake		
57) Surface de freinage par frein Total area per brake		
Freins à disques / Disc brakes		
58) Largeur des sabots Width of brake linings	52 mm	38 mm
59) Nombre de sabots par frein Number of pads per brake	2	2
60) Surface de freinage par frein Total area per brake	70 450 mm ²	54 750 mm ²



MOTEUR / ENGINE

- 65) Alésage 90 mm
Bore
- 67) Course 78 mm
Stroke
- 68) Cylindrée totale 1985 (2780) 69) Cylindrée maximum autorisée 2012-(2816)
Total cylinder-capacity Maximum cylinder-capacity allowed
- 70) Culasse : matériau Aluminium 71) Nombre 1
Head : material Number
- 72) Type de vilebrequin Integral Coulé / estampé Stamped
Type of crankshaft ~~Moulié / stamped~~
- 73) Nombre de paliers de vilebrequin 5
Number of crankshaft main bearings
- 74) Diamètre maximal des manetons de vilebrequin 52 mm
Maximum diameter of the big end journal
- 75) Tête de bielle : type Shell diamètre 52 mm
Connecting rod big end type
- 76) Matériau des chapeaux des paliers de vilebrequin Cast iron
Material of bearing cap
- 77) Matériau du volant moteur Steel
Material of flywheel
- 78) Matériau du vilebrequin Steel
Crankshaft material
- 79) Matériau de la bielle Steel
Connecting rod material
- 80) Système de graissage : carter sec • carter humide Oil in sump
Lubrication system : dry-sump • oil in sump
- 81) Nombre de pompes à huile 1
Number of oil pumps

Moteur 4 temps / 4 stroke engines

- 82) Nombre d'arbres à cames 1 Emplacement Overhead
Number of camshafts Location
- 83) Système de commande Chain
Type of camshaft drive
- 84) Système de commande des soupapes Cam to tappet
Type of valve operation
- 85) Nombre de soupapes d'admission par cylindre 1
Number of inlet valves per cylinder
- 86) Nombre de soupapes d'échappement par cylindre 1
Number of exhaust valves per cylinder
- 87) Nombre de distributeurs 1
Number of distributors
- 88) Nombre de bougies par cylindre 1
Number of spark plug per cylinder



Marque / Make SAAB Modèle / Model 900 TURBO N° 15

5764 U

TRANSMISSION AUX ROUES / DRIVE TRAIN

Embrayage / Clutch

90) Nombre de disques / Number of plates 1

91) Système de commande / Method of operating clutch Hydraulic

Boîte de vitesses / Gear-box

92) Contrôle manuel, marque / Manual type, make SAAB-SCANIA

93) Nombre de rapports AV / Number of gear-box ratios forward 4

94) Boîte automatique, marque / Automatic, make _____

95) Nombre de rapports AV / Number of gear-ratios forward _____

96	Manuelle / Manual		Automatique		Supp. manuel / Automatique			
	Rapport Ratio	N. dents Nr teeth	Rapport Ratio	N. dents Nr teeth	Rapport Ratio	N. dents Nr teeth	Rapport Ratio	N. dents Nr teeth
1	3.44	$\frac{33}{18} \cdot \frac{30}{16}$						
2	2.07	$\frac{33}{18} \cdot \frac{26}{23}$						
3	1.39	$\frac{33}{18} \cdot \frac{22}{29}$						
4	1.00							
5								
6								
M. AR / Rev.	3.78	$\frac{33}{18} \cdot \frac{33}{16}$						

97) Surmultiplication type / Overdrive type _____

98) Nombre de dents / Number of teeth _____ 99) Rapport Ratio _____

100) Vitesses en marche AV avec surmultiplication / Forward gears on which overdrive can be selected _____



Pont/moteur / Final drive

101) Type du pont moteur / Type of final drive Bevel gear 102) Type de différentiel / Type of differential Bevel gear

35 - 9

3.89

103) Nombre de dents / Number of teeth 31 - 6 104) Rapport Ratio 5.17

34 - 7

4.86

Photo C

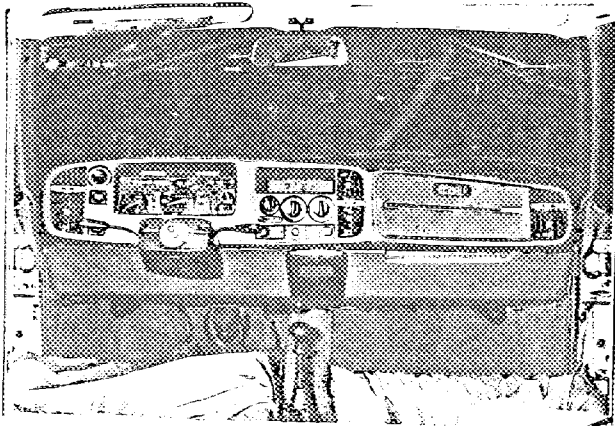

Photo D

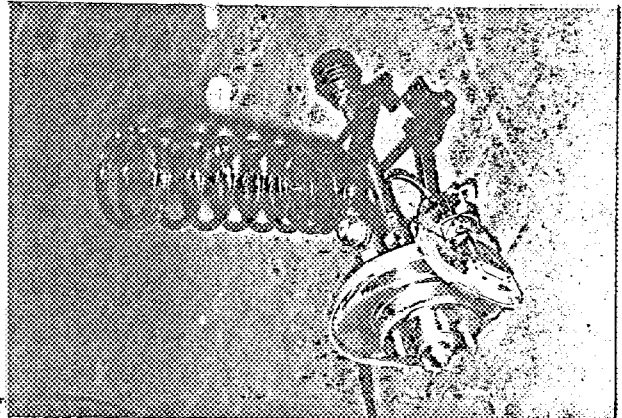

Photo E

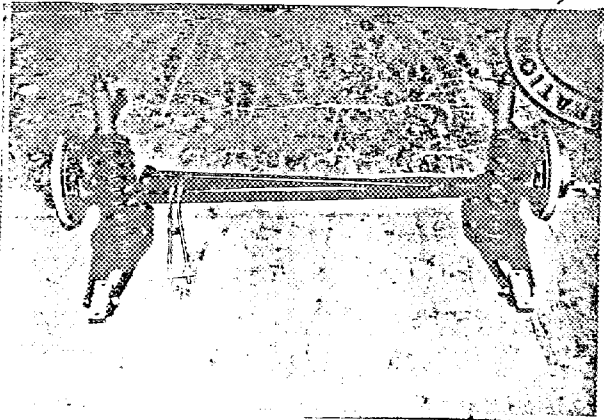

Photo F

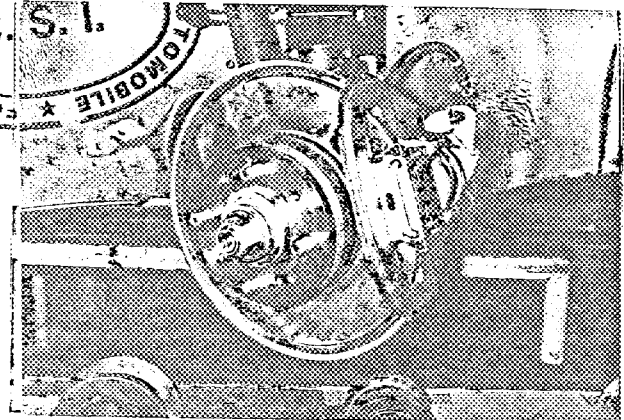

Photo G

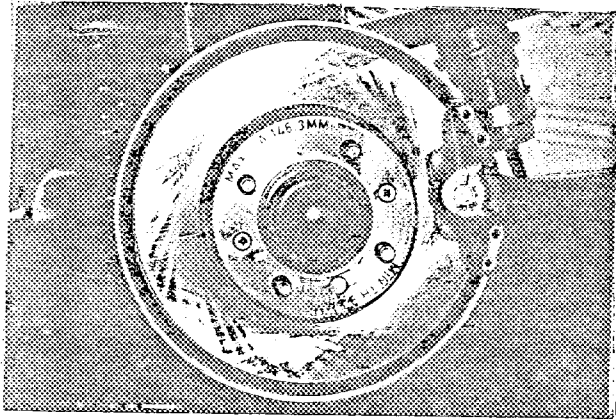

Photo H

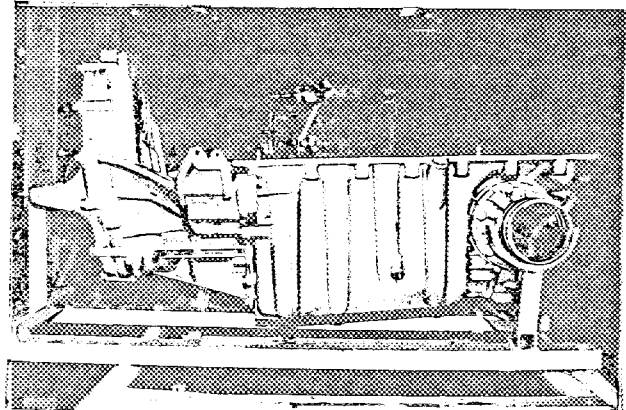

Photo I

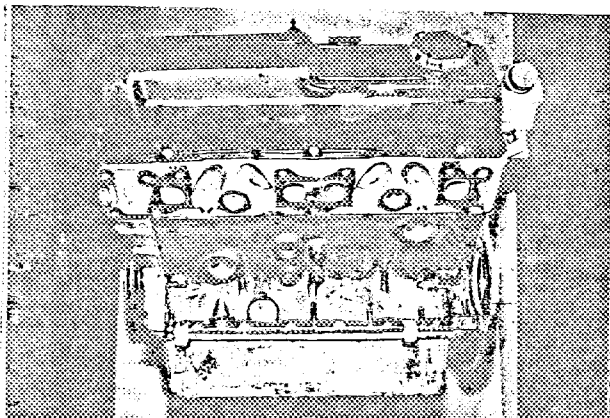

Photo J

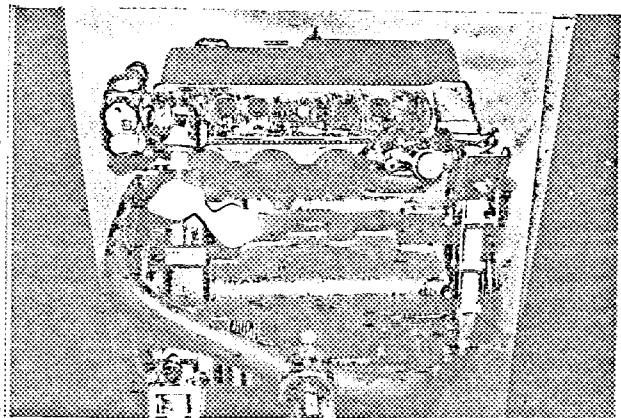
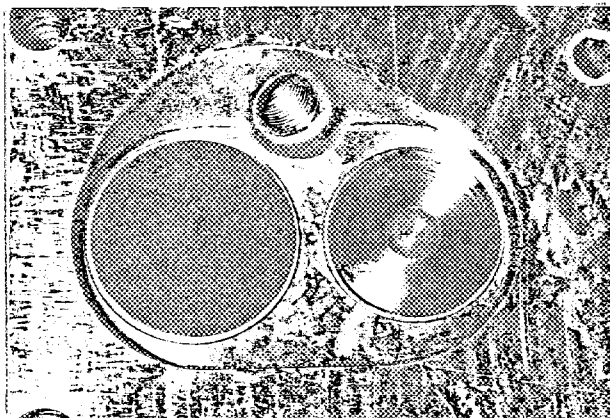

Photo K



Informations supplémentaires
Additional informations.

- 3) a. Overhang front 1050 mm
- b. Overhang rear 1164 mm

BRAKES

- 61) Thickness of discs front 12.8 ± 0.2 mm
- rear 10.5 ± 0.2 mm

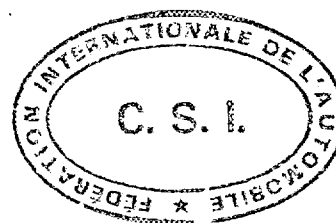

Marque / Make SAAB Modèle / Model 900 TURBO N° 5764

5764

COMPLÉMENT POUR LES GROUPES 1 ET 3
DU CODE SPORTIF INTERNATIONAL

ADDITIONAL DATA FOR GROUPS 1 AND 3
TO THE INTERNATIONAL SPORTING CODE

CAPACITÉS ET DIMENSIONS / CAPACITIES AND DIMENSIONS

- 110) Voie AV / Front track 1430 mm
111) Voie AR / Rear track 1440 mm
112) Garde au sol (pour vérification de la voie)
Ground clearance (for verification of the track) 150 mm
113) Hauteur hors-tout de la voiture / Overall height of the car 1420 mm
114) Capacité du réservoir d'essence (y compris la réserve)
Fuel tank capacity (including reserve) 55 litres
115) Nombre de places 5 116) Poids 1130 kg
Seating capacity Weight

EQUIPEMENT ET GARNITURES / ACCESSORIES AND UPHOLSTERY

- 120) Chauffage intérieur : oui - non
Interior heating : yes - ~~no~~
121) Climatisation (sur option) : oui - non
Air conditioning (in option) : yes - ~~no~~
122) Sièges AV : type Single seats
Front seats : type
123) Sièges AR : type Seat bench
Rear seats : type

ROUES / WHEELS

- 124) Matériau Aluminium
Matériel
125) Poids unitaire (roue nue) 7.0 kg (tolérance $\pm 5\%$)
Unitary weight (bare wheel)
126) Diamètre de la jante 381 mm
Rim diameter
127) Largeur de la jante 139.7 mm
Rim width

SUSPENSION

- 130) Stabilisateur AV (si prévu)
Front stabilizer (if fitted)
131) Stabilisateur AR (si prévu)
Rear stabilizer (if fitted)

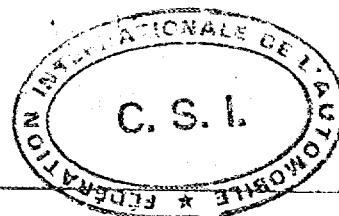

Marque / Make SAAB Modèle / Model 900 TURBO N° 1074

5764 U

MOTEUR / ENGINE

- 135) Cylindrée par cylindre / Capacity per cylinder 496 cm³
- 136) Chemises : oui / non
Sleeves ~~yes~~ / no. no
- 137) Nombre d'orifices d'admission par cylindres
Number of inlet ports per cylinder 1
- 138) Nombre d'orifices d'échappement par cylindre
Number of exhaust ports per cylinder 1
- 139) Rapport volumétrique
Compression ratio 7.2:1
- 140a) Volume de la chambre de combustion (minimum)
Volume of the combustion chamber 75 cm³
- 140b) Volume de la chambre de combustion dans la culasse
Volume of combustion chamber in head 48.5 ± 2 cm³
- 141) Épaisseur du joint de culasse
Thickness of head gasket inter tightened 1.2 ± 0.1 mm
- 142) Piston, matériau
Piston, material Aluminium
- 143) Nombre de segments
Number of rings 3
- 144) Distance de la médiane de l'axe du piston au sommet du piston
Distance from gudgeon pin center line to highest point of piston crown 40 ± 0.5 mm
- 145) Capacité du réservoir - carter
Capacity, lubricant 4.0 litres
- 146) Radiateur d'huile : oui - non
Oil cooler : yes - ~~no~~
- 147) Capacité du circuit de refroidissement
Capacity of cooling system 10 litres
- 148) Ventilateur (si prévu), diamètre
Cooling fan (if fitted), diameter 279.5 mm Matériau Plastic
Material
- 149) Nombre de pales du ventilateur
Number of fan blades 5
- 150) Paliers vilebrequin, type
Crankshaft main bearings, type Shell diamètre 58 mm
diameter
- 151) Poids volant (nu)
Weight of flywheel (clean) -
- 152) Poids du volant avec couronne de démarreur
Weight of flywheel with starter ring 9.1 kg
- 153) Poids du volant avec embrayage
Weight of flywheel with clutch 14.9 kg
- 154) Poids du vilebrequin
Weight of crankshaft 16.0 kg
- 155) Poids de la bielle
Weight of con-rod 0.81 kg
- 156) Poids du piston avec axe et segments
Weight of piston with rings and pin 0.690 kg

ADMISSION / INLET

160) Matériau du collecteur d'admission Material of inlet manifold	<u>Aluminium</u>
161) Diamètre extérieur des soupapes Outside diameter of valves	<u>42 ± 0.2 mm</u>
162) Levée maximum des soupapes Maximum valve lift	<u>9.83 mm</u>
163) Nombre de ressorts par soupape Number of springs per valve	<u>1</u>
164) Type de ressort Type of spring	<u>Coil</u>
165) Jeu théorique pour le calage de la distribution Theoretical timing clearance	<u>0.20 mm</u>
166) Avance d'ouverture (avec jeu théorique) Valves open at (With tolerance for tappet clearance indicated)	<u>40° $\begin{smallmatrix} +10 \\ -7 \end{smallmatrix}$ BTDC</u>
167) Retard de fermeture Valves close at	<u>68° $\begin{smallmatrix} +10 \\ -7 \end{smallmatrix}$ ABDC</u>

ÉCHAPPEMENT / EXHAUST

170) Matériau du collecteur d'échappement Material of exhaust manifold	<u>Cast iron</u>
171) Diamètre extérieur des soupapes Outside diameter of valves	<u>34.5 ± 0.2 mm</u>
172) Levée maximum des soupapes Maximum valve lift	<u>11.23 mm</u>
173) Nombre de ressorts par soupape Number of springs per valve	<u>1</u>
174) Type de ressort Type of spring	<u>Coil</u>
175) Jeu théorique pour le calage de la distribution Theoretical timing clearance	<u>0.40 mm</u>
176) Avance d'ouverture (avec jeu théorique) Valves open at (with tolerance for tappet clearance indicated)	<u>90° $\begin{smallmatrix} +10 \\ -7 \end{smallmatrix}$ BBDC</u>
177) Retard de fermeture Valves close at	<u>30° $\begin{smallmatrix} +10 \\ -7 \end{smallmatrix}$ ATDC</u>

ALIMENTATION PAR CARBURATEURS / CARBURATION

180) Nombre de carburateurs Number of carburetors	<u></u>
181) Type	<u></u>
182) Marque Make	<u></u>
183) Modèle Model	<u></u>
184) Nombre de passages de gaz par carburateur Number of mixture passages per carburetor	<u></u>



Marque / Make SAAB Modèle / Model 900 TURBO N° ~~113~~ 45764

- 185) Diamètre de la tubulure de gaz à la sortie du carburateur
Flange hole diameter of exit port of carburettor -
- 186) Diamètre du diffuseur au point d'étranglement maximum
Minimum diameter of venturi -
- Injection (si prévue) (if fitted)
- 187) Marque de la pompe
Make of pump Bosch
- 188) Nombre de pistons
Number of plungers -
- 189) Modèle ou type de la pompe
Model or type of pump Roll cell type
- 190) Nombre total d'injecteurs
Total number of injectors 4
- 191) Emplacement des injecteurs
Location of injectors Inlet manifold
- 192) Diamètre de la pipe d'admission au point de passage le plus étroit
Minimum diameter of inlet pipe 55 mm

ÉQUIPEMENT DU MOTEUR / ENGINE ACCESSORIES

- 195) Pompe à essence - mécanique et/ou électrique
Fuel pump - mechanical and/or electrical Electrical
- 196) Nombre
Number 1
- 197) Type du système d'allumage
Type of ignition system Transistorized with distributor and coil
- 198) Nombre de bobines
Number of ignition coils 1
- 199) Génératrice : type Alternator Nombre
Generator : type 1 Number
- 200) Système d'entraînement
Method of drive Belt
- 201) Batterie / Battery
a) Tension 12 (14) Voltage
b) Emplacement Engine compartment Location
- 205) Arbres à cames / Camshaft



R : Centre

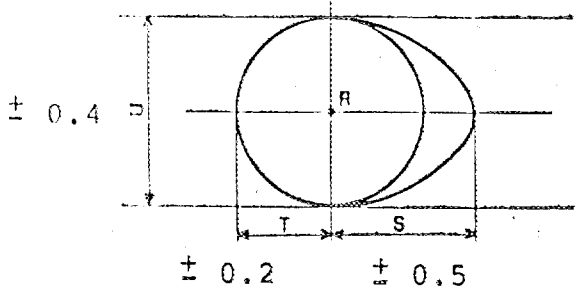

Camé admission Inlet cam	Camé échappement Exhaust cam
S = <u>28.63</u> mm _____ Inches	S = <u>29.83</u> mm _____ Inches
T = <u>19.50</u> mm _____ Inches	T = <u>19.30</u> mm _____ Inches
U = <u>39.06</u> mm _____ Inches	U = <u>39.10</u> mm _____ Inches

Marque / Make SAAB Modèle / Model 900 TURBO N° 5764 P1

TRANSMISSION AUX ROUES / WHEEL DRIVE

Embrayage / clutch

- 210) Type Diaphragm spring
- 211) Diamètre / Diameter 219 mm
- 212) Diamètre des garnitures : intérieur 146 mm extérieur 217 mm
Diameter of linings : interior outside
- 213) Nombre de disques 1
Number of discs

Boîte de vitesses / Gear-box

- 216) Nombre de rapports AV synchronisés 4
Number of forward synchronised ratios
- 216) Emplacement de la commande Floor
Location of the gear lever
- 217) Boîte automatique - emplacement de la commande -
Automatic gear-box - location of gear lever
- 218) Surmultiplication - type -
Overdrive type
- 219) Rapport de surmultiplication -
Overdrive ratio

Pont moteur - Final drive

- 220) Type du pont autobloquant (si prévu) -
Type of limited slip differential (if provided)
- 221) Nombre de dents du couple conique 35 - 9 ou 31 - 6
Number of teeth of final drive or
- 222) Rapport au couple conique 3.89 ou 5.17
Final drive ratio or

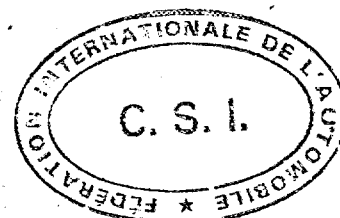

5764 LI

Photo K

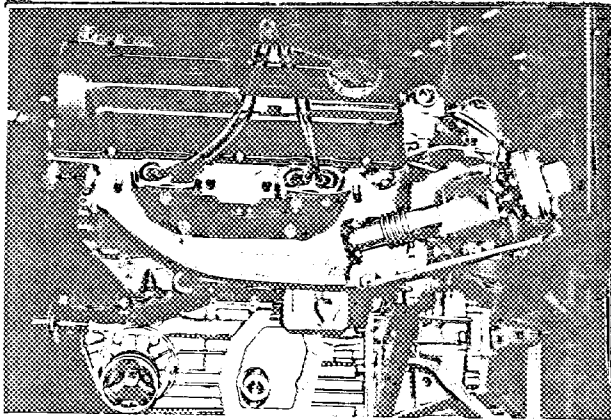

Photo L

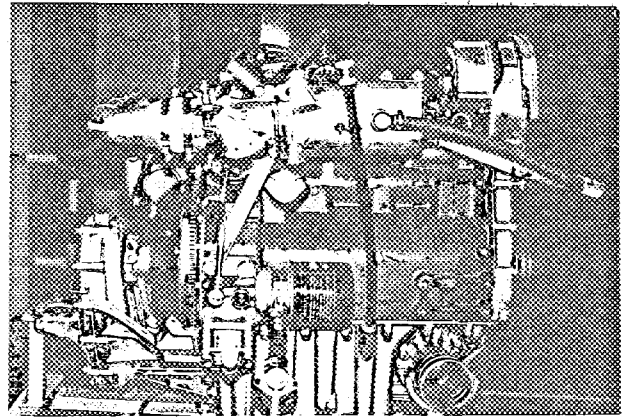

Photo M

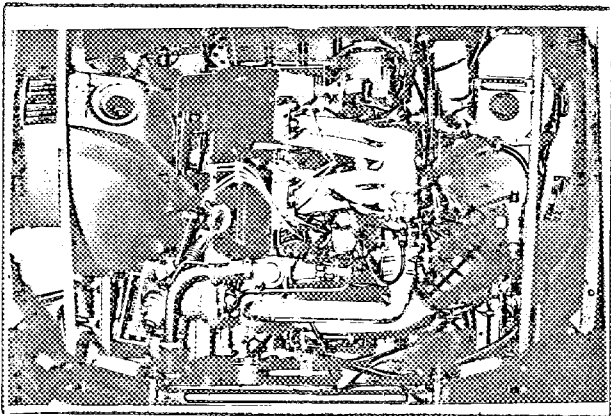

Photo N



Photo P

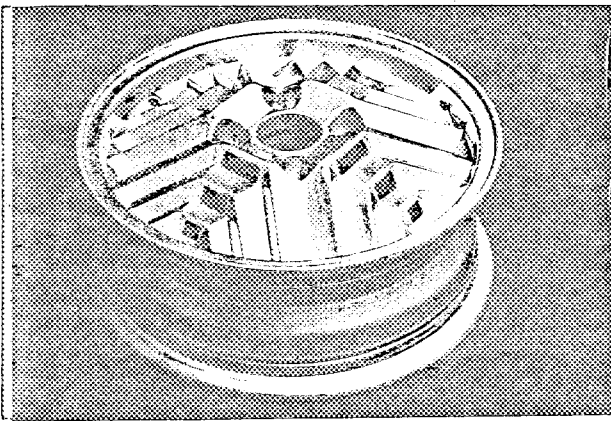

Photo Q

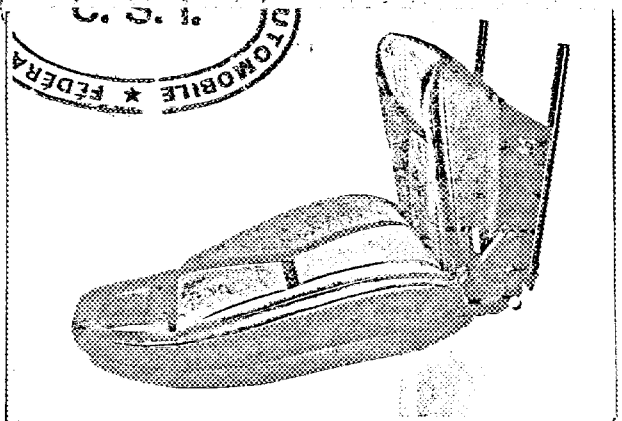

Photo R

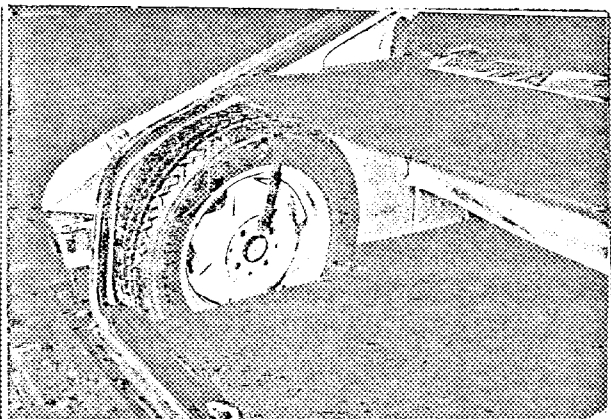
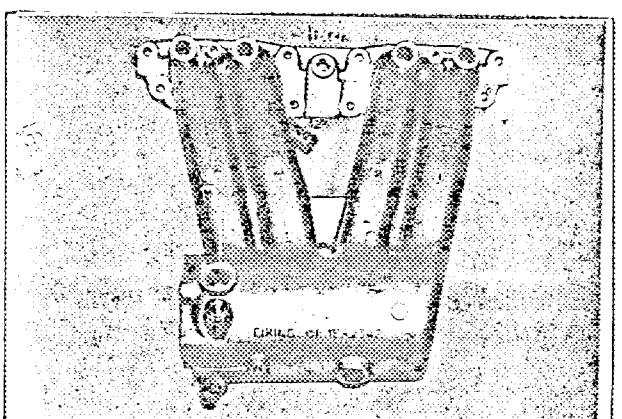

Photo S



Dessin orifices collecteur admission, face côté culasse.

Drawing inlet manifold ports, side of cylinderhead.

avec dimensions
with

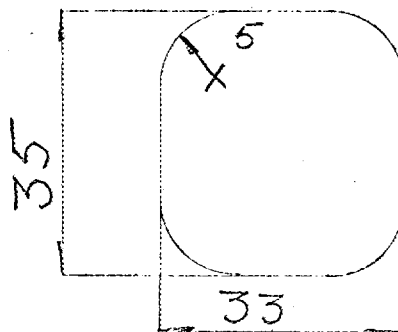

Tolerances as for unfinished castings.
(Ports chamfered 1 mm 30°)

Dessin orifices admission culasse face collecteur.

Drawing of entrance to inlet port of cylinderhead.

avec dimensions
with

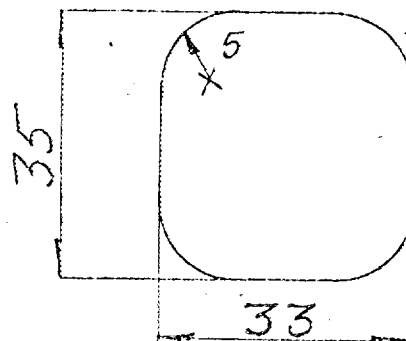

Dessin orifices collecteur échappement face côté culasse.

Drawing of exhaust manifold ports, side of cylinderhead.

avec dimensions
with

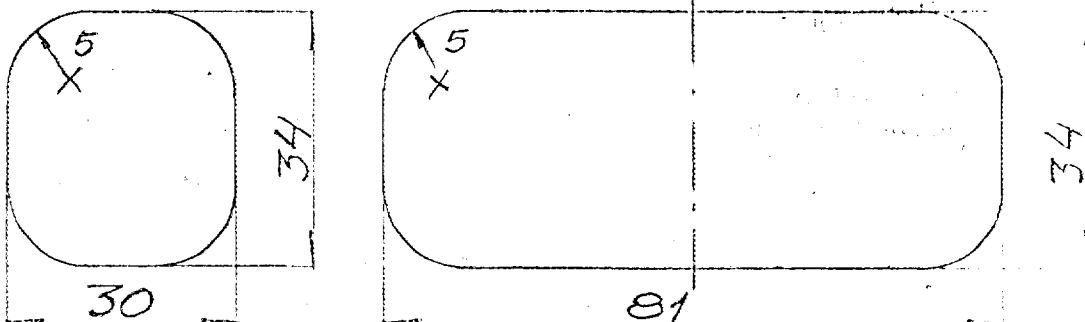

Dessin orifices échappement culasse face collecteur.

Drawing of exit to exhaust port cylinderhead.

avec dimensions
with

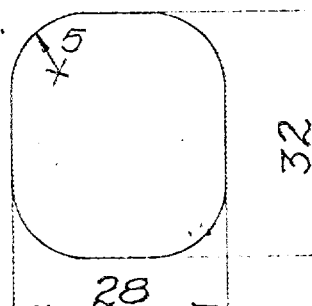

Photo T

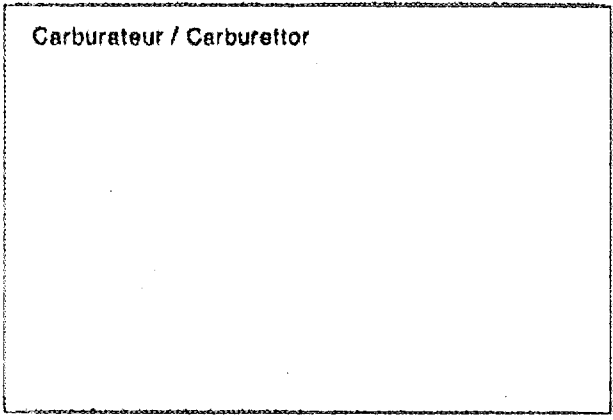

Photo U

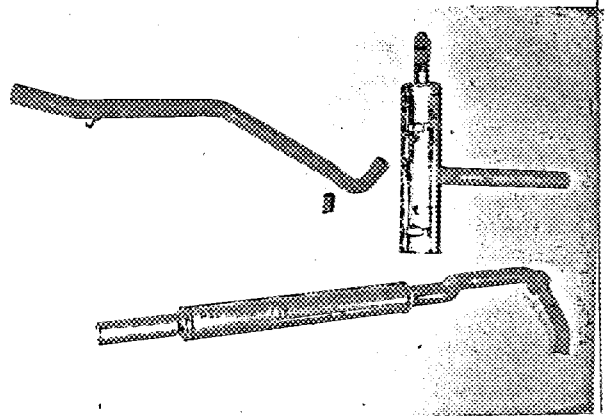
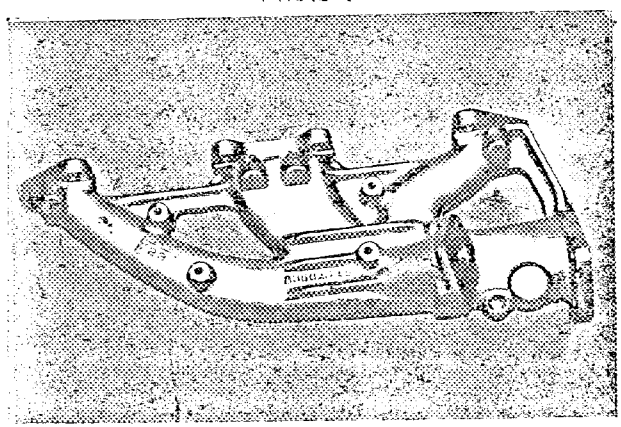

Photo V



Informations supplémentaires
Additional Information

Inlet and exhaust manifolds, ports and ducts machined in series production.

Exit port of exhaust manifold 45 x 57 (radius of corners 10 mm)



Photo W

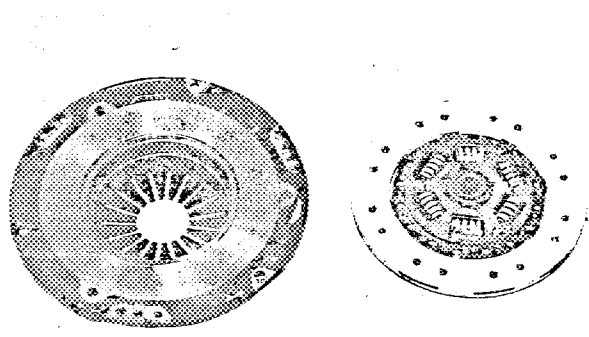

Grille de vitesses
Gear change gate

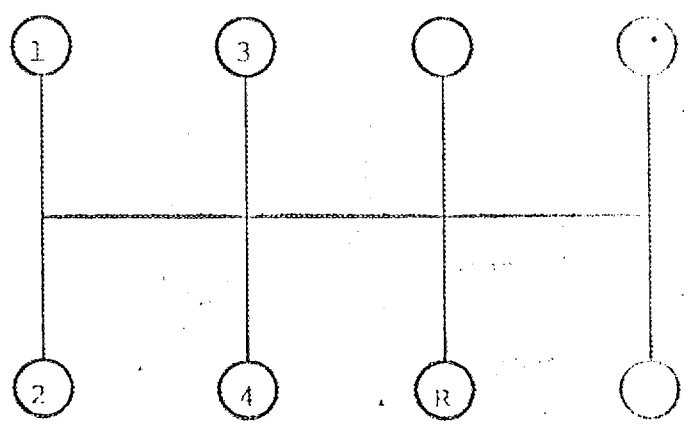

A = Characteristics of turbocharger concerning Group 1

5764

1. TURBOCHARGER (photos 1-4)
 - 1.1 Make and type: Garrett AiResearch
2. TURBINE HOUSING (photo 5)
 - 2.1 Number of exhaust gas entries: One
 - 2.2 Without vanes
 - 2.3 Dimensions of exhaust gas entry: See sketch I
 - 2.4 Dimensions of exhaust gas exit: See sketch II
3. IMPELLER HOUSING
 - 3.1 Dimensions of air intake: See sketch III
 - 3.2 Dimensions of air exit: See sketch IV
4. TURBINE WHEEL (sketch V)
 - 4.1 Maximum outer diameter: 58.9 ±0.5 mm
 - 4.2 Outer diameter at exit of exhaust gas: 45.7 ±0.2 mm
 - 4.3 Height of blade at OD (ref. 4.1/4.2): 4.4/14.6 ±0.5 mm
 - 4.4 Thickness of blade at OD (ref. 4.1/4.2): 1.2/0.6 ±0.4 mm
 - 4.5 Number of blades: 11
5. IMPELLER WHEEL (sketch VI)
 - 5.1 Material: Light alloy
 - 5.2 Maximum outer diameter: 60.2 ±0.5 mm
 - 5.3 Outer diameter at air intake: 37.7 ±0.2
 - 5.4 Height of blade at OD (ref. 5.2/5.3): 0/11.0 ±0.5 mm
 - 5.5 Thickness of blade at OD (ref. 5.2/5.3): 1.0/0.7 ±0.3 mm
 - 5.6 Number of blades: 6+6
6. ADJUSTMENT OF THE PRESSURE (By pass valve - photos 6-7)
 - 6.1 Maximum turbocharging pressure: 0.92 ±0.10 kp/cm² at 3000 rpm measured at pressure switch connection to inlet manifold
 - 6.2 a) Type of valve: Disc Valve
7. EXHAUST SYSTEM (photos U and V)
 - 7.1 Diameter of exhaust pipe at turbocharger connector: 57 mm
 - 7.2 Diameter of exhaust pipe at entry into atmosphere: 51 mm

Make..... SAAB

Model..... 900 TURBO

No. ~~1024~~

5764

1.

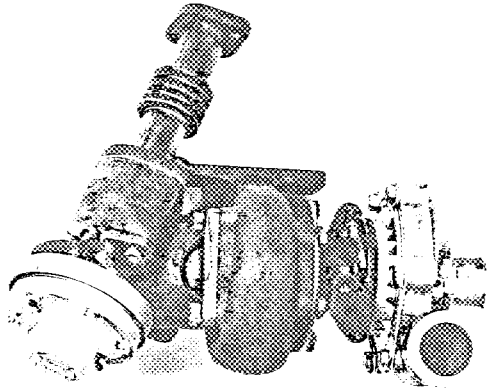

2.

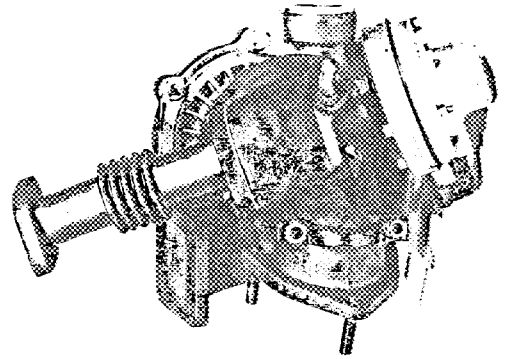

3.

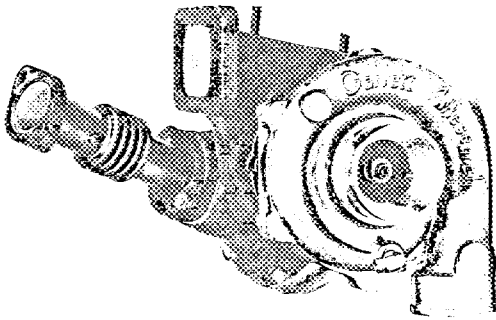

4.

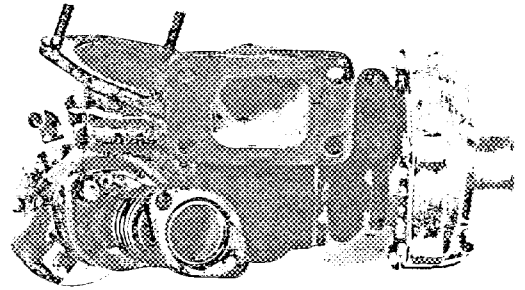

5.

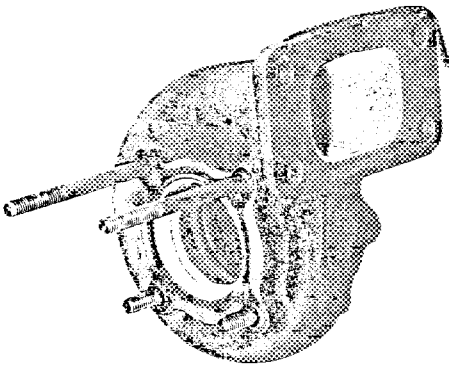

6.

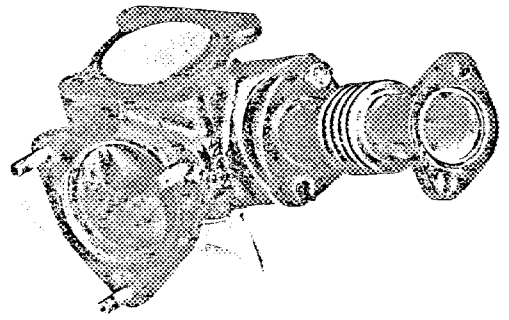

7.

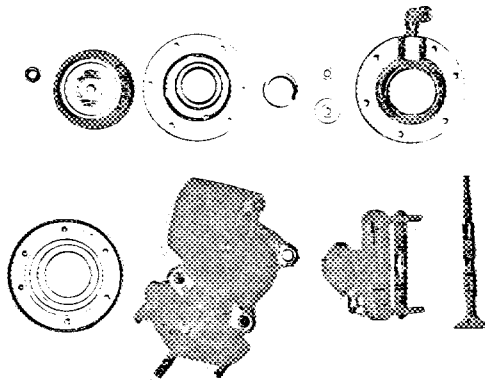

Make

SAAB

Model

900 TURBO

No

~~1554~~

5764

I

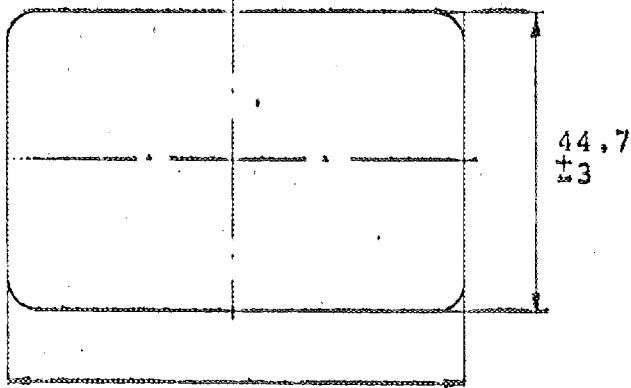

57.2 ± 2

II

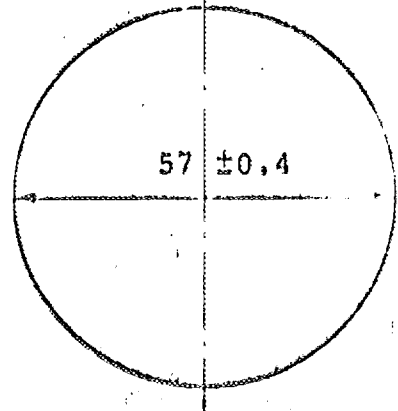

57 ± 0.4

III

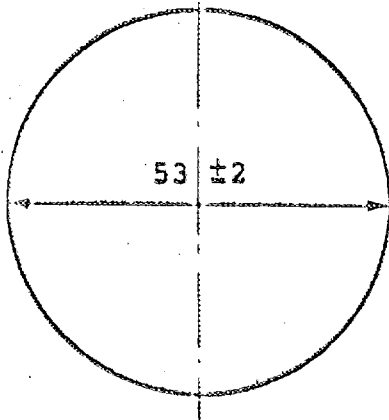

53 ± 2

IV

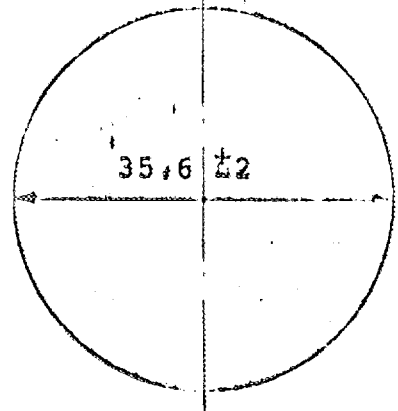

35.6 ± 2



V

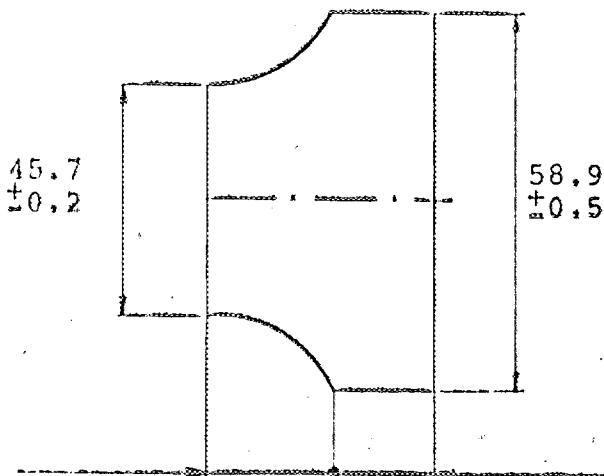

45.7 ± 0.2

58.9 ± 0.5

VI

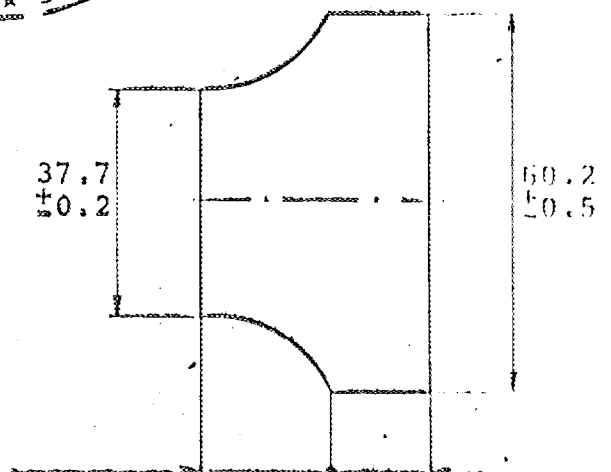

37.7 ± 0.2

60.2 ± 0.5

16.7 ± 0.5

10.0 ± 0.5

14.8 ± 0.5

4.7 ± 0.5

Make..... SAAB

Model..... 900 TURBO

No. ~~1084~~

5764

Turbocharger pressure regulator assy. (93 07 45)

Valve diameter 31 ± 0.3 mm

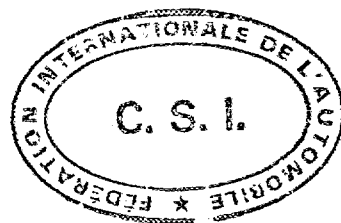
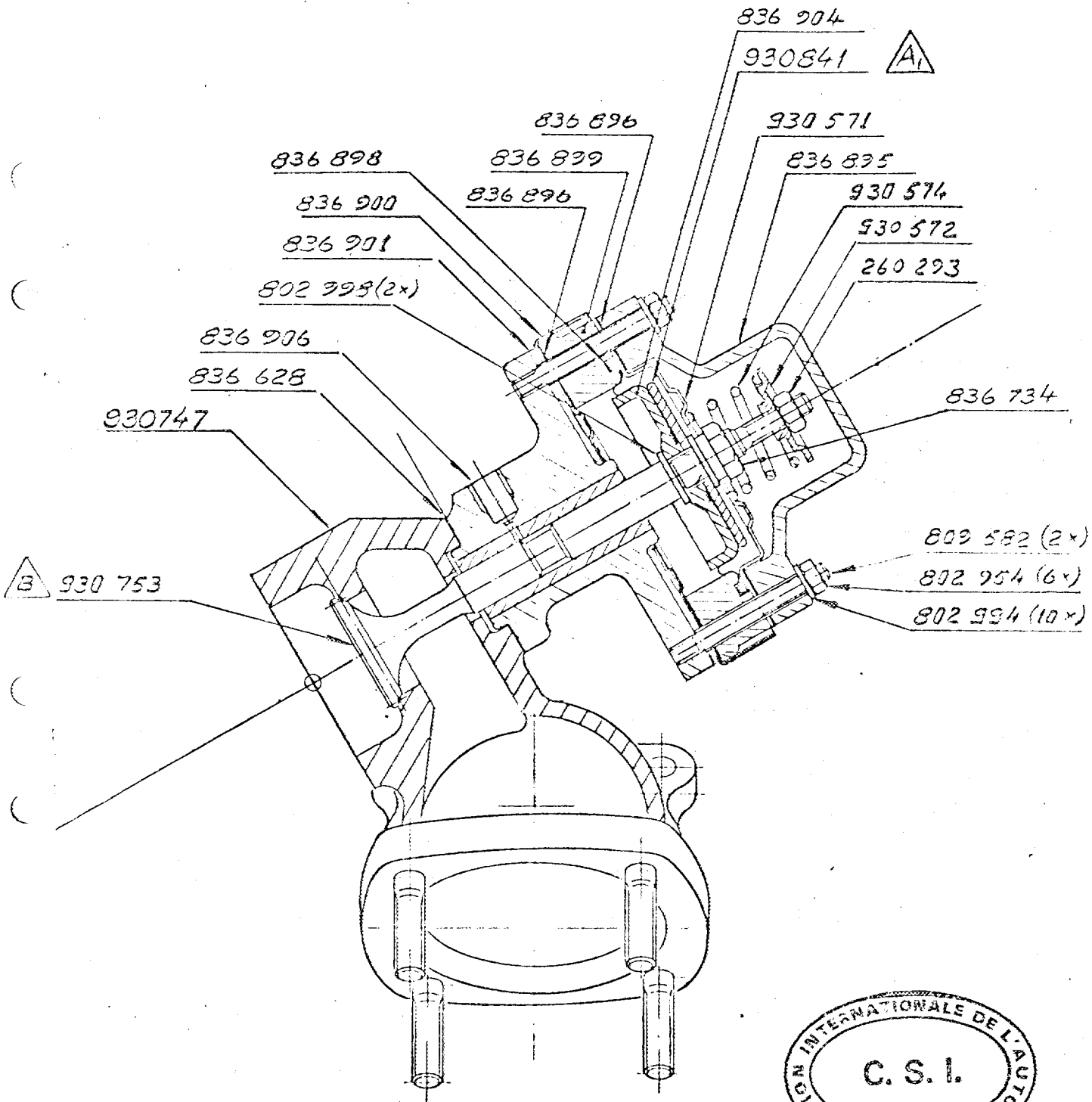

Make SAAB Model 900 TURBO

No ~~1534~~
5764

Turbocharger valve housing assy. (93 06 34)

(tolerances as for unfinished castings)

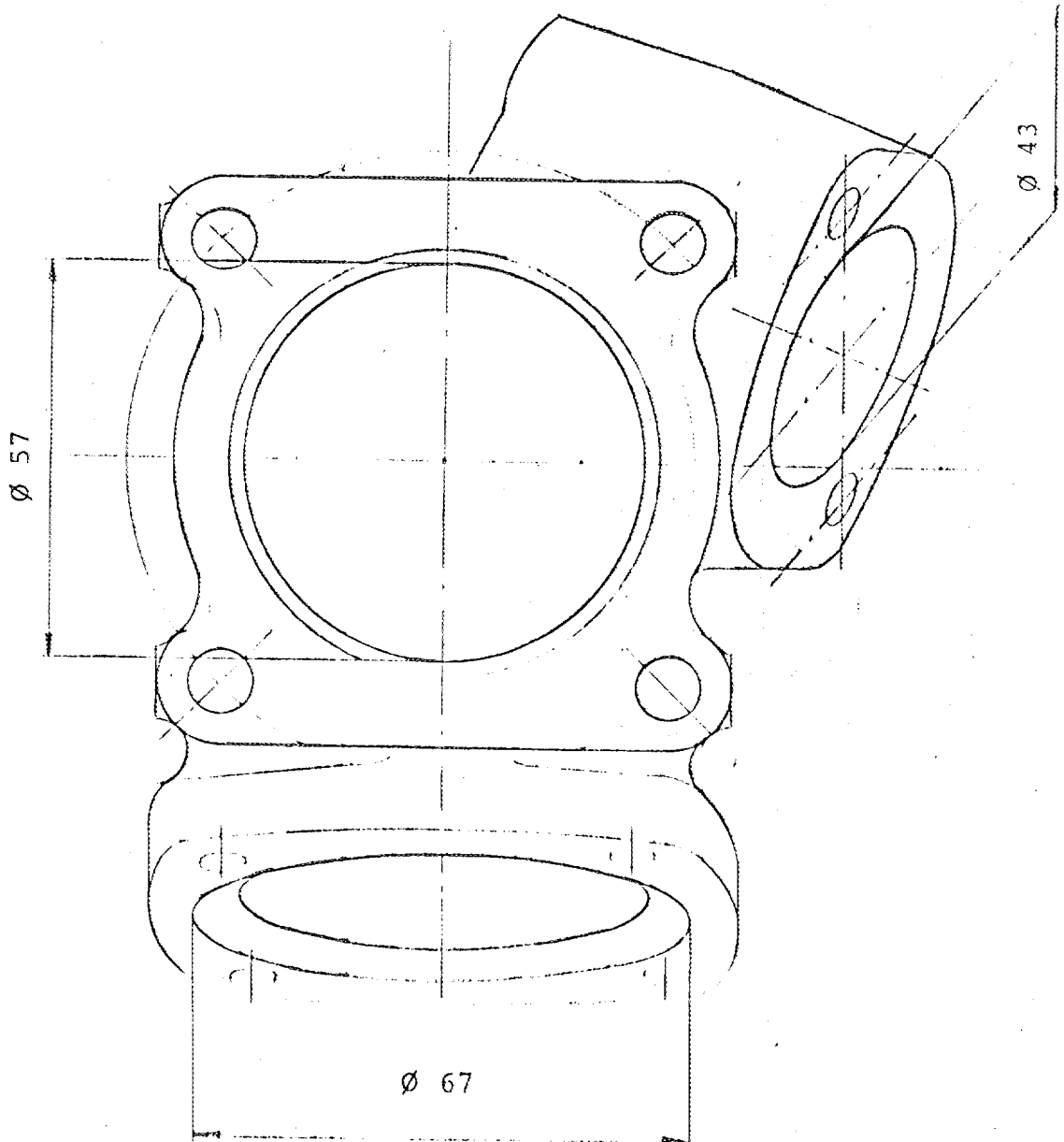

SVENSKA BILSPORTFÖRBUNDET
THE SWEDISH AUTOMOBILE-SPORT FEDERATION

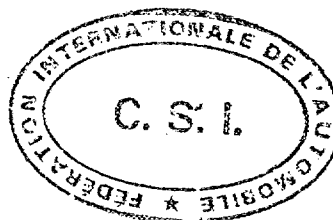

FEDERATION INTERNATIONALE DE L'AUTOMOBILE

Form of recognition (extension) in accordance with
Appendix J to the International Sporting Code.

Manufacturer	SAAB-SCANIA AB	Model	SAAB 900 TURBO
Serial No. inaugurating this extension		Chassis	
Manufacturing date of the first vehicle constructed with the modifications		Engine	
Commercial denomination of modified model			SAAB 900 TURBO
This extension of recognition is considered:			variation - normal development of original vehicle type
Recognition is valid from	-1.FEV.1979	List	

Description of modifications:

- | | |
|------------------------------|------------------------------|
| Strengthened upper wishbone | No 18036 and No 18044 |
| Strengthened lower wishbone | No 18051 and No 18069 |
| Strengthened rear axle | No 18002 (photo E unchanged) |
| Roll bar attachment | (see photo) |
| 4l. Power steering | No 860930 |
| 80. Dry sump lubrication kit | No 18010 (see photos) |

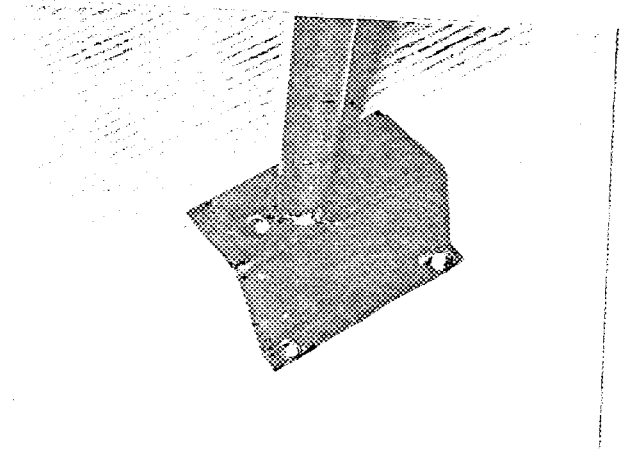
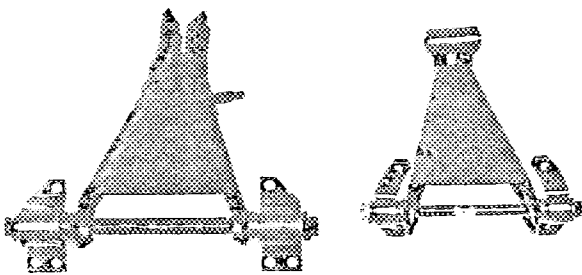

"valable en Groupe 2 uniquement"
"valid for Group 2 only"

Signature and stamp of the
National Sporting Authority:

SVENSKA BILSPORTFÖRBUNDET
THE SWEDISH AUTOMOBILE SPORT FEDERATION

Signature and stamp of the F.I.A.:



FEDERATION INTERNATIONALE DE L'AUTOMOBILE

Form of recognition (extension) in accordance with Appendix J to the International Sporting Code.

Manufacturer	SAAB-SCANIA AB	Model	SAAB 900 TURBO
Serial No. inaugurating this extension		Chassis	
Manufacturing date of the first vehicle constructed with the modifications		Engine	
Commercial denomination of modified model			SAAB 900 TURBO
This extension of recognition is considered:		variation - normal	
		development of original	
		vehicle type	
Recognition is valid from		List	

Description of modifications:

CERTIFICATE

We hereby certify that the structure of the cars (SAAB 900 Turbo and 99 Sedan Turbo), including roll bar (roll cage) in full conformity with the FIA regulation but where the main hoop is connected to the body by the roll bar attachment shown on picture in form 1/IV, complies with the standards required by the FIA for open cars.

Trollhättan, January 9, 1979

SAAB-SCANIA AB
Development and Production Sector
Engineering Department

Henrik Gustavsson
Henrik Gustavsson
Technical Director

"valable en Groupe 2 uniquement"
"valid for Group 2 only"

Signature and stamp of the National Sporting Authority:

SVENSKA BILSPORTFÖRBUNDET
THE SWEDISH AUTOMOBILESPORT FEDERATION

Signature and stamp of the F.I.A.:

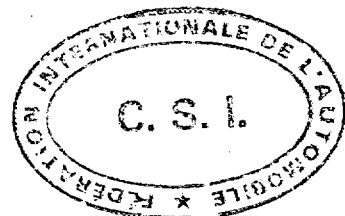

5764

FEDERATION INTERNATIONALE DE L'AUTOMOBILE

Form of recognition (extension) in accordance with Appendix J to the International Sporting Code.

Manufacturer SAAB-SCANIA AB Model SAAB 900 TURBO

Serial No. inaugurating this extension

Chassis

Manufacturing date of the first vehicle constructed with the modifications

Engine

Commercial denomination of modified model SAAB 900 TURBO

This extension of recognition is considered:

variation - ~~development of original vehicle types~~

Recognition is valid from

List

Description of modifications:

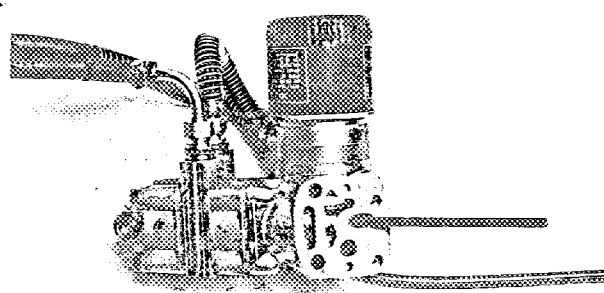

"valable en Groupe 2 uniquement" "valid for Group 2 only"

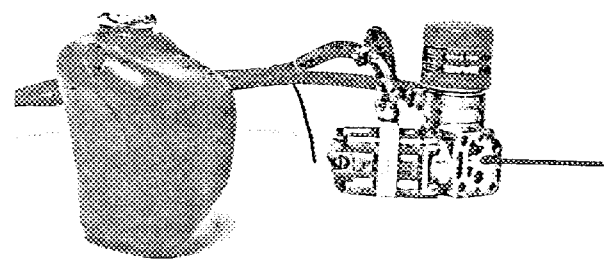

Signature and stamp of the National Sporting Authority:

Signature and stamp of the F.I.A.:

SVENSKA BILSPORTFÖRBUNDET THE SWEDISH AUTOMOBILESPORT FEDERATION

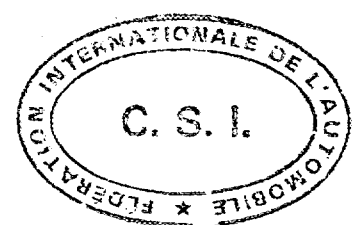

576

FEDERATION INTERNATIONALE DE L'AUTOMOBILE

Form of recognition (extension) in accordance with
Appendix J to the International Sporting Code.

Manufacturer	SAAB-SCANIA AB	Model	SAAB 900 TURBO
		Chassis	
Serial No. inaugurating this extension		Engine	
Manufacturing date of the first vehicle constructed with the modifications			
Commercial denomination of modified model			SAAB 900 TURBO
This extension of recognition is considered:		variation - development of original vehicle type	
Recognition is valid from	-1.FEV.1979	List	

Description of modifications:

"variable en Groupe 2 uniquement"
"valid for Group 2 only"

	Front	Rear
Brakes Teves type	2 L4 34	LC ₁ 33W
93. Number of cylinders per wheel	4	2
94. Bore of wheel cylinders	34 mm	33 mm
100. Outside diameter (ventilated disc)	270 mm	-
101. Thickness of disc	22 mm	-
102. Length of brake linings	77 mm	56 mm
103. Width of brake linings	43 mm	38 mm
104. Number of pads per shoe	2	2
105. Total area per brake	59800 mm ²	54700 mm ²
Pressure limiting valve Teves type BR 18		

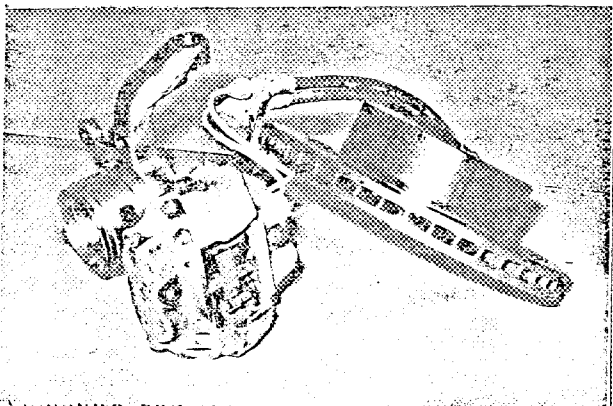

Signature and stamp of the National Sporting Authority:

SVENSKA BILSPORTFÖRBUNDET
THE SWEDISH AUTOMOBILE SPORT FEDERATION

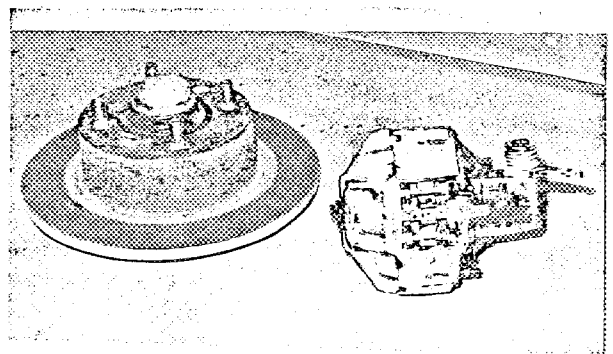

Signature and stamp of the F.I.A.:



[Handwritten signature]

FEDERATION INTERNATIONALE DE L'AUTOMOBILE

Form of recognition (extension) in accordance with Appendix J to the International Sporting Code.

Manufacturer SAAB-SCANIA AB Model SAAB 900 TURBO
 Serial No. inaugurating this extension Chassis
 Manufacturing date of the first vehicle constructed with the modifications Engine
 Commercial denomination of modified model SAAB 900 TURBO
 This extension of recognition is considered: ~~variation -~~ ~~development of~~ ~~original~~ ~~vehicle type~~
 Recognition is valid from -1.Flv.1979 List

Description of modifications:

ROLL CAGE SAAB NO 18028

Material: British Standard 1474 HE 30 (AlSiMgMn)

Tensile strength: 31 kp/mm²

Diameter: 38 mm

Wall thickness: 3.25 mm

Weight: 12 kg

«The manufacturer certifies that car's structure, including the roll-bar, complies with standards required by the FIA for open cars».

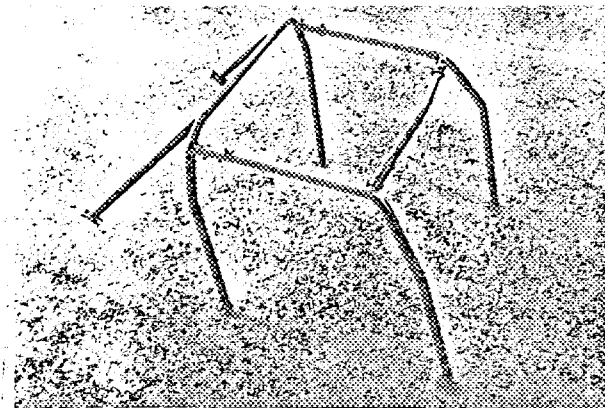

Signature and stamp of the National Sporting Authority:

SVENSKA BILSPORTSFRÖMDEL
THE SWEDISH AUTOMOBILE SPORT FEDERATION

Signature and stamp of the F.I.A.:

