

F.I.A. Recognition No. 576
Group 3- Grand Touring



ROYAL AUTOMOBILE CLUB

31, Belgrave Square, London, S.W.1

Form of recognition in accordance with appendix J to the International Sporting Code of the
FEDERATION INTERNATIONALE DE L'AUTOMOBILE

Cylinder-capacity 2498 cm.³ 152 in.³
Manufacturer STANDARD-TRIUMPH MOTOR CO Model T.R.5.
Serial No. of chassis/body C.D. 1- P ONWARDS Manufacturer STANDARD-TRIUMPH
Serial No. of engine C.P. 1- E ONWARDS Manufacturer STANDARD-TRIUMPH
Recognition is valid from 1st Jan. 1968 List 1968/1
The manufacturing of the model described in this recognition form started on 13-9- 1967
and the minimum production of 500 identical cars, in accordance with the specifications of
this form was reached on 23-11- 1967

Photograph A, 3/4 view of car from front



MAKE TRIUMPH.

MODEL T.R.5.

F.I.A. REG. N°

B



C



D

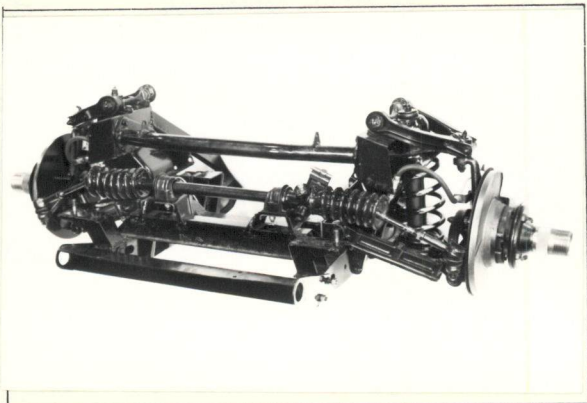

E

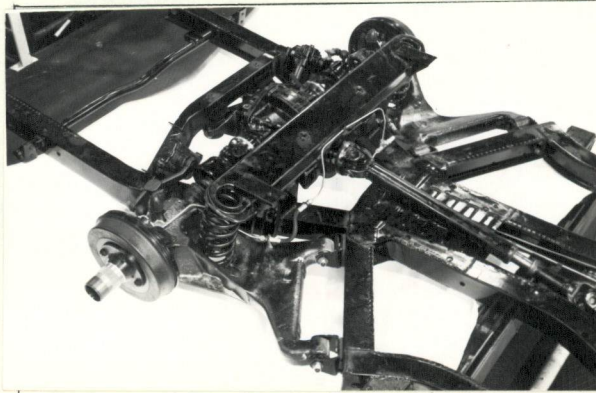

F

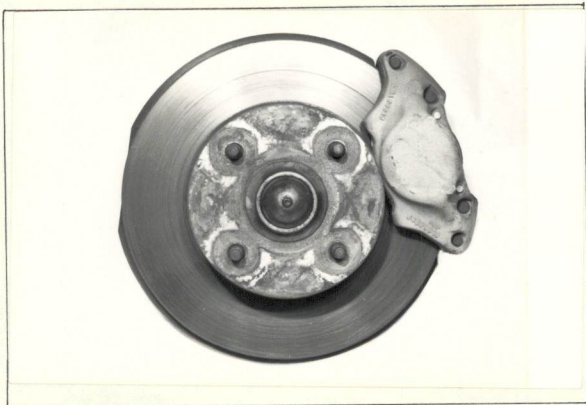

G

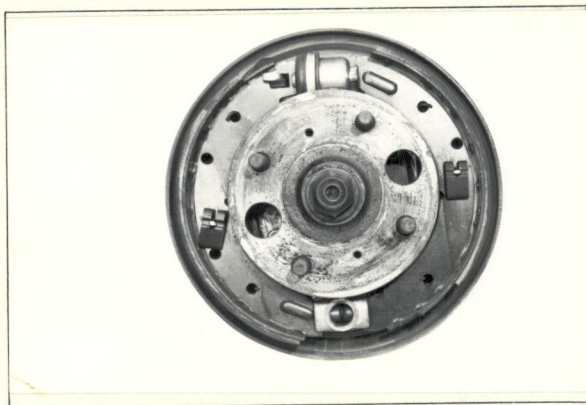

H

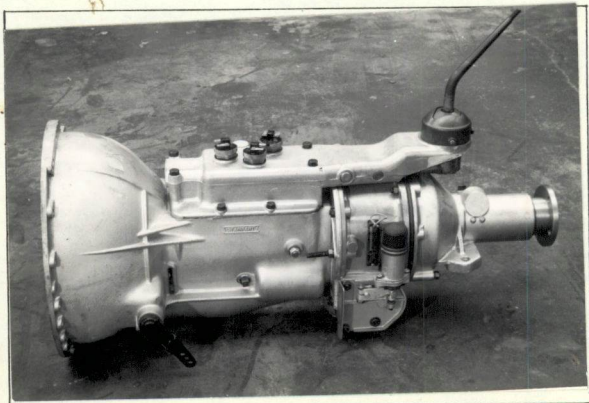

I

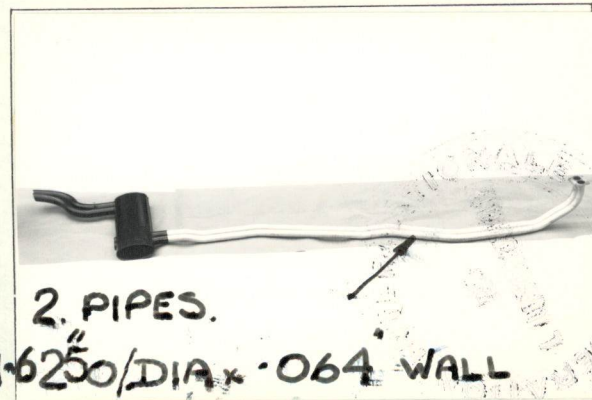

2. PIPES.
1.6250/DIA x .064 WALL
(41.28M/M x 1.63M/M).

MAKE: TRIUMPH

MODEL T.R.5

F.I.A. REC. N°

J

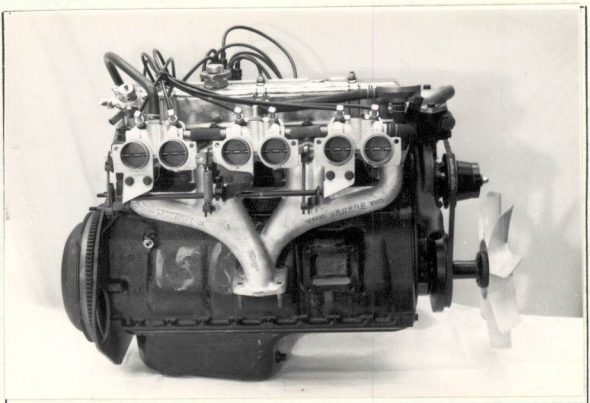

K

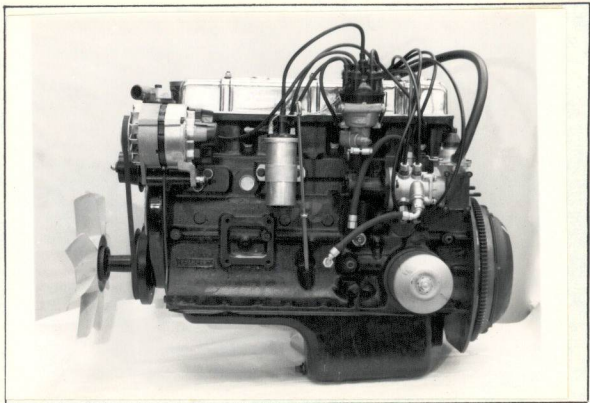

L

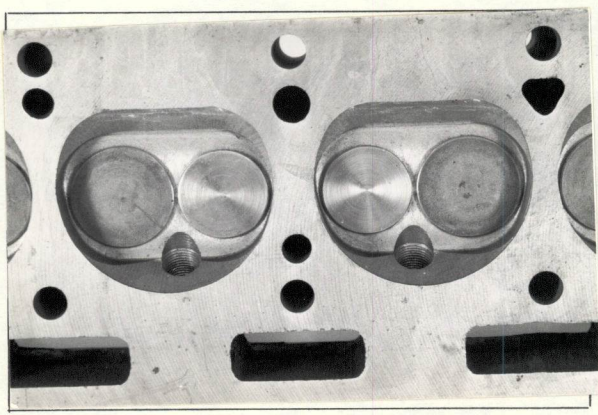

M

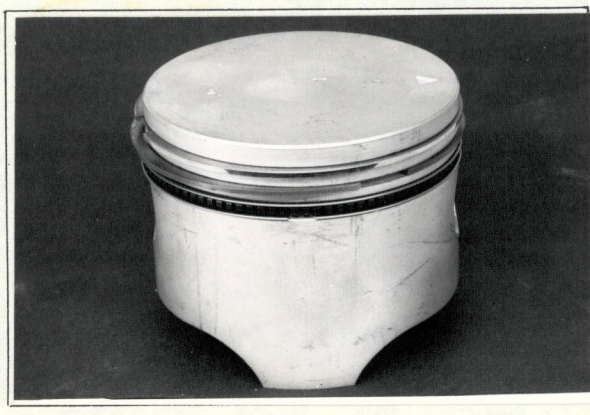

N

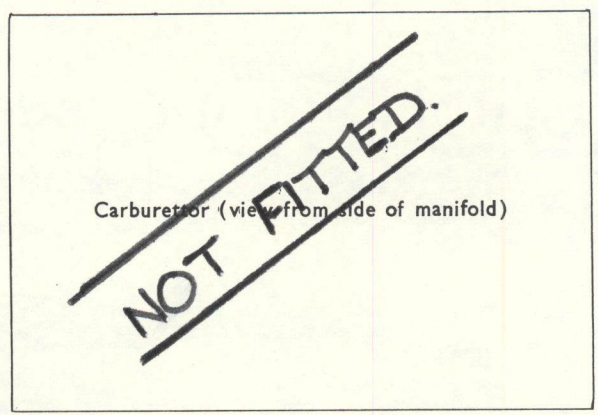

O

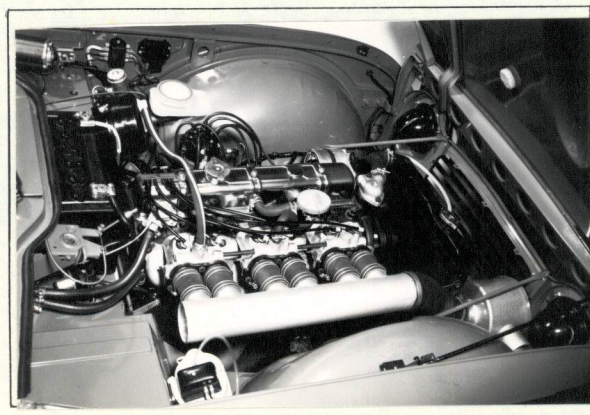

P

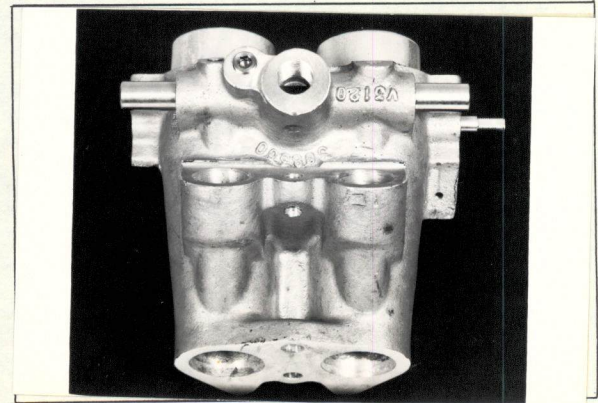

Q

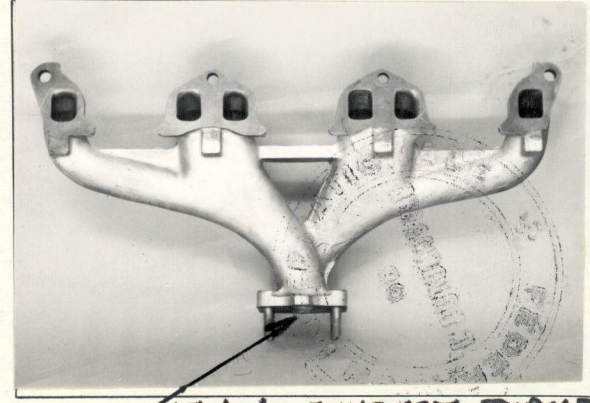

3

TWIN EXHAUST DIAMETERS OF 1.5" (38.1mm).

Drawing inlet manifold ports, side of cylinderhead. Indicate scale or dimensions and manufacturing tolerance.

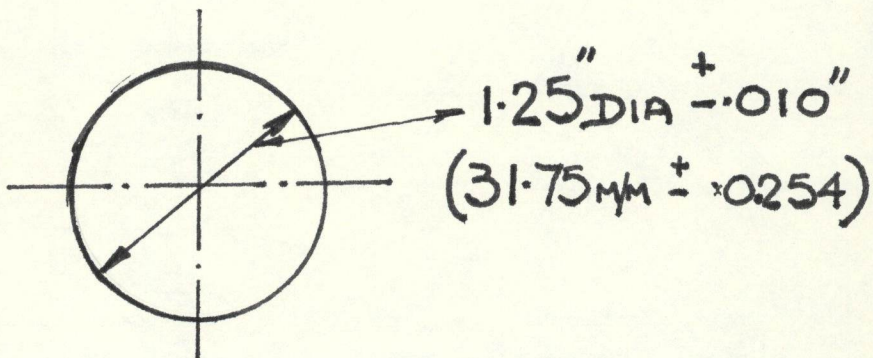

Drawing of entrance to inlet port of cylinderhead. Indicate scale or dimensions and manufacturing tolerance.

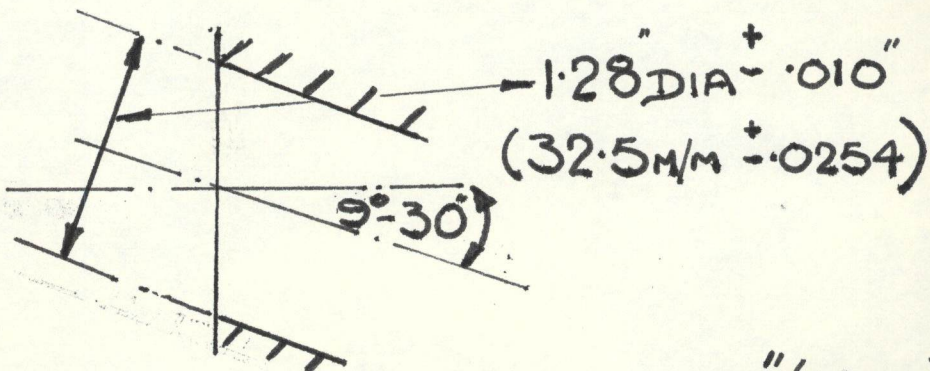

Drawing of exhaust manifold ports, side of cylinderhead. Indicate scale or dimensions and manufacturing tolerance.

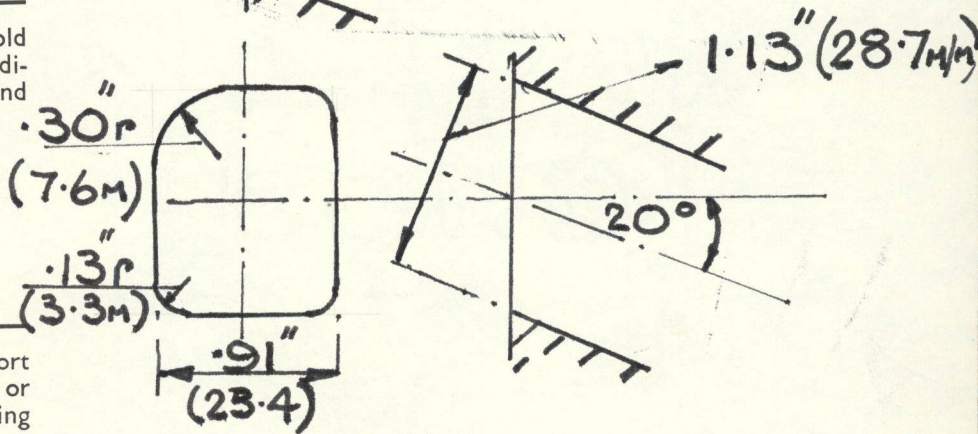

Drawing of exit to exhaust port of cylinderhead. Indicate scale or dimensions and manufacturing tolerance.

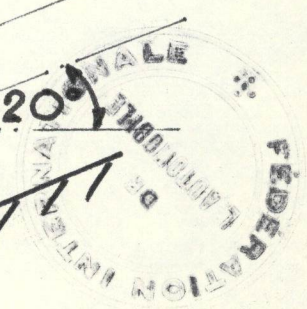
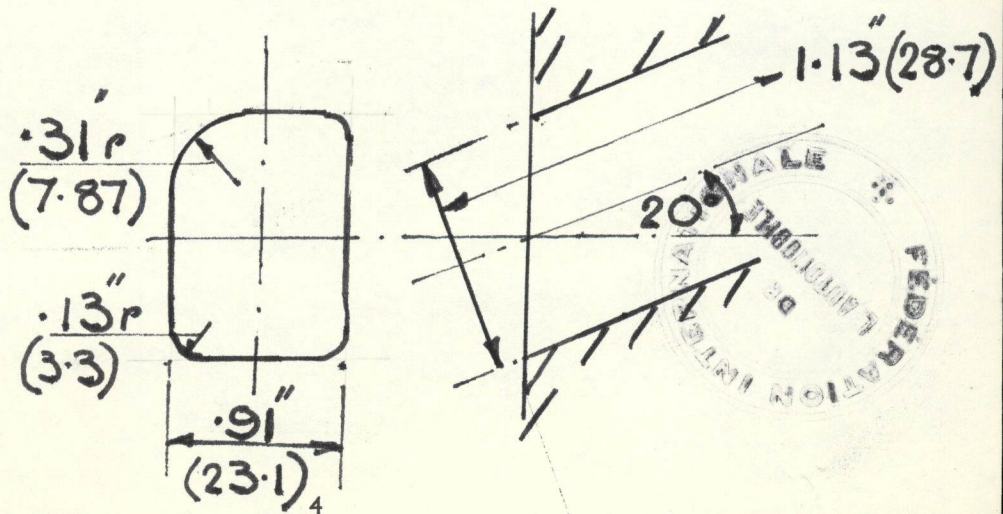

NOTE 1.

All dimensions must be given in two measuring systems, see Note 3.

CAPACITIES AND DIMENSIONS

- 1. Wheelbase 2240 mm. 88 inches
- 2. Front track 3. Rear track

1251 mm. 49.25 inches

1239 mm. 48.75 inches



TRACK TO BE MEASURED WITH WHEELS AT 0° CAMBER

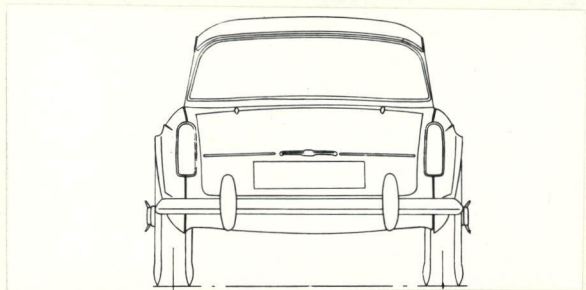

TRACK TO BE MEASURED WITH WHEELS AT 0° CAMBER

- 4. Overall length of the car 390.2 cm. 153.63 inches
- 5. Overall width of the car 147 cm. 58 inches
- 6. Overall height of the car 127 cm. 50 inches
- 7. Capacity of fuel tank (reserve included) 51 ltrs. 13.5 gall. U.S. 11.25 gall. Imp.
- 8. Seating Capacity. **2**
- 9. Weight. Total weight of the car with normal equipment, water, oil, and spare wheel but without fuel or repair tools: 984.13 kg. 2170 lbs. 19.38 cwts.

NOTE 2.

Differences in track caused by the use of other wheels with different rim widths must be stated when recognition is requested for the wheels concerned. Specify ground clearance in relation to the track and give drawing of two easily recognisable points at front and rear at which measurements are taken. These ground clearance dimensions are only for information when checking the track and can in no way affect the eligibility of the car.

NOTE 3.

CONVERSION TABLE

1 inch/pouce	— 2.54	cm.	1 quart US	— 0.9464	ltrs.
1 foot/pied	— 30.4794	cm.	1 pint (pt)	— 0.568	ltrs.
1 sq. inch/pouce carre	— 6.452	cm. ²	1 gallon Imp.	— 4.546	ltrs.
1 cubic inch/pouce cube	— 16.387	cm. ³	1 gallon US	— 3.785	ltrs.
1 pound/livre (lb)	— 453.593	gr.	1 hundred weight (cwt.)	— 50.802	kg.

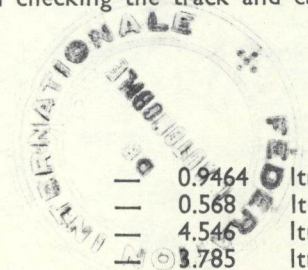

CHASSIS AND COACHWORK (Photographs A, B and C)

- 20. Chassis/body construction: separate/~~unitary construction~~
- 21. Unitary construction, material(s) **N.A.**
- 22. Separate construction, Material(s) of chassis **STEEL**
- 23. Material(s) of coachwork **STEEL**
- 24. Number of doors **2** Material(s) **STEEL**
- 25. Material(s) of bonnet **STEEL**
- 26. Material(s) of boot lid **STEEL**
- 27. Material(s) of rear-window **PLASTIC.**
- 28. Material(s) of windscreen **LAMINATED OR ZONE TOUGHENED GLASS**
- 29. Material(s) of front-door windows **GLASS**
- 30. Material(s) of rear-door windows **N.A.**
- 31. Sliding system of door windows **REMOTE WINDER.**
- 32. Material(s) of rear-quarter light **PLASTIC.**

ACCESSORIES AND UPHOLSTERY

- 38. Interior heating : yes
- 39. Air conditioning : — no **SEPERATE. AMBLA.**
- 40. Ventilation : yes **DASH VENTS**
- 41. Front seats, type of seat and upholstery **SEPERATE. AMBLA.**
- 42. Weight of front seat(s), complete with supports and rails, out of the car :

	10.43	kg.	23	lbs.
--	--------------	-----	-----------	------
- 43. Rear seats, type of seat and upholstery **N.A.**
- 44. Front bumper, material(s) **STEEL** Weight **5.44** kg. **12** lbs.
- 45. Rear bumper, material(s) **STEEL** Weight **8.05** kg. **17 3/4** lbs.

WHEELS

- 50. Type **STEEL DISC.**
- 51. Weight (per wheel, without tyre) **7.71** kg. **17** lbs.
- 52. Method of attachment **4 NUT FIXING**
- 53. Rim diameter **381** mm. **15** ins.
- 54. Rim width **114.3** mm.

STEERING

- 60. Type **RACK & PINION**
- 61. Servo-assistance : — no
- 62. Number of turns of steering wheel from lock to lock **3 1/4**
- 63. In case of servo-assistance **N.A.**

SEE OPTIONS

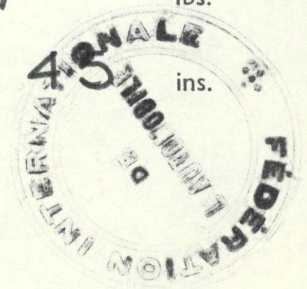

Make TRIUMPH

Model TR5.

F.I.A. Rec. No.

SUSPENSION

- 70. Front suspension (photograph D), type INDEPENDANT. DOUBLE WISHBONE.
- 71. Type of spring COIL.
- 72. Stabiliser (if fitted) -
- 73. Number of shock absorbers 1 PER SIDE 74. Type TELESCOPIC.
- 78. Rear suspension (photograph E), type INDEPENDANT. SEMI-TRAILING ARMS.
- 79. Type of spring COIL
- 80. Stabiliser (if fitted) -
- 81. Number of shock absorbers 1 PER SIDE 82. Type LEVEL-ARM. PISTON.

BRAKES (photographs F and G)

- 90. Method of operation HYDRAULIC.
- 91. Servo-assistance (if fitted), type DIRECT ACTING SERVO
- 92. Number of hydraulic master cylinders 1 (TANDEM TYPE.)
- 93. Number of cylinders per wheel 2 FRONT 1 REAR
- 94. Bore of wheel cylinder(s) 53.9 mm 2.125 inches | 17.8 mm. .7 inches

Drum Brakes

- 95. Inside diameter mm. inches 228.6 mm. 9 inches
- 96. Length of brake linings mm. inches 219.5 mm. 8.64 inches
- 97. Width of brake linings mm. inches 44.5 mm. 1.75 inches
- 98. Number of shoes per brake 2
- 99. Total area per brake mm.² sq. in. 19516 mm.² 3025 sq. in.

Disc Brakes

- 100. Outside diameter mm. inches 275.0 mm. 10.82 inches
- 101. Thickness of disc mm. inches 12.83 mm. .5 inches
- 102. Length of brake linings mm. inches 67.82 mm. 2.63 inches
- 103. Width of brake linings mm. inches 52.32 mm. 2.07 inches
- 104. Number of pads per brake 2
- 105. Total area per brake mm.² sq. in. 7097 mm.² 11 sq. in.

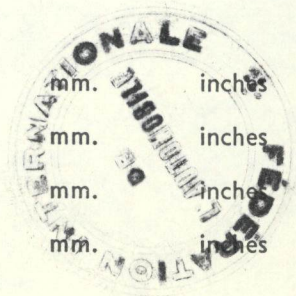

FOUR STROKE ENGINES

170. Number of camshafts 1 171. Location SIDE OF CYL BLOCK.
 172. Type of camshaft drive CHAIN.
 173. Type of valve operation O.H.V. BY PUSHROD.

INLET (see page 4)*

180. Material(s) of inlet manifold ALUM ALLOY
 181. Diameter of valves 36.7 } mm. 1.445 } ins.
36.6 }
 182. Max. valve lift 9.30 mm. .366 in. 183. Number of valve springs 2
 184. Type of spring COIL 185. Number of valves per cylinder 1
 186. Tappet clearance for checking timing (cold) .38 mm. .015 ins.
 187. Valves open at (with tolerance for tappet clearance indicated) 35° B.T.D.C.
 188. Valves close at (with tolerance for tappet clearance indicated) 65° A.B.D.C.
 189. Air filter, type PAPER ELEMENT.

EXHAUST (see page 4)*

195. Material(s) of exhaust manifold CAST IRON.
 196. Diameter of valves 32.0 } mm. 1.260 } ins.
31.9 }
 197. Max. valve lift 9.30 mm. .366 in. 198. Number of valve springs 2
 199. Type of spring COIL 200. Number of valves per cylinder 1
 201. Tappet clearance for checking timing (cold) .38 mm. .015 ins.
 202. Valves open at (with tolerance for tappet clearance indicated) 65° B.B.D.C.
 203. Valves close at (with tolerance for tappet clearance indicated) 35° A.T.D.C.

CARBURETION (photograph N)

210. Number of carburettors fitted _____
 212. Make _____ 213. Model _____
 214. Number of mixture passages per carburettor _____
 215. Flange hole diameter of exit port(s) of carburettor mm. ins.
 216. Minimum diameter of venturi/minimum diam., with piston at maximum height (example : SU) mm. ins.

INJECTION (if fitted)

220. Make of pump LUCAS 221. Number of plungers SHUTTLES.
 222. Model or type of pump 730-59 223. Total number of injectors 6
 224. Location of injectors TOP OF INLET MANIFOLD. BETWEEN THROTTLE & HEAD.
 225. Minimum diameter of inlet pipe 31.75 mm. 1.25 ins.

* For additional information concerning two-stroke engines and super-charged engines, see page 13.

Make TRIUMPH

Model T.R.5

F.I.A. Rec. No.

ENGINE ACCESSORIES

- 230. Fuel pump : ~~mechanical~~ electrical
- 231. No. fitted **1**
- 232. Type of ignition system **COIL**
- 233. No. of distributors **1**
- 234. No. of ignition coils **1**
- 235. No. of spark plugs per cylinder **1**
- 236. Generator, type : ~~generator~~/alternator—number fitted **1**
- 237. Method of drive **VEE-BELT**
- 238. Voltage of generator **12** volts
- 239. Battery, number **1**
- 240. Location **UNDER BONNET**
- 241. Voltage of battery **12** volts **57 AMP/HOUR.**

ENGINE AND CAR PERFORMANCES (as declared by manufacturer in catalogue)

- 250. Max. engine output **150** (type of horsepower: **B.H.P.**) at **5,500** r.p.m.
- 251. Max. r.p.m. **NOT QUOTED** output at that figure
- 252. Max. torque **1970 LBS/INS.** at **3,500** r.p.m.
- 253. Max. speed of the car **200** km./hour **125** miles/hour

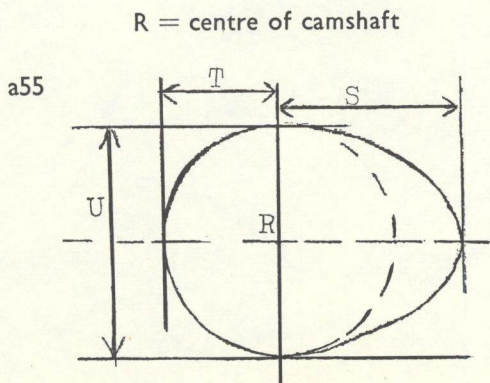

Inlet cam

S = **20.17** mm. **.794** inches
 T = **13.72** mm. **.540** inches
 U = **27.43** mm. **1.080** inches

Exhaust cam

S = **20.17** mm. **.794** inches
 T = **13.72** mm. **.540** inches
 U = **27.43** mm. **1.080** inches

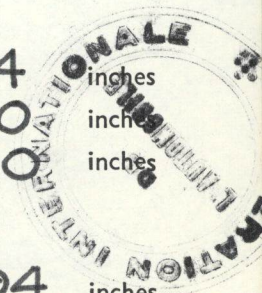

Make TRIUMPH

Model T.R.5.

F.I.A. Rec. No. _____

DRIVE TRAIN

CLUTCH

260. Type of clutch SPRING DIAPHRAGM. 261. No. of plates 1
262. Dia. of clutch plates 21.59 cm. 8.5 ins.
263. Dia. of linings, inside 14.60 cm. 5.75 ins.
- outside 21.59 cm. 8.5 ins.
264. Method of operating clutch HYDRAULIC.

GEAR BOX (photograph H)

270. Manual type, make STANDARD-TRIUMPH Method of operation REMOTE LEVER
271. No. of gear-box ratios forward 4 272. Synchronized forward ratios 4
273. Location of gear-shift CENTRE TUNNEL.
274. Automatic, make _____ type _____
275. No. of forward ratios _____ 276. Location of gear shift _____

277.	Manual		Automatic		Alternative manual/automatic			
	Ratio	No. teeth	Ratio	No. teeth	Ratio	No. teeth	Ratio	No. teeth
1	3.14	33/16.	CONSTANT 35/23					
2	2.01	33/25						
3	1.33	27/31						
4	1.00	DIRECT.						
5								
6								
reverse	3.22	36/17.						

278. Overdrive, type LAYCOCK-DE-NORMANVILLE TYPE 'A'
279. Forward gears on which overdrive can be selected 3rd & TOP GEAR. OR. 2ND, 3rd & TOP.
280. Overdrive ratio 0.82 / 1

FINAL DRIVE

290. Type of final drive HYPOID.
291. Type of differential BEVEL GEARS.
292. Type of limited slip differential (if fitted) (SEE OPTIONS.)
293. Final drive ratio 3.45 & 3.7. Number of teeth 11x38 & 10x37

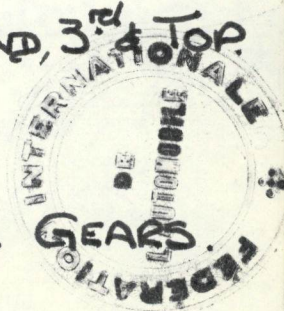

Make **TRIUMPH**

Model **T.R.5.**

F.I.A. Rec. No.

IMPORTANT—The conformity of the car with the following items of the present recognition form is to be disregarded during the scrutineering, when the vehicle has been entered in group 2 (Touring cars) or 3 (Grand Touring cars) : 41, 72, 80, 91, 142, 143, 144, 145, 146, 153, 156, 157, 160, 161, 162, 163, 164, 182, 186, 187, 188, 189, 201, 202, 203, 212, 213, 215, 216 222, 225, 230, 250, 251, 252, 253, 255 photographs I, M and N and page 4.

During the scrutineering of cars entered in group 4 (Sportscars) only the following items of the present recognition form are to be taken into consideration : 1, 2, 3, 9, 20, 21, 22, 23, 24, 25, 26, 70, 71, 78, 79, 90, 130, 131, 132, 133, 134, 135, 136, 137, 138, 139, 140, 141, 147, 148, 149, 150, 158, 159, 170, 171, 172, 173, 185, 200, 270, 271, 274, 275, 290, 291, 292 and photographs A, B, D, E, F, G, H, J, K and O.

The vehicle described in this form has been subject to the following amendments :

on.....19.....	rec. no.....	List.....	on.....19.....	rec. no.....	List.....
on.....19.....	rec. no.....	List.....	on.....19.....	rec. no.....	List.....
on.....19.....	rec. no.....	List.....	on.....19.....	rec. no.....	List.....
on.....19.....	rec. no.....	List.....	on.....19.....	rec. no.....	List.....
on.....19.....	rec. no.....	List.....	on.....19.....	rec. no.....	List.....

Optional equipment affecting preceding information. This to be stated together with reference number.

HARDTOP CONVERSION.

DET N° 903948

VEHICLE WEIGHT PAGE 5 SEC 9

993.82 KGS. 2191. LBS 19.5 CWTs.

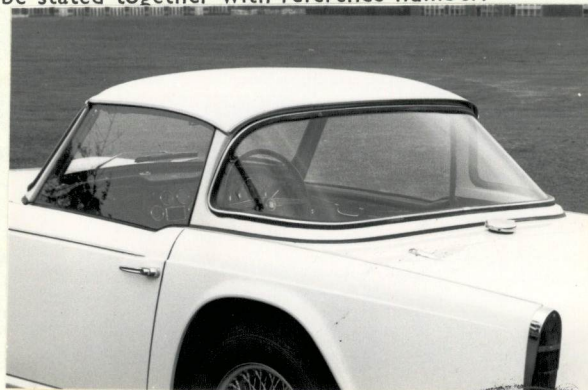

- 292. LIMITED SLIP DIFFERENTIAL (FRICTION) DET N° 212978
- 293. FINAL DRIVE RATIO. 4.1 TO 1 (N° TEETH 10/41) DET N° 505014
- --- --- --- 4.3 TO 1 (N° TEETH 10/43) DET N° 502523.
- --- --- --- 4.5 TO 1 (N° TEETH 9/41) DET N° 503924
- --- --- --- 4.87 TO 1 (N° TEETH 8/39) DET N° 515844.



SKID-SHIELD ASSEMBLY.
DET N° 308208.

WEIGHT. 9.07KGS ~ 20LBS.

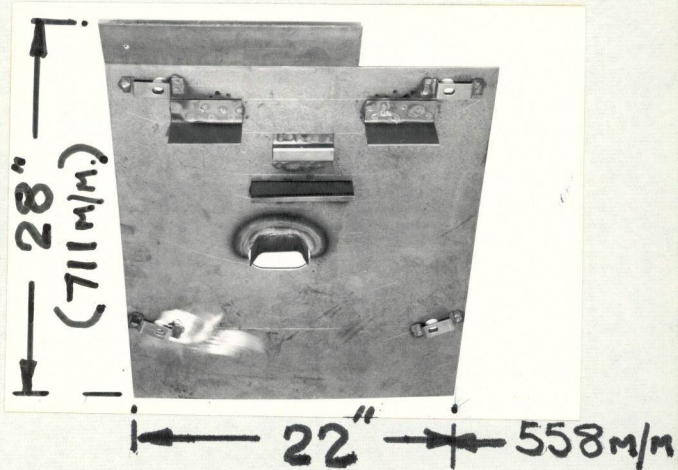

PAGE 6 WHEELS (ALTERNATIVES). DET N° 204101

50. TYPE 60SPOKE WIRE.

51 WEIGHT 7.48KGMS ~ 16.5 LBS.

52 METHOD OF ATTACHMENT. CENTRE LOCK.

53 RIM. DIA. 381MM 15INS. 54 RIM WIDTH. 114.3MM. 4.5INS.

TRACK INCREASE TO 1263MM } FRONT. 1251MM } REAR.
49.75INS. } 49.25INS. }

PAGE 5. SEC7

INCREASED CAPACITY FUEL TANK. DET N° 308500.

CAPACITY. 79.55LTRS. 21. GALL U.S 17.5 GALL IMP

PAGE 6. WHEELS

50. TYPE:- LIGHT ALLOY. (DET N° 2D/351)

51. WEIGHT:- 6.35KGS ~ 14LBS

52 METHOD OF ATTACHMENT:- 4NUT FIXING.

53 RIM DIA:- 381MM ~ 15INS

54. RIM WIDTH:- 139.7MM ~ 5.5INS.

TRACK INCREASE TO 1245 MM } FRONT
DECREASE 49.0 INS. }
P.10.9.

1232 MM } REAR.
48.5 INS. }

