



JAPAN AUTOMOBILE FEDERATION

F. I. A. Recognition No. **566**

Group **3 - Grand Touring**

FEDERATION INTERNATIONALE DE L'AUTOMOBILE

Form of recognition in accordance with Appendix J to the International Sporting Code.

Manufacturer: **NISSAN MOTOR CO., LTD.** Cylinder-capacity: **1,982 cm³ 121 cu. in.**
 Model: **SR(L)311**
 Serial No. of chassis: **00001** Manufacturer: **NISSAN**
 Serial No. of engine: **U20-00101** Manufacturer: **NISSAN**
 Recognition is valid from: **1st July 1967** List: **16/4**
 The manufacturing of the model described in this recognition form was started on **Dec. 1966** and the minimum production of **500** identical cars, in accordance with the specifications of this form was reached on **Mar. 1967**

Photograph A, 3/4 view of car from front

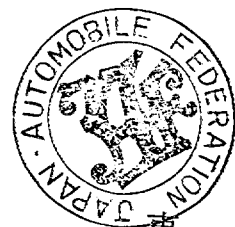
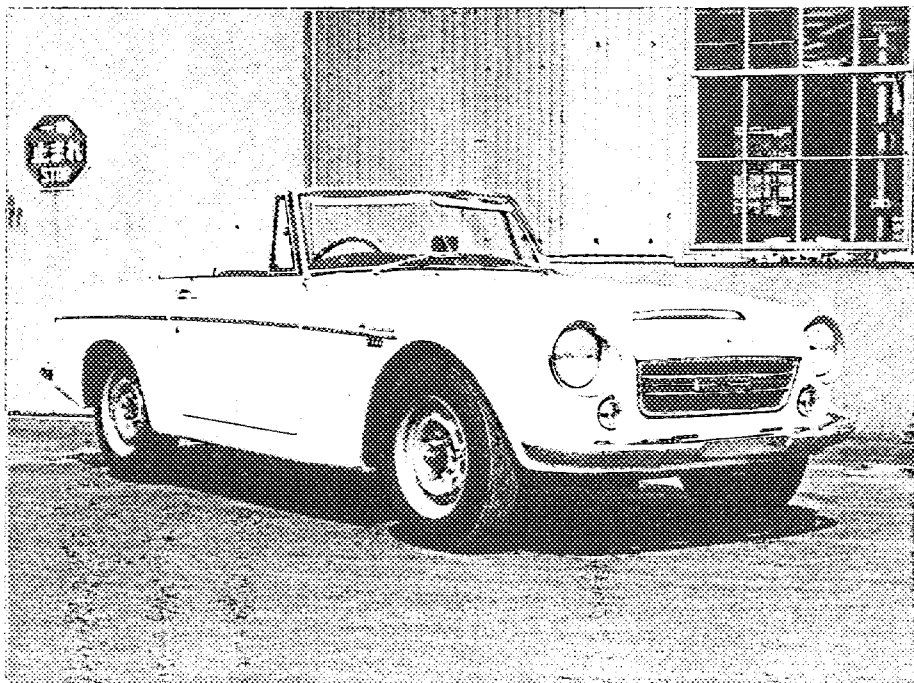

東京都港区芝公園第三号地一番五
 機械振興会館内
 法人 日本自動車連盟

The vehicle described in this form has been subject to the following amendments:

Variants				Normal evolution of the type			
on	19	rec. No.	List	on	19	rec. No.	List
on	19	rec. No.	List	on	19	rec. No.	List
on	19	rec. No.	List	on	19	rec. No.	List
on	19	rec. No.	List	on	19	rec. No.	List
on	19	rec. No.	List	on	19	rec. No.	List

Stamp and signature of the National Sporting Authority

Stamp and signature of the F. I. A.

[Handwritten signature]

Make

NISSAN

Model

SR(L)311

F. I. A. Rec. No.

IMPORTANT - the underlined items must be stated in two measuring systems, one of which must be the metric system. See conversion table hereafter.

CAPACITIES AND DIMENSIONS

1. <u>Wheelbase</u>	2,280	mm	89.76	inches
2. <u>Front track</u>	1,275	mm	50.3	inches *
3. <u>Rear track</u>	1,200	mm	47.3	inches *
4. Overall length of the car		391.0	cm	inches
5. Overall width of the car		149.5	cm	inches
6. Overall height of the car		130.0	cm	inches
7. <u>Capacity of fuel tank</u> (reserve included)			43	ltrs
	11.4	Gallon US		Gallon Imp.
8. Seating capacity	2			
9. <u>Weight</u> , total weight of the car with normal equipment, water, oil and spare wheel but without fuel nor repair tools:				
	890	kg	1,962	lbs
				cwt

* Differences in track caused by the use of other wheels with different rim widths must be stated when recognition is requested for the wheels concerned.

Specify ground clearance in relation to the track and give drawing of two fixed points of the vehicle's structure at which measurements are taken.

These ground clearance dimensions are only for information when checking the track and can in no way affect the eligibility of the car.

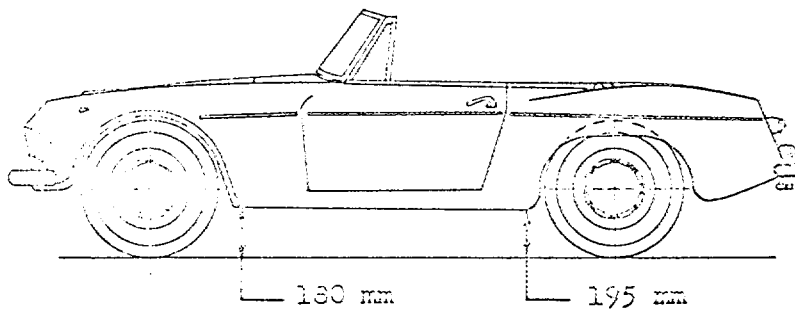

CONVERSION TABLE

1 inch/pouce	-- 2.54 cm	1 quart US	-- 0.9464 ltrs
1 foot/pied	-- 30.4799 cm	1 pint (pt)	-- 0.568 ltrs
1 square inch/pouce carré	-- 6.452 cm ²	1 gallon imp.	-- 4.546 ltrs
1 cubic inch/pouce cube	-- 16.387 cm ³	1 gallon US	-- 3.785 ltrs
1 pound/livre (lb)	-- 453.593 gr.	1 hundred weight (cwt)	-- 50.802 kg

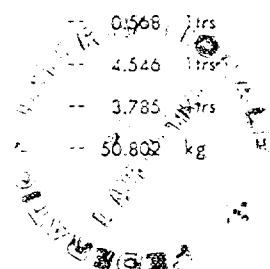

Make

NISSAN

Model

SR(L)311

F. I. A. Rec. No.

SUSPENSION

- 70. Front suspension (photogr. D), type Independent by coil spring and wishbone
- 71. Type of spring Coil
- 72. Stabiliser (if fitted)
- 73. Number of shockabsorbers 2 74. Type Hydraulic telescopic
- 78. Rear suspension (photogr. E), type Rigid axle case and semi elliptical leaf spring
- 79. Type of spring Leaf
- 80. Stabiliser (if fitted)
- 81. Number of shockabsorbers 2 82. Type Hydraulic telescopic

BRAKES (photographs F and G)

- 90. System Hydraulic
- 91. Servo-assistance (if fitted), type
- 92. Number of hydraulic master cylinders 1

	FRONT		REAR	
93. Number of cylinders per wheel	2		1	
94. Bore of wheel cylinder (s)	54.0 mm	in.	19.1 mm	in.
Drum brakes				
95. Inside diameter	mm	in.	229 mm	in.
96. Length of brake linings	mm	in.	219 mm	in.
97. Width of brake linings	mm	in.	40 mm	in.
98. Number of shoes per brake	2			
99. Total area per brake	mm ²	sq. in.	17,550 mm ²	sq. in.
Disc brakes				
100. Outside diameter	284 mm	in.	mm	in.
101. Thickness of disc	10.5 mm	in.	mm	in.
102. Length of brake linings	54 mm	in.	mm	in.
103. Width of brake linings	47.5 mm	in.	mm	in.
104. Number of pads per brake	2			
105. Total area per brake	5,130 mm ²	sq. in.	mm ²	sq. in.



Make NISSAN Model SR(L)311 F.I.A. Rec. No.

ENGINE (photographs J and K)

130. Cycle	4	131. Number of cylinders	4		
132. Cylinder arrangement	In line				
133. Bore	87.2 mm	3.43 in.	134. Stroke	83.0 mm	3.27 in.
135. Capacity per cylinder		495.5 cm ³		30.2 cu.in.	
136. Total cylinder-capacity		1,982 cm ³		121 cu.in.	
137. Material (s) of cylinder block	Cast iron				
138. Material (s) of sleeves (if fitted)					
139. Cylinder-head, material (s)	Al-cast	Number fitted	1		
140. Number of inlet ports	4	141. Number of exhaust ports	4		
142. Compression ratio					
143. Volume of one combustion chamber		cm ³	cu.in.		
144. Piston, material		145. Number of rings			
146. Distance from gudgeon pin centre line to highest point of piston crown	mm	inches			
147. Crankshaft : cast / stamped		148. Type of crankshaft : integral / XXXXXXXX			
149. Number of crankshaft main bearings	5				
150. Material of bearing cap	Cast iron				
151. System of lubrication : X / oil in sump					
152. Capacity, lubricant	7 ltrs	pts	quarts US		
153. Oil cooler : yes / no		154. Method of engine cooling	Water		
155. Capacity of cooling system	8 ltrs	pints	quarts US		
156. Cooling fan (if fitted), dia.	cm	inches			
157. Number of blades of cooling fan					

Bearings

158. Crankshaft main, type	Plain	Dia.	63 mm	in.
159. Connecting rod big end,	Plain	Dia.	52 mm	in.

Weights

160. Flywheel (clean)	kg	lbs	
161. Flywheel with clutch (all turning parts)		kg	lbs
162. Crankshaft	kg	163. Connecting rod	kg lbs
164. Piston with rings and pin	kg	lbs	

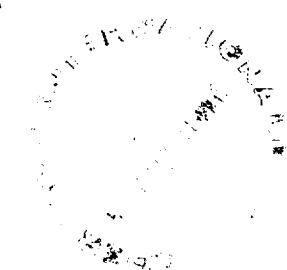

Make

NISSAN

Model

SR(L)311

F.I.A. Rec. No.

FOUR STROKE ENGINES

170. Number of cranks 1 171. location Cylinder head
 172. Type of crank drive Chain
 173. Type of valve operation Rocker arm

INLET (see page 4) *

180. Material(s) of inlet manifold Al-cast
 181. Diameter of valves 46 mm 1.83 inches
 182. Max. valve lift mm in. 183. Number of valve springs 2
 184. Type of spring 185. Number of valves per cylinder 1
 186. Tappet clearance for checking timing (cold) mm inches
 187. Valves open at (with tolerance for tappet clearance indicated)
 188. Valves close at (with tolerance for tappet clearance indicated)
 189. Air filter, type

EXHAUST (see page 4)

195. Material(s) of exhaust manifold Steel
 196. Diameter of valves 36 mm 1.44 inches
 197. Max. valve lift mm in. 198. Number of valve springs 2
 199. Type of spring 200. Number of valves per cylinder 1
 201. Tappet clearance for checking timing (cold) mm inches
 202. Valves open at (with tolerance for tappet clearance indicated)
 203. Valves close at (with tolerance for tappet clearance indicated)

CARBURETION (photograph N)

210. Number of carburetors fitted 2 211. Type Side draught
 212. Make 213. Model
 214. Number of mixture passages per carburetor 2
 215. Flange hole diameter of exit port(s) of carburetor mm in.
 216. Minimum dimensions of mixture passage(s) with piston at max. height (example: SU) mm inches

INJECTION (if fitted)

220. Make of pump 221. Number of plungers
 222. Model or type of pump 223. Total number of injectors
 224. Location of injectors
 225. Minimum diameter of inlet pipe mm inches

* : for additional information concerning two-stroke engines and super-charged engines see page 13.

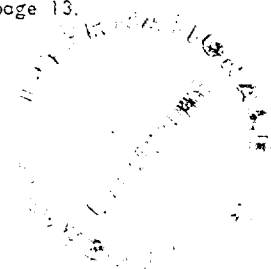

Make NISSAN

Model

SR(L)311

F. I. A. Rec. No.

ENGINE ACCESSORIES

- 230. Fuel pump : mechanical and / or electric
- 231. No. fitted 1
- 232. Type of ignition system Make and break ignition
- 233. No. of distributors 1
- 234. No. of ignition coils
- 235. No. of spark plugs per cylinder 1
- 236. Generator, type: dynamo/alternator-number fitted 1
- 237. Method of drive V-belt
- 238. Voltage of generator 12 volts
- 239. Battery, number 1
- 240. location Engine room
- 241. Voltage of battery 12 volts

ENGINE AND CAR PERFORMANCES (as declared by manufacturer in catalogue)

- 250. Max. engine output (type of horsepower:) at rpm
- 251. Maximum rpm output at that figure
- 252. Maximum torque at rpm
- 253. Maximum speed of the car km/hour miles / hour

255.

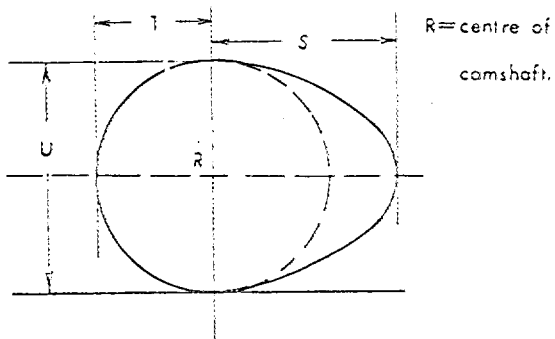

Inlet cam

- S = mm inches
- T = mm inches
- U = mm inches

Exhaust cam

- S = mm inches
- T = mm inches
- U = mm inches



Make NISSAN

Model SR(L) 311

F.I.A. Rec. No

Drawing inlet manifold ports, side of cylinder-head. Indicate scale or dimensions and manufacturing tolerance.

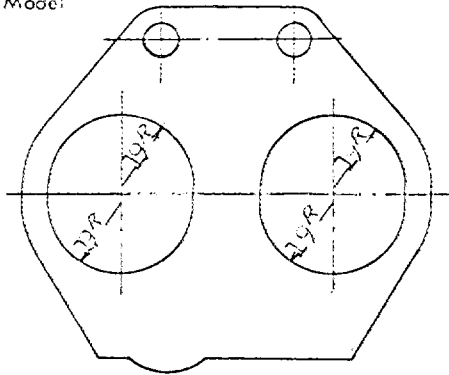

Dimension; mm
Tolerance; ± 1.5

Drawing of entrance to inlet port of cylinder-head. Indicate scale or dimensions and manufacturing tolerance.

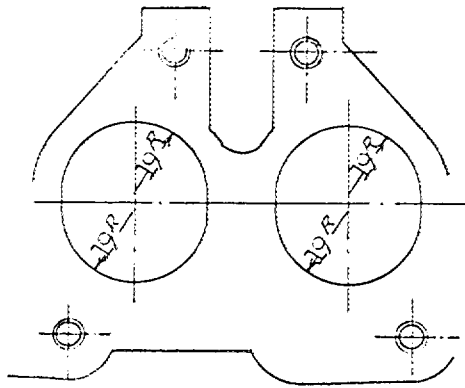

Drawing exhaust manifold ports, side of cylinder-head. Indicate scale or dimensions and manufacturing tolerance.

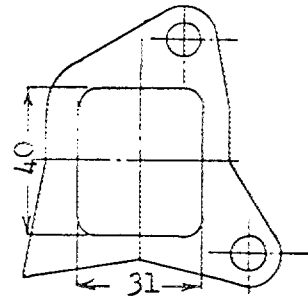
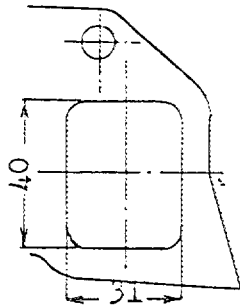

Drawing of exit to exhaust port of cylinder-head. Indicate scale or dimensions and manufacturing tolerance.

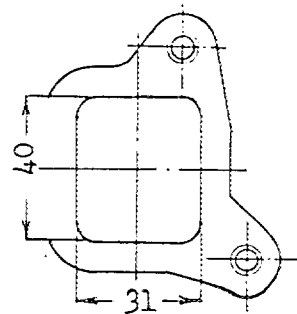
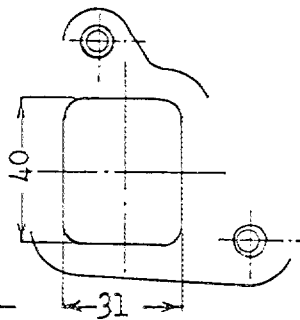

Make

NISSAN

Model

SR(L)311

F. I. A. Rec. No.

DRIVE TRAIN

CLUTCH

- 260. Type of clutch **Dry single plate** 261. No. of plates **1**
- 262. Dia. of clutch plates **20.2** cm inches
- 263. Dia. of linings, inside **13** cm in. outside **20** cm in.
- 264. Method of operating clutch **Hydraulic**

GEAR BOX photograph H)

- 270. Manual type, make **NISSAN** Method of operation **Mechanical**
- 271. No. of gear-box ratios forward **5** 272. Synchronized forward ratios **1, 2, 3, 4, 5**
- 273. Location of gear-shift **Floor**
- 274. Automatic, make type
- 275. No. of forward ratios 276. Location of gear-shift

277.	Manual			Automatic			Alternative manual/ automatic		
	Ratio	No.	teeth	Ratio	No.	teeth	Ratio	No.	teeth
1	2.957	$\frac{29}{23}$	$\times \frac{34}{14}$	2.678	$\frac{28}{23}$	$\times \frac{33}{15}$	1.858	$\frac{28}{23}$	$\times \frac{29}{19}$
2	1.858	$\frac{28}{23}$	$\times \frac{29}{19}$	1.704	$\frac{28}{23}$	$\times \frac{28}{20}$	1.383	$\frac{28}{23}$	$\times \frac{25}{22}$
3	1.311	$\frac{28}{23}$	$\times \frac{23}{26}$	1.262	$\frac{28}{23}$	$\times \frac{28}{27}$	1.217	$\frac{28}{23}$	$\times \frac{27}{27}$
4	1.000			1.000			1.000		
5	0.852	$\frac{28}{23}$	$\times \frac{21}{30}$	0.852	$\frac{28}{23}$	$\times \frac{21}{30}$	0.852	$\frac{28}{23}$	$\times \frac{21}{30}$
6									
reverse	2.922	$\frac{28}{23}$	$\times \frac{17}{14}$	2.922	$\frac{28}{23}$	$\times \frac{17}{15}$	2.922	$\frac{28}{23}$	$\times \frac{17}{17}$

- 278. Overdrive, type
- 279. Forward gears on which overdrive can be selected
- 280. Overdrive ratio

FINAL DRIVE

- 290. Type of final drive **Hypoid gear**
- 291. Type of differential **Bevel gear**
- 292. Type of limit on the differential (if fitted)
- 293. Final drive ratio **3.700 3.889 4.111 4.375 4.625 4.875 5.225**
- Number of teeth **37/10 39/9 37/9 35/8 37/8 39/8 34/8**



Make NISSAN

Model

SR(L)311

F.I.A. Rec. No.

IMPORTANT- The conformity of the car with the following items of the present recognition form is to be disregarded during the scrutineering, when the vehicle has been entered in group 2 (Touring cars) or 3 (Grand Touring cars) : 41, 72, 80, 91, 142, 143, 144, 145, 146, 153, 156, 157, 160, 161, 162, 163, 164, 182, 184, 186, 187, 188, 189, 199, 201, 202, 203, 212, 213, 215, 216, 222, 225, 230, 250, 251, 252, 253, and photographs I, M and N.

During the scrutineering of cars entered in group 4 (Sportscars) only the following items of the present recognition form are to be taken into consideration : 1, 2, 3, 9, 20, 21, 22, 23, 24, 25, 26, 70, 71, 78, 79, 90, 130, 131, 132, 133, 134, 135, 136, 137, 138, 139, 140, 141, 147, 148, 149, 150, 158, 159, 170, 171, 172, 173, 185, 200, 270, 271, 274, 275, 290, 291, 292 and photographs A, B, D, E, F, G, H, J, K, and O.

Optional equipment affecting preceding information. This to be stated together with reference number.

7) Capacity of fuel tank	60 ltrs	15.9 gallon US
50) Type	Pressed steel	Mg-cast
51) Weight	8.4 kg	5.7 kg
52) Method of attachment	Wheel nut (4 nuts)	Wheel nut (4 nuts)
53) Rim diameter	355 mm 14 inch	355 mm 14 inch
54) Rim width	140 mm 5.5 inch	140 mm 5.5 inch

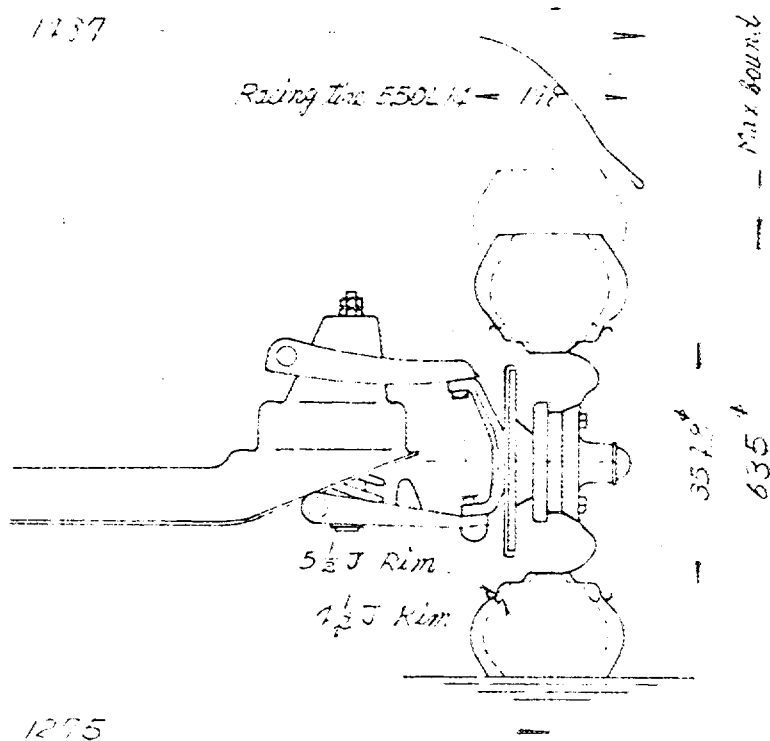

292) Type of limited slip differential

Friction



Make NISSAN

Model SR(L)311

F.I.A. Ref. No.

Photograph

B, 3/4 view of car from rear

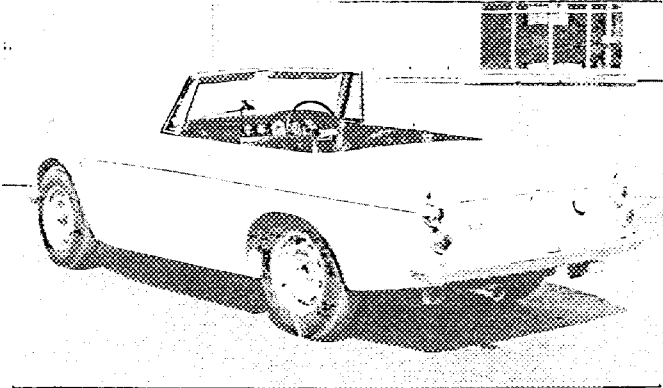

C, interior view of car through driver's door (open or removed) with dashboard

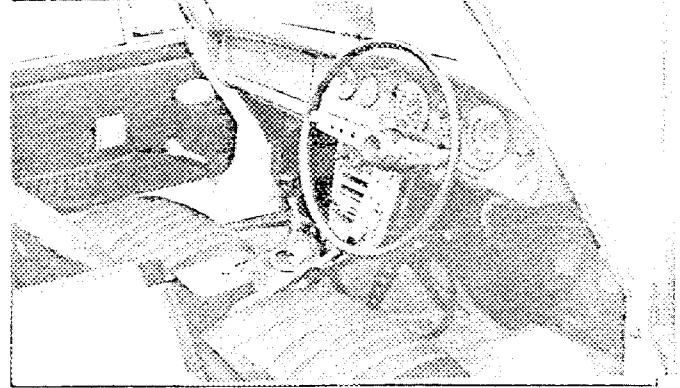

D, front axle complete, removed from car. Without wheels.

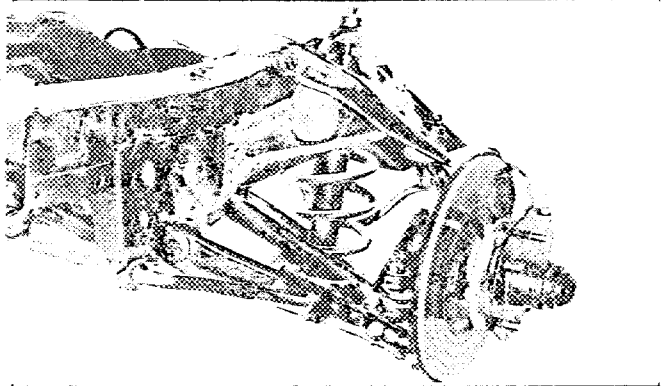

E, Rear axle complete without wheels, removed from car.

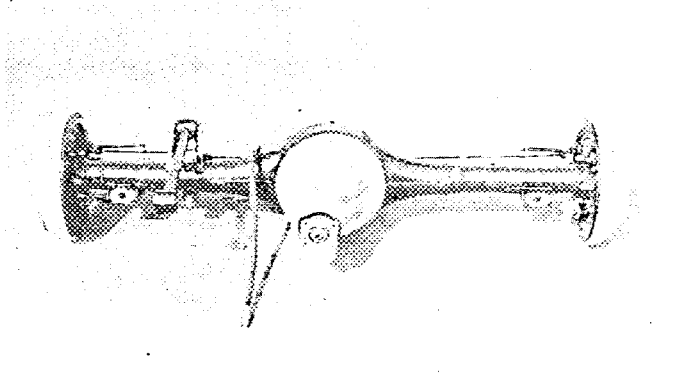

F, front brake, drum removed or disc with caliper(s)

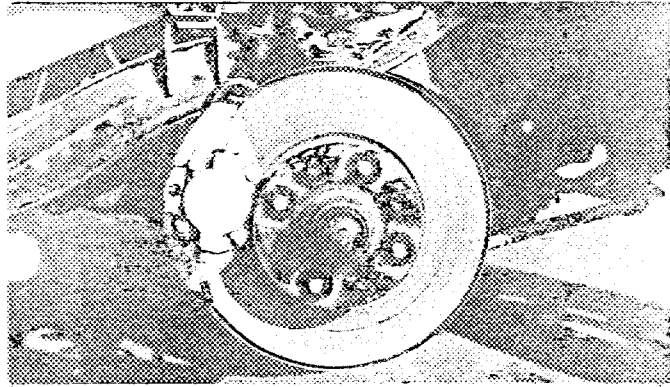

G, rear brake, drum removed or disc with caliper(s)

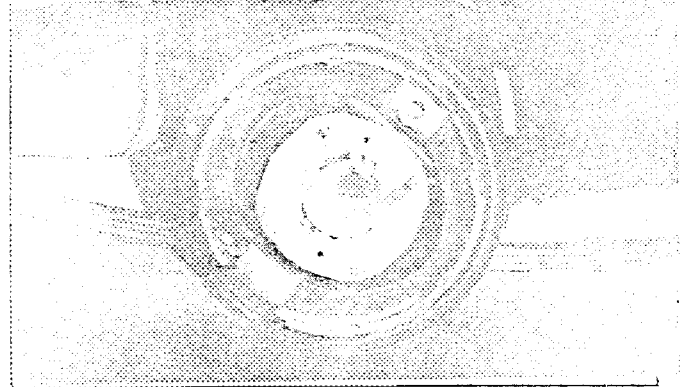

H, gear-box, view from side

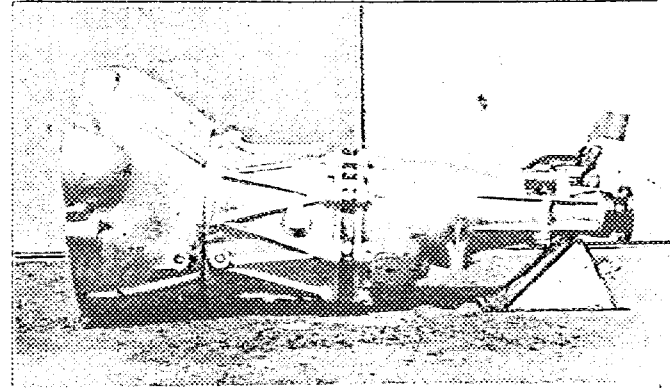

I, silencer + exhaust pipes after exhaust manifold.

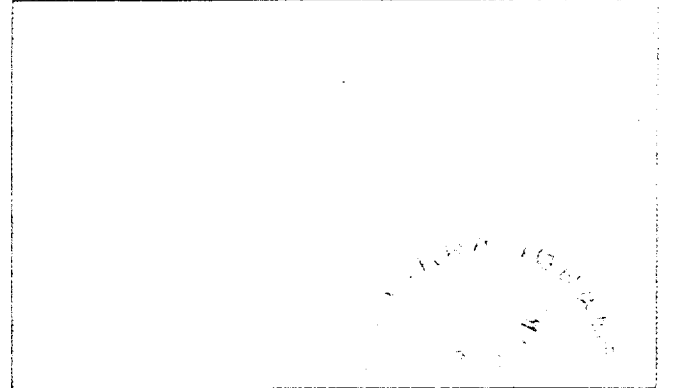

Make

NISSAN

Photograph

Model

SR(L)311

F. I. A. Rec. No.

engine unit out of car, from right. With clutch and accessories but without air filter nor gear-box.

Engine unit out of car, from left. With clutch and accessories but without gear-box nor air filter.

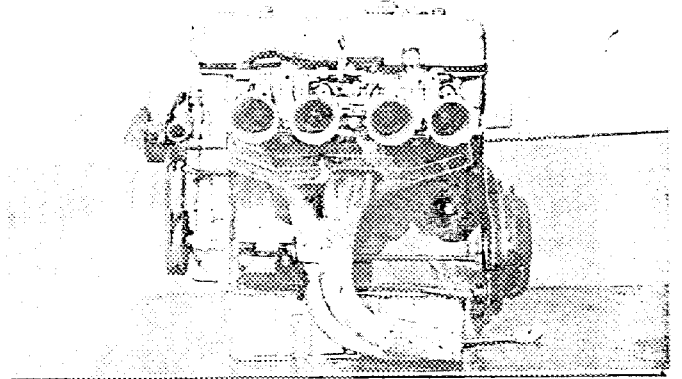
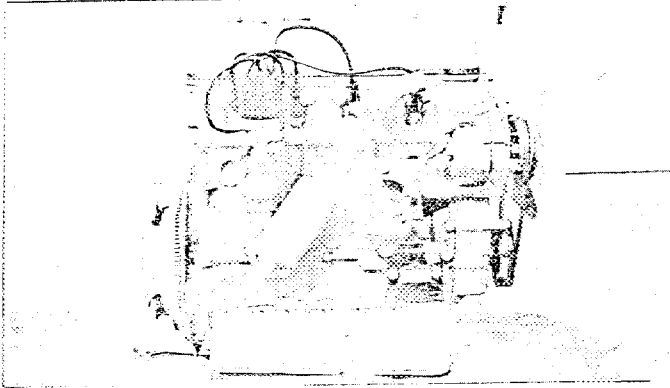

L, combustion chamber

M, piston crown

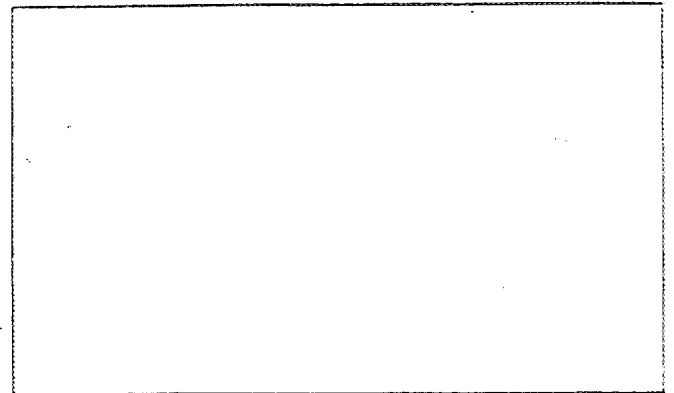
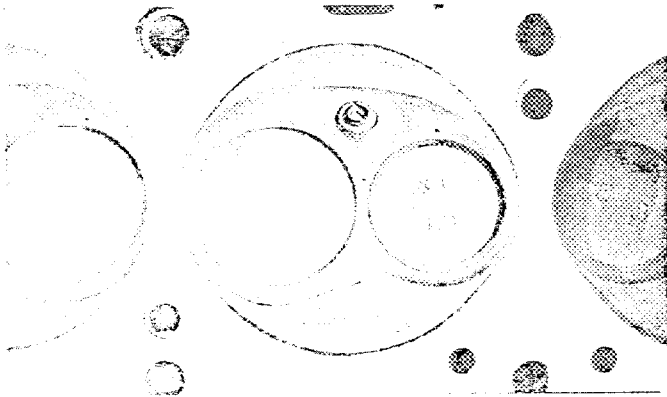

N, Carburettor (view from side of manifold)

O, engine in car with all accessories, bonnet open or removed.

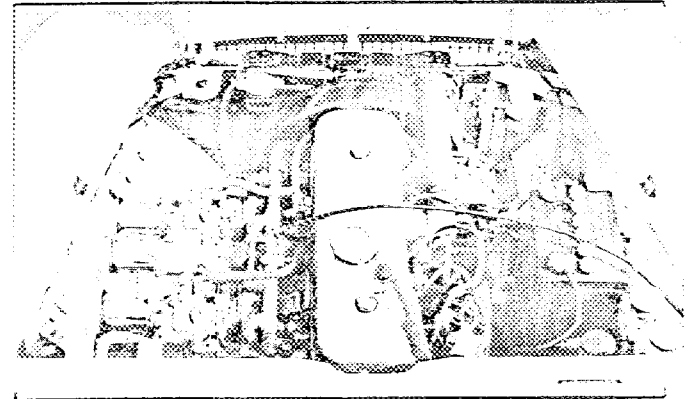
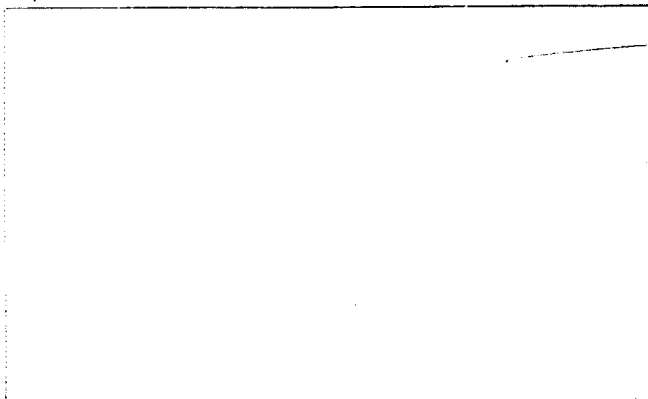

P, inlet manifold

Q, exhaust manifold

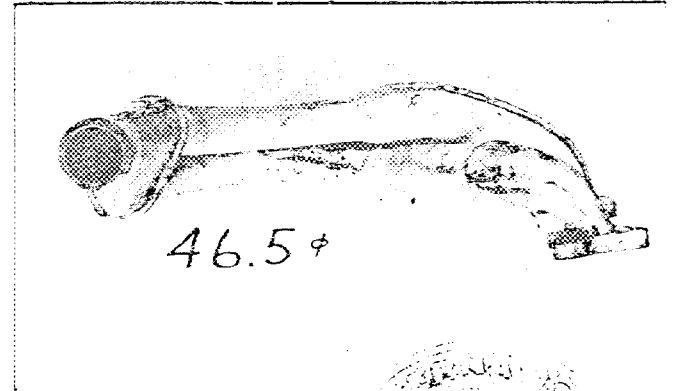
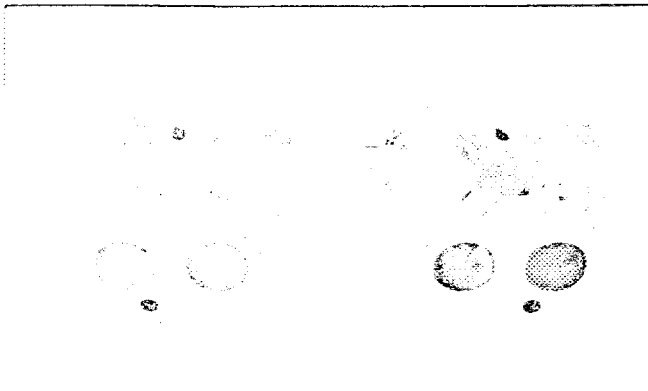

Make NISSAN

Model SR(L)922

F. I. A. Rec. No.

TWO STROKE ENGINES

- 303. System of cylinder scavenging
- 304. Type of lubrication
- 305. Inlet ports, length measured around cylinder wall mm inches
- 306. Height inlet port mm in. 304. Area mm² sq. in.
- 307. Exhaust ports, length measured around cylinder wall mm inches
- 308. Height exhaust port mm in. 307. Area mm² sq. in.
- 309. Transfer port, length measured around cylinder wall mm inches
- 310. Height transfer port mm in. 310. Area mm² sq. in.
- 311. Piston ports, length measured around piston mm inches
- 312. Height piston port mm in. 313. Area mm² sq. in.
- 314. Method of precompression 315. Precompression cyl.: yes/no
- 316. Bore mm inches 317. Stroke mm inches
- 318. Distance from top of cyl. block to highest point of exhaust port : mm inches
- 319. Distance from top of cyl. block to lowest point of inlet port : mm inches
- 320. Distance from top of cyl. block to highest point of transfer port : mm inches
- 321. Drawing of cylinder ports.

330. Supercharging—state full details hereafter :

JAPAN AUTOMOBILE FEDERATION

難波靖江

Yasuharu Nanba



DIMENSIONS OF INTERIOR
 (Conform to Art. 253 b of Appendix J)

For four seaters :

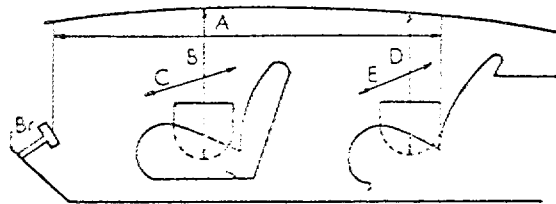

Minimum		Dimensions		
A	B	C	D	E

cm

For two seaters :

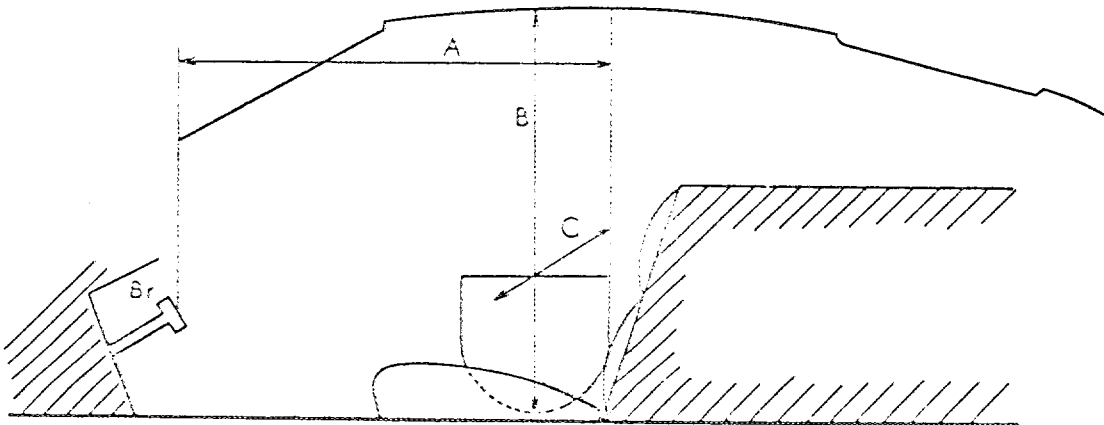

Minimum		Dimensions
A	B	C
108	67	113

cm





JAPAN AUTOMOBILE FEDERATION F.I.A. Homol. No 566

111E

FEDERATION INTERNATIONALE DE L'AUTOMOBILE

Amendment to Form of Recognition in accordance with the International Sporting Code.

Make NISSAN MOTOR CO., LTD. Model SR 311
Modification's application starts with serial No. chassis 2250 engine U20-2469
Application of this amendment started the Dec, 1967
Commercial denomination after application of modifications Jan, 1968
The modifications are to be considered as: ~~Yvesca~~ / normal evolution of the type
Date amendment is valid from 1st May '68 list 1968/6

Description of amendment

The following item have been supplemented,

Photograph C Interior view of through driver's door (open or removed) with dashboard

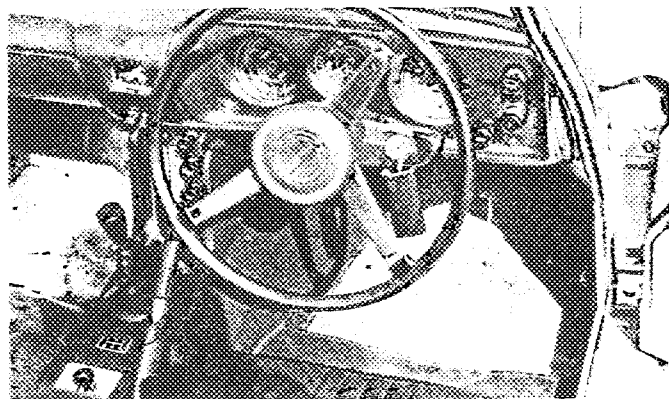

法人団 日本自動車連盟
機械振興会館内
港区芝公園第三号地一番五

Stamp and signature of National Sporting Authority

JAPAN AUTOMOBILE FEDERATION

Handwritten signature of Yasuharu Nanba

Yasuharu Nanba

Stamp and signature of F.I.A.

Handwritten signature and circular stamp of the F.I.A.

Make NISSAN

Model SR311

Photograph C

Interior view

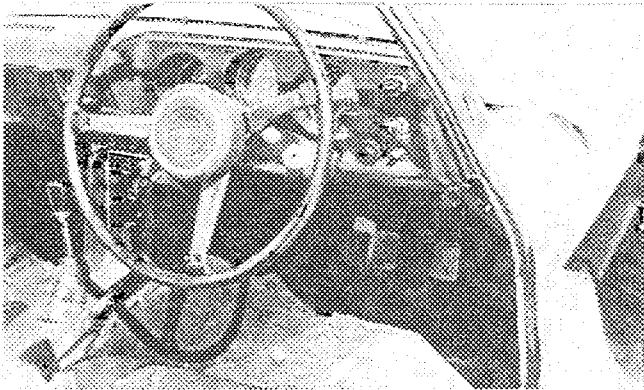

Photograph H

Gear box, view from side

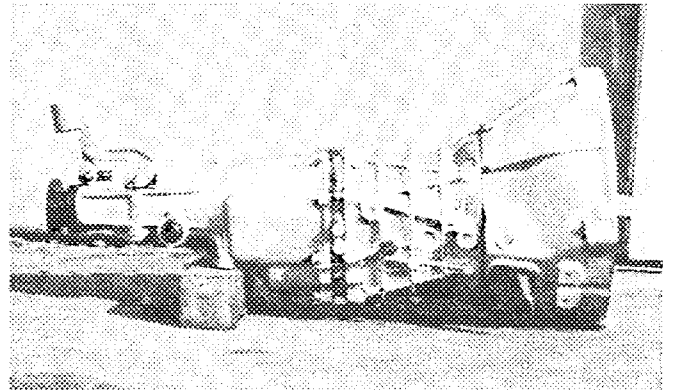



JAPAN AUTOMOBILE FEDERATION F.I.A. Homol. No 566 /2/1V

FEDERATION INTERNATIONALE DE L'AUTOMOBILE

Amendment to Form of Recognition in accordance with the International Sporting Code.

Make NISSAN MOTOR CO., LTD. Model SR 311
Modification's application starts with serial No. chassis 00001 engine U20-00101
Application of this amendment started the Dec, 1966
Commercial denomination after application of modifications Mar, 1967
The modifications are to be considered as: Variant / new solutions of the base
Date amendment is valid from 1st May '68 List 1968/6

Description of amendment

The following item has been added.

Optional equipment

Over fender

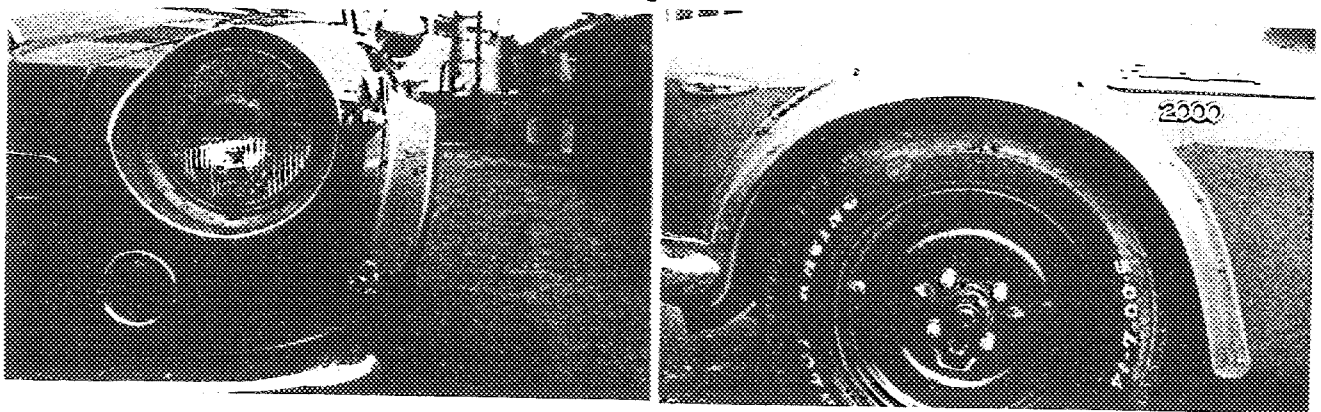

Stamp and signature of National Sporting Authority

JAPAN AUTOMOBILE FEDERATION

Handwritten signature of Yasuharu Nanba

Yasuharu Nanba



東京港区芝公園第三号地一番
機械振興会館内
日本自動車連盟

Stamp and signature of F.I.A.

Handwritten signature of F.I.A. official





JAPAN AUTOMOBILE FEDERATION F.I.A. Homol. No 566/3/2 U

FEDERATION INTERNATIONALE DE L'AUTOMOBILE

Amendment to Form of Recognition in accordance with the International Sporting Code.

Make NISSAN MOTOR CO., LTD. Model SR311
Modification's application starts with serial No. chassis SR311-00001 engine U20-00101
Application of this amendment started the Sept. 1968
Commercial denomination after application of modifications Oct. 1968
The modifications are to be considered as: Variant / modification of design
Date amendment is valid from 11/1/68 List 1968/10

Description of amendment FIA Homol No. 566
293) Final drive ratio 5.857
Number of teeth 41/7

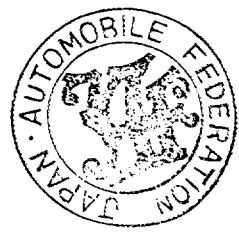

東京都港区芝公園第三号地一番五
機械振興会館内
法人 日本自動車連盟

Stamp and signature of National Sporting Authority

JAPAN AUTOMOBILE FEDERATION

Handwritten signature of Yasuharu Nanba

Yasuharu Nanba

Stamp and signature of F.I.A.

Handwritten signature of F.I.A.



FEDERATION INTERNATIONALE DE L'AUTOMOBILE

Amendment to Form of Recognition
in accordance with the International
Sporting Code.

Make NISSAN Model SR311
Modification's application starts with serial No. chassis SR311-03001
Application of this amendment started the engine U20-6091

Commercial denomination after application of modifications
The modifications are to be considered as: ~~XXXXXX~~ / normal evolution of the type
Date amendment is valid from 1st Jan. by List 1969/1

Description of amendment

The following items have been supplemented

Photograph A

3/4 view of car from front

Photograph B

3/4 view of car from rear

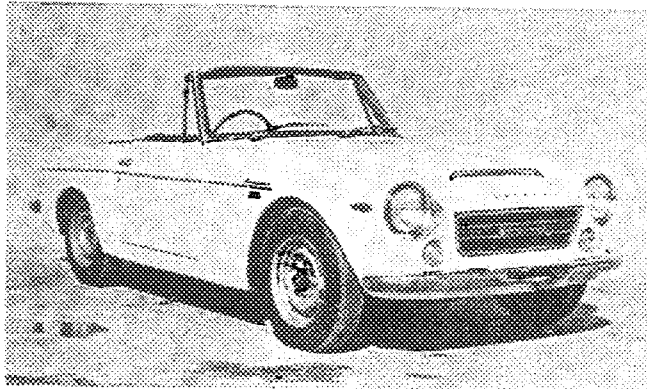

Stamp and signature of
National Sporting Authority

JAPAN AUTOMOBILE FEDERATION

Yasuharu Nanba

Yasuharu Nanba

東京港区芝公園第三号地一番五
日本自動車連盟
法人団
櫻木振興会館内

Stamp and signature of F.I.A.

[Signature]

