



# JAPAN AUTOMOBILE FEDERATION

F. I. A. Recognition No.

Group

1

5367

## FEDERATION INTERNATIONALE DE L'AUTOMOBILE

Form of recognition in accordance with  
Appendix J to the International Sporting Code.

Manufacturer Toyota Motor Co., Ltd.

Serial No of chassis RT71-000001

engine 6R 000001

Recognition is valid from 1 Octobre 70

Cylinder-capacity 1707 cm<sup>3</sup> 104.1 cu. in.

Model Corona MarkII Hardtop, RT71-K

Manufacturer Toyota Motor Co., Ltd.

Manufacturer Toyota Motor Co., Ltd.

List 70/10

The manufacturing of the model described in this recognition form was started on Feb. 1970 and the minimum production of 5000 identical cars, in accordance with the specifications of this form was reached on May 1970

Photograph A, 3/4 view of car from front



東京港区芝公園三丁目一番五  
機械振興会館内  
法人 日本自動車連盟

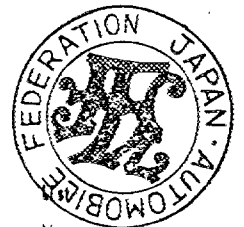

The vehicle described in this form has been subject to the following amendments :

### Variants

on	19	rec. No.	List
on	19	rec. No.	List
on	19	rec. No.	List
on	19	rec. No.	List
on	19	rec. No.	List

### Normal evolution of the type

on	19	rec. No.	List
on	19	rec. No.	List
on	19	rec. No.	List
on	19	rec. No.	List
on	19	rec. No.	List

Stamp and signature of the  
National Sporting Authority

Stamp and signature of the F. I. A.

Make **Toyota**

Model **RT71 - K**

F. I. A. Rec. No.

IMPORTANT - the underlined items must be stated in two measuring systems, one of which must be the metric system. See conversion table hereafter.

**CAPACITIES AND DIMENSIONS**

1. <u>Wheelbase</u>	2510	mm	98.8	inches
2. <u>Front track</u>	1325	mm	52.2	inches *
3. <u>Rear track</u>	1320	mm	52.0	inches *
4. Overall length of the car	429.5	cm		inches
5. Overall width of the car	160.5	cm		inches
6. Overall height of the car	139.5	cm		inches
7. <u>Capacity of fuel tank</u> (reserve included)			52	ltrs
	13.7	Gallon US		Gallon imp.
8. Seating capacity				
9. <u>Weight</u> , total weight of the car with normal equipment, water, oil and spare wheel but without fuel nor repair tools:				
	935	kg	2055	lbs
				cwt

\* Differences in track caused by the use of other wheels with different rim widths must be stated when recognition is requested for the wheels concerned.

Specify ground clearance in relation to the track and give drawing of two fixed points of the vehicle's structure at which measurements are taken.

These ground clearance dimensions are only for information when checking the track and can in no way affect the eligibility of the car.

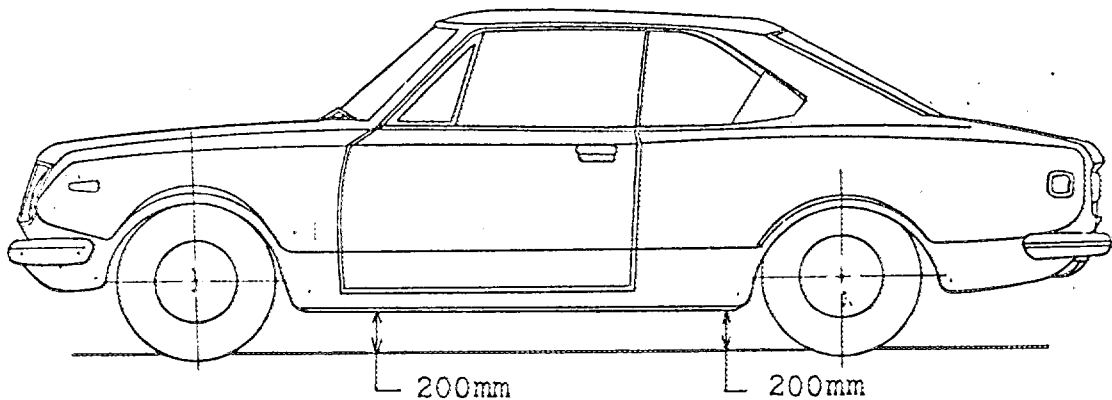

**CONVERSION TABLE**

1 inch / pouce	-- 2.54 cm	1 quart US	-- 0.9464 ltrs
1 foot / pied	-- 30.4794 cm	1 pint (pt)	-- 0.568 ltrs
1 square inch / pouce carre	-- 6.452 cm <sup>2</sup>	1 gallon imp.	-- 4.546 ltrs
1 cubic inch / pouce cube	-- 16.387 cm <sup>3</sup>	1 gallon US	-- 3.785 ltrs
1 pound / livre (lb)	-- 453.593 gr.	1 hundred weight (cwt)	-- 50.802 kg

Make Toyota

Model. RT71 - .K

F.I.A. Rec. No.

**CHASSIS AND COACHWORK** (Photographs A, B and C)

- 20. Chassis/body construction : ~~separate~~ / unitary construction
- 21. Unitary construction, material (s) Steel  
Separate construction
- 22. Separate Constructions: Material(s) of chassis
- 23. Material (s) of coachwork
- 24. Number of doors 2 Material (s) Steel
- 25. Material (s) of bonnet Steel
- 26. Material (s) of boot lid Steel
- 27. Material (s) of rear-window Glass
- 28. Material (s) of windscreen Glass
- 29. Material (s) of front-door windows Glass
- 30. Material (s) of rear-door windows
- 31. Sliding system of door windows Vertical, Manual
- 32. Material (s) of rear-quarter light Glass

**ACCESSORIES AND UPHOLSTERY**

- 38. Interior heating : ~~yes~~ - no
- 39. Air-conditioning : ~~yes~~ - no
- 40. Ventilation : yes - ~~yes~~
- 41. Front seats, type of seats and upholstery Separate, Vinyl leather
- 42. Weight of front seat (s), complete with supports and rails, out of the car :  
17Kg x 2 kg lbs
- 43. Rear seats, type of seats and upholstery Bench, Vinyl leather
- 44. Front bumper, material (s) Steel Weight 5.9 kg lbs
- 45. Rear bumper, material (s) Steel Weight 5.7 kg lbs

**WHEELS**

- 50. Type Pressed steel
- 51. Weight (per wheel, without tyre) 6 kg lbs
- 52. Method of attachment 4 Nuts
- 53. Rim diameter 330.2 mm 13 inches
- 54. Rim width 114.3 mm 4.5 inches

**STEERING**

- 60. Type Recirculating ball
- 61. Servo-assistance : ~~yes~~ - no
- 62. Number of turns of steering wheel from lock to lock 3  
3  
4
- 63. In case of servo-assistance

Make Toyota

Model

RT71 - K

F. I. A. Rec. No.

SUSPENSION

70. Front suspension (photogr. D), type		Independent, Wishbone.
71. Type of spring		Coil
72. Stabiliser (if fitted)		Torsion bar
73. Number of shockabsorbers	2	74. Type Hydraulic telescopic
78. Rear suspension (photogr. E), type		Rigid
79. Type of spring		Leaf
80. Stabiliser (if fitted)		
81. Number of shockabsorbers	2	82. Type Hydraulic telescopic

BRAKES (photographs F and G)

90. System	Hydraulic
1. Servo-assistance (if fitted), type	Vacuum servo
92. Number of hydraulic master cylinders	2

	FRONT		REAR		
	2		1		
93. Number of cylinders per wheel					
94. Bore of wheel cylinder (s)	48.1	mm	in. 20.64	mm	in.
<b>Drum brakes</b>					
95. Inside diameter		mm	in. 228.6	mm	in.
96. Length of brake linings		mm	in. 243	mm	in.
97. Width of brake linings		mm	in. 40	mm	in.
98. Number of shoes per brake				2	
99. Total area per brake		mm <sup>2</sup>	sq. in. 194x10 <sup>2</sup>	mm <sup>2</sup>	sq. in.
<b>Disc brakes</b>					
100. Outside diameter	244	mm	in.	mm	in.
101. Thickness of disc	10	mm	in.	mm	in.
102. Length of brake linings	47.5	mm	in.	mm	in.
103. Width of brake linings	60.9	mm	in.	mm	in.
104. Number of pads per brake			2		
105. Total area per brake	56x10 <sup>2</sup>	mm <sup>2</sup>	sq. in.	mm <sup>2</sup>	sq. in.

Make Toyota

Model RT71 - K

F. I. A. Rec. No.

ENGINE (photographs J and K)

130. Cycle	4	131. Number of cylinders	4
132. Cylinder arrangement	In line		
133. Bore 86 mm	3.38 in.	134. Stroke 73.5 mm	2.89 in.
135. Capacity per cylinder	426.8	cm <sup>3</sup>	26.0 cu. in.
136. Total cylinder-capacity	1707	cm <sup>3</sup>	104.1 cu. in.
137. Material (s) of cylinder block	Cast iron		
138. Material (s) of sleeves (if fitted)			
139. Cylinder-head, material (s)	Cast iron	Number fitted	1
140. Number of inlet ports	4	141. Number of exhaust ports	4
142. Compression ratio	8.5		
143. Volume of one combustion chamber		56.9 cm <sup>3</sup>	cu. in.
144. Piston, material	Aluminum - Alloy	145. Number of rings	3
146. Distance from gudgeon pin centre line to highest point of piston crown	39.8 mm		
		inches	
147. Crankshaft : <del>XXXX</del> / stamped		148. Type of crankshaft : integral / <del>XXXX</del>	
149. Number of crankshaft main bearings	5		
150. Material of bearing cap	Cast iron		
151. System of lubrication : <del>XXXX</del> / oil in sump			
152. Capacity, lubricant 4.1 ltrs		pts	quarts US
153. Oil cooler : <del>yes</del> / no		154. Method of engine cooling	Water
155. Capacity of cooling system 7.4 ltrs		pints	quarts US
156. Cooling fan (if fitted), dia. 36 cm		inches	
157. Number of blades of cooling fan	4		

Bearings

158. Crankshaft main, type	Plain	Dia.	60	mm	in.
159. Connecting rod big end,	Plain	Dia.	53	mm	in.

Weights

160. Flywheel (clean)	10.6	kg	lbs
161. Flywheel with clutch (all turning parts)			16.6 kg lbs
162. Crankshaft	14.6	kg	lbs
163. Connecting rod			0.76 kg lbs
164. Piston with rings and pin			0.55 kg lbs

Make Toyota

Model RT71 - K

F.I.A. Rec. No.

FOUR STROKE ENGINES

170. Number of camshafts 1 171. location Cylinder head  
 172. Type of camshaft drive Chain  
 173. Type of valve operation Rocker

INLET (see page 8) \*

180. Material(s) of inlet manifold Aluminum - Alloy  
 181. Diameter of valves 43 mm 1.69 inches  
 182. Max. valve lift 10 mm 0.39 in. 183. Number of valve springs 2  
 184. Type of spring Coil 185. Number of valves per cylinder 1  
 186. Tappet clearance for checking timing (cold) 0.18 mm inches  
 187. Valves open at (with tolerance for tappet clearance indicated) B. T. D. C.  $15^{\circ} \pm 7^{\circ}$   
 188. Valves close at (with tolerance for tappet clearance indicated) A. B. D. C.  $45^{\circ} \pm 7^{\circ}$   
 189. Air filter, type Dry

EXHAUST (see page 8)

195. Material (s) of exhaust manifold Cast iron  
 196. Diameter of valves 34 mm 1.34 inches  
 197. Max. valve lift 10 mm 0.39 in. 198. Number of valve springs 2  
 199. Type of spring Coil 200. Number of valves per cylinder 1  
 201. Tappet clearance for checking timing (cold) 0.33 mm inches  
 202. Valves open at (with tolerance for tappet clearance indicated) B. B. D. C.  $50^{\circ} \pm 7^{\circ}$   
 203. Valves close at (with tolerance for tappet clearance indicated) A. T. D. C.  $10^{\circ} \pm 7^{\circ}$

CARBURETION (photograph N)

210. Number of carburetors fitted 1 211. Type Down draught  
 212. Make Aisan 213. Model 6R  
 214. Number of mixture passages per carburetor 2  
 215. Flange hole diameter of exit port(s) of carburetor  $30^{\phi}$  &  $34^{\phi}$  mm in.  
 216. Minimum dimensions of mixture passage(s) ~~with a minimum of max height to angle of 60°~~  
 $23^{\phi}$  &  $28^{\phi}$  mm inches

INJECTION (if fitted)

220. Make of pump 221. Number of plungers  
 222. Model or type of pump 223. Total number of injectors  
 224. Location of injectors  
 225. Minimum diameter of inlet pipe mm inches

\* ) for additional information concerning two-stroke engines and super-charged engines see page 13.

Make Toyota

Model RT71 - K

F. I. A. Rec. No.

**ENGINE ACCESSORIES**

- 230. Fuel pump : mechanical ~~or XXXX~~ ~~or XXXX~~
- 231. No. fitted 1
- 232. Type of ignition system Make & break
- 233. No. of distributors 1
- 234. No. of ignition coils 1
- 235. No. of spark plugs per cylinder 1
- 236. Generator, type: ~~XXXX~~ alternator-number fitted 1
- 237. Method of drive V belt
- 238. Voltage of generator 12 volts
- 239. Battery, number 1
- 240. Location Engine room
- 241. Voltage of battery 12 volts

**ENGINE AND CAR PERFORMANCES (as declared by manufacturer in catalogue)**

- 250. Max. engine output 95ps (type of horsepower: JIS ) at 5500 rpm
- 251. Maximum rpm 6400 output at that figure 89.5ps
- 252. Maximum torque 14.0Kg-m at 3800 rpm
- 253. Maximum speed of the car 155 km/hour miles / hour

255.

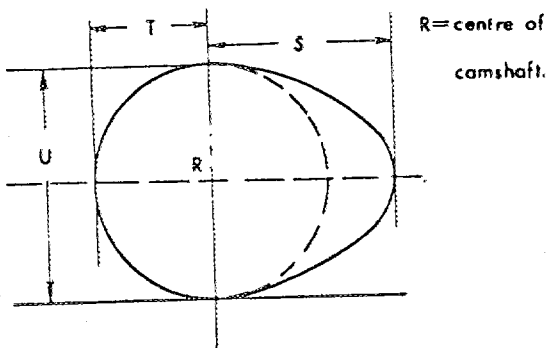

<u>Inlet cam</u>				
S =	26.1	mm	1.023	inches
T =	18.0	mm	0.709	inches
U =	36.0	mm	1.417	inches
<u>Exhaust cam</u>				
S =	26.2	mm	1.032	inches
T =	18.0	mm	0.709	inches
U =	36.1	mm	1.421	inches



Make Toyota

Model RT71 - K

Drawing inlet manifold ports, side of cylinder-head. Indicate scale or dimensions and manufacturing tolerance.

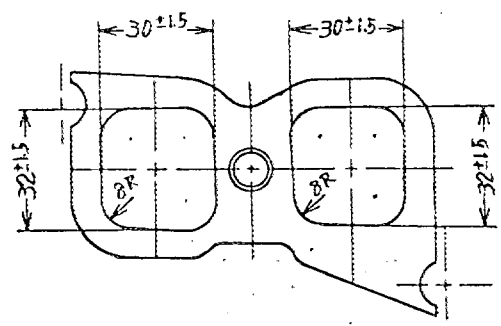

Drawing of entrance to inlet port of cylinder-head. Indicate scale or dimensions and manufacturing tolerance.

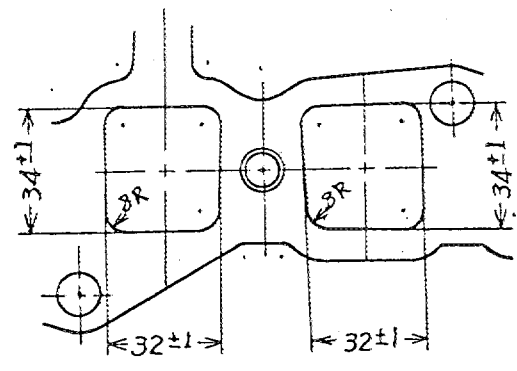

Drawing exhaust manifold ports, side of cylinder-head. Indicate scale or dimensions and manufacturing tolerance.

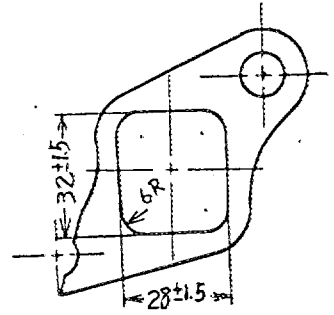
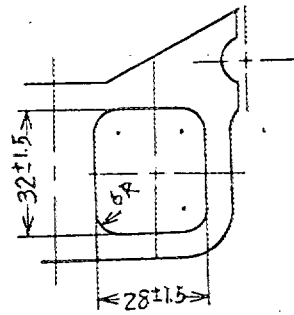

Drawing of exit to exhaust port of cylinderhead. Indicate scale or dimensions and manufacturing tolerance.

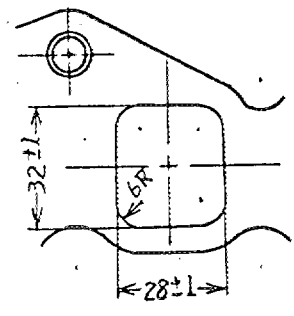
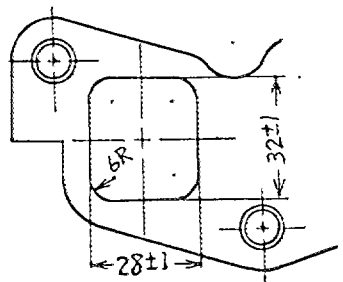

Unit : mm



Make Toyota

Model RT71 - k

F. I. A. Rec. No.

**DRIVE TRAIN**

**CLUTCH**

- 260. Type of clutch Dry single plate
- 261. No. of plates 1
- 262. Dia. of clutch plates 20.5 cm inches
- 263. Dia. of linings, inside 14.0 cm in. outside 20.0 cm in.
- 264. Method of operating clutch Hydraulic

**GEAR BOX (photograph H)**

- 270. Manual type, make Toyota Method of operation Mechanical
- 271. No. of gear-box ratios forward 4 272. Synchronized forward ratios 1, 2, 3 & 4
- 273. Location of gear-shift Floor
- 274. Automatic, make type
- 275. No. of forward ratios 276. Location of gear-shift

277.	Manual			Automatic			Alternative manual/ <del>automatic</del>		
	Ratio	No.	teeth	Ratio	No.	teeth	Ratio	No.	teeth
1	3.673	$\frac{31}{18}$	$\times \frac{32}{15}$				3.337	$\frac{31}{18}$	$\times \frac{31}{16}$
2	2.114	$\frac{31}{18}$	$\times \frac{27}{22}$				1.948	$\frac{31}{18}$	$\times \frac{26}{23}$
3	1.403	$\frac{31}{18}$	$\times \frac{22}{27}$				1.304	$\frac{31}{18}$	$\times \frac{21}{27}$
4	1.000						1.000		
5									
6									
reverse	4.183	$\frac{31}{18}$	$\times \frac{22}{14} \times \frac{34}{22}$				4.183	$\frac{31}{18}$	$\times \frac{22}{14} \times \frac{34}{22}$

- 278. Overdrive, type
- 279. Forward gears on which overdrive can be selected
- 280. Overdrive ratio

**FINAL DRIVE**

- 290. Type of final drive Hypoid gear
- 291. Type of differential Bevel gear
- 292. Type of limited slip differential (if fitted)
- 293. Final drive ratio 4.111 , 4.375
- Number of teeth  $\frac{37}{9}$  ,  $\frac{35}{8}$

Make Toyota

Model RT71 - K

F.I.A. Rec. No.

**IMPORTANT-** The conformity of the car with the following items of the present recognition form is to be disregarded during the scrutineering, when the vehicle has been entered in group 2 (Touring cars) or 3 (Grand Touring cars) : 41, 72, 80, 91, 142, 143, 144, 145, 146, 153, 156, 157, 160, 161, 162, 163, 164, 182, 184, 186, 187, 188, 189, 199, 201, 202, 203, 212, 213, 215, 216, 222, 225, 230, 250, 251, 252, 253, and photographs I, M, N, and page 8

During the scrutineering of cars entered in group 4 (Sportscars) only the following items of the present recognition form are to be taken into consideration : 1, 2, 3, 9, 20, 21, 22, 23, 24, 25, 26, 70, 71, 78, 79, 90, 130, 131, 132, 133, 134, 135, 136, 137, 138, 139, 140, 141, 147, 148, 149, 150, 158, 159, 170, 171, 172, 173, 185, 200, 270, 271, 274, 275, 290, 291, 292 and photographs A, B, D, E, F, G, H, J, K, and O.

Optional equipment affecting preceding information. This to be stated together with reference number.

SR II

NOT VALID FOR GROUP 1 ONLY

Wing extensions

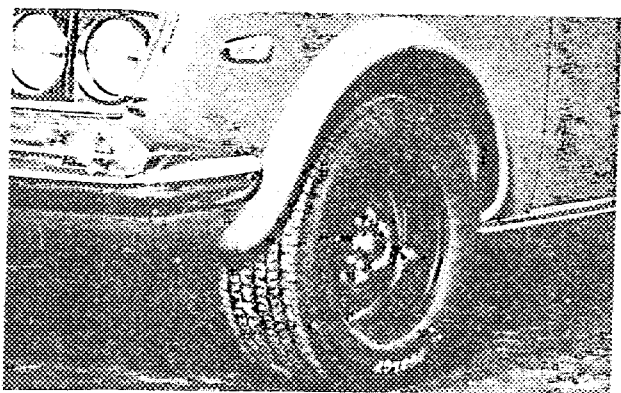

Front

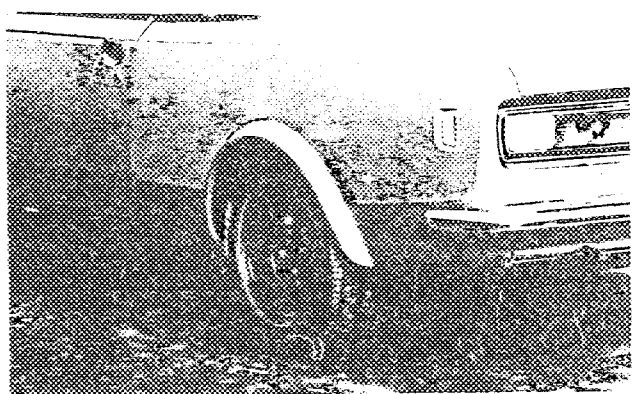
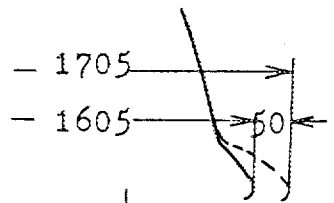

Rear

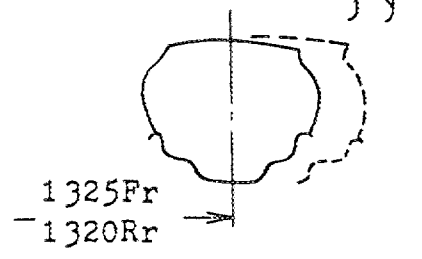

Center of original rim

Unit : mm

東京都港区芝公園三丁目一番五  
機械振興会  
法人団 日本自動車連盟



5367

Make Toyota

Model RT71 - K

F.I.A. Rec. No.

B. 3/4 view of car from rear

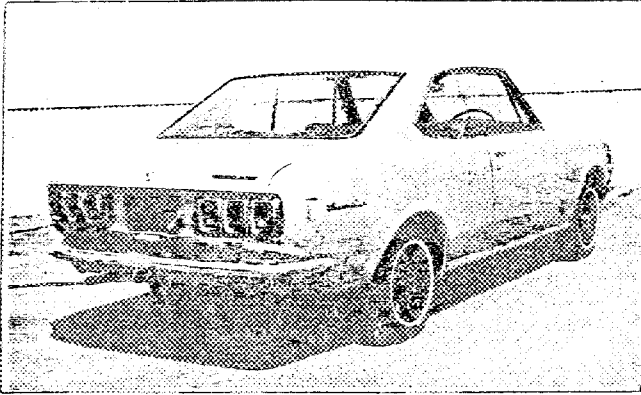

C. interior view of car through driver's door (open or removed) with dashboard

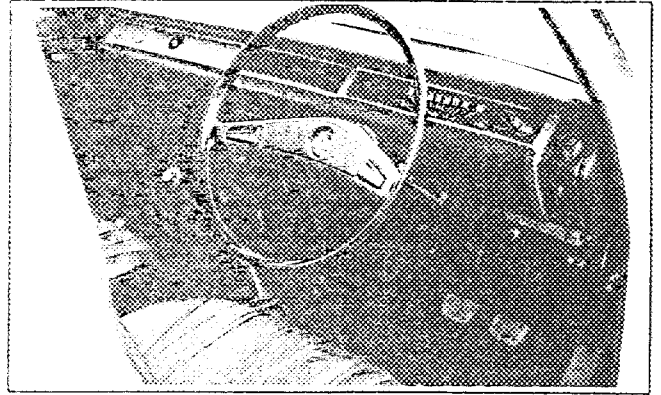

D. front axle complete, removed from car. Without wheels

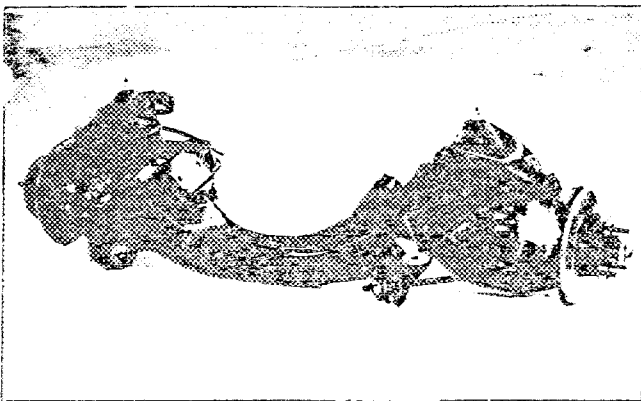

E. Rear axle complete without wheels, removed from car.

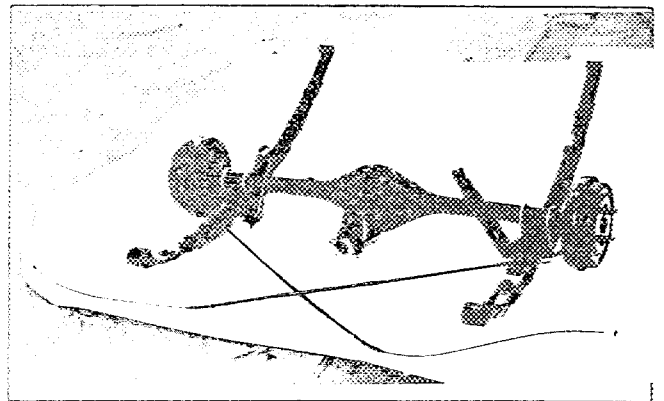

F. front brake, drum removed or disc with calipers

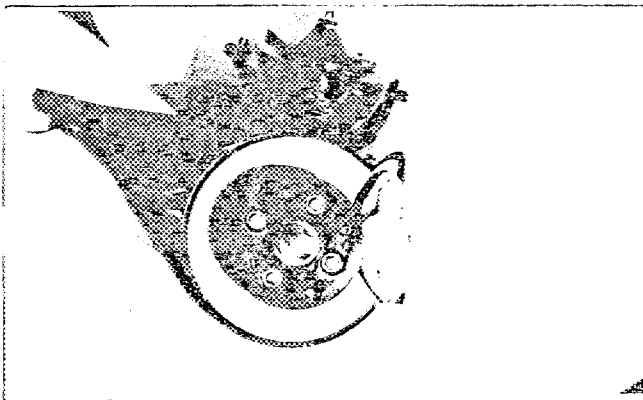

G. rear brake, drum removed or disc with calipers

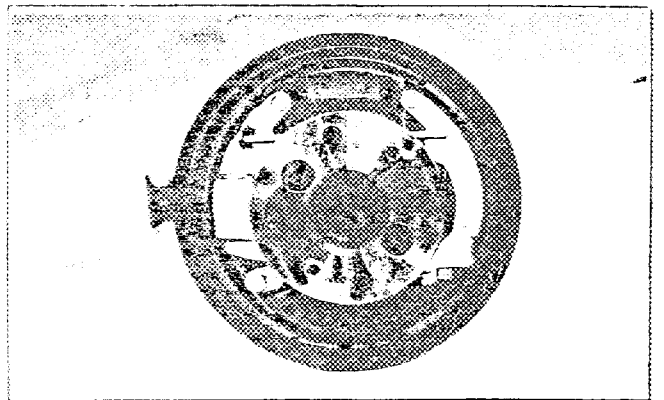

H. gear-box, view from side

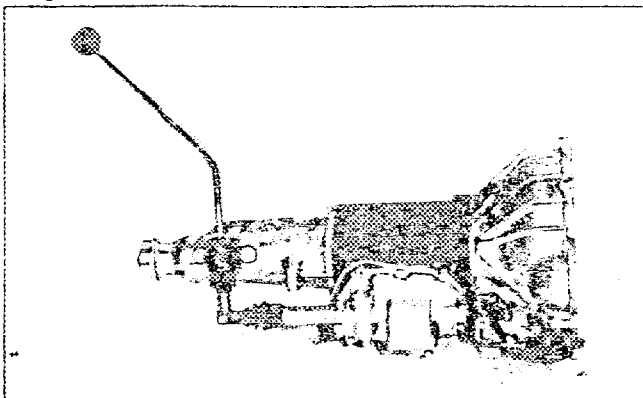

I. silencer + exhaust pipes after exhaust manifold.

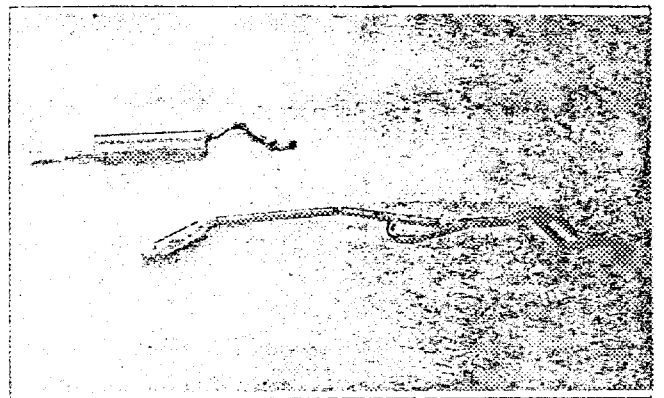

Make Toyota

Model RT71 - K

F. I. A. Rec. No

engine unit out of car, from right. With clutch and accessories but without air filter nor gear-box.

Photograph

Engine unit out of car, from left. With clutch and accessories but without gear-box nor air filter.

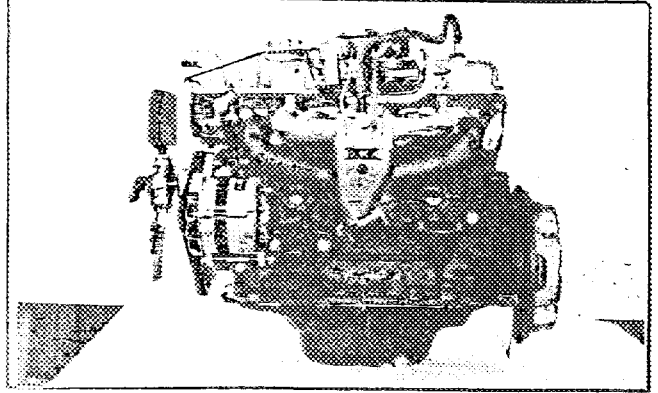
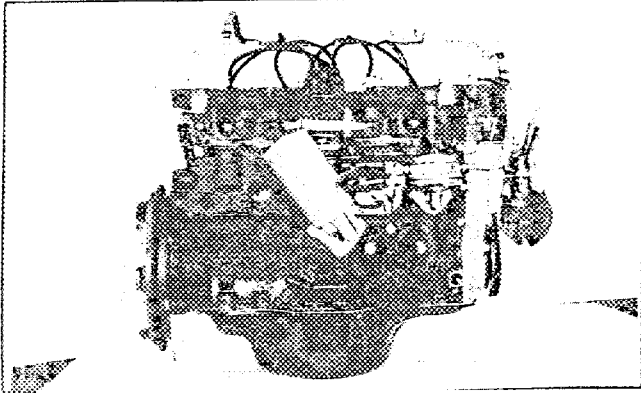

L, combustion chamber

M, piston crown

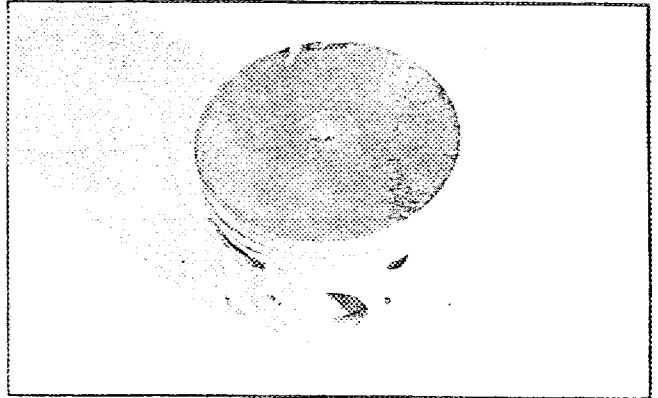
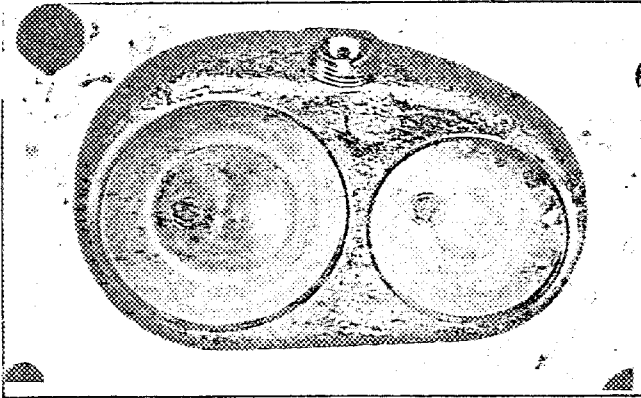

N, Carburettor (view from side of manifold)

O, engine in car with all accessories, bonnet open or removed.

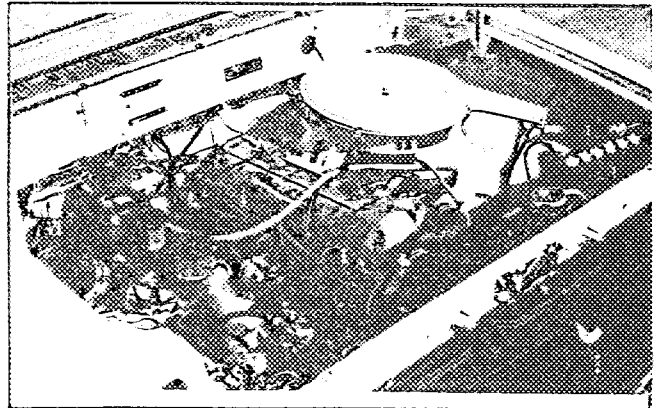
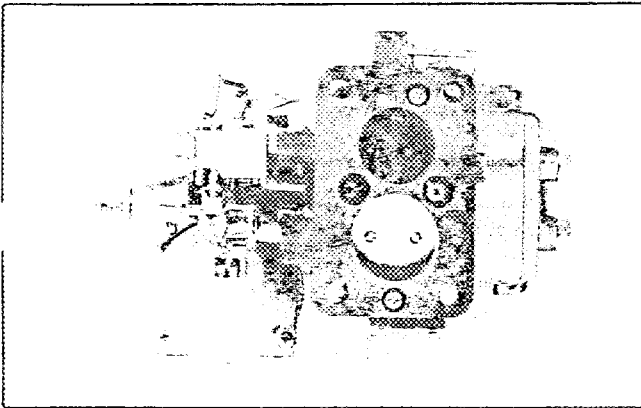

P, inlet manifold

Q, exhaust manifold

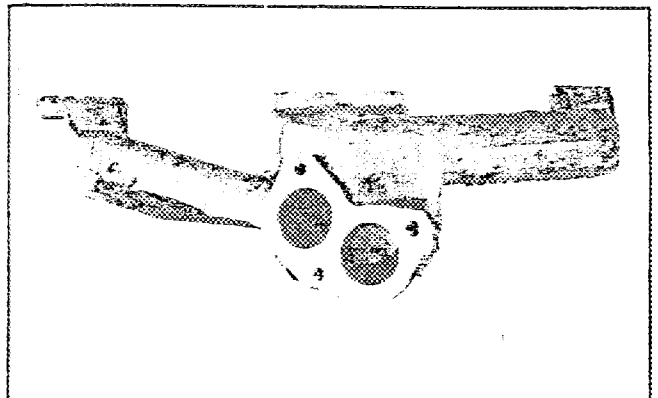
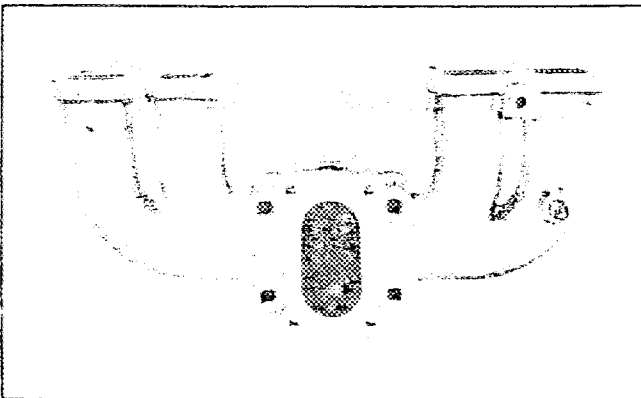

Make Toyota

Model RT71 - K

F.I.A. Rec. No.

**DIMENSIONS OF INTERIOR**  
 (Conform to Art. 253 b of Appendix J)

For four seaters :

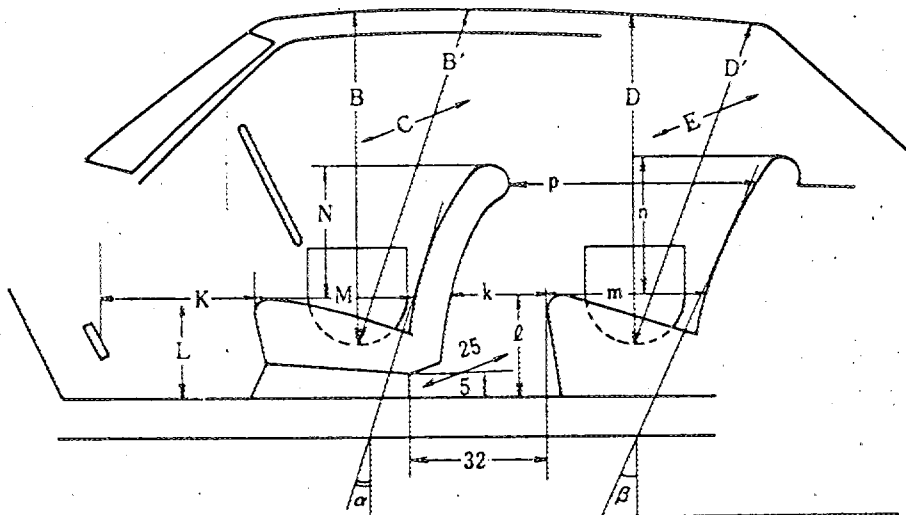

Minimum Dimensions (cm)							
B	B'	$\alpha$	C	D	D'	$\beta$	E
91	98	15°	133.5	92	89	23°	128

Minimum Dimensions (cm)										
L	l	M	m	N	n	k+m	p	k	k+l+m	K+L+M
31	31.5	50	45.5	45.5	42.5	70	83	23	100	120.5
0.9L =	27.9	0.85M =	42.5	0.8N =	36.4	0.8(k+m) =	56	(15)	(95)	(120)

Make Toyota

Model RT71 - K

F.I.A. Rec. No.

TWO STROKE ENGINES

300. System of cylinder scavenging
301. Type of lubrication
302. Inlet ports, length measured around cylinder wall mm inches
303. Height inlet port mm in. 304. Area mm<sup>2</sup> sq. in.
305. Exhaust ports, length measured around cylinder wall mm inches
306. Height exhaust port mm in. 307. Area mm<sup>2</sup> sq. in.
308. Transfer port, length measured around cylinder wall mm inches
309. Height transfer port mm in. 310. Area mm<sup>2</sup> sq. in.
311. Piston ports, length measured around piston mm inches
312. Height piston port mm in. 313. Area mm<sup>2</sup> sq. in.
314. Method of precompression 315. Precompression cyl.: *yes / no*
316. Bore mm inches 317. Stroke mm inches
318. Distance from top of cyl. block to highest point of exhaust port : mm inches
319. Distance from top of cyl. block to lowest point of inlet port : mm inches
320. Distance from top of cyl. block to highest point of transfer port : mm inches
321. Drawing of cylinder ports.

330. Supercharging—state full details hereafter :

JAPAN AUTOMOBILE FEDERATION



Yasuharu Nanba



JAPAN AUTOMOBILE FEDERATION F.I.A. Homol. No

5367

1115

FEDERATION INTERNATIONALE DE L'AUTOMOBILE

Amendment to Form of Recognition Original F.I.A. Recog. in accordance with the International Sporting Code. No

Make Toyota Motor Co., Ltd. Model Toyota Corona Mark II Hardtop, chassis RT71 - 000001 RT71 - K engine 6R 000001 Modification's application starts with serial No. Application of this amendment started the 1st February, 1970 Commercial denomination after application of modifications Toyota Corona Mark II Hardtop SL RT71--S The modifications are to be considered as: Variant / normal / extension of the type Data amendment is valid from 1/10/70 list 70/110

Description of amendment

Photograph A, 3/4 view of car from front

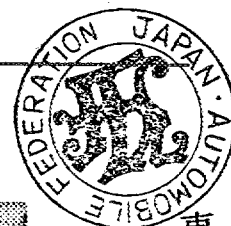
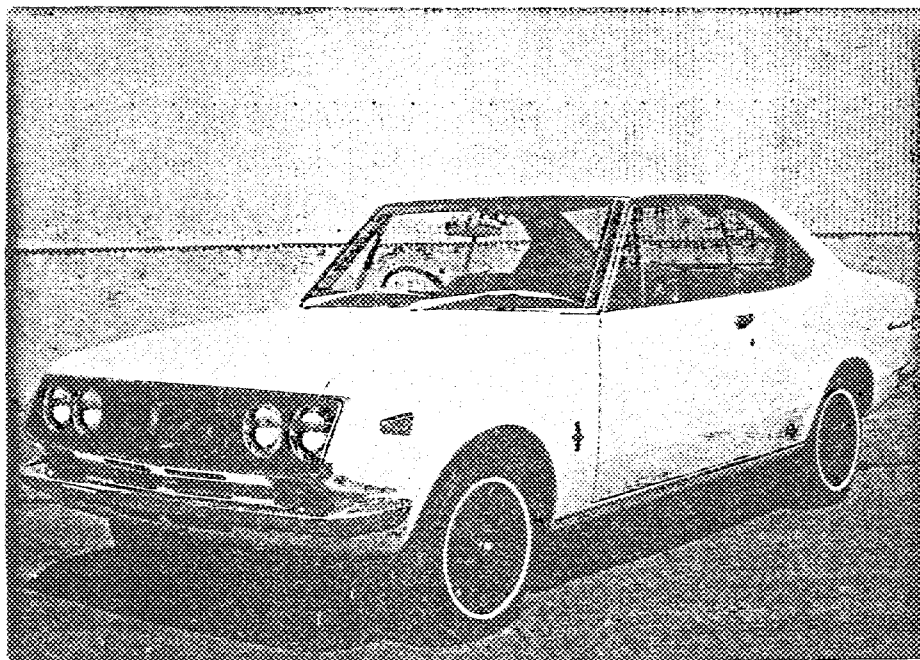

東京都港区芝公園第三号地一番五  
機械振興会館内  
法人 日本自動車連盟

Further detailed specifications are described on the attached sheets

Stamp and signature of National Sporting Authority

Stamp and signature of F.I.A.

JAPAN AUTOMOBILE FEDERATION

Handwritten signature of Yasuharu Nanba

Yasuharu Nanba

Handwritten signature of F.I.A.

Make Toyota

Model

RT71 - S

5567  
1115

ENGINE (Photographs J and K )

142. Compression ratio 9.5

143. Volume of one combustion chamber 50.3  $\text{Cm}^3$

INLET (see page 2 )

186. Tappet clearance for checking timing(cold) 0.15 mm

EXHAUST (see page 2 )

201. Tappet clearance for cheking timing(cold) 0.30 mm

CARBURETION (photograph N )

210. Number of carburettors fitted 2

211. Type Side draught (SU )

212. Make Aisan

213. Model 6R - B

214. Number of mixtue passages per carburettor 1

215. Flange hole diameter of exit port(s) of carburettor 44 mm

216. Minimum dimensions of mixture pasage(s) with piston at

max. hight (example : SU ) 32 mm

ENGINE AND CAR PERFORMANCES(as declared by manufactuer in catalogue)

250. Maximum engine output 105 ps(type of hospower:JIS) at 6000 rpm

251. Maximum rpm 6500 output at that figure 98 ps

252. Maximum torque 14.5 Kg - m at 4000 rpm

253. Maximum speed of the car 170  $\frac{\text{Km}}{\text{hour}}$



Make Toyota

Model RT71 - S

5367  
N1V

Drawing inlet manifold ports, side of cylinder-head. Indicate scale or dimensions and manufacturing tolerance

---

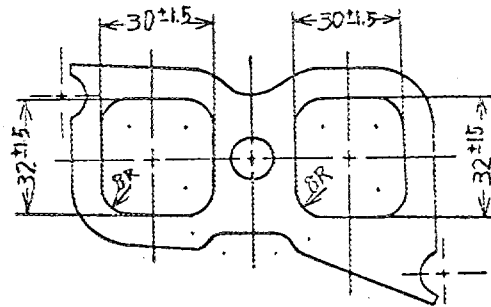

Drawing of entrance to inlet port of cylinder-head. Indicate scale or dimensions and manufacturing tolerance.

---

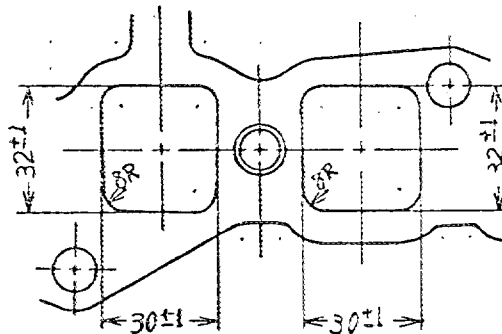

Drawing exhaust manifold ports, side of cylinder-head. Indicate scale or dimensions and manufacturing tolerance.

---

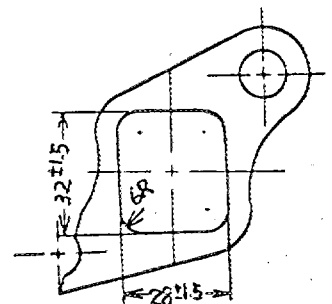
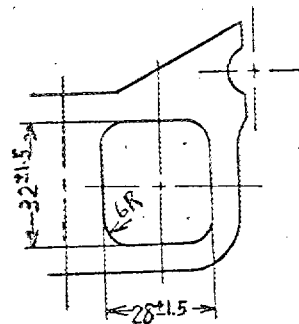

Drawing of exit to exhaust port of cylinderhead. Indicate scale or dimensions and manufacturing

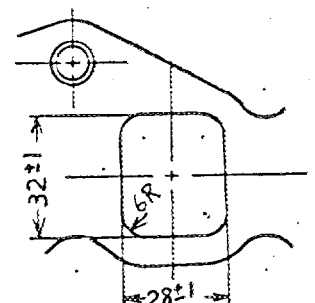
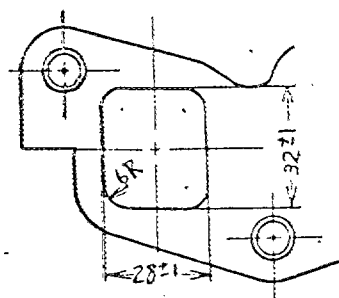

Make Toyota

Model RT71 - S

5367

1/15

Photograph

B,  $\frac{3}{4}$  view of car from rear



C, interior view of car through driver's door (open or removed) with dashboard

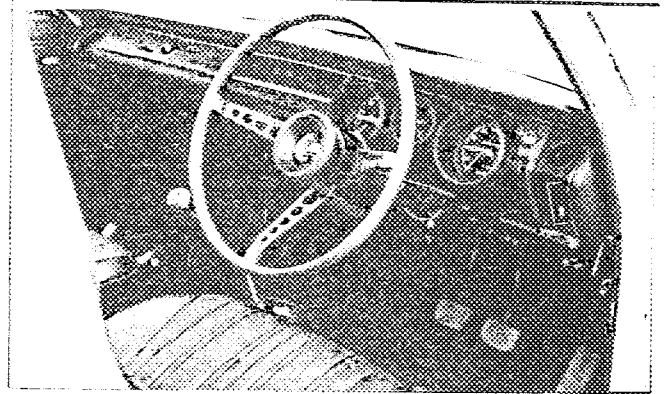

I, silencer + exhaust pipes after exhaust manifold

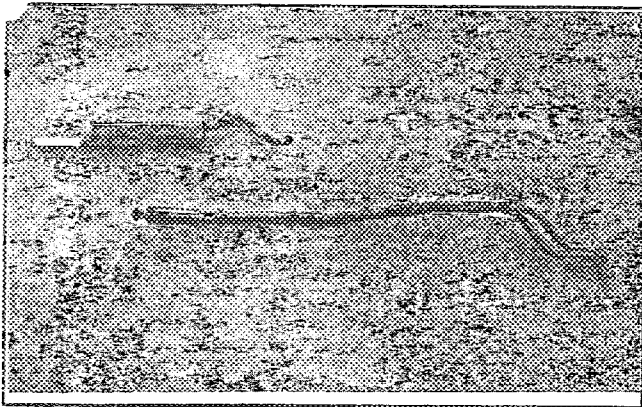

J, engine unit out of car, from right, with clutch and accessories but without air filter nor gear - box.

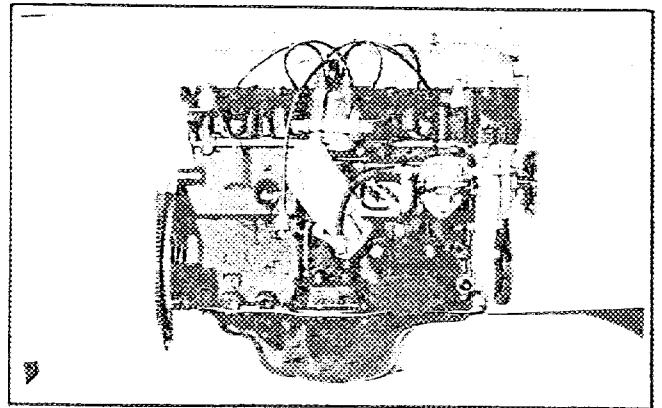

K, engine unit out of car, from left, with clutch and accessories but gear-box nor air filter.

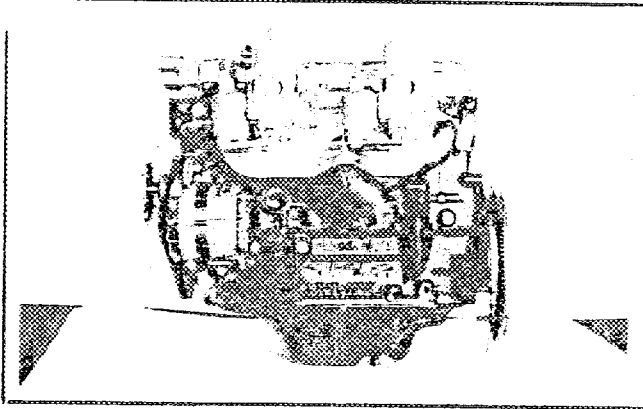

L, combustion chamber

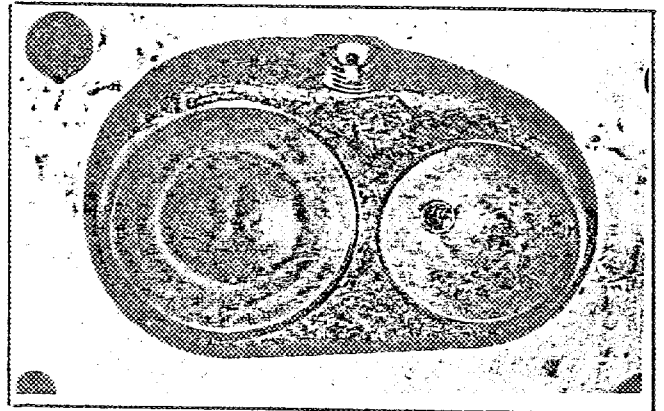

Make Toyota

Model RT71 - S

5367

1/1/5

Photograph

carburettor (view from side of N, manifold )

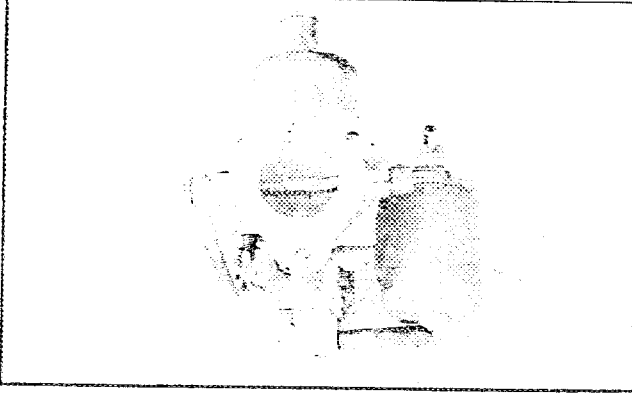

engine in car with all O, accessories, bonnet open or removed.

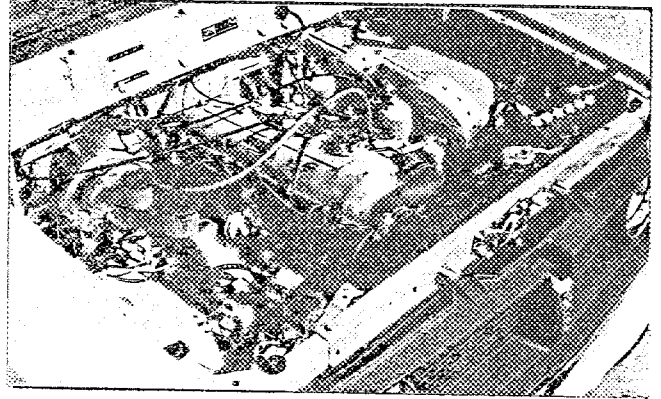

P, inlet manifold

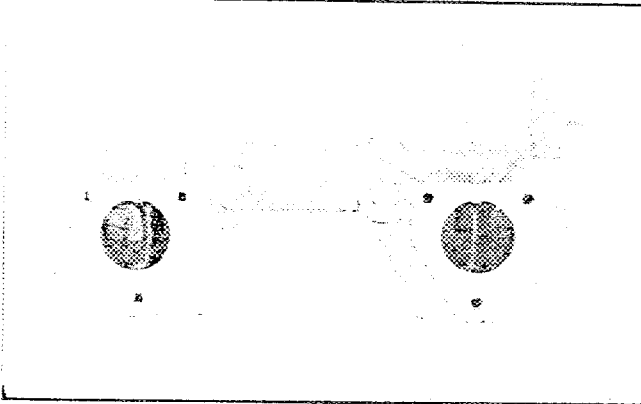

Q, exhaust manifold.

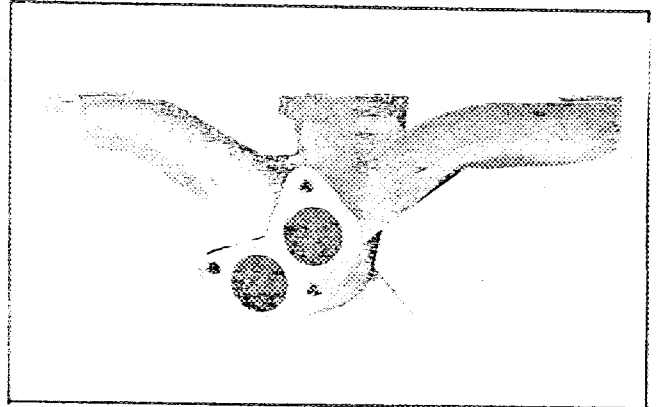

東京都港区芝公園第三号地一番五  
機械振興会館内  
法人 日本

