



JAPAN AUTOMOBILE FEDERATION

F. I. A. Recognition No. **5342**
Group **L**

FEDERATION INTERNATIONALE DE L'AUTOMOBILE

Form of recognition in accordance with
Appendix J to the International Sporting Code.

Manufacturer	Mitsubishi Heavy Industries, Ltd.	Cylinder-capacity	359 cm ³ 21.9 cu. in.
Serial No. of chassis	A 100-000001	Model	Mitsubishi A 100 (MINICA '70)
Serial No. of engine	ME24-000001	Manufacturer	Mitsubishi
Recognition is valid from	1/4/70	Manufacturer	Mitsubishi
		List	70/4

The manufacturing of the model described in this recognition form was started on **April 1969** and the minimum production of **5000** identical cars, in accordance with the specifications of this form was reached on **June 19 69**

Photograph A, 3/4 view of car from front

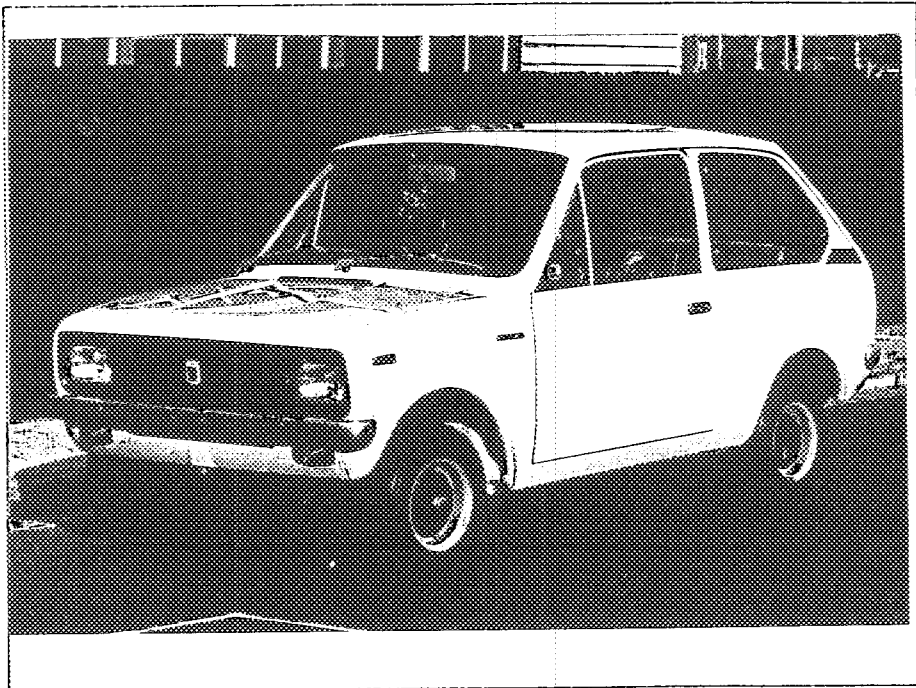

The vehicle described in this form has been subject to the following amendments :

Variants				Normal evolution of the type				
on	19	rec. No.	List	on	19	rec. No.	List	
on	19	rec. No.	List	on	19	rec. No.	List	
on	19	rec. No.	List	on	19	rec. No.	List	
on	19	rec. No.	List	on	19	rec. No.	List	
on	19	rec. No.	List	on	19	rec. No.	List	

Stamp and signature of the
National Sporting Authority

Stamp and signature of the F. I. A.

Make **Mitsubishi**

Model **A100**

F.I.A. Reg. No.

IMPORTANT - The underlined items must be stated in two measuring systems, one of which must be the metric system. See conversion table hereafter.

CAPACITIES AND DIMENSIONS

1. <u>Wheelbase</u>	2000	mm	78.7	inches
2. <u>Front track</u>	1120	mm	44.1	inches *
3. <u>Rear track</u>	1080	mm	42.5	inches *
4. Overall length of the car	299.5	cm		inches
5. Overall width of the car	129.5	cm		inches
6. Overall height of the car	134.5	cm		inches
7. <u>Capacity of fuel tank</u> (reserve included)			25 ltrs	
	6.61	Gallon US		Gallon Imp.
8. Seating capacity	2			
9. <u>Weight</u> , total weight of the car with normal equipment, water, oil and spare wheel but without fuel nor repair tools	420	kg	925	lbs cwt

* Differences in track caused by the use of other wheels with different rim widths must be stated when recognition is requested for the wheels concerned.

Specify ground clearance in relation to the track and give drawing of two fixed points of the vehicle's structure at which measurements are taken.

These ground clearance dimensions are only for information when checking the track and can in no way affect the eligibility of the car.

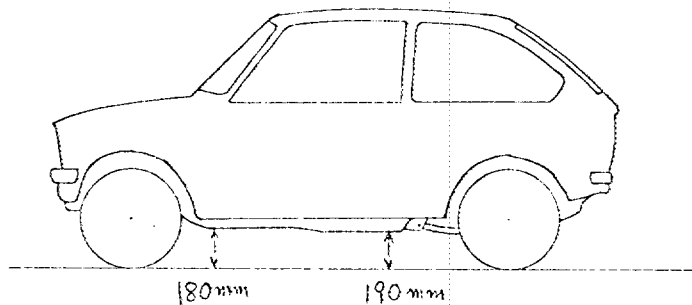

CONVERSION TABLE

1 inch / pouce	-- 2.54 cm	1 quart US	-- 0.9464 ltrs
1 foot / pied	-- 30.4794 cm	1 pint (pt)	-- 0.568 ltrs
1 square inch / pouce carré	-- 6.452 cm ²	1 gallon Imp.	-- 4.546 ltrs
1 cubic inch / pouce cube	-- 16.387 cm ³	1 gallon US	-- 3.785 ltrs
1 pound / livre (lb)	-- 453.593 gr.	1 hundred weight (cwt)	-- 50.802 cwt

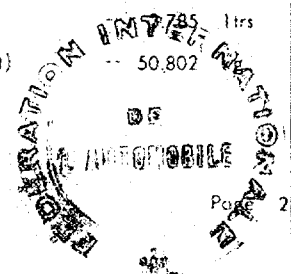

Make **Mitsubishi**

Model **A100**

F.I.A. Rec. No.

CHASSIS AND COACHWORK (Photographs A, B and C)

20. Chassis/body construction : ~~separate~~ / unitary construction
21. Unitary construction, material (s) **Steel**
Separate construction
22. Separate Constructions: Material(s) of chassis
23. Material (s) of coachwork
24. Number of doors **2** Material (s) **Steel**
25. Material (s) of bonnet **Steel**
26. Material (s) of boot lid **Steel**
27. Material (s) of rear-window **Glass**
28. Material (s) of windscreen **Glass**
29. Material (s) of front-door windows **Glass**
30. Material (s) of rear-door windows
31. Sliding system of door windows **Vertical, Manual**
32. Material (s) of rear-quarter light **Glass**

ACCESSORIES AND UPHOLSTERY

38. Interior heating : yes - ~~no~~
39. Air-conditioning : yes - no
40. Ventilation : yes - ~~no~~
41. Front seats, type of seats and upholstery **Separate, Vinyl**
42. Weight of front seat (s), complete with supports and rails, out of the car :
8.5 x 2 kg lbs
43. Rear seats, type of seats and upholstery **Bench, Vinyl**
44. Front bumper, material (s) **Steel** Weight **1.5 kg lbs**
45. Rear bumper, material (s) **Steel** Weight **1.5 kg lbs**

WHEELS

50. Type **Pressed steel**
51. Weight (per wheel, without tyre) **2.3 kg lbs**
52. Method of attachment **4 nuts**
53. Rim diameter **254 mm 10 inches**
54. Rim width **89 mm 3.5 inches**

STEERING

60. Type **Recirculating ball**
61. Servo-assistance : yes - no
62. Number of turns of steering wheel from lock to lock **3.1**
63. In case of servo-assistance



SUSPENSION

- 70. Front suspension (photogr. D), type Independent, McPherson
- 71. Type of spring Coil
- 72. Stabiliser (if fitted) Torsion bar
- 73. Number of shockabsorbers 2
- 74. Type Hydraulic, Telescopic
- 78. Rear suspension (photogr. E), type Rigid
- 79. Type of spring Coil
- 80. Stabiliser (if fitted)
- 81. Number of shockabsorbers 2
- 82. Type Hydraulic, Telescopic

BRAKES (photographs F and G)

- 90. System Hydraulic
- 91. Servo-assistance (if fitted), type
- 92. Number of hydraulic master cylinders 1

	FRONT		REAR	
93. Number of cylinders per wheel	2		1	
94. Bore of wheel cylinder (s)	mm	$\frac{3}{4}$ in.	mm	$\frac{3}{4}$ in.
Drum brakes				
95. Inside diameter	180 mm	in.	180 mm	in.
96. Length of brake linings	156 mm	in.	156 mm	in.
97. Width of brake linings	35 mm	in.	35 mm	in.
98. Number of shoes per brake	2		2	
99. Total area per brake	10900 mm ²	sq. in.	10900 mm ²	sq. in.
Disc brakes				
100. Outside diameter	mm	in.	mm	in.
101. Thickness of disc	mm	in.	mm	in.
102. Length of brake linings	mm	in.	mm	in.
103. Width of brake linings	mm	in.	mm	in.
104. Number of pads per brake				
105. Total area per brake	mm ²	sq. in.	mm ²	sq. in.



Make Mitsubishi

Model A100

F. I. A. Rec. No.

ENGINE (photographs J and K)

- 130. Cycle 2
- 131. Number of cylinders 2
- 132. Cylinder arrangement In line
- 133. Bore 62 mm 2.44 in. 134. Stroke 59.6 mm 2.35 in.
- 135. Capacity per cylinder 179.5 cm³ 10.95 cu. in.
- 136. Total cylinder-capacity 359 cm³ 21.9 cu. in.
- 137. Material (s) of cylinder block Cast iron
- 138. Material (s) of sleeves (if fitted)
- 139. Cylinder-head, material (s) Aluminium alloy Number fitted 2
- 140. Number of inlet ports 2
- 141. Number of exhaust ports 2
- 142. Compression ratio 7.8
- 143. Volume of one combustion chamber 26.4 cm³ cu. in.
- 144. Piston, material Aluminium alloy 145. Number of rings 3
- 146. Distance from gudgeon pin centre line to highest point of piston crown 45 mm inches
- 147. Crankshaft : ~~molded~~ / stamped 148. Type of crankshaft : integral / separate
- 149. Number of crankshaft main bearings 3
- 150. Material of bearing cap
- 151. System of lubrication : dry sump / ~~oil-in-sump~~
- 152. Capacity, lubricant 3 ltrs pts quarts US
- 153. Oil cooler : ~~yes~~ / no 154. Method of engine cooling Air
- 155. Capacity of cooling system ltrs pints quarts US
- 156. Cooling fan (if fitted), dia. 20.5 cm inches
- 157. Number of blades of cooling fan 27

Bearings

center front rear

- 158. Crankshaft, main, type Ball (center, rear) Roller (front) Dia. 25, 28, 30 mm in.
- 159. Connecting rod big end Needle Roller Dia. 22 mm in.

Weights

- 160. Flywheel (clean) 3.2 kg lbs
- 161. Flywheel with clutch (all turning parts) 5.2 kg lbs
- 162. Crankshaft 4.50 kg lbs 163. Connecting rod 0.16 kg lbs
- 164. Piston with rings and pin 0.27 kg lbs



Make Mitsubishi

Model A100

F. I. A. Rec. No

FOUR STROKE ENGINES

- 170. Number of camshafts 171. Location
- 172. Type of camshaft drive
- 173. Type of valve operation

INLET (see page 8) *

- 180. Material(s) of inlet manifold Aluminium alloy
- 181. Diameter of valves mm inches
- 182. Max. valve lift mm in.
- 183. Number of valve springs
- 184. Type of spring
- 185. Number of valves per cylinder
- 186. Tappet clearance for checking timing (cold) mm inches
- 187. Valves open at (with tolerance for tappet clearance indicated)
- 188. Valves close at (with tolerance for tappet clearance indicated)
- 189. Air filter, type Dry

EXHAUST (see page 8)

- 195. Material (s) of exhaust manifold Steel
- 196. Diameter of valves mm inches
- 197. Max. valve lift mm in.
- 198. Number of valve springs
- 199. Type of spring
- 200. Number of valves per cylinder
- 201. Tappet clearance for checking timing (cold) mm inches
- 202. Valves open at (with tolerance for tappet clearance indicated)
- 203. Valves close at (with tolerance for tappet clearance indicated)

CARBURETION (photograph N)

- 210. Number of carburetors fitted 1
- 211. Type Side Draft
- 212. Make MIKUNI
- 213. Model 30 PHD
- 214. Number of mixture passages per carburetor 1
- 215. Flange hole diameter of exit port(s) of carburetor 30 mm in.
- 216. Minimum dimensions of mixture passage (s) ~~with piston at max height (example SU)~~
23 mm inches

INJECTION (if fitted)

- 220. Make of pump
- 221. Number of plungers
- 222. Model or type of pump
- 223. Total number of injectors
- 224. Location of injectors
- 225. Minimum diameter of inlet pipe mm inches

*) for additional information concerning two-stroke engines and super-charged engines see page 13.

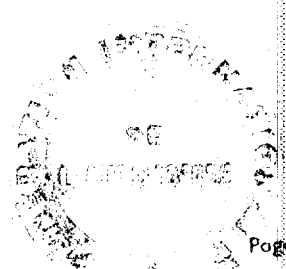

Make Mitsubishi

Model A100

F. I. A. Reg. No.

ENGINE ACCESSORIES

- 230. Fuel pump : mechanical ~~and / or electric~~
- 231. No. fitted 1
- 232. Type of ignition system **Make and break**
- 233. No. of distributors
- 234. No. of ignition coils **2**
- 235. No. of spark plugs per cylinder **1**
- 236. Generator, type: dynamo/~~alternator~~-number fitted **1**
- 237. Method of drive **Direct**
- 238. Voltage of generator **12** volts
- 239. Battery, number **1**
- 240. Location **Engine room**
- 241. Voltage of battery **12** volts

ENGINE AND CAR PERFORMANCES (as declared by manufacturer in catalogue)

- 250. Max. engine output **26 PS** (type of horsepower: **JIS**) at **5500** rpm
- 251. Maximum rpm **6500** output at that figure **23.5 PS**
- 252. Maximum torque **3.6 kgm** at **4500** rpm
- 253. Maximum speed of the car **105** km/hour **miles / hour**

255.

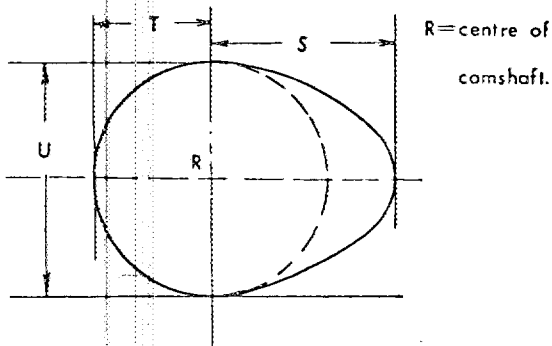

Inlet cam

- S = mm inches
- T = mm inches
- U = mm inches

Exhaust cam

- S = mm inches
- T = mm inches
- U = mm inches

Make Mitsubishi

Model A100

F. I. A. Rec. No.

Drawing inlet manifold ports, side of cylinder-head. Indicate scale or dimensions and manufacturing tolerance.

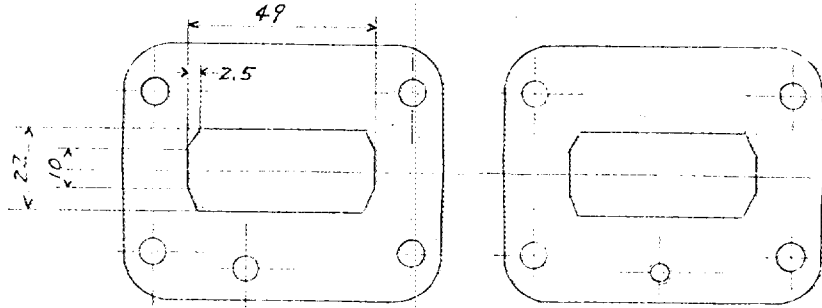

Drawing of entrance to inlet port of cylinder-head. Indicate scale or dimensions and manufacturing tolerance.

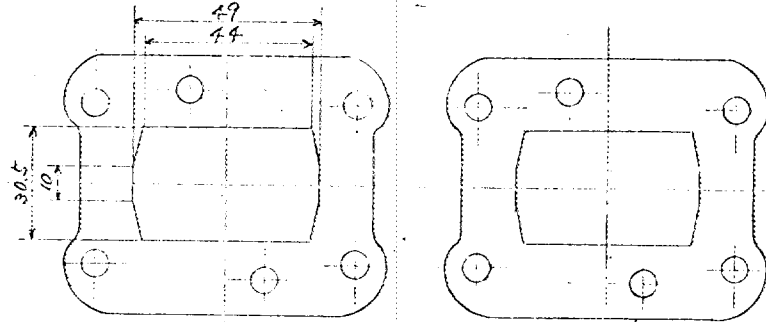

Drawing exhaust manifold ports, side of cylinder-head. Indicate scale or dimensions and manufacturing tolerance.

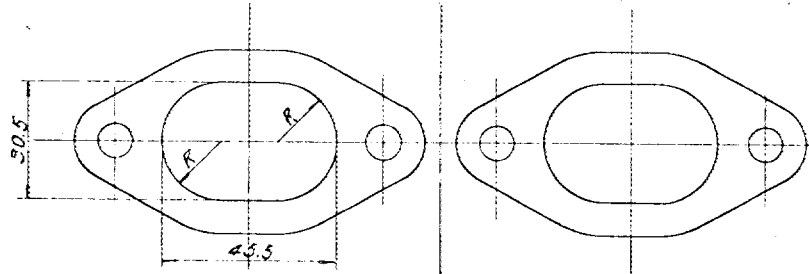

Drawing of exit exhaust port of cylinderhead. Indicate scale or dimensions and manufacturing tolerance.

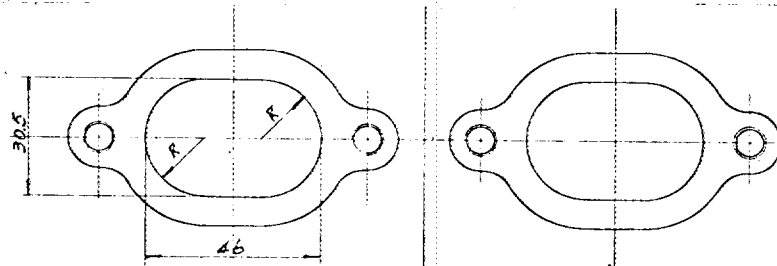

Tolerance ; ± 1.5
Unit ; mm



Make Mitsubishi

Model A100

F. I. A. Rec. No.

DRIVE TRAIN

CLUTCH

- 260. Type of clutch Single dry 261. No. of plates 1
- 262. Dia. of clutch plates 15 cm inches
- 263. Dia. of linings, inside 11 cm in. outside 15 cm in.
- 264. Method of operating clutch Mechanical

GEAR BOX (photograph H)

- 270. Manual type, make Mitsubishi Method of operation Mechanical
- 271. No. of gear-box ratios forward 4 272. Synchronized forward ratios 1, 2, 3, 4
- 273. Location of gear-shift Floor
- 274. Automatic, make type
- 275. No. of forward ratios 276. Location of gear-shift

277.	Manual		Automatic		Alternative manual Automatic		
	Ratio	No. teeth	Ratio	No. teeth	Ratio	No. teeth	Ratio No. teeth
1	3.576				3.576		
	$\frac{33}{17} \times \frac{35}{19}$					$\frac{33}{17} \times \frac{35}{19}$	
2	2.265				2.096		
	$\frac{33}{17} \times \frac{28}{24}$					$\frac{33}{17} \times \frac{27}{25}$	
3	1.473				1.359		
	$\frac{33}{17} \times \frac{22}{29}$					$\frac{33}{17} \times \frac{21}{30}$	
4	1.000				1.000		
5							
6							
reverse	$\frac{33}{17} \times \frac{17}{15} \times \frac{33}{17}$				4.271		$\frac{33}{17} \times \frac{17}{15} \times \frac{33}{17}$

- 278. Overdrive, type
- 279. Forward gears on which overdrive can be selected
- 280. Overdrive ratio

FINAL DRIVE

- 290. Type of final drive Hypoid
- 291. Type of differential Bevel gear
- 292. Type of limited slip differential (if fitted)
- 293. Final drive ratio 5.429, 5.833
- Number of teeth $\frac{38}{7}$, $\frac{35}{6}$

Make **Mitsubishi**

Model **A100**

F. I. A. Rec. No.

IMPORTANT: The conformity of the car with the following items of the present recognition form is to be disregarded during the scrutineering, when the vehicle has been entered in group 2 (Touring cars) or 3 (Grand Touring cars) : 41, 72, 80, 91, 142, 143, 144, 145, 146, 153, 156, 157, 160, 161, 162, 163, 164, 182, 184, 186, 187, 188, 189, 199, 201, 202, 203, 212, 213, 215, 216, 222, 225, 230, 250, 251, 252, 253, and photographs I, M, N, and page 8

During the scrutineering of cars entered in group 4 (Sportscars) only the following items of the present recognition form are to be taken into consideration : 1, 2, 3, 9, 20, 21, 22, 23, 24, 25, 26, 70, 71, 78, 79, 90, 130, 131, 132, 133, 134, 135, 136, 137, 138, 139, 140, 141, 147, 148, 149, 150, 158, 159, 170, 171, 172, 173, 185, 200, 270, 271, 274, 275, 290, 291, 292 and photographs A, B, D, E, F, G, H, J, K, and O.

Optional equipment affecting preceding information. This to be stated together with reference number.

Photograph

B, 3/4 view of car from rear

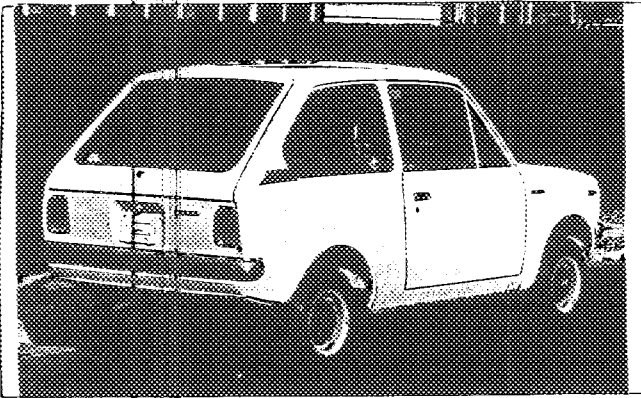

C, interior view of car through driver's door (open or removed) with dashboard

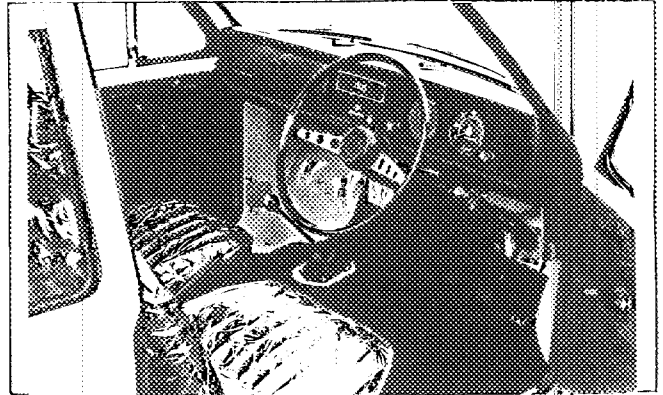

D, front axle complete, removed from car. Without wheels.

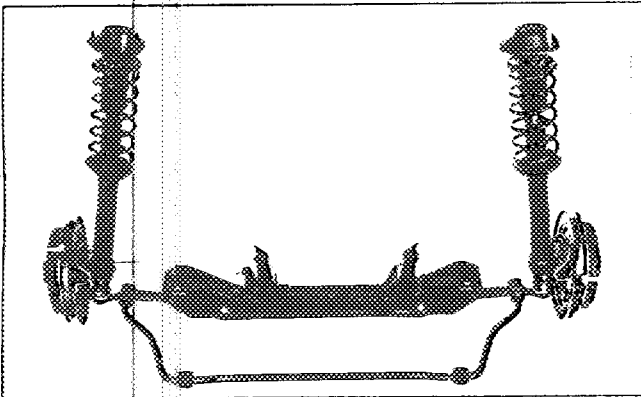

E, Rear axle complete without wheels, removed from car.

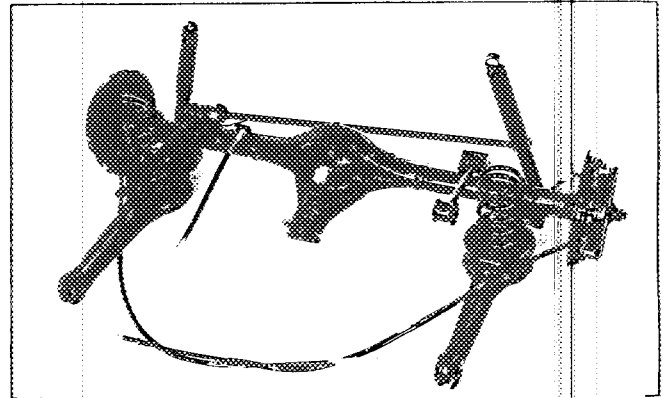

F, front brake, drum removed or disc with caliper(s)

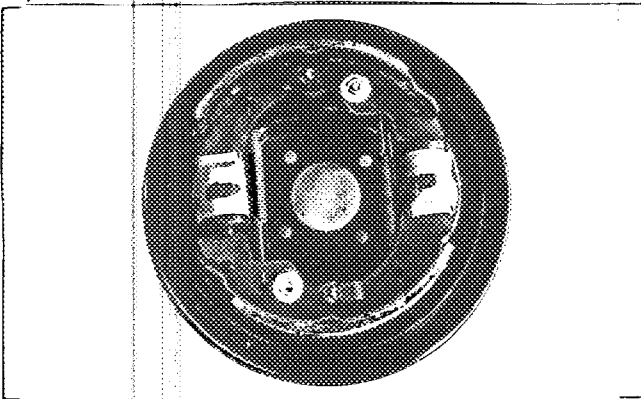

G, rear brake, drum removed or disc with caliper(s)

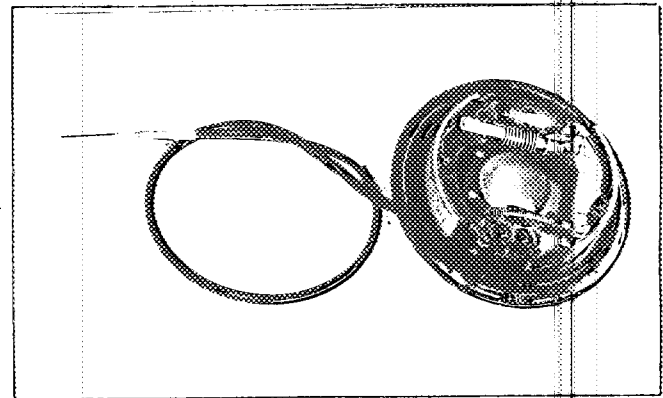

H, gear-box, view from side

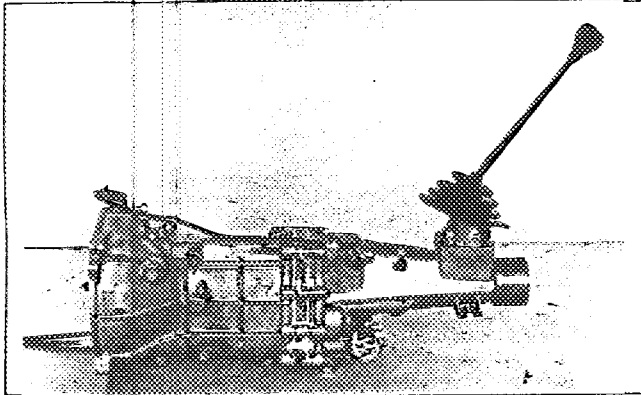

I, silencer + exhaust pipes after exhaust manifold

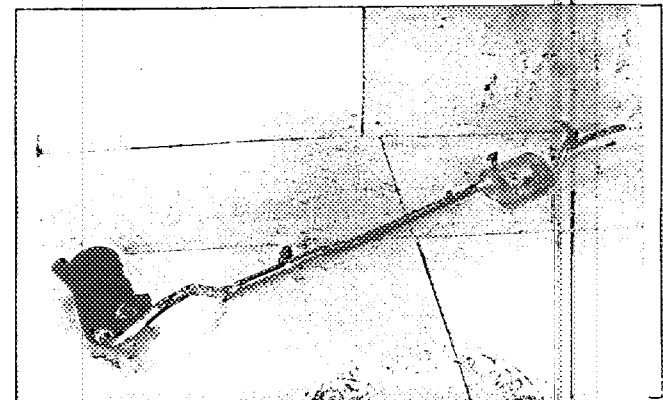

Make Mitsubishi

Model A100
Photograph

F. I. A. Rec. No

engine unit out of car, from right. With clutch and J accessories but without air filter nor gear-box.

Engine unit out of car, from left. With clutch and K accessories but without gear-box nor air filter.

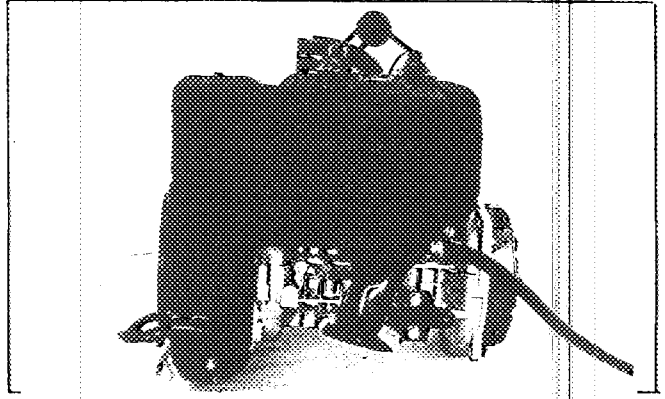
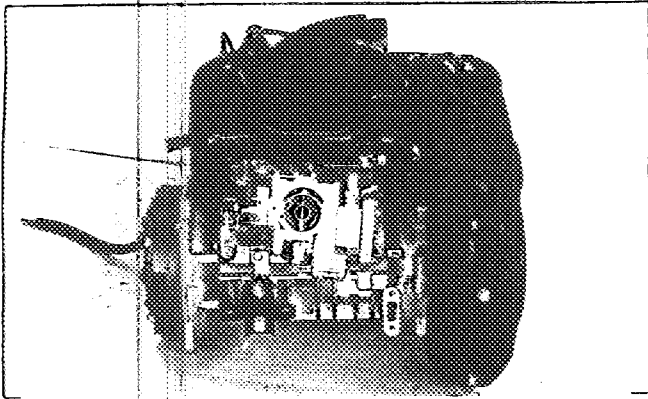

L, combustion chamber

M, piston crown

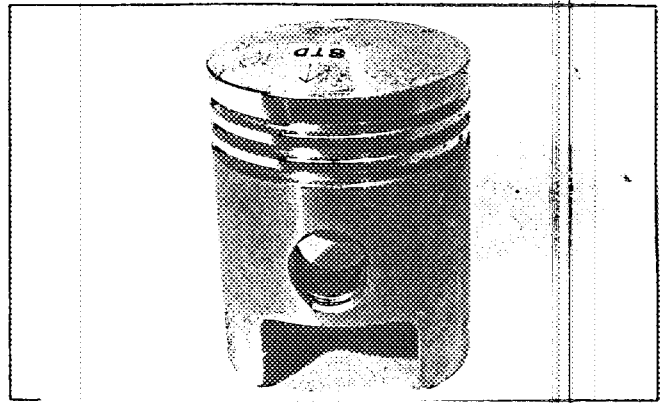
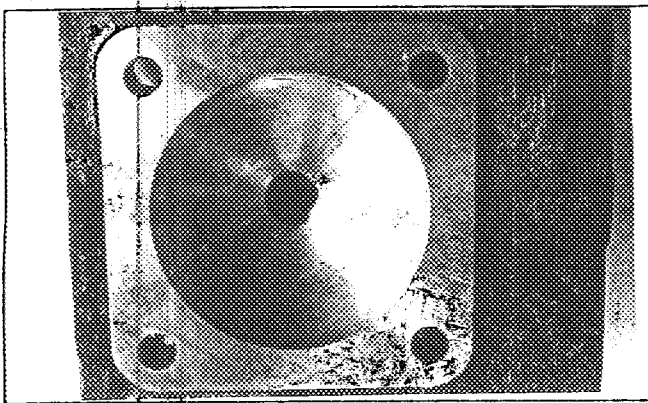

N, Carburetor (view from side of manifold)

O, engine in car with all accessories, bonnet open or removed.

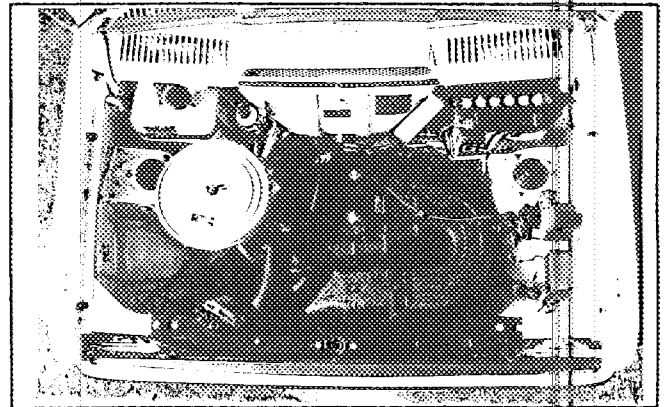
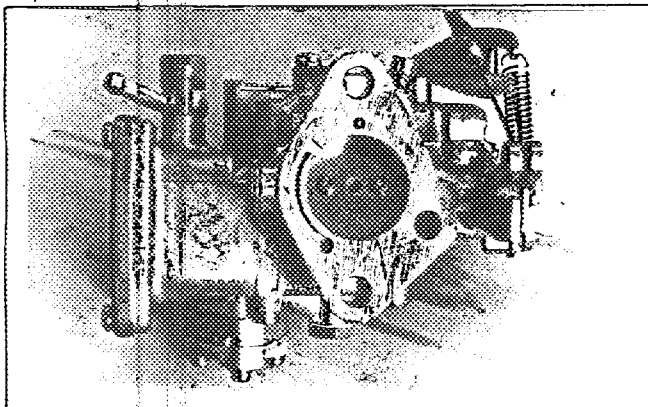

P, inlet manifold

Q, exhaust manifold

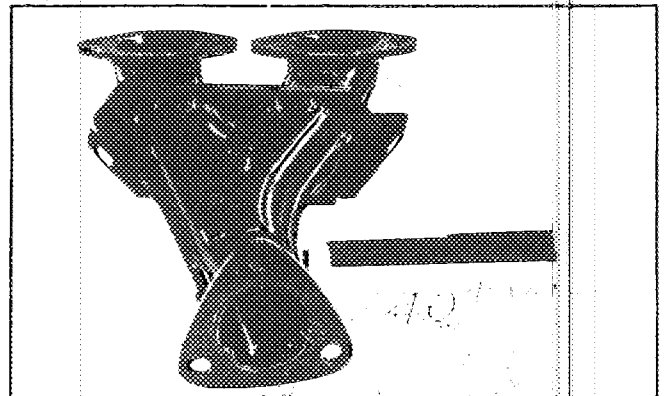
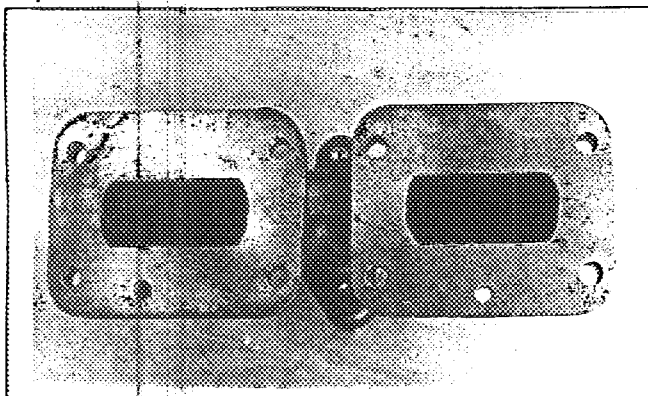

DIMENSIONS OF INTERIOR
(Conform to Art. 253 b of Appendix JI)

For two seats:

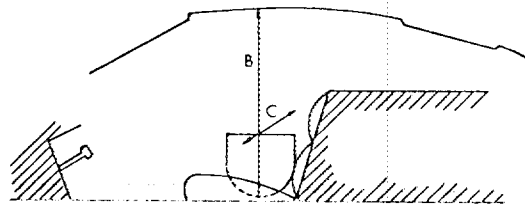

Minimum Dimensions	
B	C
94 cm	111 cm



Make Mitsubishi

Model A100

F.I.A. Res. No.

TWO STROKE ENGINES

- 300. System of cylinder scavenging Loop type
- 301. Type of lubrication Auto-mix
- 302. Inlet ports, length measured around cylinder wall Reed valve type mm inches
- 303. Height inlet port mm in. 304. Area mm² sq. in.
- 305. Exhaust ports, length measured around cylinder wall 38 mm inches
- 306. Height exhaust port 20 mm in. 307. Area 654 mm² sq. in.
- 308. Transfer port, length measured around cylinder wall 2 x 32 mm inches
- 309. Height transfer port 11.4 mm in. 310. Area. 2 x 356 mm² sq. in.
- 311. Piston ports, length measured around piston mm inches
- 312. Height piston port mm in. 313. Area mm² sq. in.
- 314. Method of precompression Crank case 315. Precompression cyl.: yes/no
- 316. Bore 62 mm inches
- 317. Stroke 59.6 mm inches
- 318. Distance from top of cyl. block to highest point of exhaust port : 43.8 mm inches
- 319. Distance from top of cyl. block to lowest point of inlet port : mm inches
- 320. Distance from top of cyl. block to highest point of transfer port : 50.4 mm inches
- 321. Drawing of cylinder ports.

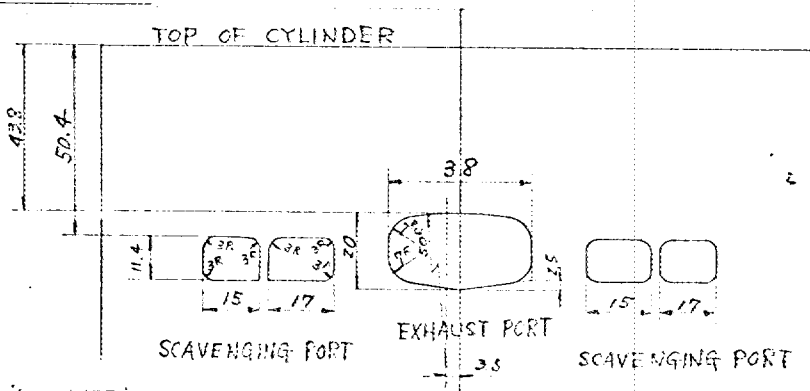

Tolerance: ± 1.5
Unit: mm

330. Supercharging—state full details hereafter :

JAPAN AUTOMOBILE FEDERATION

廣山博史

Hiroshi Niwayama