



F.I.A. Recognition No. 5336
Group I

ROYAL AUTOMOBILE CLUB

31 Belgrave Square, London, SW1X 8QH

Form of recognition in accordance with appendix J to the International Sporting Code of the
FEDERATION INTERNATIONALE DE L'AUTOMOBILE

	<u>Cylinder-capacity</u> <u>2994</u> cm. ³ <u>182.7</u> in. ³
Manufacturer <u>FORD MOTOR COMPANY LIMITED</u>	Model <u>CAPRI 3 LITRE</u>
Serial No. of chassis/body <u>BBECKL 20391</u>	Manufacturer <u>FORD</u>
Serial No. of engine <u>-</u>	Manufacturer <u>FORD</u>
Recognition is valid from <u>1st APRIL 1970</u>	List <u>70/4</u>
The manufacturing of the model described in this recognition form started on <u>18 December</u> <u>1969</u>	
and the minimum production of <u>5000</u> identical cars, in accordance with the specifications of	
this form was reached on <u>16 February</u> <u>1970</u>	

Photograph A. $\frac{1}{4}$ view of car from front



F.I.A. Stamp



R.A.C. Stamp

B



C



D

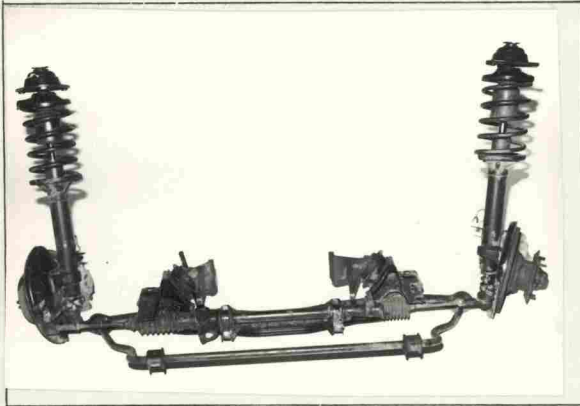

E

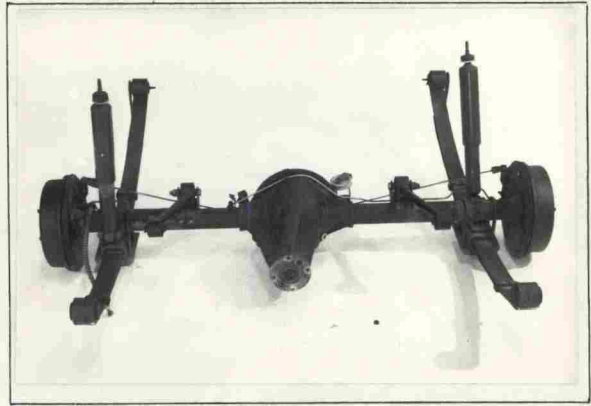

F



G

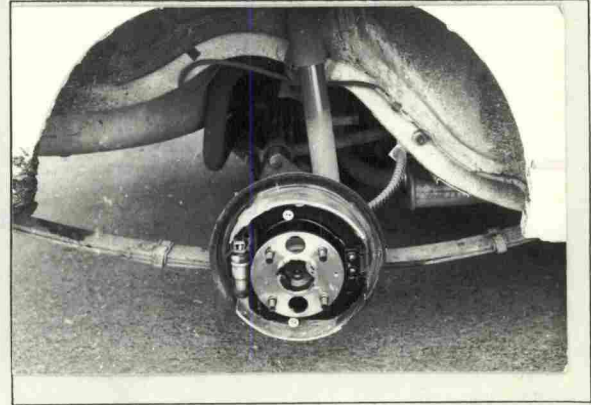

H

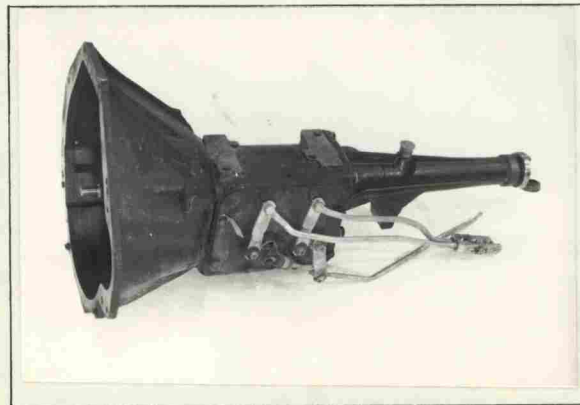

I

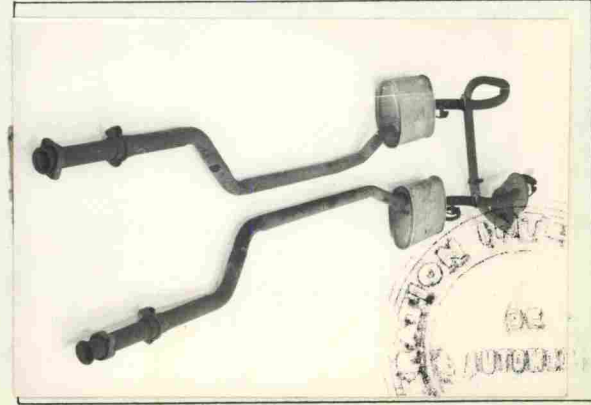

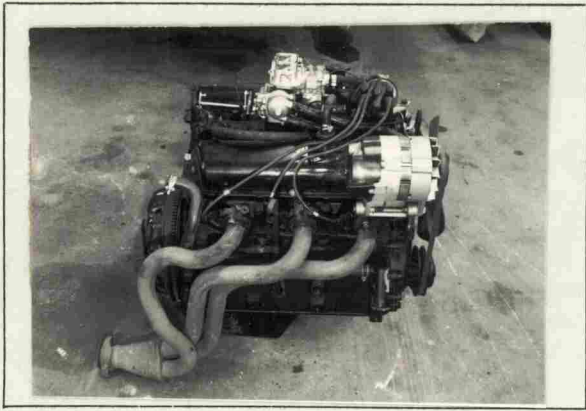

J

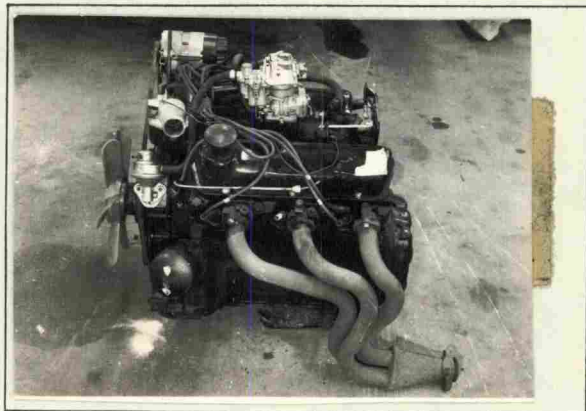

K

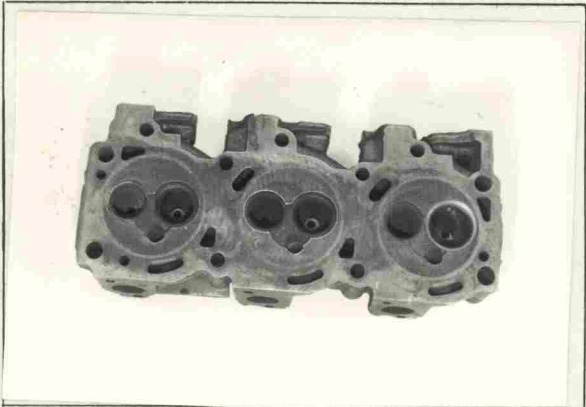

L

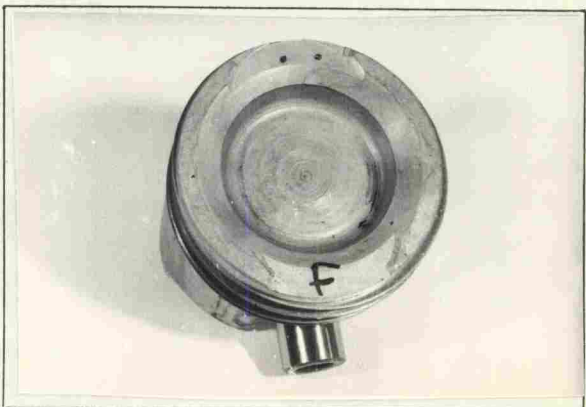

M

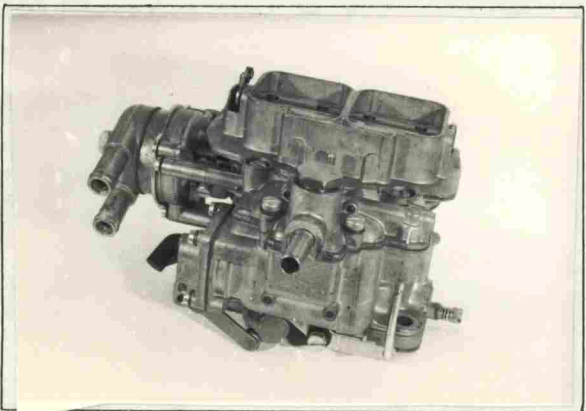

N

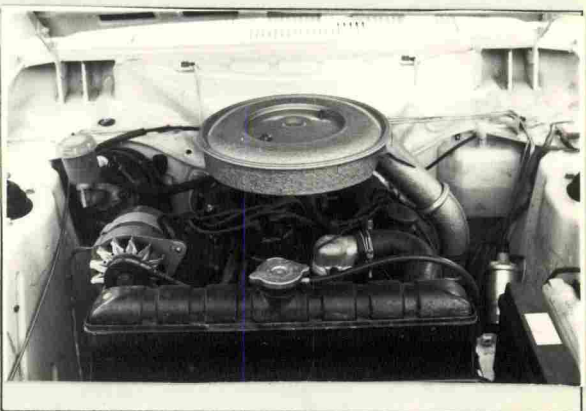

O

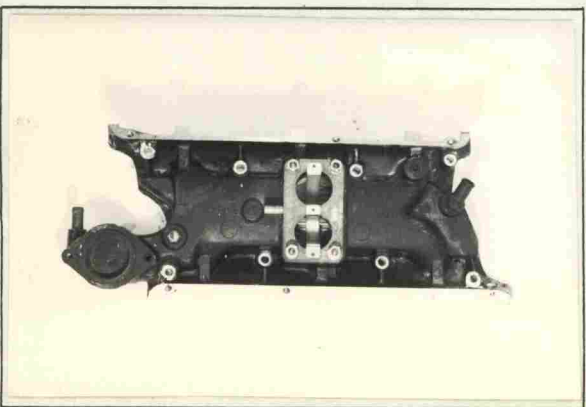

P

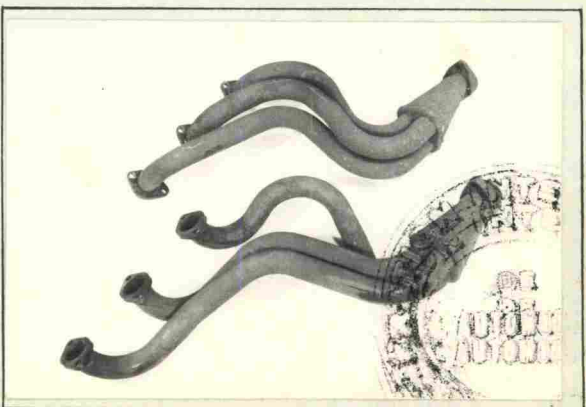

Q

Make FORD

Model CAPRI 3 LITRE

F.I.A. Rec. No.

Drawing inlet manifold ports, side of cylinderhead. Indicate scale or dimensions and manufacturing tolerance.

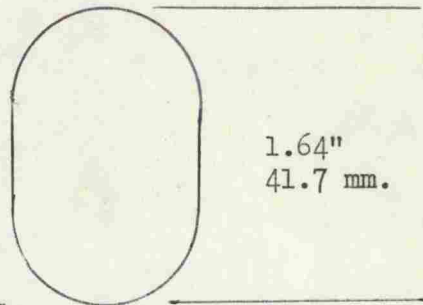

1.64"
41.7 mm.

Drawing of entrance to inlet port of cylinderhead. Indicate scale or dimensions and manufacturing tolerance.

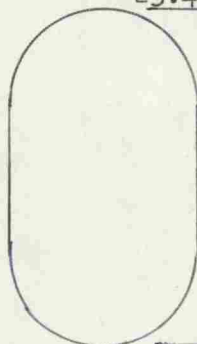

0.92 ins
23.4 mm. 0.84 ins.
21.3 mm.

1.72 ins.
43.7 mm.

Drawing of exhaust manifold ports, side of cylinderhead. Indicate scale or dimensions and manufacturing tolerance.

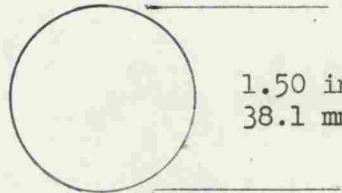

1.50 ins.
38.1 mm.

Drawing of exit to exhaust port of cylinderhead. Indicate scale or dimensions and manufacturing tolerance.

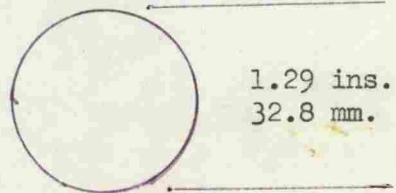

1.29 ins.
32.8 mm.

All dimensions \pm .040 ins
1.016 mm.



Make FORD

Model CAPRI 3 LITRE

F.I.A. Rec. No. _____

NOTE 1.

All dimensions must be given in two measuring systems, see Note 3.

CAPACITIES AND DIMENSIONS

1. Wheelbase		2560.3 mm.	$\pm 50.0\text{mm.}$	100.8 inches
2. Front track	$\pm 25.4\text{mm.}$	1371.6 mm.	$\pm 1.0\text{ ins.}$	54.0 inches
3. Rear track		1346.2 mm.	$\pm 25.4\text{ mm.}$	$\pm 1.0\text{ ins.}$ 53.0 inches

Measurement from rocker panel to road

FRONT	See Note 2	REAR
7.5 ins.		7.5 ins.



4. Overall length of the car		426.2 cm.	167.8 inches
5. Overall width of the car		169.9 cm.	66.8 inches
6. Overall height of the car		149.8 cm.	50.9 inches
7. Capacity of fuel tank (reserve included)		61.37 ltrs.	16.21 gall. U.S. 13.5 gall. Imp.
8. Seating Capacity.	4		
9. Weight. Total weight of the car with normal equipment, water, oil, and spare wheel but without fuel or repair tools :		1001.8 kg.	2208.6 lbs. 19.72 cwts.

NOTE 2.

Differences in track caused by the use of other wheels with different rim widths must be stated when recognition is requested for the wheels concerned. Specify ground clearance in relation to the track and give drawing of two easily recognisable points at front and rear at which measurements are taken. These ground clearance dimensions are only for information when checking the track and can in no way affect the eligibility of the car.

NOTE 3.

CONVERSION TABLE

1 inch/pouce	— 2.54	cm.	1 quart US	— 0.9464	ltrs.
1 foot/pied	— 30.4794	cm.	1 pint (pt)	— 0.568	ltrs.
1 sq. inch/pouce carre	— 6.452	cm. ²	1 gallon Imp.	— 4.546	ltrs.
1 cubic inch/pouce cube	— 16.387	cm. ³	1 gallon US	— 3.785	ltrs.
1 pound/livre (lb)	— 453.593	gr.	1 hundred weight (cwt.)	— 50.802	kg.

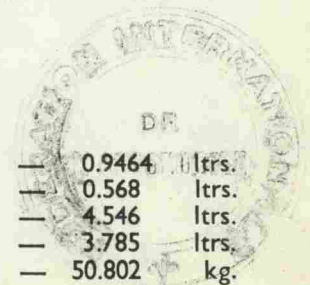

CHASSIS AND COACHWORK (Photographs A, B and C)

- 20. Chassis/body construction: ~~separate~~/unitary construction
- 21. Unitary construction, material(s) Steel
- 22. Separate construction, Material(s) of chassis Steel
- 23. Material(s) of coachwork Steel
- 24. Number of doors 2 Material(s) Steel
- 25. Material(s) of bonnet Steel
- 26. Material(s) of boot lid Steel
- 27. Material(s) of rear-window Toughened glass
- 28. Material(s) of windscreen Toughened or Laminated glass
- 29. Material(s) of front-door windows Toughened glass
- 30. Material(s) of rear-door windows N/A
- 31. Sliding system of door windows Rotating handle
- 32. Material(s) of rear-quarter light Toughened glass

ACCESSORIES AND UPHOLSTERY

- 38. Interior heating : yes — no Optional
- 39. Air conditioning : ~~yes~~ — no
- 40. Ventilation : yes — ~~no~~
- 41. Front seats, type of seat and upholstery Bucket
PVC or cloth
- 42. Weight of front seat(s), complete with supports and rails, out of the car :
12.2 kg. 27 lbs.
- 43. Rear seats, type of seat and upholstery Bench PVC or cloth
- 44. Front bumper, material(s) Steel Weight 2.5 kg. 5.5 lbs.
- 45. Rear bumper, material(s) Steel Weight 2.5 kg. 5.5 lbs.

WHEELS

- 50. Type Pressed steel disc
- 51. Weight (per wheel, without tyre) 5.8 kg. 12 lbs.
- 52. Method of attachment 4 Taper nut fixing
- 53. Rim diameter 330.2 mm. 13 ins. 54. Rim width 127.0 mm. 5 ins.

STEERING

- 60. Type Rack and Pinion
- 61. Servo-assistance : yes — no N/A
- 62. Number of turns of steering wheel from lock to lock 3.2 approx,
- 63. In case of servo-assistance N/A



Make FORD

Model CAPRI 3 LITRE

F.I.A. Rec. No.

SUSPENSION

- 70. Front suspension (photograph D), type Independent McPherson Strut
- 71. Type of spring Coil
- 72. Stabiliser (if fitted) Integral with Lower Arms
- 73. Number of shock absorbers 2
- 74. Type Integral Suspension Leg, Telescopic Double Acting
- 78. Rear suspension (photograph E), type Live Axle
- 79. Type of spring Multi-Leaf Semi-Elliptic
- 80. Stabiliser (if fitted) Trailing Links
- 81. Number of shock absorbers 2
- 82. Type Telescopic Double Acting

BRAKES (photographs F and G)

- 90. Method of operation Hydraulic
- 91. Servo-assistance (if fitted), type Hydraulic Vacuum
- 92. Number of hydraulic master cylinders One

	2 FRONT		1 REAR	
93. Number of cylinders per wheel				
94. Bore of wheel cylinder(s)	54.0 mm.	2.126 inches	19.05 mm.	0.75 inches

Drum Brakes

95. Inside diameter	mm.	inches	228.6 mm.	9.00 inches
96. Length of brake linings	mm.	inches	218.9 mm.	8.62 inches
97. Width of brake linings	mm.	inches	44.45 mm.	1.75 inches
98. Number of shoes per brake			2	
99. Total area per brake	mm. ²	sq. in.	1946.4 mm. ²	30.17 sq. in.

Disc Brakes

100. Outside diameter	244.0 mm.	9.6 inches	mm.	inches
101. Thickness of disc	12.7 mm.	.5 inches	mm.	inches
102. Length of brake linings	76.2 mm.	3.0 inches	mm.	inches
103. Width of brake linings	53.34 mm.	2.1 inches	mm.	inches
104. Number of pads per brake	2			
105. Total area per brake	667.0 mm. ²	10.34 sq. in.	mm. ²	sq. in.

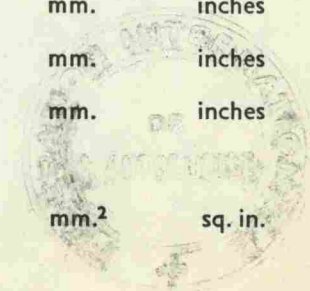

Make FORD

Model CAPRI 3 LITRE

F.I.A. Rec. No.

ENGINE (photographs J and K)

- 130. Cycle Four Stroke
- 131. Number of cylinders 6
- 132. Cylinder Arrangement V formation, banks of 3
- 133. Bore 93.67 mm. 3.687 in.
- 134. Stroke 72.42 mm. 2.851 in.
- 135. Capacity per cylinder 499 cm.³ 30.45 cu. in.
- 136. Total cylinder capacity 2994 cm.³ 182.7 cu. in.
- 137. Material(s) of cylinder block Cast iron
- 138. Material(s) of sleeves (if fitted) None
- 139. Cylinder head, material(s) Cast iron
- Number fitted 2
- 140. Number of inlet ports 6
- 141. Number of exhaust ports 6
- 142. Compression ratio 8.9 : 1 ± .3
- 143. Volume of one combustion chamber 58.48 cm.³ 3.568 cu. in.
- 144. Piston, material Aluminium alloy
- 145. Number of rings 3
- 146. Distance from gudgeon pin centre line to highest point of piston crown 46.1 mm. 1.8 in.
- 147. Crankshaft : moulded/~~stamped~~
- 148. Type of crankshaft: integral/Cast with balance weights
- 149. Number of crankshaft main bearings 4
- 150. Material of bearing cap Cast iron
- 151. System of lubrication : ~~dry sump~~/oil in sump
- 152. Capacity, lubricant 5.6 ltrs. 9.8 pts. 5.9 quarts U.S.
- 153. Oil cooler : ~~yes~~/no
- 154. Method of engine cooling Water and fan
- 155. Capacity of cooling system 11.2 ltrs. 19.7 pts. 11.6 quarts U.S. including heater if fitted
- 156. Cooling fan (if fitted) dia. 30.48 cm. 12 in.
- 157. Number of blades of cooling fan 6

Bearings

- 158. Crankshaft main, type) Copper lead or dia. 63.52 m.m. 2.5016 in.
- 159. Connecting rod big end, type) aluminium tin dia. 60.36 m.m. 2.3765 in.

Weights

- 160. Flywheel (clean) 9.5 kg. 21 lbs.
- 161. Flywheel with clutch (all turning parts) 17.25 kg. 38 lbs.
- 162. Crankshaft 18 kg. 40 lbs.
- 163. Connecting rod .74 kg. 1.72 lbs.
- 164. Piston with rings and pin .75 kg. 1.73 lbs.

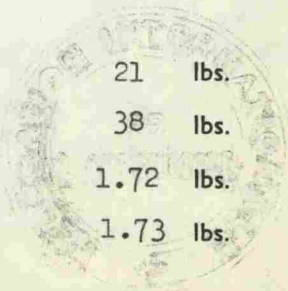

Make FORD

Model CAPRI 3 LITRE

F.I.A. Rec. No.

IMPORTANT :

During the scrutineering of cars entered in group 5 (Sportscars) only the following items of the present recognition form are to be taken into consideration : 1, 2, 3, 9, 20, 21, 22, 23, 24, 25, 26, 70, 71, 78, 79, 90, 130, 131, 132, 133, 134, 135, 136, 137, 138, 139, 140, 141, 147, 148, 149, 150, 158, 159, 170, 171, 172, 173, 185, 200, 270, 271, 274, 275, 290, 291, 292 and photographs A, B, D, E, F, G, H, J, K and O.

The vehicle described in this form has been subject to the following amendments :

on.....	19.....	rec. no.....	List.....	on.....	19.....	rec. no.....	List.....
on.....	19.....	rec. no.....	List.....	on.....	19.....	rec. no.....	List.....
on.....	19.....	rec. no.....	List.....	on.....	19.....	rec. no.....	List.....
on.....	19.....	rec. no.....	List.....	on.....	19.....	rec. no.....	List.....
on.....	19.....	rec. no.....	List.....	on.....	19.....	rec. no.....	List.....

Optional equipment affecting preceding information. This to be stated together with reference number.

Manufacturing Tolerances :

1. For all machined surfaces allow 0.75%
2. For all non-machined surfaces allow 3%
3. For weights of all part machined parts allow 2.5%
4. For weights of all fully machined parts allow 1.75%





MOTOR SPORT DIVISION
The Royal Automobile Club,
31 Belgrave Square, London, S.W.1

Manufacturer FORD
Model CAPRI 3 LITRE
F.I.A. Recognition No. _____
Amendment No. 1

Amendment to Form of Recognition

FEDERATION INTERNATIONALE DE L'AUTOMOBILE

No.

Reference No.

GROUP II VARIANT

Five-speed Gearbox ZF
Part No: CD 70/4

- 270. Manual type make ZF
Method of operation : manual
- 271. Number of gearbox ratios forward (5) five
- 272. Synchronized forward ratios (5) five
- 273. Location of gear shift, remote control floor control
- 278. Overdrive : A gear ratio for the 5th position gives
overdrive ratio if desired.

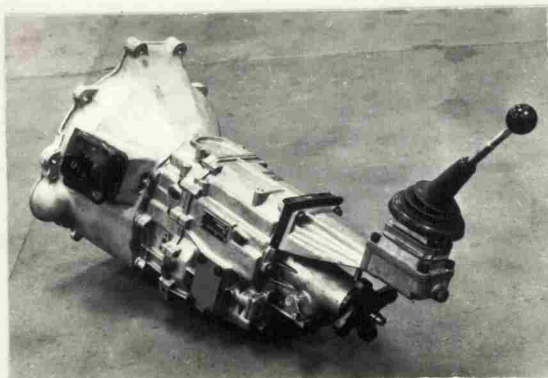

Date amendment is valid from _____

Stamp of F.I.A./R.A.C.





MOTOR SPORT DIVISION
The Royal Automobile Club,
31 Belgrave Square, London, S.W.1

Manufacturer FORD

Model CAPRI 3 LITRE

F.I.A. Recognition No. 5336

Amendment No. 1/10 GR II

Amendment to Form of Recognition

FEDERATION INTERNATIONALE DE L'AUTOMOBILE

No.

Reference No.

VARIANT GROUP II

Fibreglass Bonnett - Part No. H69EB 16612AA

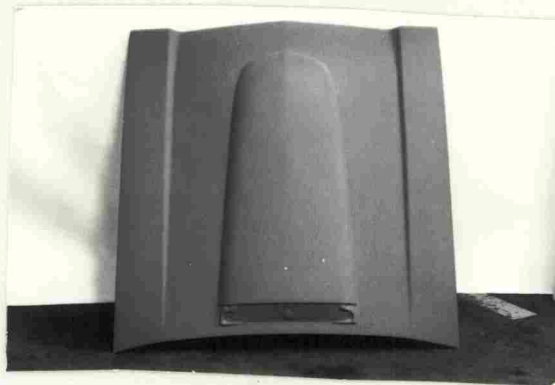

Fibreglass Boot - Part No. H69EB 7040112AA

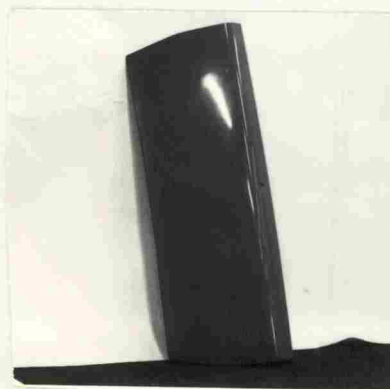

Date amendment is valid from 1/10/70 70/10

Stamp of F.I.A./R.A.C.



MOTOR SPORT DIVISION
The Royal Automobile Club,
31 Belgrave Square, London, S.W.1

Manufacturer FORD
Model CAPRI 3 LITRE
F.I.A. Recognition No. _____
Amendment No. 2

Amendment to Form of Recognition

FEDERATION INTERNATIONALE DE L'AUTOMOBILE

No.

Reference No.

GROUP II VARIANT

Equipment for Rear Disc Brake Conversion

Includes Caliper and mounting bracket, disc, and mounting collar.

Part No: CD 70/50

Increases rear track by 0.5ins.

100.	Outside Dia. of disc	5.25 inches
101.	Thickness of disc	.375 inches
102.	Length of brake lining	2.25 inches
103.	Width of brake lining	1.562 inches
104.	Number of pads per brake	2 (+2 for handbrake)
105.	Total area per brake	7 sq. ins. of pad 113 sq. ins. of disc

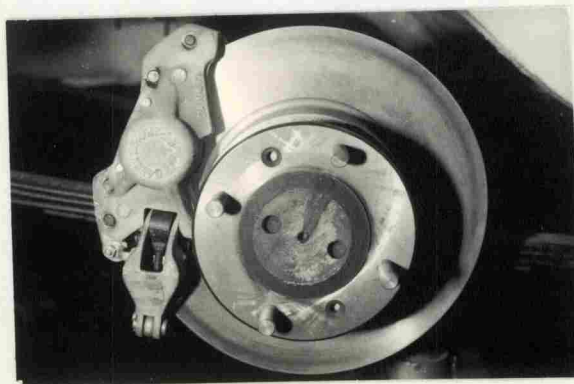

Date amendment is valid from.....



Stamp of F.I.A./R.A.C.



MOTOR SPORT DIVISION
The Royal Automobile Club,
31 Belgrave Square, London, S.W.1

Manufacturer FORD

Model CAPRI 3 LITRE

F.I.A. Recognition No. 5336

Amendment No. 2/25.GRII

Amendment to Form of Recognition

FEDERATION INTERNATIONALE DE L'AUTOMOBILE

No.

Reference No.

VARIANT GROUP II

Plastic Window Kit.

Part No. M69EB 215K43AA

Alternative Rear Axle assembly

Part No. CD 2930E 4011A

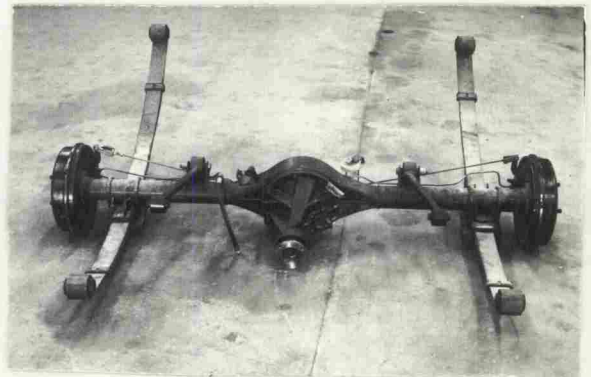

Date amendment is valid from 1/10/70 to 70/10

Stamp of F.I.A./R.A.C.



MOTOR SPORT DIVISION
The Royal Automobile Club,
31 Belgrave Square, London, S.W.1

Manufacturer FORD

Model CAPRI 3 LITRE

F.I.A. Recognition No. 5336

Amendment No. 3/35.GRII

Amendment to Form of Recognition

FEDERATION INTERNATIONALE DE L'AUTOMOBILE

No.

Reference No.

VARIANT GROUP II

Heavy duty rear axle shaft and bearing

Part No. CD 1000/206

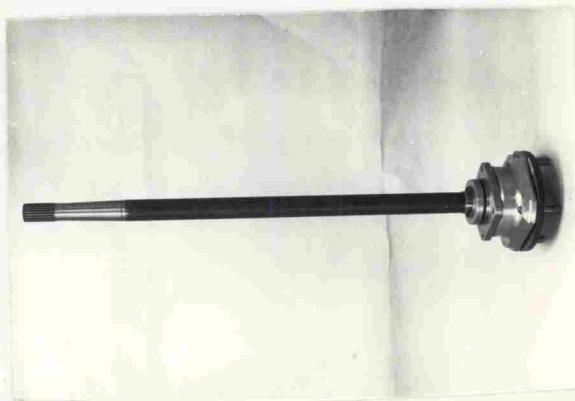

Rear Axle Oil pan

Part No. CD TD/83/02



Date amendment is valid from 1/10/70 to 70/10

Stamp of F.I.A./R.A.C.



MOTOR SPORT DIVISION
The Royal Automobile Club,
31 Belgrave Square, London, S.W.1

Manufacturer FORD
Model CAPRI 3 LITRE
F.I.A. Recognition No. 5336
Amendment No. 4/4 V - GRU

Amendment to Form of Recognition

FEDERATION INTERNATIONALE DE L'AUTOMOBILE

No.

Reference No.

NOTE

The 3 litre Capri basic model without KLP sales package weighs 18.1 cwts. 927.5 kg. 2040.5 lbs.

VARIANT GROUP II

Wheel arch extension kit Part No. GD 111F when fitted overall body width is increased by 5 cms. each side.



Date amendment is valid from 1/11/70

Stamp of F.I.A./R.A.C.



MOTOR SPORT DIVISION
The Royal Automobile Club,
31 Belgrave Square, London, S.W.1

Manufacturer FORD

Model Capri 3 litre

F.I.A. Recognition No. 5336

Amendment No. 5/5V-Gr II

Amendment to Form of Recognition

FEDERATION INTERNATIONALE DE L'AUTOMOBILE

No.

Reference No.

Variant Group II

Alternative Brakes of different type and dimensions including larger hubs and spindles.



Reinforced lower suspension arm. Part No. CD 26872



Date amendment is valid from 1/3/71 - List 71/3

Stamp of F.I.A./R.A.C.



MOTOR SPORT DIVISION
The Royal Automobile Club,
31 Belgrave Square, London, S.W.1

Manufacturer FORD
Model CAPRI 3 litre
F.I.A. Recognition No. 5336
Amendment No. 6/6V

Amendment to Form of Recognition

FEDERATION INTERNATIONALE DE L'AUTOMOBILE

No.

Reference No.

GROUP II VARIANT

Equipment for Dry Sump Lubrication, part number PG 0205



Date amendment is valid from.....

Stamp of F.I.A./R.A.C.



MOTOR SPORT DIVISION
The Royal Automobile Club,
31 Belgrave Square, London, S.W.1

Manufacturer..... Ford
Model..... Capri 3000
F.I.A. Recognition No. 5336
Amendment No. 7/1E

Amendment to Form of Recognition

FEDERATION INTERNATIONALE DE L'AUTOMOBILE

No.

Reference No.

EVOLUTION IN PRODUCTION

142	Compression ratio 9.52:1
182	Valve lift inlet 9.62m .375 in
197	Valve lift exhaust 8.84m .348 in
187	Valves open 29° BTDC
188	Valves close 67° ABDC
204	Diameter of outlet orifice 54m 2.125 in
215	Flange hole diameter 40m 1.57 in
216	Minimum diameter of choke 29m 1.14 in
292	Diff four pinion type
293	Final drive ratio 3.09:1 11/34 3.22:1 9/29

~~3.22:1 9/29~~

Date amendment is valid from.....

Stamp of F.I.A./R.A.C.



MOTOR SPORT DIVISION
The Royal Automobile Club,
31 Belgrave Square, London, S.W.1

Manufacturer Ford
Model Capri 3000
F.I.A. Recognition No. 5336
Amendment No. 8/2E

Amendment to Form of Recognition

FEDERATION INTERNATIONALE DE L'AUTOMOBILE

No.

Reference No.

EVOLUTION IN PRODUCTION

Drawing of inlet manifold parts (page 4).

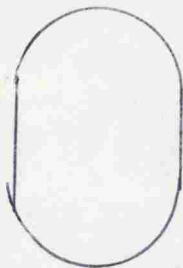

1.72 in

0.92 in

43.7 m

23.4 m



Drawing of exit to exhaust part of head (page 4).

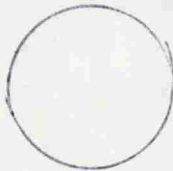

Δ/A 1.375 in

277	1	3.16	$\frac{21}{31} \times \frac{22}{23}$
	2	1.95	$\frac{21}{31} \times \frac{25}{19}$
	3	1.4	$\frac{21}{31} \times \frac{30}{14}$
	4	direct	
	R	3.35	34 x 15 x 17

Date amendment is valid from.....

Stamp of F.I.A./R.A.C.



MOTOR SPORT DIVISION
The Royal Automobile Club,
31 Belgrave Square, London, S.W.1

Manufacturer FORD
Model CAPRI 3000
F.I.A. Recognition No. 5336
Amendment No. 9/3E

Amendment to Form of Recognition

FEDERATION INTERNATIONALE DE L'AUTOMOBILE

No. | Reference No.

ERRATUM

- 157 Fan with clutch 7 blades
- 182 Max valve lift inlet 9.347 mm
- 187 Valves open 29° B T D C
- 188 Valves close 67° A B D C
- 197 Max valve lift exhaust 8.61 mm
- 204 Diameter outlet orifice 41.0 mm
- 213 Carb model ~~38~~/27 D G A S
- 215 Flange hole dia 38.0 mm
- 216 Venturi 27 mm

Drawing of inlet manifold ports

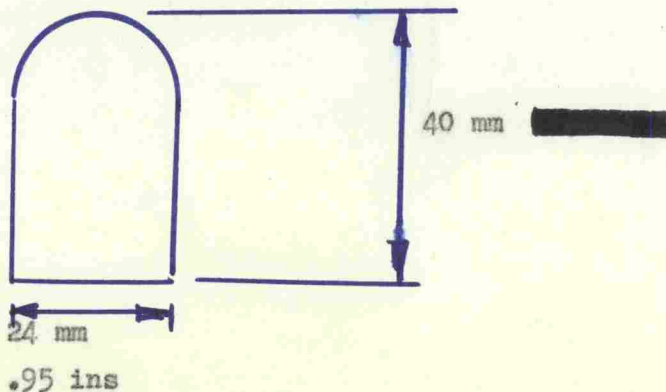

TOLERANCE $\pm 0.15 \text{ mm}$

Date amendment is valid from.....

Stamp of F.I.A./R.A.C.



MOTOR SPORT DIVISION
The Royal Automobile Club,
31 Belgrave Square, London, S.W.1

Manufacturer..... Ford
Model..... Capri.
F.I.A. Recognition No. 5336
Amendment No. 10/AE

Amendment to Form of Recognition

FEDERATION INTERNATIONALE DE L'AUTOMOBILE

No.

Reference No.

Evolution in Production

54 Rim Width 139.7mm 5.5ins.

51 Weight 5.94kg 13.1 lbs.

Export order specification suspension

Part number 69 EB 5560-C-A
69 EB 5560-D-A
3038E 5310 E
3038E 5310 F
69 EB 5310 AA
69 EB 5310 BA

Date amendment is valid from.....

Stamp of F.I.A./R.A.C.



MOTOR SPORT DIVISION
The Royal Automobile Club,
31 Belgrave Square, London, S.W.1

Manufacturer FORD
Model CAPRI 3 LITRE
F.I.A. Recognition No. 5336
Amendment No. 11/5E

Amendment to Form of Recognition

FEDERATION INTERNATIONALE DE L'AUTOMOBILE

No. | Reference No.

Production Evolution

Now fitted to all production models

Rear Suspension stabilizer.

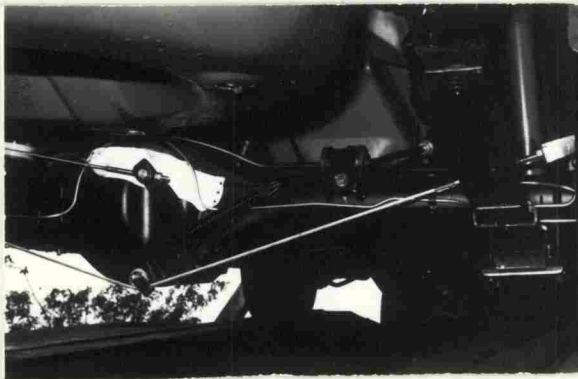

Date amendment is valid from.....

Stamp of F.I.A./R.A.C.



MOTOR SPORT DIVISION
The Royal Automobile Club,
31 Belgrave Square, London, S.W.1

Manufacturer..... FORD
Model..... CAPRI 3000
F.I.A. Recognition No. 5336
Amendment No. 12/6E

Amendment to Form of Recognition

FEDERATION INTERNATIONALE DE L'AUTOMOBILE

No.

Reference No.

Evolution in production

Revised body shape with dual headlight system on all cars from
January 1973 (See photograph A)

Revised instrument panel and dashboard on all cars from
January 1973 (See photograph B)

Date amendment is valid from..... 1.7.73

Stamp of F.I.A./R.A.C.



MOTOR SPORT DIVISION
The Royal Automobile Club,
31 Belgrave Square, London, S.W.1

Manufacturer FORD
Model CAPRI 3000
F.I.A. Recognition No. 5336
Amendment No.

Amendment to Form of Recognition

FEDERATION INTERNATIONALE DE L'AUTOMOBILE

Photographs must be 3"×2" and a matt finish



Photograph A



Photograph B

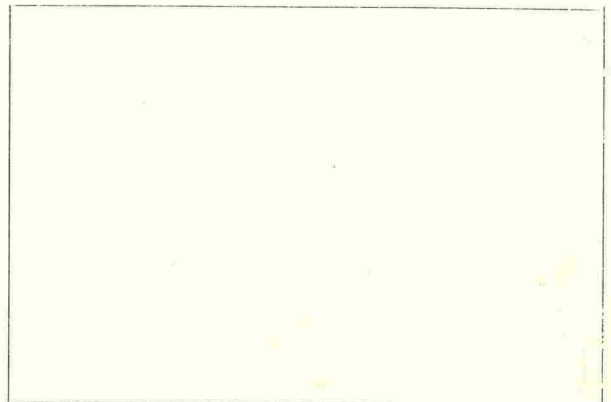
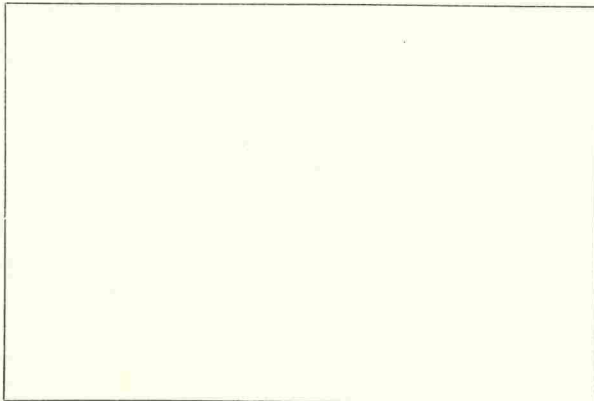
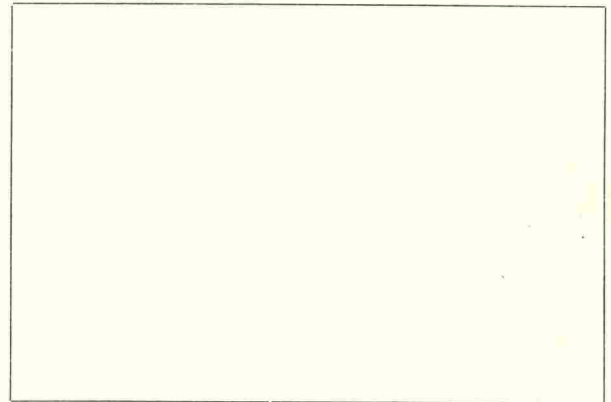
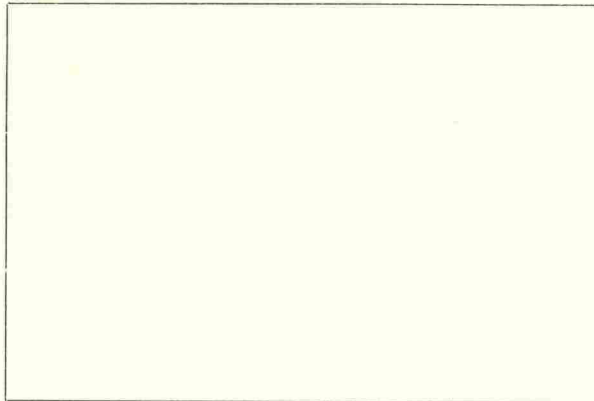

Date amendment is valid from.....

Stamp of F.I.A./R.A.C.



MOTOR SPORT DIVISION
The Royal Automobile Club,
31 Belgrave Square, London, S.W.1

Manufacturer FORD
Model CAPRI
F.I.A. Recognition No. 5336
Amendment No. 13/7V

Amendment to Form of Recognition

FEDERATION INTERNATIONALE DE L'AUTOMOBILE

No.	Reference No.
	GROUP 2 VARIANT
	Oil cooler kit for gearbox Part No. 9050990 (Photo A)
	Oil cooler kit for rear axle Part No. 9050990 (Photo A)

"valable en Groupe 2 uniquement"
"valid for Group 2 only"

Date amendment is valid from... 1.10.73 ...

Stamp of F.I.A./R.A.C.



MOTOR SPORT DIVISION
The Royal Automobile Club
31 Belgrave Square, London SW1X 8QH

Manufacturer FORD
Model CAPRI
F.I.A. Recognition No. 5336
Amendment No.

Amendment to Form of Recognition

FEDERATION INTERNATIONALE DE L'AUTOMOBILE

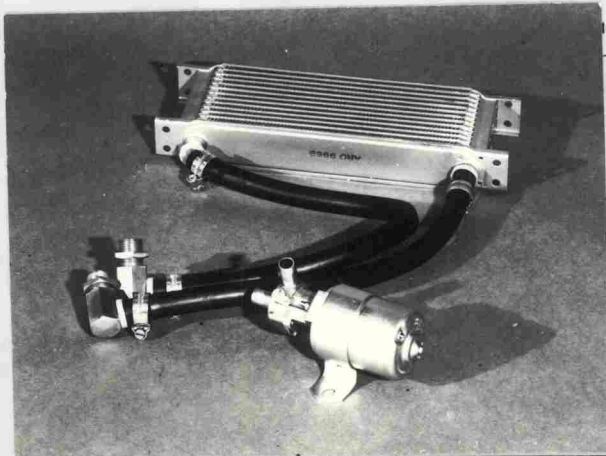

Photo A

..... must be 3" x 2" and a matt finish

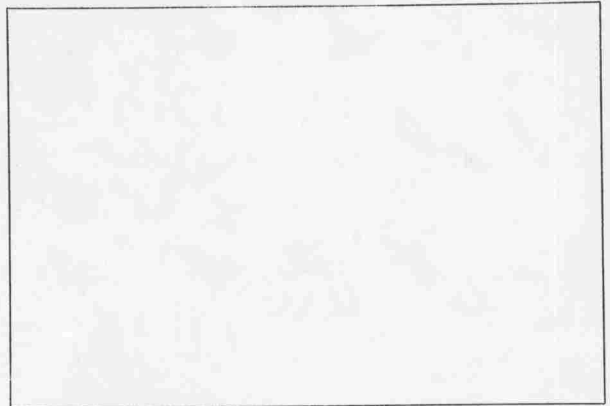
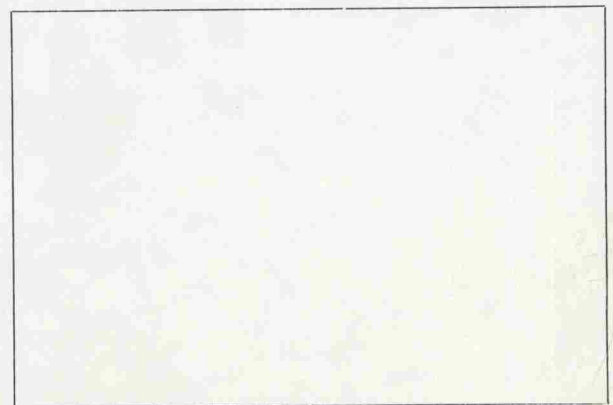
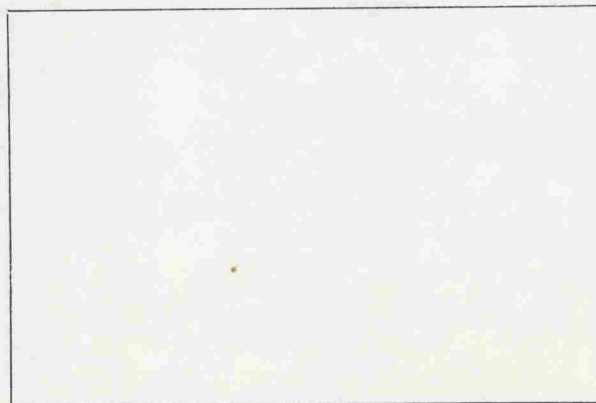
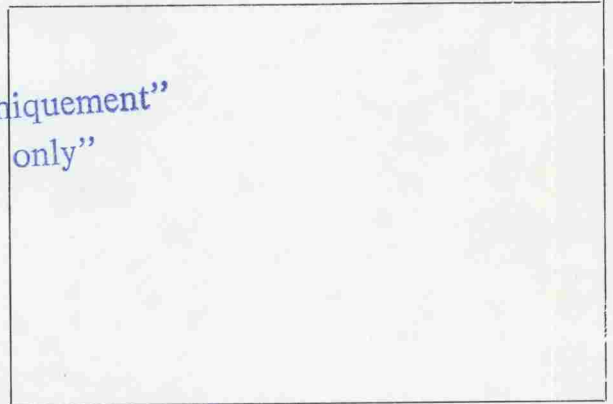
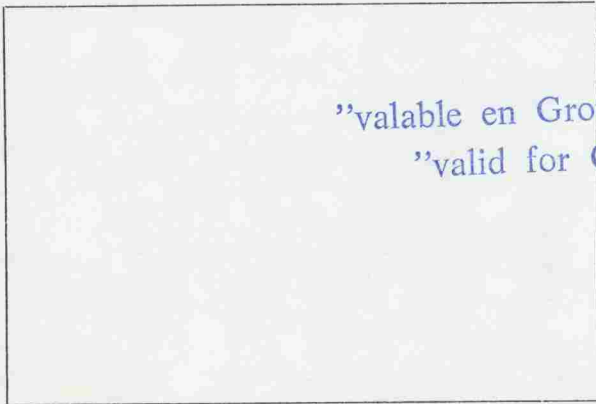

Photo B

"valable en Groupe 2 uniquement"
"valid for Group 2 only"



Date amendment is valid from.....

Stamp of F.I.A./R.A.C.



MOTOR SPORT DIVISION
The Royal Automobile Club
31 Belgrave Square, London SW1X 8QH

Manufacturer **FORD**
 Model **CAPRI**
 F.I.A. Recognition No. **5336**
 Amendment No. **4/8V**

Amendment to Form of Recognition

FEDERATION INTERNATIONALE DE L'AUTOMOBILE

No. Reference No.

GROUP 2 VARIANT

Reinforced front fender apron (left and right side)

part nos. 3038E 16136 A

3038E 16137 A

Photo C

Reinforced front suspension stiffener (left and right side)

part nos. 3038E 16K099 A

3038E 16K100 A

Reinforced upper front suspension (left and right side)

part nos. 3038E 70 110K40 A

3038E 70 110K41 A

Photo B

Apron front fender Right part no. 72 EG 160 44 BA

Left part no. 72 EG 160 45 BA

Photo A

"valable en Groupe 2 uniquement"
"valid for Group 2 only"

Date amendment is valid from **1.10.73**

Stamp of F.I.A./R.A.C.



MOTOR SPORT DIVISION
The Royal Automobile Club
31 Belgrave Square, London SW1X 8QH

Manufacturer FORD
Model CAPRI
F.I.A. Recognition No. 5336
Amendment No. _____

Amendment to Form of Recognition

FEDERATION INTERNATIONALE DE L'AUTOMOBILE

Photographs must be 3" x 2" and a matt finish

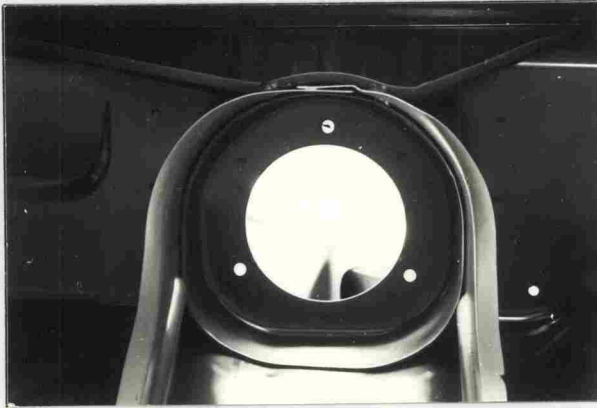

Photo A

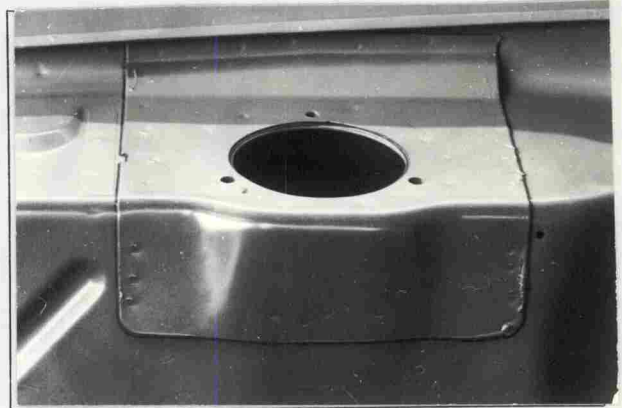
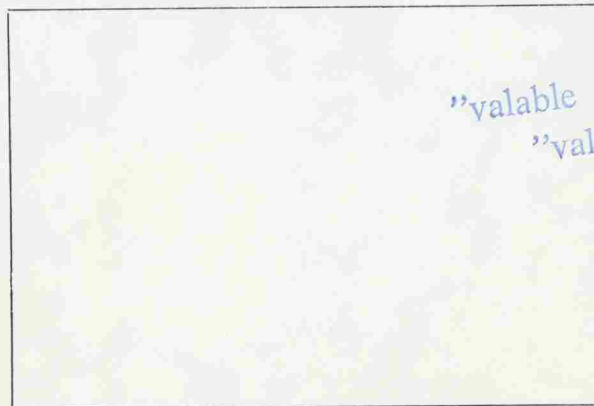
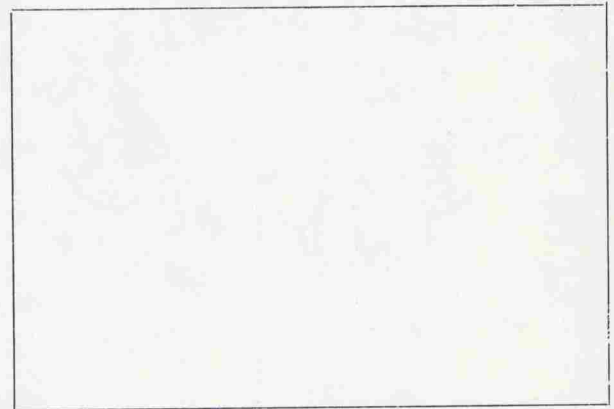

Photo B



Photo C



"valable en Groupe 2 uniquement"
"valid for Group 2 only"

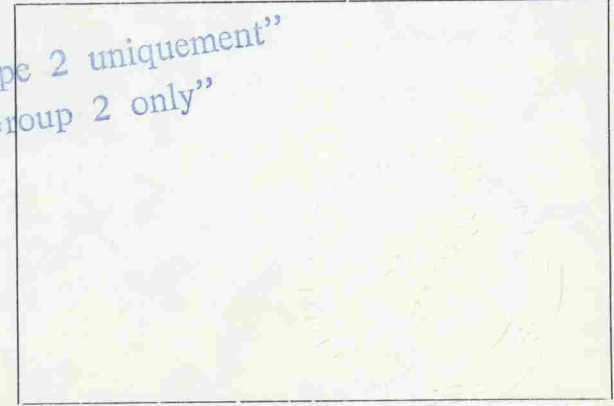

Date amendment is valid from.....

Stamp of F.I.A./R.A.C.



MOTOR SPORT DIVISION
The Royal Automobile Club,
31 Belgrave Square, London, S.W.1

Manufacturer FORD
Model CAPRI
F.I.A. Recognition No. 5336
Amendment No. 15/9V

Amendment to Form of Recognition

FEDERATION INTERNATIONALE DE L'AUTOMOBILE

No.	Reference No.
	GROUP 2 VARIANT
	Triple-plate clutch (Photo A) Part No. 9052312
161	10.3 kilograms 22.6 lb
261	3
262	184.5 mm 7.3 ins
263	inner 134 mm 5.3 ins
	outer 184.5 mm 7.3 ins
	Brake power control valve
	Part No. 0860128
	Alternative supplier
	Rear axle cover in light metal with mounting for Watts link (locating arm) Part No. 529051682 (Photo B)

"valable en Groupe 2 uniquement"
"valid for Group 2 only"

Date amendment is valid from 1.10.73

Stamp of F.I.A./R.A.C.



MOTOR SPORT DIVISION
The Royal Automobile Club
31 Belgrave Square, London SW1X 8QH

Manufacturer FORD
 Model CAPRI
 F.I.A. Recognition No. 5336
 Amendment No. _____

Amendment to Form of Recognition

FEDERATION INTERNATIONALE DE L'AUTOMOBILE

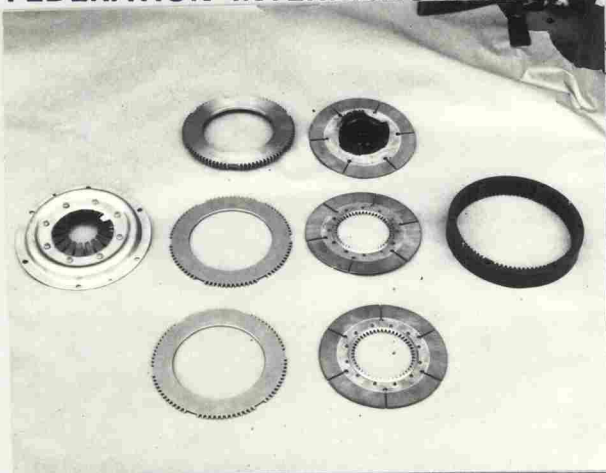

Photo A

st be 3" x 2"



Photo B

"valable en Groupe 2 uniquement"
 "valid for Group 2 only"

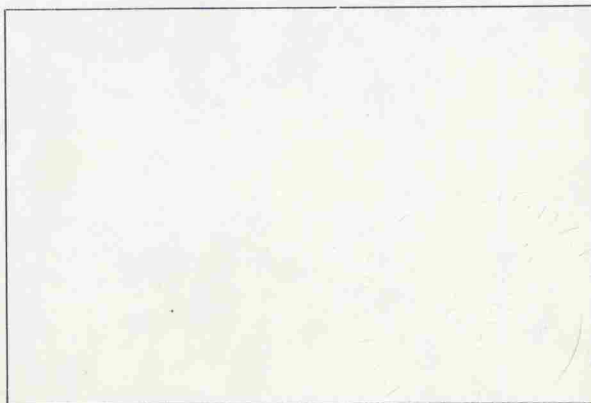
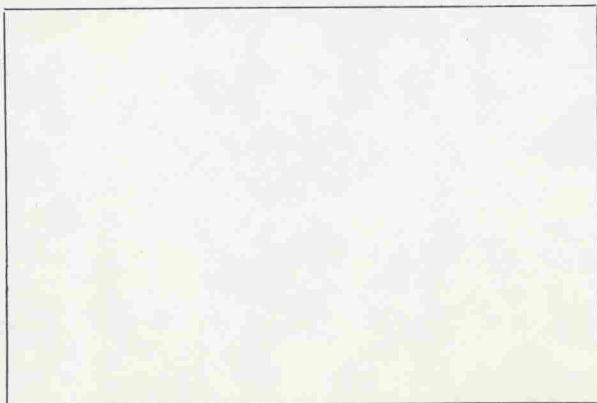
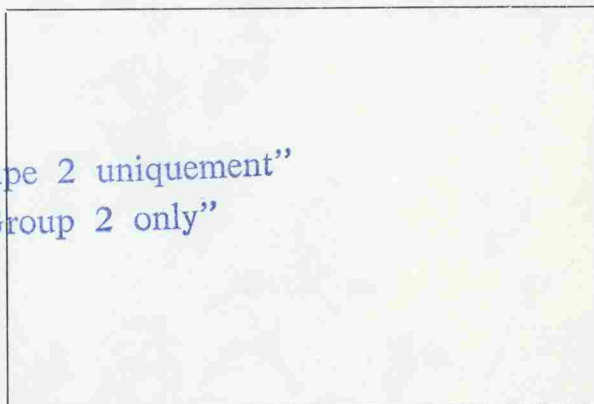
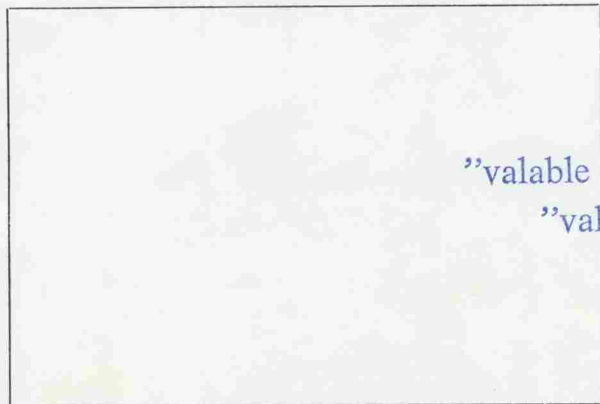

Date amendment is valid from.....

Stamp of F.I.A./R.A.C.



MOTOR SPORT DIVISION
The Royal Automobile Club,
31 Belgrave Square, London, S.W.1

Manufacturer FORD
Model CAPRI
F.I.A. Recognition No. 5336
Amendment No. 16/10V

Amendment to Form of Recognition

FEDERATION INTERNATIONALE DE L'AUTOMOBILE

No.	Reference No.
	GROUP 2 VARIANT
	Different dashboard (photo A)
	Wing extensions increasing the width of the wings by not more than 5 cms (photos B, C and D) Part Nos. 9050971/2/3/4
	Heavy duty windshield wiper equipment (left and right hand) Photo E
	Sump shield (photo F)

"valable en Groupe 2 uniquement"
"valid for Group 2 only"

Date amendment is valid from... 1.10.73

Stamp of F.I.A./R.A.C.



MOTOR SPORT DIVISION
The Royal Automobile Club
31 Belgrave Square, London SW1X 8QH

Manufacturer **FORD**
 Model **CAPRI**
 F.I.A. Recognition No. **5336**
 Amendment No.

Amendment to Form of Recognition

FEDERATION INTERNATIONALE DE L'AUTOMOBILE

Photographs must be 3" x 2" and a matt finish

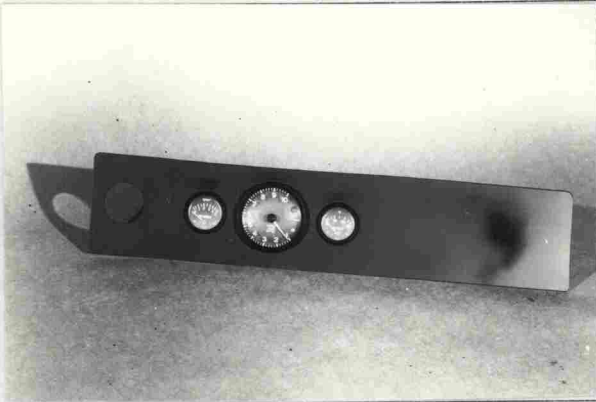

Photo A

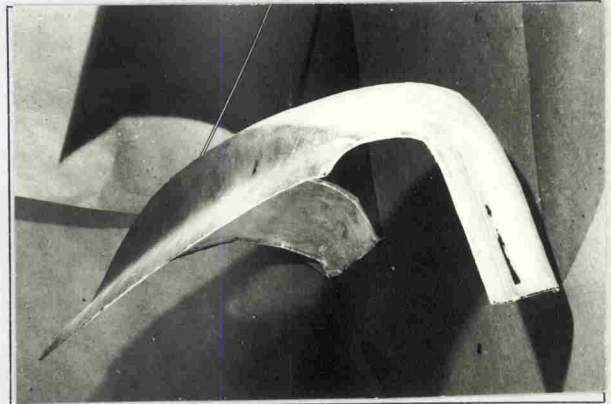

Photo B

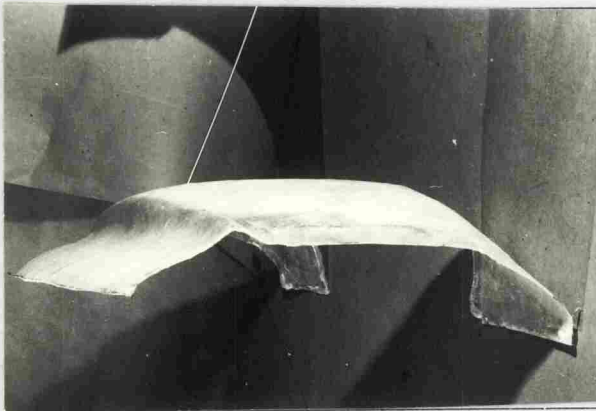

Photo C



Photo D



Photo E



Photo F

Date amendment is valid from.....

"valable en Groupe 2 uniquement"
"valid for Group 2 only"

Stamp of F.I.A./R.A.C.



MOTOR SPORT DIVISION
The Royal Automobile Club
31 Belgrave Square, London SW1X 8QH

Manufacturer FORD
 Model CAPRI
 F.I.A. Recognition No. 5336
 Amendment No. 17/7E

Amendment to Form of Recognition

FEDERATION INTERNATIONALE DE L'AUTOMOBILE

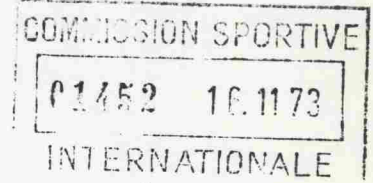

No.	Reference No.
ERRATUM	
Cooling fan with clutch	
156	38.1 cm 15.0 ins
157	No. of blades of cooling fan 8

Date amendment is valid from 1.1.76

 Stamp of F.I.A./R.A.C.



MOTOR SPORT DIVISION
The Royal Automobile Club
31 Belgrave Square, London SW1X 8QH

Manufacturer FORD
 Model CAPRI
 F.I.A. Recognition No. 5336
 Amendment No. 18/11V

Amendment to Form of Recognition

FEDERATION INTERNATIONALE DE L'AUTOMOBILE



No.	Reference No.
	<i>"valable en Groupe 2 uniquement"</i> <i>"valid for Group 2 only"</i>
	VARIANT
	Sump shield Photo A
	Part No. 90 50 200
	Weight 11.2 kg 24.7 lb
	Dimensions: 780 mm (30.7 ins) x 660 mm (26.0 ins) x 125 mm (4.9 ins)
	Rear axle fitted in German production (alternative supplier) Photo B
	Part No. 90 50 438 with ZF limited slip
	Final drive ratio 3.09 : 1 Number of teeth 11/34

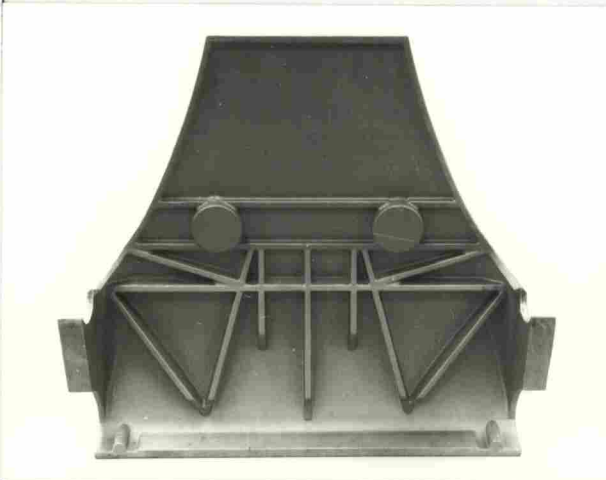

Photo A



Photo B

Date amendment is valid from 1.1.76

Stamp of F.I.A./R.A.C.



MOTOR SPORT DIVISION
The Royal Automobile Club
31 Belgrave Square, London SW1X 8QH

Manufacturer FORD.....

COMMISSION SPORTIVE Model CAPRI.....
 F.I.A. Recognition No. 5336
 Amendment No. 19/8E
 00424 18.2.74
 INTERNATIONALE

Amendment to Form of Recognition

FEDERATION INTERNATIONALE DE L'AUTOMOBILE

No.	Reference No.		
	Camshaft - evolution in production from 1 January 1974		
	Part No. 722M 6250 AA		
182	0.2836 ins	7.203 mm	
186	0.002 ins	0.05 mm	
187	74° B T D C		
188	128° A B D C		
197	0.2691 ins	6.835 mm	
201	0.002 ins	0.05 mm	
202	140° B B D C		
203	115° A T D C		
a55	Inlet	S = 0.8256 - 0.829 ins	20.97 - 21.05 mm
		T = 0.542 - 0.545 ins	13.76 - 13.84 mm
		U = 1.102 - 1.108 ins	27.99 - 28.02 mm
	Exhaust	S = 0.8111 - 0.8141 ins	20.59 - 20.78 mm
		T = 0.542 - 0.545 ins	13.76 - 13.84 mm
		U = 1.096 - 1.102 ins	27.83 - 27.99 mm

Date amendment is valid from 1.6.74

Stamp of F.I.A./R.A.C.



MOTOR SPORT DIVISION
The Royal Automobile Club
31 Belgrave Square, London SW1X 8QH

Manufacturer FORD

Model CAPRI

F.I.A. Recognition No. 5336

Amendment No. 20/9E



Amendment to Form of Recognition

FEDERATION INTERNATIONALE DE L'AUTOMOBILE

No.

Reference No.

Evolution in production

Revised body shell with third door

See Photos A B and C and D

1	2559 mm	100.7 ins	
2	Front track	135.7 cms	53.5 ins
3	Rear track	139.2 cms	55.0 ins
4	430.0 cm	168.8 ins	
5	Overall width	169.8 cms	66.9 ins
6	129.9 cm	53.4 ins	
10	Front	167.0 cm	65.75 ins
	Rear	177 cm	67.25 ins

53 5.5 Steel 6.0 Alloy

293 Alternative final drive 3.44 31/9

4 Dia. Exhaust Port in Head 1.45" Dia. \pm .1"
 36.8mm \pm 2.5 mm

7 78 litres 17.1 gallons

Date amendment is valid from 1.7.74

Stamp of F.I.A./R.A.C.



MOTOR SPORT DIVISION
The Royal Automobile Club
31 Belgrave Square, London SW1X 8QH

Manufacturer FORD.....
 Model CAPRI.....
 F.I.A. Recognition No. 5336

COMMISSION SPORTIVE
 01020 13.5.74
 INTERNATIONALE

Amendment No.

Amendment to Form of Recognition

FEDERATION INTERNATIONALE DE L'AUTOMOBILE

Photographs must be 3" x 2" and a matt finish



Photograph A



Photograph B



Photograph C



Photograph D

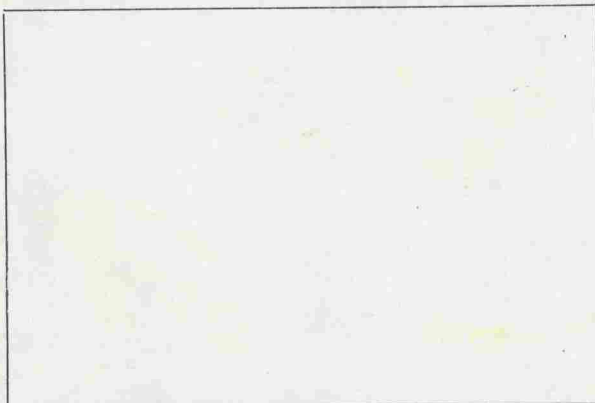

Photograph E

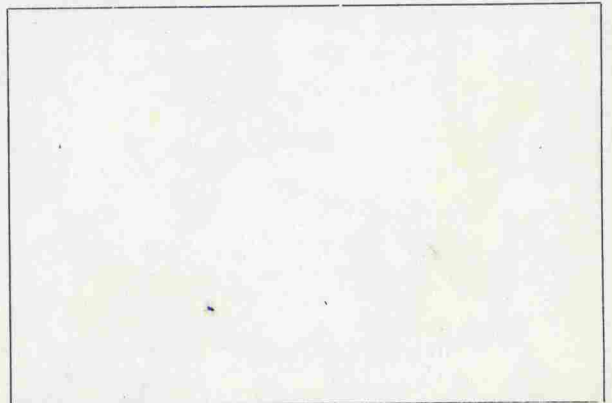

Photograph F

Date amendment is valid from.....

Stamp of F.I.A./R.A.C.



MOTOR SPORT DIVISION
The Royal Automobile Club
31 Belgrave Square, London SW1X 8QH

Manufacturer FORD

Model CAPRI

F.I.A. Recognition No. 5336

Amendment No.



Amendment to Form of Recognition

FEDERATION INTERNATIONALE DE L'AUTOMOBILE

VALID IN GROUP.....

No.

Reference No.

Evolution in production

Modifications to gear change

Photograph E

Latest level engine compartment

Photograph F



MOTOR SPORT DIVISION
The Royal Automobile Club
 31 Belgrave Square, London SW1X 8QH

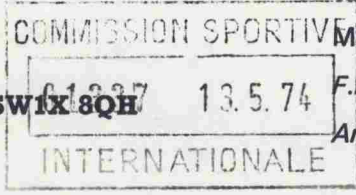

Manufacturer FORD
 Model CAPRI
 F.I.A. Recognition No. 5336
 Amendment No. 21 / 10E

Amendment to Form of Recognition

FEDERATION INTERNATIONALE DE L'AUTOMOBILE

VALID IN GROUP

No.	Reference No.
	<u>Errata</u>
a55	Dimension T can be reduced by .020" (.5 mm) or .040" (1.00 mm) as factory reclaim.



Date amendment is valid from..... 1.7.76

[Handwritten signature]
 Stamp of F.I.A./R.A.C.



MOTOR SPORT DIVISION
The Royal Automobile Club
31 Belgrave Square, London SW1X 8QH

Manufacturer FORD
 Model CAPRI 3 LITRE
 F.I.A. Recognition No. 5336
 Amendment No. 82/12V

Amendment to Form of Recognition

FEDERATION INTERNATIONALE DE L'AUTOMOBILE
VALID IN GROUP.....



No.	Reference No.		
		Production Variant on Emission Control Cars	
181	44.5 mm	1.75 ins	
182	11.1 mm	0.4375 ins	
196	41.1 mm	1.61 ins	
197	11.1 mm	0.4375 ins	
a55	S = 20.9 mm	0.824 ins	
	T = 12.7 mm	0.50 ins	
	U = 25.7 mm	1.012 ins	



Date amendment is valid from..... 1.7.76

[Signature]
 Stamp of F.I.A./R.A.C.



MOTOR SPORT DIVISION
The Royal Automobile Club
31 Belgrave Square, London SW1X 8QH

Manufacturer FORD
 Model CAPRI
 F.I.A. Recognition No. 5336
 Amendment No. 23/11 E

Amendment to Form of Recognition

FEDERATION INTERNATIONALE DE L'AUTOMOBILE

No. Reference No.

ERRATA

Dimensions of port in cylinder head

Inlet

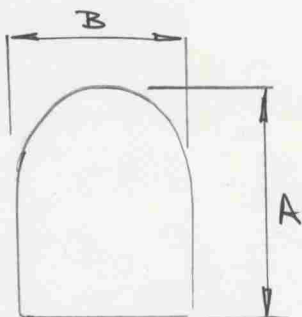

A = 1.75 ins 44.5 mm

B = 1.08 ins 27.4 mm

2	Front track	1385.0 mm	± 25.4 mm	54.5 ins	± 1.0 ins
3	Rear track	1360.0 mm	± 25.4 mm	53.5 ins	± 1.0 ins
160	8.64 kg	19 lb			
	Tolerance		+ 1.35 lb	0.62 kg	
			- 0.6 lb	0.27 kg	
161	16.1 kg	35.5 lb			
			+ 1.13 kg	2.5 lb	
			- 0.5 kg	1.17 lb	tolerance
162	17.7 kg	39 lb			
	Tolerance		+ 1.24 kg	2.73 lb	
			- 0.59 kg	1.3 lb	
163	0.7 kg	1.54 lbs			
	Tolerance		+ 0.11 lb	0.05 kg	
			- 0.05 lb	0.02 kg	



Date amendment is valid from 1.8.76

Stamp of F.I.A./R.A.C.



MOTOR SPORT DIVISION
The Royal Automobile Club
31 Belgrave Square, London SW1X 8QH

Manufacturer FORD

Model CAPRI

F.I.A. Recognition No. 5336

Amendment No. 24/12 E

Amendment to Form of Recognition

FEDERATION INTERNATIONALE DE L'AUTOMOBILE

VALID IN GROUP 1

No.	Reference No.	<u>ERRATA</u>	
	Page 19/8E		
	182	9.626 mm	(.379")
	197	9.068 mm	(.357")
	Page 20/9E		
	10 Rear	170 mm	(67.25")
	6	129.9 mm	(51.1")
	Page 22/12V		
	196	40.8 mm	(1.61")



Date amendment is valid from... 1 10 74

Stamp of F.I.A./R.A.C.



MOTOR SPORT DIVISION
The Royal Automobile Club
31 Belgrave Square, London SW1X 8QH

Manufacturer FORD
 Model CAPRI 3-LITRE
 F.I.A. Recognition No. 5336
 Amendment No. 25/13 ✓

Amendment to Form of Recognition

FEDERATION INTERNATIONALE DE L'AUTOMOBILE

VALID IN GROUP.....¹.....

No.	Reference No.
	PRODUCTION VARIANT
	Used in conjunction with Exhaust emission parts for certain specified countries
210	One
213	40 DFI 5 [REDACTED]
215	40mm. 1.575in.
216	32mm 1.260in.



Date amendment is valid from 1.2.75

Stamp of F.I.A./R.A.C.



MOTOR SPORT DIVISION
The Royal Automobile Club
31 Belgrave Square, London SW1X 8QH

Manufacturer FORD
 Model CAPRI
 F.I.A. Recognition No. 5336
 Amendment No. 26/14.V

Amendment to Form of Recognition

FEDERATION INTERNATIONALE DE L'AUTOMOBILE
VALID IN GROUP1.....

No.	Reference No.
	Reference Amendment <u>20/9E</u>
53	5.5" Alloy wheel as shown in Photograph A
	6.0" Alloy wheel as shown in Photograph B



B



Date amendment is valid from 1.1.75

Stamp of F.I.A./R.A.C.



MOTOR SPORT DIVISION
The Royal Automobile Club
31 Belgrave Square, London SW1X 8QH

Manufacturer FORD
 Model CAPRI 3 Litre
 F.I.A. Recognition No. 5336
 Amendment No. 27/15V

Amendment to Form of Recognition

FEDERATION INTERNATIONALE DE L'AUTOMOBILE

VALID IN GROUP2.....

No.

Reference No.

~~Heavy duty rear axle incorporating optional disc brake and optional heavy duty wheel bearings and hub assembly - see photo C.~~

~~Maximum dia disc = 266.7 mm 10.5 in
 Disc thickness = 12.7 mm 0.5 in Part No: CP 2407
 Part No: CP 2407 126~~

~~Photo B~~

~~Ventilated disc option for same axle - Part No: CP 2261-39~~

~~Dia = 266.7 mm 10.5 in
 Max thickness = 20.5 mm 0.810in~~

Reinforced suspension element - heavy duty front hub - alum. alloy
 Part No: H69AB 1104 AA - see photo D.

Ventilated Front disc assembly.
 Part No: CP2261-39 - see photo D.

Maximum disc dia = 266.7 mm 10.5 in
 Maximum disc thickness = 25.4 mm 1.0 in

Caliper - 4 piston - Photo D.
 Part No: CP2260

No of pads/brakes = 2
 Length of pad = 115 mm 4.55 in

Final drive ratio's. (Axle ratio) available for production axle.

3.09	3.75	4.375	5.1
3.22	3.89	4.6	5.3
3.44	4.11	4.89	

Optional extra. Safety fuel tank complying with F.I.A. regulations.

Date amendment is valid from 1.1.76

Stamp of F.I.A./R.A.C.





MOTOR SPORT DIVISION
The Royal Automobile Club
31 Belgrave Square, London SW1X 8QH

Manufacturer FORD
 Model CAPRI 3 litre
 F.I.A. Recognition No. 5336
 Amendment No. _____

Amendment to Form of Recognition

FEDERATION INTERNATIONALE DE L'AUTOMOBILE

Photographs must be 3" x 2" and a matt finish

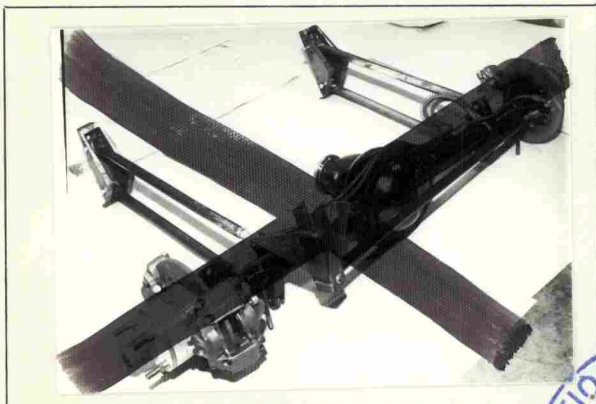

C

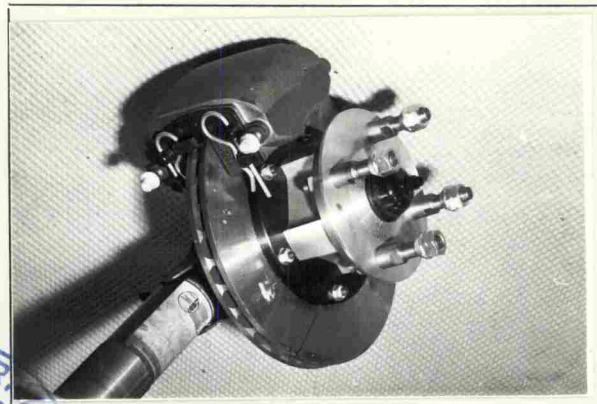

D

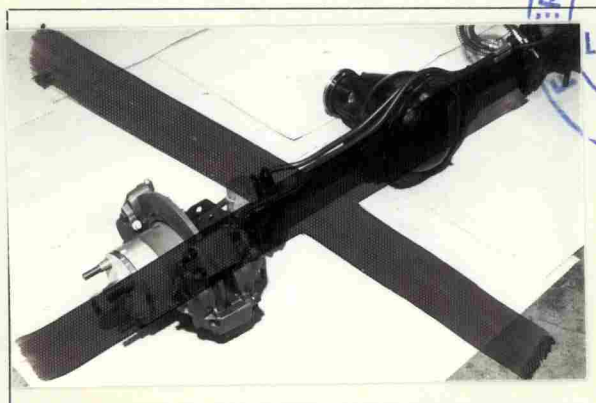

E

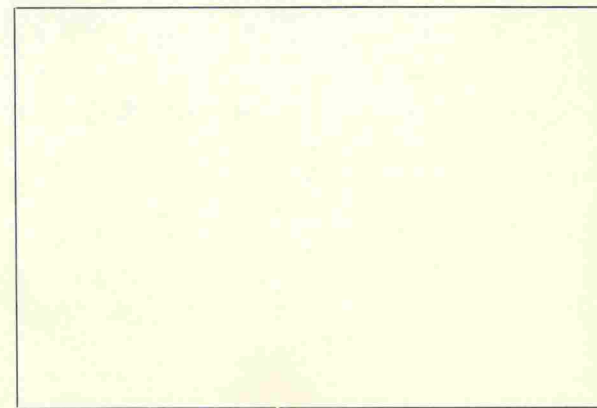
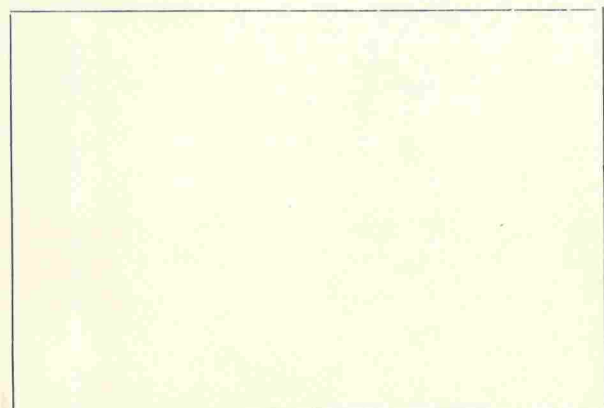

Date amendment is valid from 1.1.76

Stamp of F.I.A./R.A.C.



MOTOR SPORT DIVISION
The Royal Automobile Club
31 Belgrave Square, London SW1X 8QH

Manufacturer **FORD**
 Model **CAPRI 3 Litre**
 F.I.A. Recognition No. **5336**
 Amendment No. **28/16V**

Amendment to Form of Recognition

FEDERATION INTERNATIONALE DE L'AUTOMOBILE

VALID IN GROUP.....1.....

No.

Reference No.

Optional parts available for cars exported to specific export territories.

Ventilated front disc and associated calipers and hubs. Photo A.

Part Nos:
 H74EB 1102AA
 73GB 2010GA
 73GB 2011GA
 H73EB 2K005AA
 H73EB 2K004AA
 3024E 1216A
 72GB 1216AA
 72GB 1201AA

Maximum disc dia = 266.7 mm 10.5 in
Disc thickness = 20 mm 0.78 in

Alternative supplier of bellhousing - material alum. alloy.
Part No: H72EB 7505EA. Photo B.

Alternative gear ratio's available for existing gearbox casing:

1st5	2.42
2nd	1.67
3rd	1.24
Top	1.0



[REDACTED]

[REDACTED]

[REDACTED]

[REDACTED]



Date amendment is valid from 1.1.76

Stamp of F.I.A./R.A.C.



MOTOR SPORT DIVISION
The Royal Automobile Club
31 Belgrave Square, London SW1X 8QH

Manufacturer **FORD**
 Model **CAPRI 3 litre**
 F.I.A. Recognition No. **5336**
 Amendment No.

Amendment to Form of Recognition

FEDERATION INTERNATIONALE DE L'AUTOMOBILE

Photographs must be 3" x 2" and a matt finish

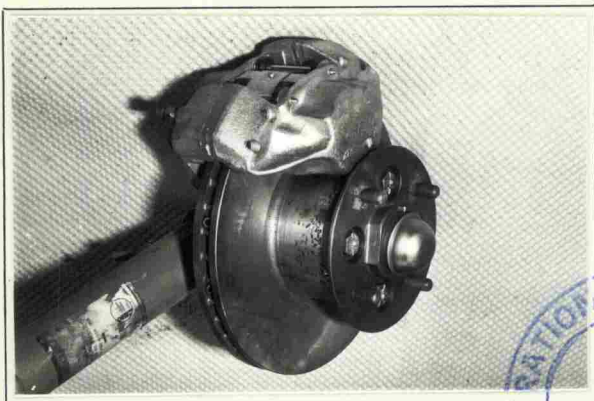

A

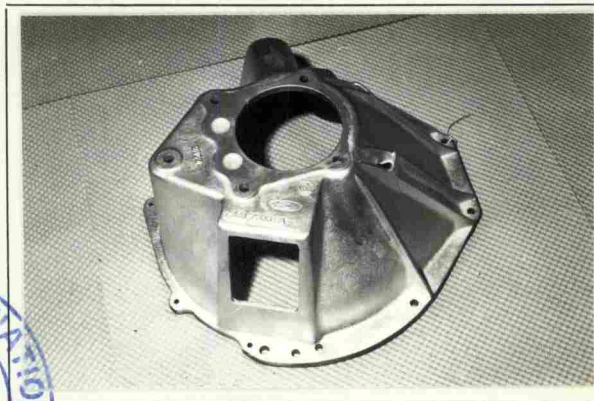

B

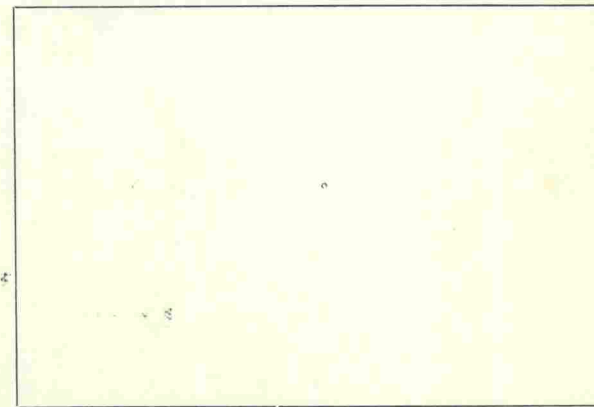
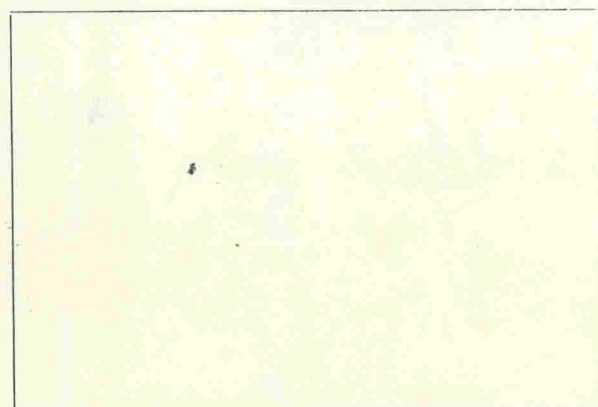
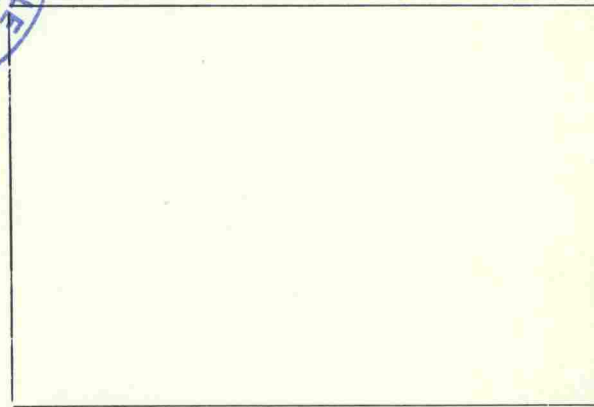
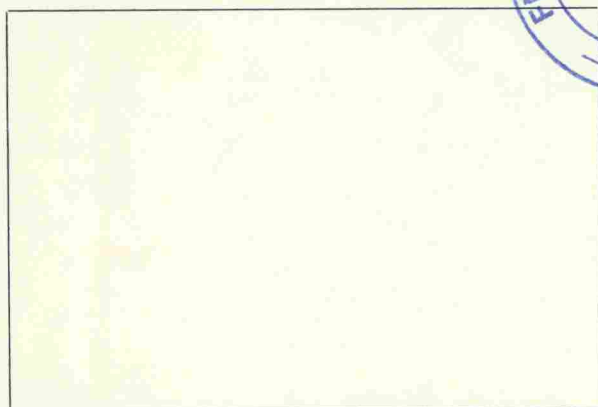

Date amendment is valid from 1.7.76

Stamp of F.I.A./R.A.C.

29/17V

FÉDÉRATION INTERNATIONALE DE L'AUTOMOBILE

FICHE D'EXTENSION D'HOMOLOGATION
CONFORME A L'ANNEXE J DU CODE SPORTIF INTERNATIONAL

Marque **FORD** Modèle **CAPRI 3 Litres**

Numéros de série inaugurant les modifications décrites : Chassis/Carrosserie
Moteur

Date de sortie des premiers véhicules construits avec les modifications : 19

Dénomination commerciale après application des modifications :

Cette extension d'homologation doit être considérée comme : variante - évolution normale du type.

L'homologation est valable du 1 3 19 76 Liste

Descriptions des modifications :

HIGHER PERFORMANCE ENGINE (high altitude territories)

=====

142	10.25 ± 0.5	
143	53.94 cc	3.29 cub. in.
216	34 mm	(for DF15 carburettor).

Signature et cachet
de l'Autorité Sportive Nationale :





MOTOR SPORT DIVISION
The Royal Automobile Club
31 Belgrave Square, London SW1X 8QH

Manufacturer FORD
Model CAPRI 3 Litre
F.I.A. Recognition No. 5336
Amendment No. 30/18V

Amendment to Form of Recognition

FEDERATION INTERNATIONALE DE L'AUTOMOBILE

VALID IN GROUP¹.....

No.	Reference No.
	<u>Optional Equipment</u>
153	Oil cooler kit See photo E76
152	Increases capacity by 1.4 litres
293	3.75

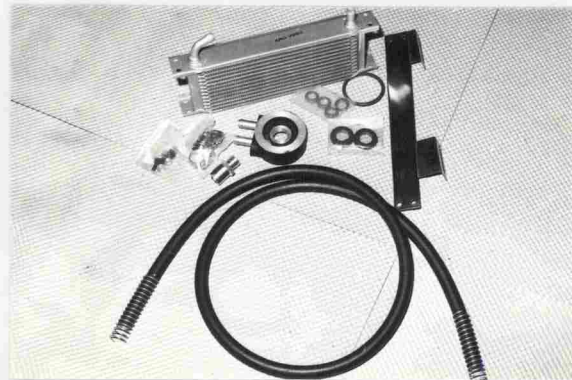

Date amendment is valid from 1.6.76

Stamp of F.I.A./R.A.C.



MOTOR SPORT DIVISION
The Royal Automobile Club
31 Belgrave Square, London SW1X 8QH

Manufacturer FORD
 Model CAPRI 3 Litre
 F.I.A. Recognition No. 5336
 Amendment No. 31/14V

Amendment to Form of Recognition

FEDERATION INTERNATIONALE DE L'AUTOMOBILE

No. | Reference No.

Optional Equipment

Sports driving seat

Part No's: 9053198 L/H
 9053199 R/H

Weight: 14.8 Kg

(SCHEELE MANUFACTURE)



Date amendment is valid from 1.4.76

Stamp of F.I.A./R.A.C.



MOTOR SPORT DIVISION
The Royal Automobile Club
31 Belgrave Square, London SW1X 8QH

Manufacturer FORD
 Model CAPRI 3 Litre
 F.I.A. Recognition No. 5336
 Amendment No. 32/13E

Amendment to Form of Recognition

FEDERATION INTERNATIONALE DE L'AUTOMOBILE

VALID IN GROUP¹

No. Reference No.

Evolution

Ref Amendment 14/8V

Reinforced front fender apron - top and bottom

Reinforced suspension stiffener

Are now standard production on all 3 litre Capri cars.

Minor styling change to road wheel track increase
 as before 12 mm. See photo.



Date amendment is valid from... 1.4.76

Stamp of F.I.A./R.A.C.



MOTOR SPORT DIVISION
The Royal Automobile Club
31 Belgrave Square, London SW1X 8QH

Manufacturer FORD
 Model CAPRI 3 Litre
 F.I.A. Recognition No. 5336
 Amendment No. 33 / 14E

Amendment to Form of Recognition

FEDERATION INTERNATIONALE DE L'AUTOMOBILE

No. | Reference No.

Errata

Ref 28/16V

Disc Dia = 244 mm

Thickness = 24 mm

Revised part no's for disc assembly:

9052592		Hub/Disc
1511967	or 6015124	Caliper
1511969	or 6015126	Caliper
9052016		Shield
9052017		Shield
9052013		Strut
9052014		Strut
9052601		Brake Line
9052602		Brake Line



Date amendment is valid from 1.6.76

Stamp of F.I.A./R.A.C.



MOTOR SPORT DIVISION
The Royal Automobile Club
31 Belgrave Square, London SW1X 8QH

Manufacturer FORD
 Model CAPRI 3 Litre
 F.I.A. Recognition No. 5336
 Amendment No. 36/20V

Amendment to Form of Recognition

FEDERATION INTERNATIONALE DE L'AUTOMOBILE

VALID IN GROUP 1

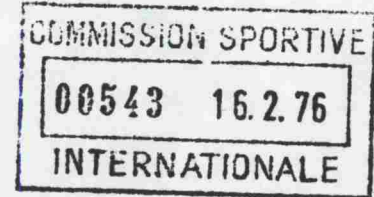

No.	Reference No.
	Variant
	Capri S
	Optional trim level model, mechanically similar to existing homologated car with following exceptions:
41	Reclining seat with head restraint
42	14.8 Kg See photo A76
50	Cast light alloy
51	5.2 Kg
52	4, Sleeve nut
53	330 mm (13 in)
54	140 mm (5.5 in) See photo B76
	Sport style steering wheel
	See photo C76
	Revised paint scheme
	See photo D76



Date amendment is valid from 1 4 76

Stamp of F.I.A./R.A.C.



MOTOR SPORT DIVISION
The Royal Automobile Club
31 Belgrave Square, London SW1X 8QH

Manufacturer **FORD**
 Model **CAPRI 3 Litre**
 F.I.A. Recognition No. **5336**
 Amendment No. **35/21 V**

Amendment to Form of Recognition

FEDERATION INTERNATIONALE DE L'AUTOMOBILE

VALID IN GROUP.....1.....

No.	Reference No.
	Optional Equipment
62	Steering ratio, lock to lock 2,44
	Reinforced suspension mounting point for specified export territories
	See photo D 76



D 76

-1.OCT.19/6



Date amendment is valid from.....

Stamp of F.I.A./R.A.C.



MOTOR SPORT DIVISION
The Royal Automobile Club
31 Belgrave Square, London SW1X 8QH

Manufacturer FORD
 Model CAPRI 3 Litre
 F.I.A. Recognition No. 5336
 Amendment No. 36/15E

Amendment to Form of Recognition

FEDERATION INTERNATIONALE DE L'AUTOMOBILE
VALID IN GROUP.....1.....

No.	Reference No.
	Evolution in Production
	Capri S fitted with front air dam see photo A 76
	Seat to same specification, but different external pleating see photo C 76
	Part-No of hub/disc assy has changed in 9053 204



A 76



C 76



Date amendment is valid from 1.11.76

Stamp of F.I.A./R.A.C.



MOTOR SPORT DIVISION
The Royal Automobile Club
31 Belgrave Square, London SW1X 8QH

Manufacturer FORD
 Model CAPRI 3 Litre
 F.I.A. Recognition No. 5336
 Amendment No. 37/22

Amendment to Form of Recognition

FEDERATION INTERNATIONALE DE L'AUTOMOBILE

VALID IN GROUP¹

No. Reference No.

Variant

Dual cylinder braking system (pedal box)

Part No. 9052599 - Hydraulic clutch

9053064 - Cable clutch

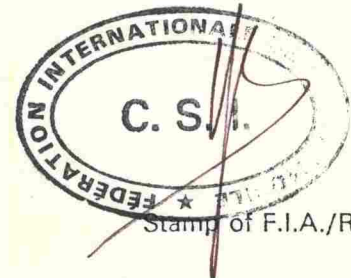
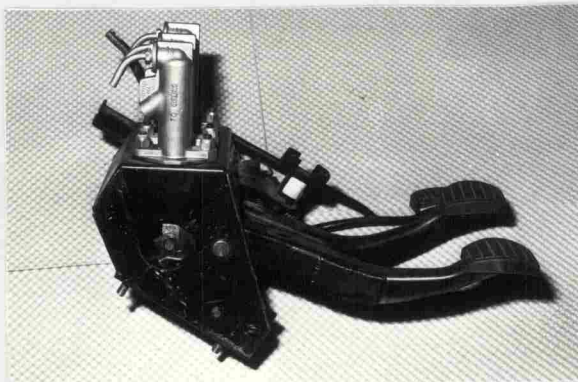

Date amendment is valid from 1/11/76

Stamp of F.I.A./R.A.C.



MOTOR SPORT DIVISION
The Royal Automobile Club
31 Belgrave Square, London SW1X 8QH

Manufacturer FORD
 Model CAPRI 3 Litre
 F.I.A. Recognition No. 5336
 Amendment No. 38/16 E

Amendment to Form of Recognition

FEDERATION INTERNATIONALE DE L'AUTOMOBILE

VALID IN GROUP¹

No. Reference No.

Evolution

~~.....~~

Clarification of previous evolution:

Track

Base Car	<u>Front</u>	<u>Rear</u>
Non-Vented Disc	1357 mm	1392 mm
+ 6" Rims	1369 mm	1404 mm
Vented Disc and 6" Rim	1399 mm	1404 mm

Date amendment is valid from 1/11/76





MOTOR SPORT DIVISION
The Royal Automobile Club
31 Belgrave Square, London SW1X 8QH

ManufacturerFORD.....
 ModelCAPRI 3 Litre.....
 F.I.A. Recognition No.5336.....
 Amendment No.[REDACTED].....

39/23V

Amendment to Form of Recognition

FEDERATION INTERNATIONALE DE L'AUTOMOBILE

Valid in Group 2

No.	Reference No.	"valable en Groupe 2 uniquement" "valid for Group 2 only"
	Pressure limiting Valve for rear brake circuit	
	Rear brake lock Valve (handbrake)	
	Heavy duty Axle with fully floating rear hub assembly. (Drum or Disc brake)	
	See Photo.	
	Rear Brake Caliper	
	Pt No SPE 1104	see photo G 76 - 10
	Pad Area = 2.84 in ²	
	Rear Brake Caliper	
	Pt No. CP 2361	see photo G 76 - 11
	Pad Area = 7.0 in ²	
	Alternative Front Caliper	
	Pt No. CP 2290	
	Pad Area = 9.36 in ²	see photo F 76 - 10

-1. JAN. 1977

Date amendment is valid from... [REDACTED]



Stamp of F.I.A./R.A.C



MOTOR SPORT DIVISION
The Royal Automobile Club
31 Belgrave Square, London SW1X 8QH

Manufacturer FORD
 Model CAPRI 3L
 F.I.A. Recognition No. 5336
 Amendment No. 39/23V

Amendment to Form of Recognition

FEDERATION INTERNATIONALE DE L'AUTOMOBILE

"valable en Groupe 2 uniquement"
"valid for Group 2 only"

Photographs must be 3" x 2" and a matt finish

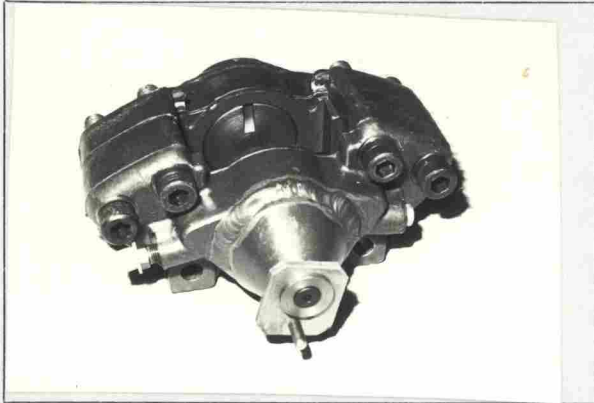

G76-10

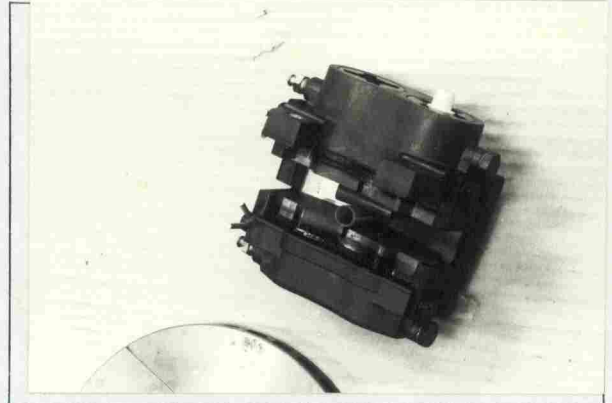

G76-11



F76-10

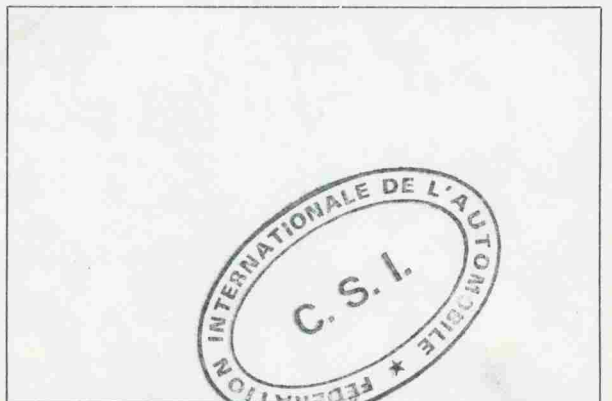
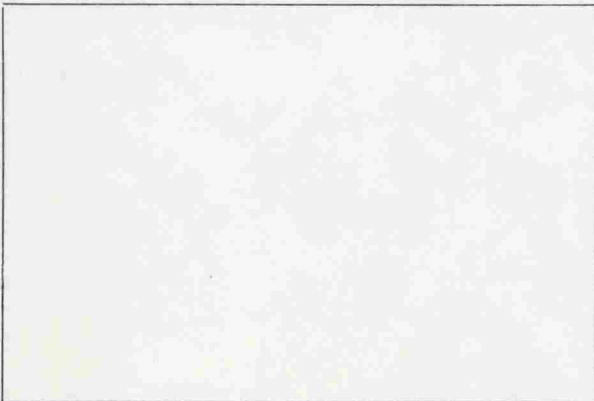
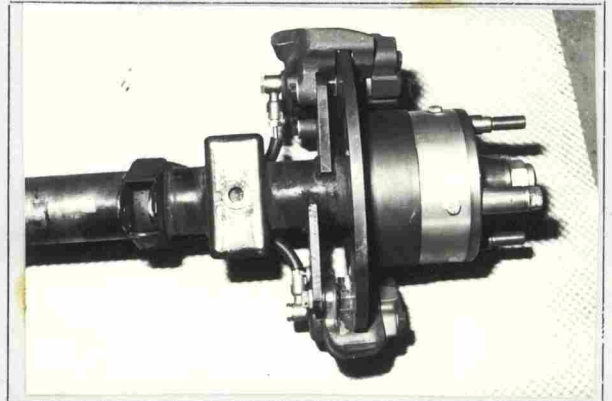

Date amendment is valid from.....

Stamp of F.I.A./R.A.C.



MOTOR SPORT DIVISION
The Royal Automobile Club
31 Belgrave Square, London SW1X 8QH

Manufacturer **FORD**.....
 Model ...**CAPRI 3 Litre**.....
 F.I.A. Recognition No. ...**5336**.....
 Amendment No. ...**40/17E**.....

Amendment to Form of Recognition

FEDERATION INTERNATIONALE DE L'AUTOMOBILE

Valid in Group 1

No.

Reference No.

Evolution

All inlet and exhaust tracts may be reclaimed by fettling.



-1. JAN. 1977

Date amendment is valid from.....

Stamp of F.I.A./R.A.C



MOTOR SPORT DIVISION
The Royal Automobile Club
31 Belgrave Square, London SW1X 8QH

Manufacturer FORD
 Model CAPRI 3 LITRE
 F.I.A. Recognition No. 5336
 Amendment No. 41/18E

Amendment to Form of Recognition

FEDERATION INTERNATIONALE DE L'AUTOMOBILE

VALID IN GROUP¹.....

No.	Reference No.		
	<u>ERRATUM</u>		
143	53,94 cc \pm	3,06	tolerance
		2,84	



-1. JAN. 1977

Date amendment is valid from.....

Stamp of F.I.A./R.A.C.



MOTOR SPORT DIVISION
The Royal Automobile Club
31 Belgrave Square, London SW1X 8QH

Manufacturer **FORD**
 Model **CAPRI 3 LITRE**
 F.I.A. Recognition No. **5336**
 Amendment No. **42/24V**

Amendment to Form of Recognition

FEDERATION INTERNATIONALE DE L'AUTOMOBILE
VALID IN GROUP1.....

No. | Reference No.

OPTIONAL EQUIPMENT

Modified fresh air intake

293 | Final drive ratio 3,89 : 1, number of teeth 35/9

41 | Sports seat Type "ASS-Scheel 302"

42 | Weight 10,5 kg

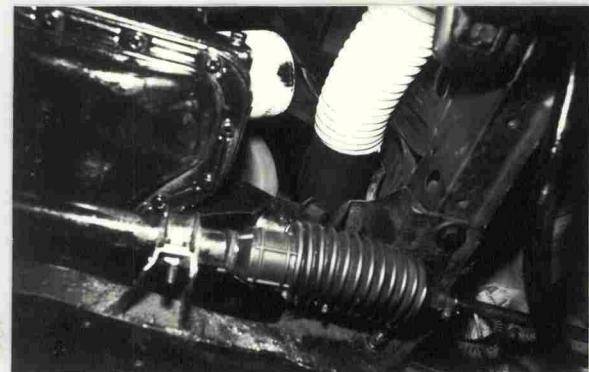
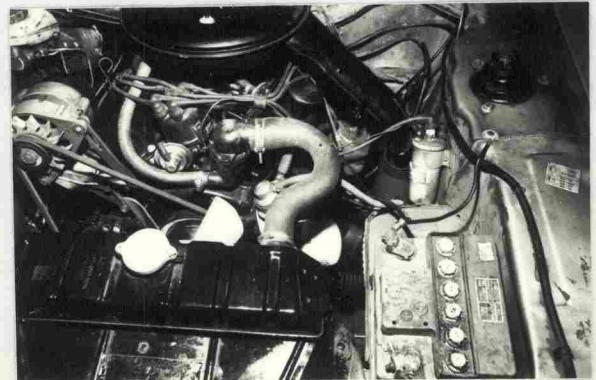

Date amendment is valid from.....**1.3.77**

Stamp of F.I.A./R.A.C.



MOTOR SPORT DIVISION
The Royal Automobile Club
31 Belgrave Square, London SW1X 8QH

Manufacturer FORD
 Model CAPRI 3 LITRE
 F.I.A. Recognition No. 5336
 Amendment No. 43/25V

Amendment to Form of Recognition

FEDERATION INTERNATIONALE DE L'AUTOMOBILE

VALID IN GROUP 2

No.

Reference No.

Dry Sump Lubrication Kit

Part No: FCO 693

No. of oil pumps - 2

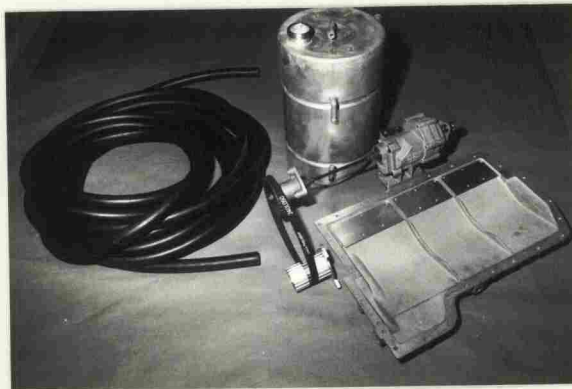

"valable en Groupe 2 uniquement"
"valid for Group 2 only"



Date amendment is valid from 1.7.77

Stamp of F.I.A./R.A.C.



MOTOR SPORT DIVISION
The Royal Automobile Club
31 Belgrave Square, London SW1X 8QH

Manufacturer FORD
 Model CAPRI 3 LITRE
 F.I.A. Recognition No. 5336
 Amendment No. 44/19E

Amendment to Form of Recognition

FEDERATION INTERNATIONALE DE L'AUTOMOBILE

VALID IN GROUP 1

No.	Reference No.
	Evolution in Production from January 1976
97.	Width of rear brake shoe $56 \pm 1.5\text{mm}$.
99.	Total swept area = 40220mm^2 .
100.	O D = 247.5mm. for optional ventilated disc. Supply Variant part which does not change swept area of existing brake.



Date amendment is valid from 1.7.77

Stamp of F.I.A./R.A.C.



MOTOR SPORT DIVISION
The Royal Automobile Club
 31 Belgrave Square, London SW1X 8QH

Manufacturer **FORD**
 Model **CAPRI 3L**
 F.I.A. Recognition No. **5336**
 Amendment No. **45/26V**

Amendment to Form of Recognition

FEDERATION INTERNATIONALE DE L'AUTOMOBILE

VALID IN GROUP 1

No.

Reference No.

VARIANTS

Current exhaust systems - alternative suppliers - see photo 178.1

Redesigned oil cooler kit

Redesigned sports road wheel - see photo B78.1 & 2
 (Use restricted to low section tyres)

- 50 - Alum alloy
- 51 5.25 kg.
- 53 330 mm.
- 54 178 mm.

Reinforced front roll bar mounting - see photo D78.1

Rear deck lid spoiler - see photo B78.2





MOTOR SPORT DIVISION
The Royal Automobile Club
 31 Belgrave Square, London SW1X 8QH

Manufacturer FORD
 Model CAPRI 3 LITRE
 F.I.A. Recognition No. 5336
 Amendment No. 45/26V

Amendment to Form of Recognition

FEDERATION INTERNATIONALE DE L'AUTOMOBILE

Valid in Group 1

Photographs must be 3" x 2" and a matt finish

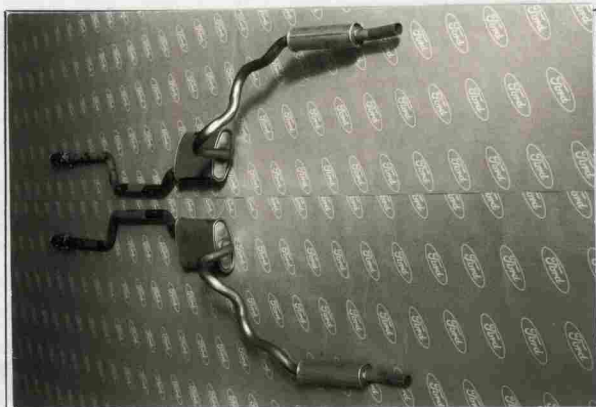

I78-1

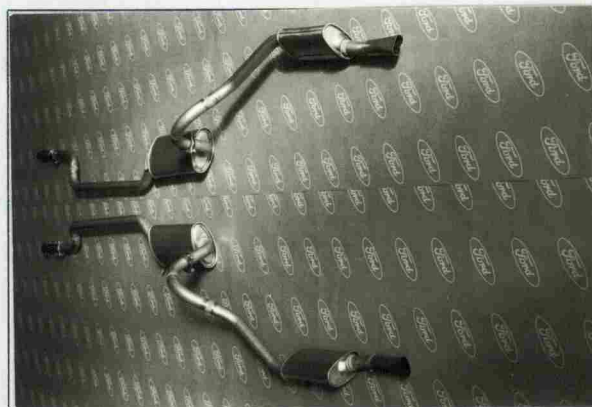

I78-1



B78-1



B78-2



D78-1



Date amendment is valid from.....

Stamp of F.I.A./R.A.C.



MOTOR SPORT DIVISION
The Royal Automobile Club
31 Belgrave Square, London SW1X 8QH

Manufacturer FORD
 Model CAPRI 3L
 F.I.A. Recognition No. 5336
 Amendment No. 46/20E

Amendment to Form of Recognition

FEDERATION INTERNATIONALE DE L'AUTOMOBILE

VALID IN GROUP1.....

No.

Reference No.

Evolution in Production

Minor styling changes, including 4 headlamps and boot lid spoiler
 see photo's A78.1; B78.1; & C78.1



A78.1



B78.1



FÉDÉRATION INTERNATIONALE DE L'AUTOMOBILE

FICHE D'EXTENSION D'HOMOLOGATION
CONFORME A L'ANNEXE J DU CODE SPORTIF INTERNATIONAL

Marque FORD Modèle Capri 3L

Numéros de série inaugurant les modifications décrites : Châssis/Carrosserie _____

Moteur _____

Date de sortie des premiers véhicules construits avec les modifications : _____ 19 _____

Dénomination commerciale après application des modifications : _____

Cette extension d'homologation doit être considérée comme : variante - évolution normale du type.

L'homologation est valable du 1.4. 19 78 Liste _____

Descriptions des modifications :

ERRATA

The following weights should be taken into account for the following extensions:

12/6E	Capri I GT	:	1002	kg
20/9E	Capri II GT	:	1051	kg
20/9E	Capri II Ghia	:	1110	kg
34/20V	Capri II S	:	1051	kg
46/20E	Capri III S	:	1062	kg



Signature et cachet
de l'Autorité Sportive Nationale :

Signature et cachet de la F.I.A. :



MOTOR SPORT DIVISION
The Royal Automobile Club
 31 Belgrave Square, London SW1X 8QH

Manufacturer FORD
 Model CAPRI 3 LITRE
 F.I.A. Recognition No. 5336
 Amendment No. 48/22E

-1. JUIN 1978

Amendment to Form of Recognition

FEDERATION INTERNATIONALE DE L'AUTOMOBILE

VALID IN GROUP.....1.....

No. Reference No.

Information omitted on 45/26V

Track for 178 mm wide rims = 31 mm increase on the values
 quoted for 6" rim - see sheet 38/166.

178 mm rim + vented disc = 1430 front; 1435 rear





MOTOR SPORT DIVISION
 The Royal Automobile Club
 31 Belgrave Square, London SW1X 8QH

Manufacturer FORD
 Model CAPRI 3 LITRE
 F.I.A. Recognition No. 5336
 Amendment No. 48/271

-1.JUL.1978

Amendment to Form of Recognition

FEDERATION INTERNATIONALE DE L'AUTOMOBILE

VALID IN GROUP.....1.....

No. Reference No.

Product Variant

Cost and weight saving exercises, plus multi sourcing have resulted in the following weight changes.

- 160 Flywheel 8.8 kg.
- 161 Flywheel and clutch (weights clean, without bolts, washers, etc...)
 depending on clutch manufacturer :
 - a) Clutch pressure plate assembly:
 - Borg and Beck : 5.8 kg
 - Laycock : 6.6 kg
 - b) Clutch driven plate:
 - Laycock : 1.4 kg
 - Borg and Beck : 1.8 kg
- 162 Crank 17.1 kg.
- 164 Piston (ref page 29/17V) = .63 kg. Mahle
 .73 kg. H & G





MOTOR SPORT DIVISION
The Royal Automobile Club
31 Belgrave Square, London SW1X 8QH

Manufacturer FORD
 Model CAPRI 3 L
 F.I.A. Recognition No. 5336
 Amendment No. 50/23F

-1. JAN. 1979

Amendment to Form of Recognition

FEDERATION INTERNATIONALE DE L'AUTOMOBILE

VALID IN GROUP1.....

No.

Reference No.

Evolution in Production

Exhaust System

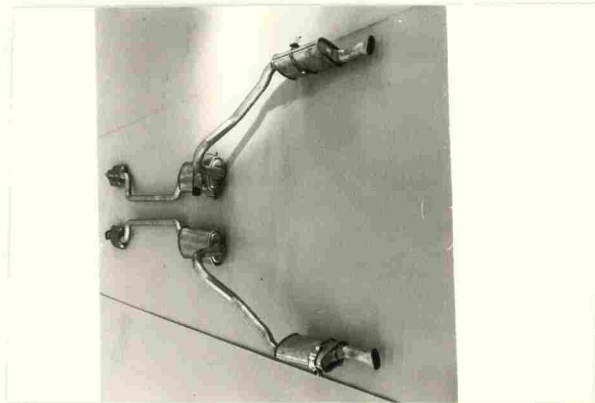

Caliper for ventilated front disc

Width of brake lining 98 mm

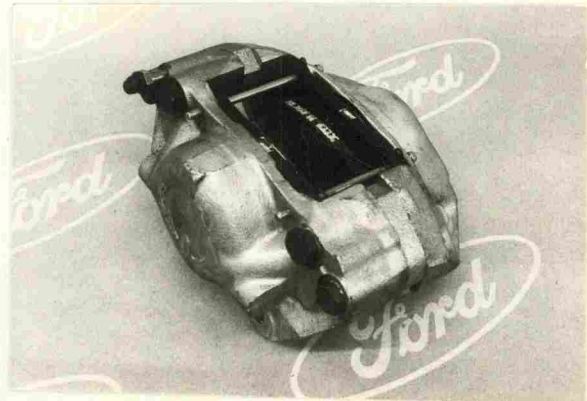



MOTOR SPORT DIVISION
The Royal Automobile Club
 31 Belgrave Square, London SW1X 8QH

Manufacturer FORD

Model CAPRI 3L

F.I.A. Recognition No. 5336

Amendment No. 51/28V

Amendment to Form of Recognition

FEDERATION INTERNATIONALE DE L'AUTOMOBILE

VALID IN GROUP 1

No.

Reference No.

Optional Equipment

Heavy duty crossmember Part no: H74EB 5019 AA

photo 1

Heavy duty radiator Part no: H78EB 8005 AA

photo 2

Cars fitted with Power Steering have crossmember part no:
 74EB 5019 CA/78EB 5019 BA.

photo 3



[Handwritten signature]

Date amendment is valid from..... -1. MAR. 1979

Stamp of F.I.A./R.A.C.



MOTOR SPORT DIVISION
 The Royal Automobile Club
 31 Belgrave Square, London SW1X 8QH

Manufacturer
 Model Capri 3L
 F.I.A. Recognition No. 5336
 Amendment No. 52/29V

Amendment to Form of Recognition

FEDERATION INTERNATIONALE DE L'AUTOMOBILE

VALID IN GROUP.....1.....

No.

Reference No.

Dual circuit braking - see also amendment sheet 37/22

Type A - no servo

Type B - with servo units fitted in hydraulic line between master cylinder & brakes.

Actuating force - vacuum - complies with Art. 258i 1979



-1. Apr. 1980

Date amendment is valid from

Stamp of F.I.A./R.A.C.



BRITISH MOTOR SPORTS COUNCIL
31 Belgrave Square, London SW1X 8QH

Manufacturer FORD

Model Capri 3L

F.I.A. Recognition No. 5336.....

Amendment No. 53/25 V

Amendment to Form of Recognition

FEDERATION INTERNATIONALE DE L'AUTOMOBILE

Valid in Group 1

No. Reference No.

Alternative final drive ratio = 3.56. No. of teeth 32/9.

Revised front strut top mounts for heavy duty suspension kit - see photo D80-1

Rear brake circuit pressure limiting valve - required in certain territories with Kit on Amendment sheet 28/16V - see photo G80-1.

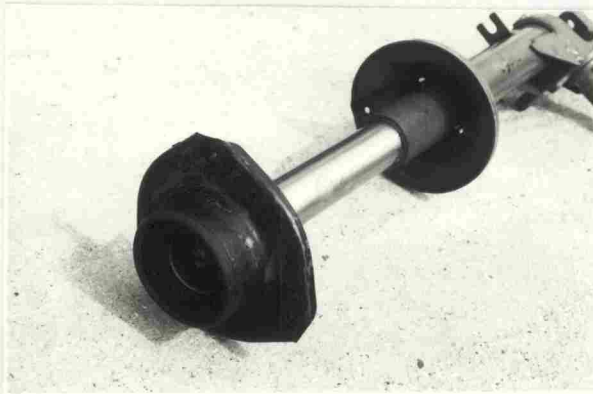

D80-1



G80-1



[Handwritten signature]

Date amendment is valid from.....-1 JAN.1981.....

Stamp of F.I.A./R.A.C



MOTOR SPORT DIVISION
The Royal Automobile Club
31 Belgrave Square, London SW1X 8QH

Manufacturer **FORD**
Model **CAPRI**
F.I.A. Recognition No. **5336**
Amendment No. **54/26V**

Amendment to Form of Recognition

FEDERATION INTERNATIONALE DE L'AUTOMOBILE

VALID IN GROUP 2

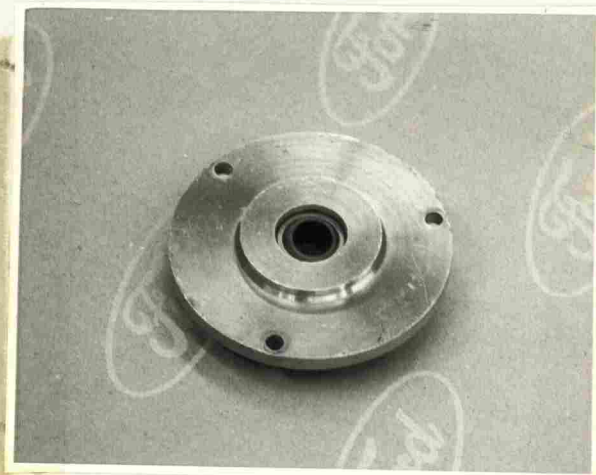

"valable en Groupe 2 uniquement"
"valid for Group 2 only"





MOTOR SPORT DIVISION
The Royal Automobile Club
31 Belgrave Square, London SW1X 8QH

Manufacturer **FORD**
 Model **CAPRI**
 F.I.A. Recognition No. **5336**
 Amendment No. **54/26V**

Amendment to Form of Recognition

FEDERATION INTERNATIONALE DE L'AUTOMOBILE
VALID IN GROUP.....2.....

No.	Reference No.
	Front brake caliper (aluminium) No. 18/4-1/2-13-S
102	96 mm
103	51 mm
104	2

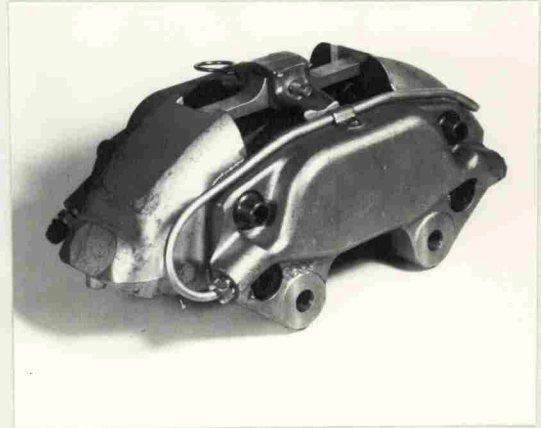

	Ventilated brake disc front
100	304,8 mm
101	27,9 mm
105	40804 mm ²



"valable en Groupe 2 uniquement"
 "valid for Group 2 only"

Reinforced front suspension system incorporating

Altered roll bar
 Reinforced roll bar mounting
 Reinforced chassis member
 Reinforced top mount

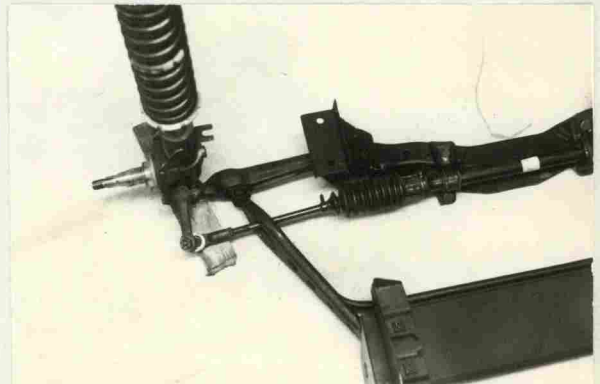

Date amendment is valid from.....1.FEV.1961

Stamp of F.I.A./R.A.C.