



FEDERATION INTERNATIONALE
DE L'AUTOMOBILE

Homologation N°

F3 - 330

FICHE D'HOMOLOGATION POUR MOTEUR DE FORMULE 3
HOMOLOGATION FORM FOR FORMULA 3 ENGINE

Constructeur / Manufacturer: DAIMLERCHRYSLER AG

Modèle et type / Model and type: Mercedes-Benz M 271

Homologation valable à partir du / Homologation valid as from: 01 AVR. 2002

**MOTEUR (version standard)
ENGINE (standard version)**

Cycle: 4 stroke

Nombre et disposition des cylindres / Number and layout of the cylinders: 4 in line

Mode de refroidissement / Cooling system: water

Cylindrée / Cylinder capacity: Unitaire / Unitary: 449 cm³; Totale / Total: 1796 cm³

Matériau du bloc cylindres / Cylinder block material: aluminium alloy

Chemises / Sleeves: oui / yes; Type: cast iron

Alésage / Bore: 82 mm; Course / Stroke: 85 mm

Fédération Internationale de l'Automobile
- 2 chemin de Blandonnet
CH-1190 GENEVE 15
Tél.: +41 22 544 44 00
Fax Sport: +41 22 544 44 50

Marque **Mercedes-Benz** Modèle **M 271**
 Make **Mercedes-Benz** Model **M 271**

F3 - 330

**Vilebrequin :
Crankshaft :**

Type de paliers plain
 Type of bearings _____

Matériau des chapeaux de paliers cast iron
 Bearing cap material _____

**Culasse :
Cylinder head :**

Nombre 1 Emplacement top
 Number _____ Location _____

Système de commande des soupapes rocker arm
 Type of valve operation _____

Angle entre axe de la soupape d'admission et axe de la soupape d'échappement 37 degs
 Angle between inlet valve axle and exhaust valve axle _____

**Admission :
Inlet :**

Nombre de soupapes par cylindre 2 Type des ressorts de soupape steel coil spring
 Number of valves per cylinder _____ Type of valve springs _____

**Echappement :
Exhaust :**

Nombre de soupapes par cylindre 2 Type des ressorts de soupape steel coil spring
 Number of valves per cylinder _____ Type of valve springs _____

PHOTOS

Culasse nue vue de dessus
 Bare cylinder head seen from above

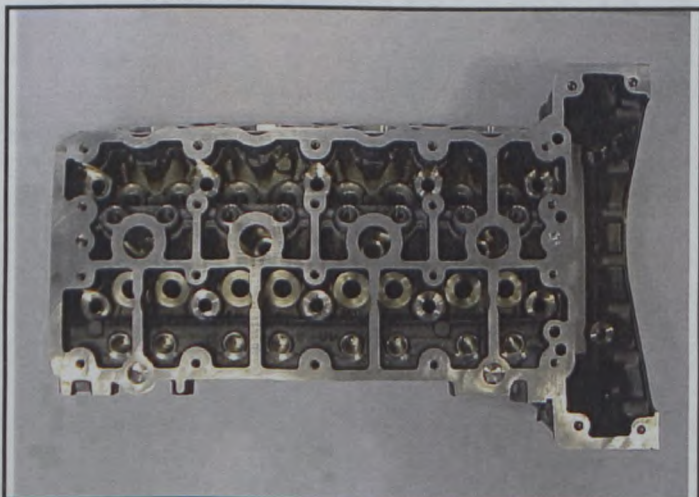

Culasse nue vue de dessous
 Bare cylinder head seen from below

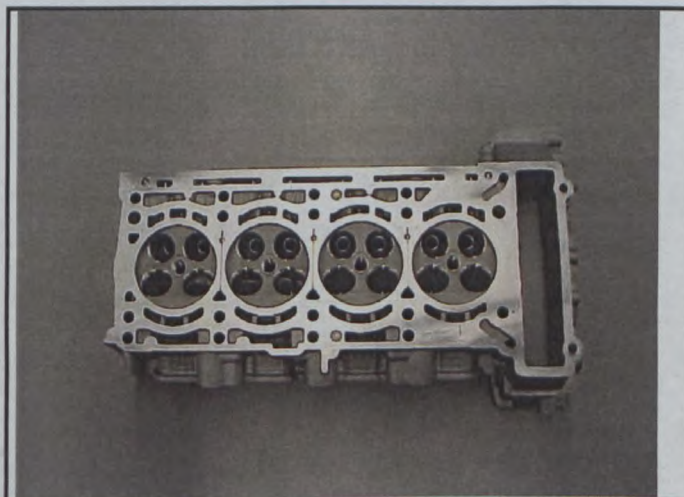

Marque

Modele

Make Mercedes-Benz

Model

M271

F3 - 330

Profil droit de culasse nue
Right hand view of bare cylinder head

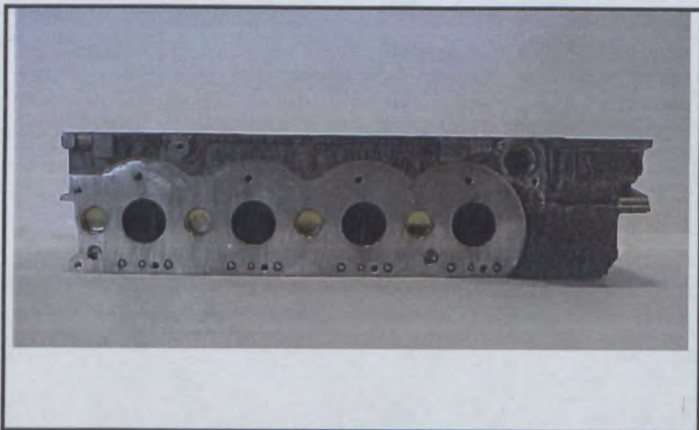

Profil gauche de culasse nue
Left hand view of bare cylinder head

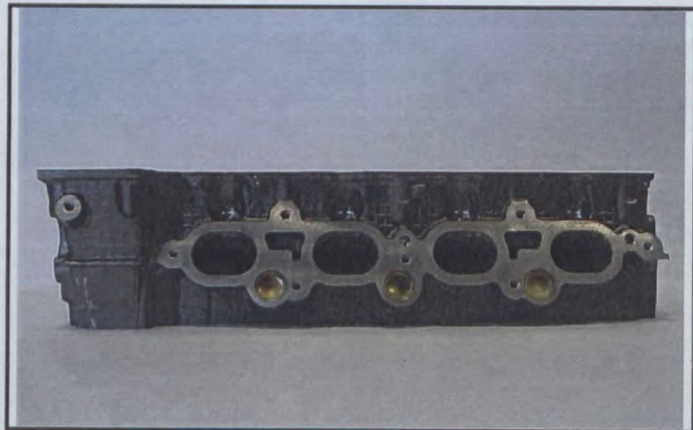

Bloc nu vu de dessus
Bare block seen from above

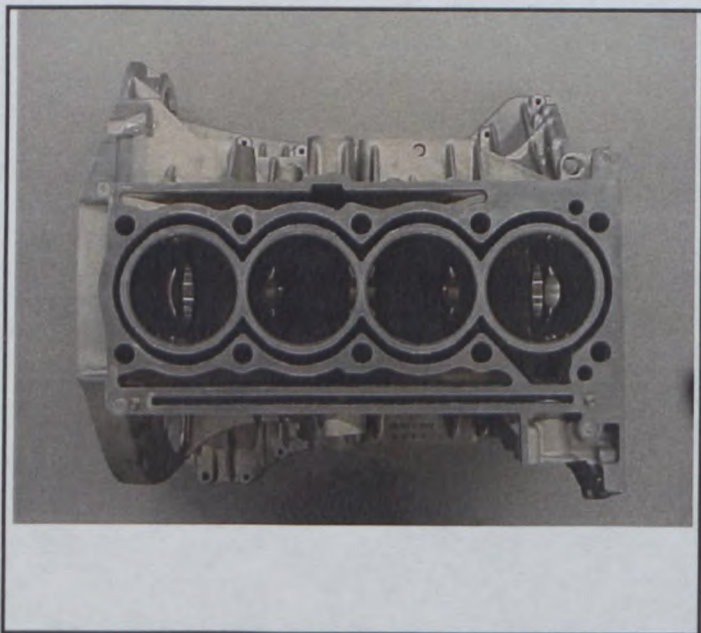

Bloc nu vu de dessous
Bare block seen from below

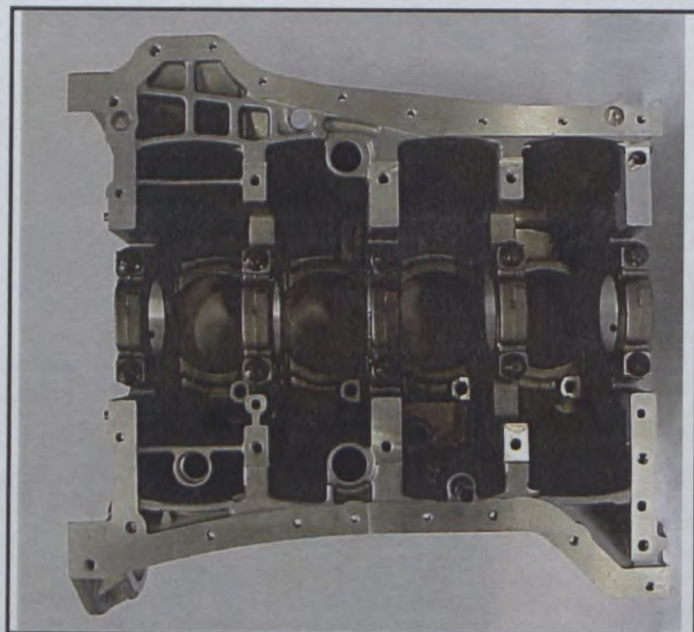

Profil droit du bloc nu
Right hand view of bare block

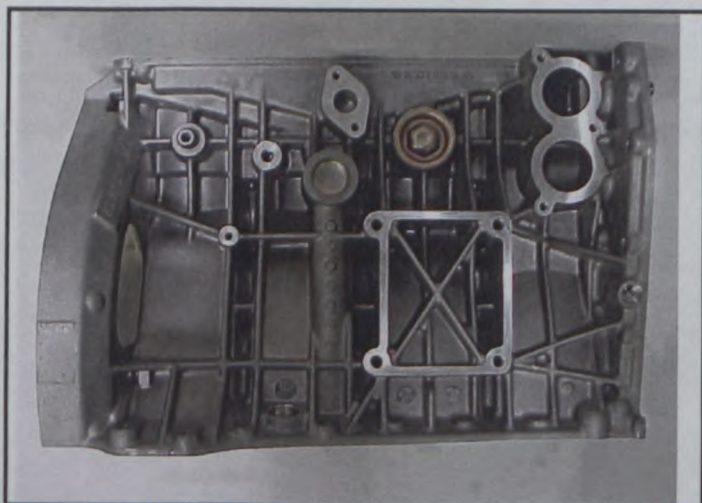

Profil gauche du bloc nu
Left hand view of bare block

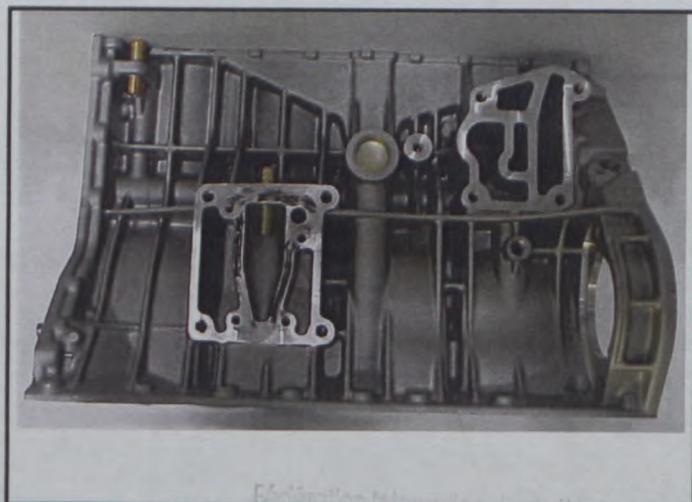



FEDERATION INTERNATIONALE DE L'AUTOMOBILE

Homologation N°

F3-330

Groupe

Group

F3

Extension N°

01/01 ET

FICHE D'EXTENSION D'HOMOLOGATION HOMOLOGATION EXTENSION FORM

- ES** Evolution sportive du type / Sporting evolution of the type
 VO Variante option / Option variant
 ET Evolution normale du type / Normal evolution of the type
 VP Variante de Production / Production variant
 ER Erratum / Erratum

Homologation valable à partir du
Homologation valid as from

01 JUL. 2007

Véhicule : Constructeur
Vehicle : Manufacturer

DAIMLERCHRYSLER

Modèle et type
Model and type

Mercedes-Benz M271

Page or ext.	Article	Description																																													
2		<p>Cylinder head with M12x1.25 tapped bore of the spark plug</p> <p>Schnitt durch Zündkerzenschacht</p> <p>M12x1.25</p> <p>Ø19</p> <table border="1"> <thead> <tr> <th>Änderungsindex / Änderungsbildung / Planquadrat</th> <th>CAD</th> <th>ZUS</th> <th>Bearb. / Auth.</th> <th>Datum/Date</th> </tr> </thead> <tbody> <tr> <td>Format / Maßstab/Scale</td> <td></td> <td></td> <td></td> <td></td> </tr> <tr> <td>Material / (Final) conditions</td> <td></td> <td></td> <td></td> <td></td> </tr> <tr> <td>Bezeichnung / Title</td> <td></td> <td></td> <td></td> <td></td> </tr> <tr> <td>Sach-Nr. / Basic number</td> <td></td> <td></td> <td></td> <td></td> </tr> <tr> <td>Bezeichnung</td> <td></td> <td></td> <td></td> <td></td> </tr> <tr> <td>Sprache / lang.</td> <td></td> <td></td> <td></td> <td></td> </tr> <tr> <td>System</td> <td></td> <td></td> <td></td> <td></td> </tr> <tr> <td>Version</td> <td></td> <td></td> <td></td> <td></td> </tr> </tbody> </table>	Änderungsindex / Änderungsbildung / Planquadrat	CAD	ZUS	Bearb. / Auth.	Datum/Date	Format / Maßstab/Scale					Material / (Final) conditions					Bezeichnung / Title					Sach-Nr. / Basic number					Bezeichnung					Sprache / lang.					System					Version				
Änderungsindex / Änderungsbildung / Planquadrat	CAD	ZUS	Bearb. / Auth.	Datum/Date																																											
Format / Maßstab/Scale																																															
Material / (Final) conditions																																															
Bezeichnung / Title																																															
Sach-Nr. / Basic number																																															
Bezeichnung																																															
Sprache / lang.																																															
System																																															
Version																																															

Fédération Internationale de l'Automobile
Chemin de Blandanet, 2
CH-1216 GENEVE 15
Tél.: 41 22 544 44 00
Fax Sport: 41 22 544 44 50

Marque
Make MERCEDES-BENZ

Modèle
Model M271

Homologation N°

F3-330

Extension N°

01/01 ET

PHOTO N° 1 Bare cylinder head seen from above

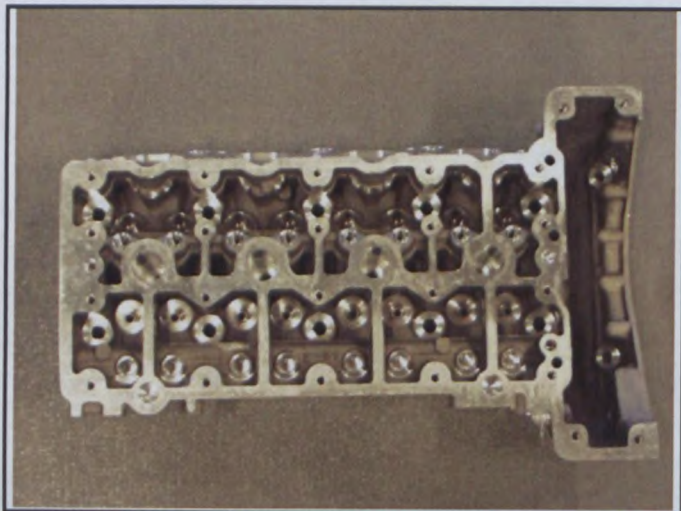

PHOTO N° 2 Bare cylinder head seen from below

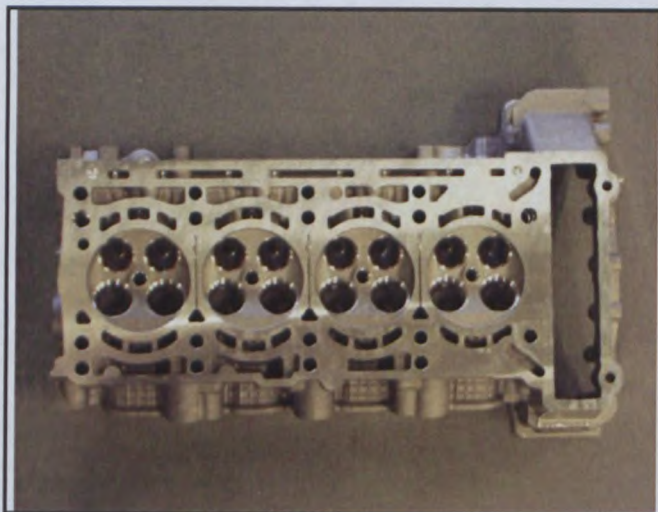

PHOTO N° 3 Right hand view of bare cylinder head

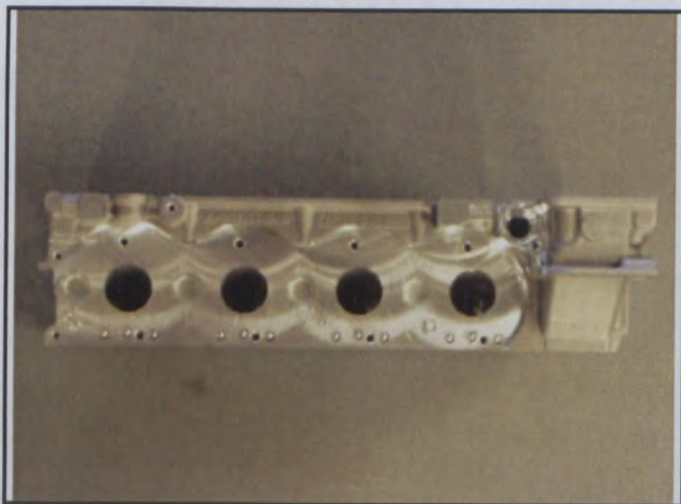

PHOTO N° 4 Left hand view of bare cylinder head

