



FEDERATION INTERNATIONALE
DU SPORT AUTOMOBILE

Homologation No

313

EF3 - 008 - 93

FICHE D'HOMOLOGATION POUR MOTEUR DE FORMULE 3 1993年8月31日
HOMOLOGATION FORM FOR FORMULA 3 ENGINE

Constructeur / Manufacturer: HONDA MOTOR CO., LTD Modèle et type / Model and type: B18C ENGINE

Homologation valable à partir du / Homologation valid as from: 01 OCT. 1993

MOTEUR (version standard)
ENGINE (standard version)

Cycle: 4-Stroke (OTTO)

Nombre et disposition des cylindres / Number and layout of the cylinders: 4-in line

Mode de refroidissement / Cooling system: Liquid

Cylindrée: Unitaire / Cylinder capacity: Unitary 449.5 cm³ Totale / Total 1,798.0 cm³

Matériau du bloc cylindres / Cylinder block material: Aluminum-alloy

Chemises / Sleeves:

oui / yes	non / no
-----------	---------------------

 Type: Dry

Alésage / Bore: 81.0 mm Course / Stroke: 87.2 mm

Vilebrequin / Crankshaft:

Type de paliers / Type of bearings: Plain

Matériau des chapeaux de paliers / Bearing cap material: Cast-iron



Marque
Make HONDA

Modèle
Model B18C ENGINE

Homologation No

313

EF3 - 008 - 93

Vilebrequin :
Crankshaft :

Type de paliers
Type of bearings XXXX

Matériau des chapeaux de paliers
Bearing cap material XXXX

Culasse :
Cylinder head :

Nombre
Number 1 Emplacement
Location Top (DOHC)

Système de commande des soupapes
Type of valve operation Rocker arm

Angle entre axe de la soupape d'admission et axe de la soupape d'échappement
Angle between inlet valve axle and exhaust valve axle 56°

Admission :
Inlet :

Nombre de soupapes par cylindre
Number of valves per cylinder 2 Type des ressorts de soupape
Type of valve springs Coil

Exhappement :
Exhaust :

Nombre de soupapes par cylindre
Number of valves per cylinder 2 Type des ressorts de soupape
Type of valve springs Coil

PHOTOS

Culasse nue vue de dessus
Bare cylinder head seen from above

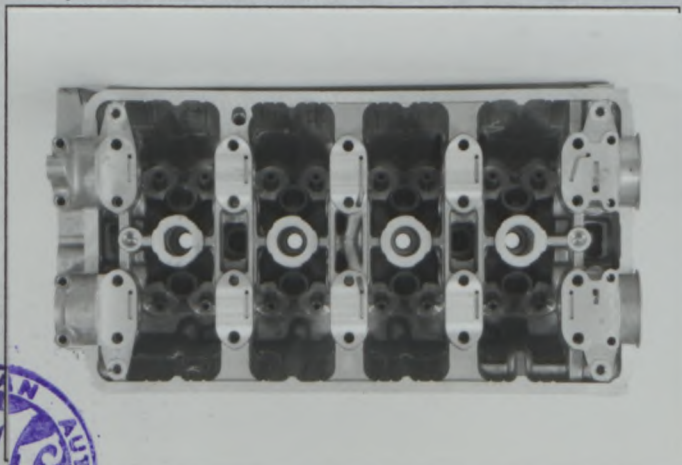

Culasse nue vue de dessous
Bare cylinder head seen from below

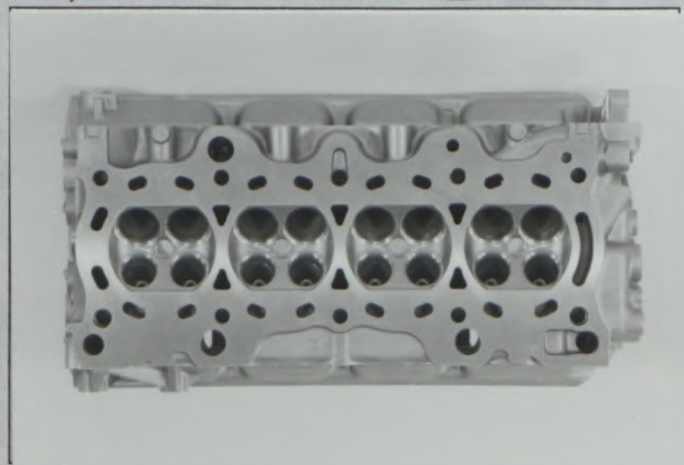

Marque
Make

HONDA

Modèle
Model

B18C ENGINE

Homologation No

313

EF3 - 008 - 93

Profil droit de culasse nue
Right hand view of bare cylinder head

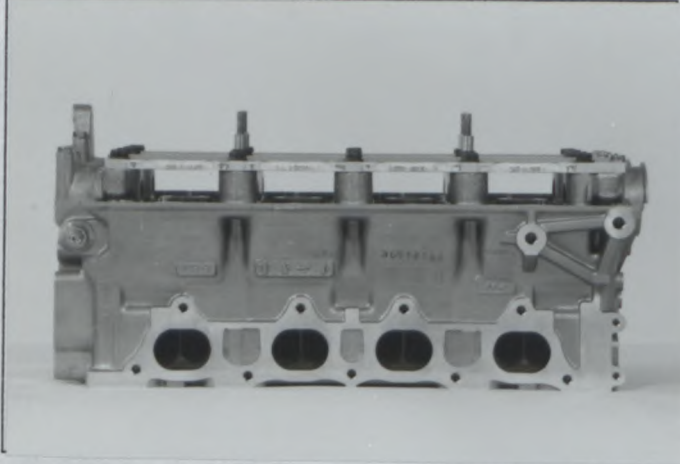

Profil gauche de culasse nue
Left hand view of bare cylinder head

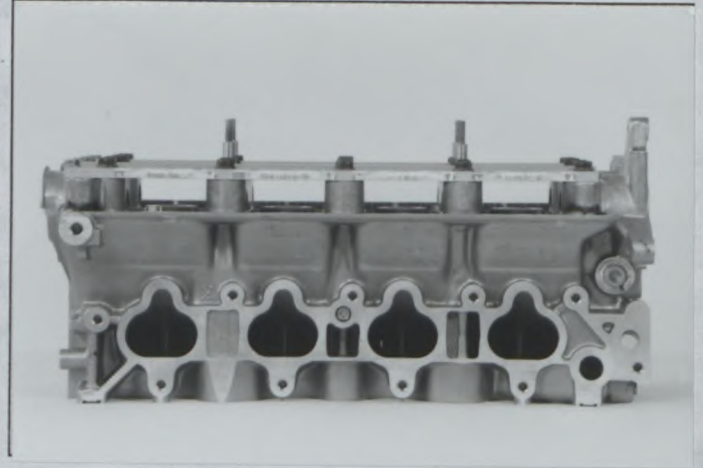

Bloc nu vu de dessus
Bare block seen from above

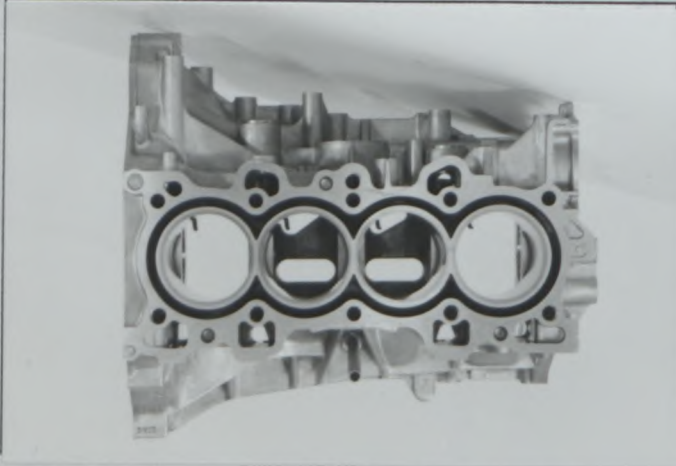

Bloc nu vu de dessous
Bare block seen from below

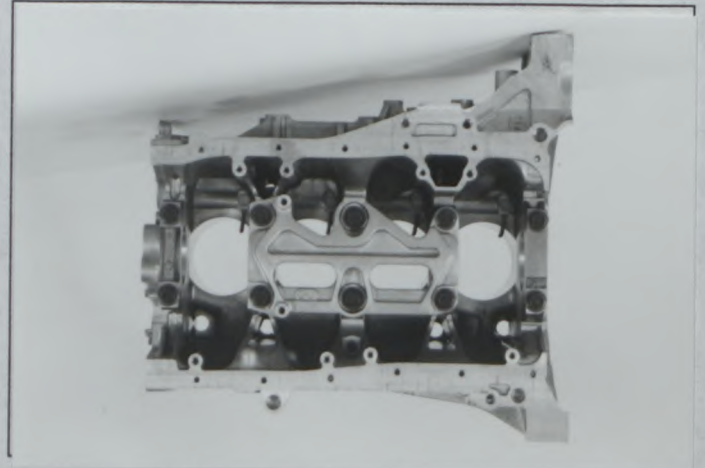

Profil droit du bloc nu
Right hand view of bare block

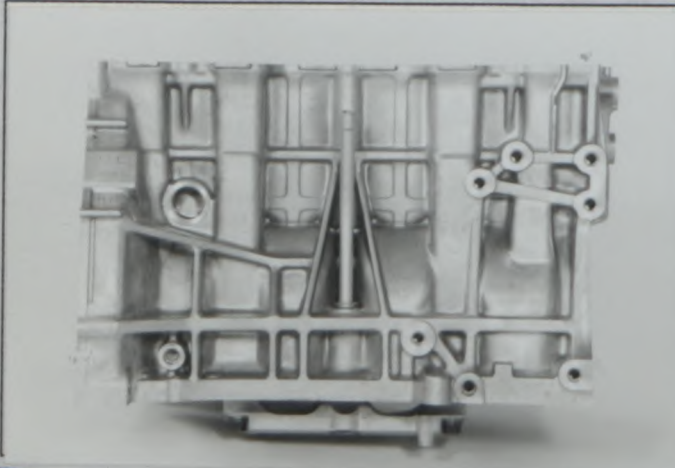

Profil gauche du bloc nu
Left hand view of bare block

