



FEDERATION INTERNATIONALE
DE L'AUTOMOBILE

Homologation N°

F3-329

FICHE D'HOMOLOGATION POUR MOTEUR DE FORMULE 3
HOMOLOGATION FORM FOR FORMULA 3 ENGINE

Constructeur / Manufacturer **Ford Motor Company**

Modèle et type / Model and type **Zetec SE Engine**

Homologation valable à partir du / Homologation valid as from **1st July 2001**

MOTEUR (version standard)
ENGINE (standard version)

Cycle / Cycle **4 Stroke**

Nombre et disposition des cylindres / Number and layout of the cylinders **In-Line**

Mode de refroidissement / Cooling system **Liquid**

Cylindrée / Cylinder capacity
Unitaire / Unitary **419.72** cm³ Totale / Total **1678.87** cm³

Matériau du bloc cylindres / Cylinder block material **Aluminium Alloy**

Chemises / Sleeves :

oui / yes	non / no
X	

 Type / Type **Electroplated Cylinder bore**

Alésage / Bore **80.0 mm** Course / Stroke **83.5 mm**

Marque
Make **Ford Motor Company**

Modèle
Model **Zetec SE Engine**

F3-329

Vilebrequin :
Crankshaft :

Type de paliers
Type of bearings **Plain**

Matériau des chapeaux de paliers
Bearing cap material **Aluminium Alloy**

Culasse :
Cylinder head :

Nombre
Number **1** Emplacement
Location

Système de commande des soupapes
Type of valve operation **Direct Tappet**

Angle entre axe de la soupape d'admission et axe de la soupape d'échappement
Angle between inlet valve axle and exhaust valve axle **41.5 deg + or - 15 min**

Admission :
Inlet :

Nombre de soupapes par cylindre
Number of valves per cylinder **2** Type des ressorts de soupape
Type of valve springs **Coil Spring**

Echappement :
Exhaust :

Nombre de soupapes par cylindre
Number of valves per cylinder **2** Type des ressorts de soupape
Type of valve springs **Coil Spring**

PHOTOS

Culasse nue vue de dessus
Bare cylinder head seen from above

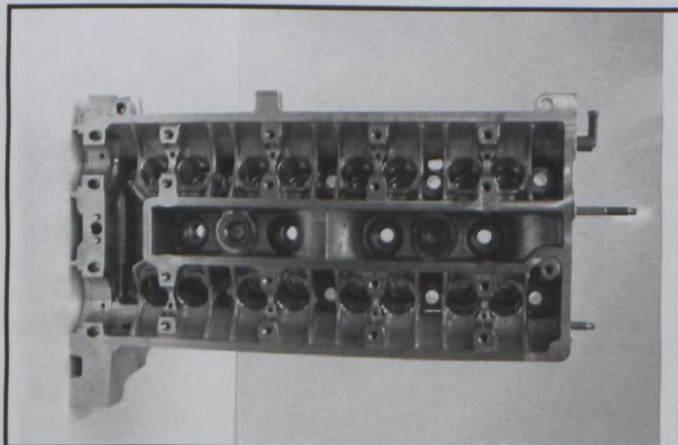

Culasse nue vue de dessous
Bare cylinder head seen from below

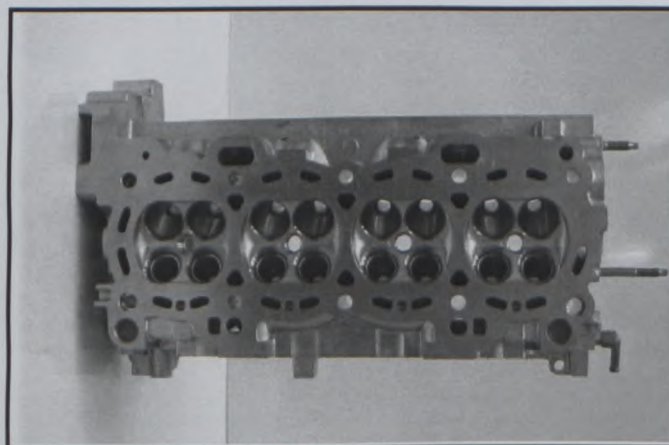

Marque
Make **Ford Motor Company**

Modèle
Model

Zetec SE Engine

F3- 3 2 9

Profil droit de culasse nue
Right hand view of bare cylinder head

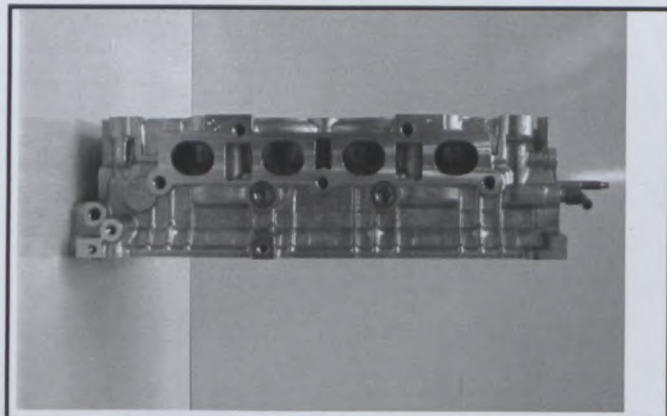

Profil gauche de culasse nue
Left hand view of bare cylinder head

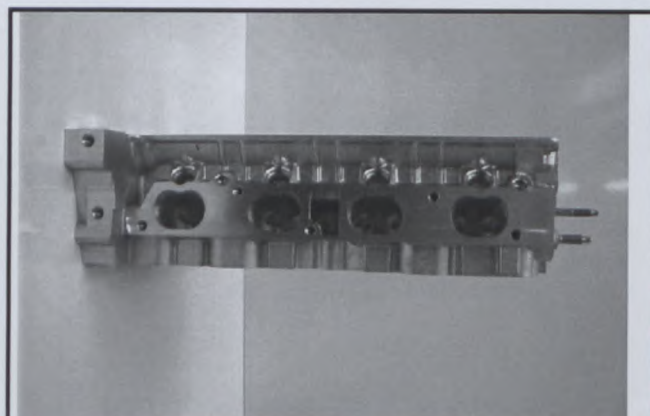

Bloc nu vu de dessus
Bare block seen from above

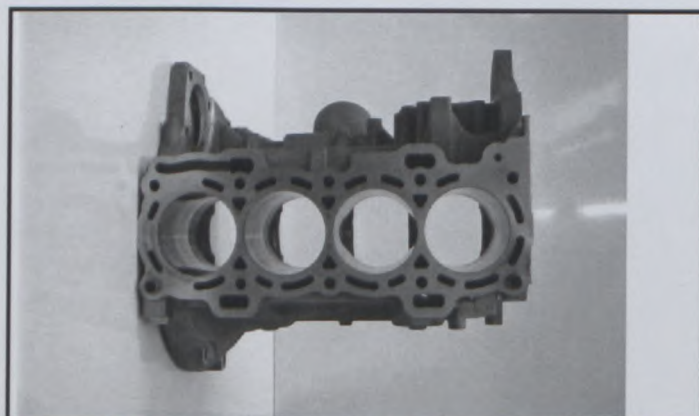

Bloc nu vu de dessous
Bare block seen from below

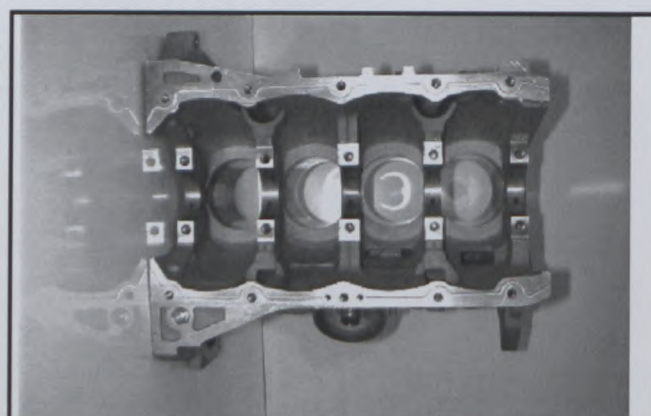

Profil droit du bloc nu
Right hand view of bare block

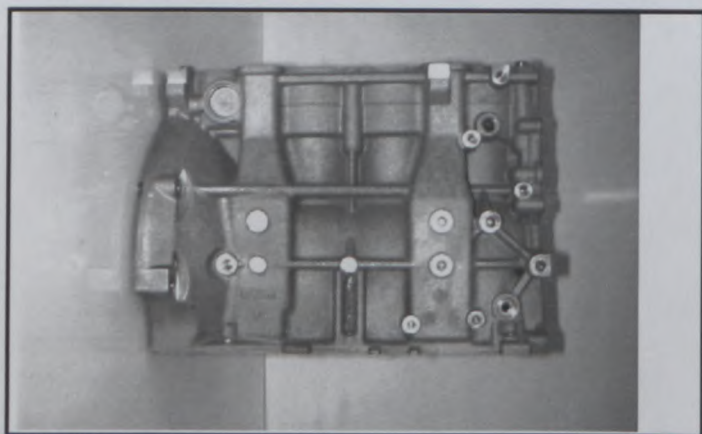

Profil gauche du bloc nu
Left hand view of bare block

