

325. Arbre à cames : a) Nombre 2 b) Emplacement en tête - overhead
 Camshaft : Number Location
- d) Système de commande des soupapes directe - direct
 Type of valve operation
327. Admission : c) Nombre de soupapes par cylindre 2
 Intake : Number of valves per cylinder
328. Echappement : d) Nombre de soupapes par cylindre 2
 Exhaust : Number of valves per cylinder

FEDERATION INTERNATIONALE
 DE L'AUTOMOBILE
 8, place de la Concorde, 75008 Paris
 Services Administratifs :
 8 bis, rue Boissy d'Anglas, 75008 Paris

PHOTOS

C) Profil droit du moteur déposé
Right hand view of dismantled engine

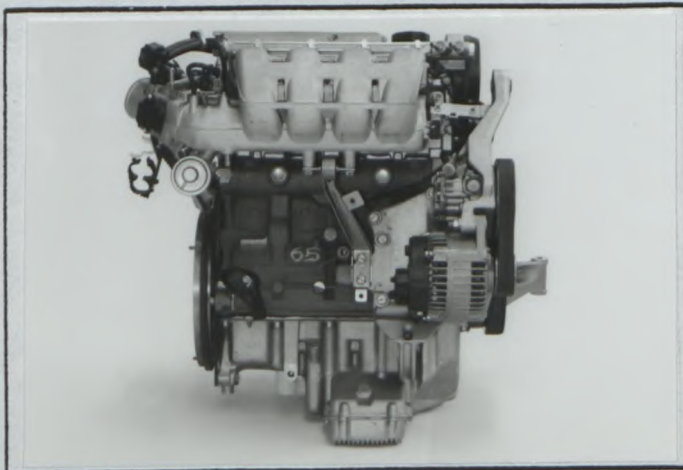

D) Profil gauche du moteur déposé
Left hand view of dismantled engine

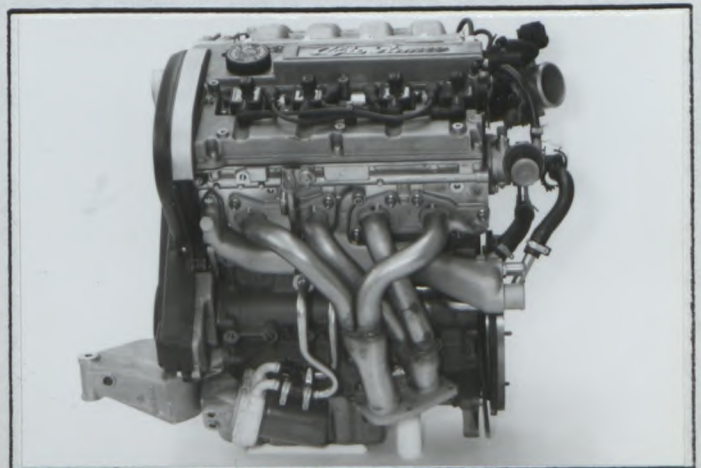

F1) Culasse nue vue de dessus
Bare cylinderhead seen from above

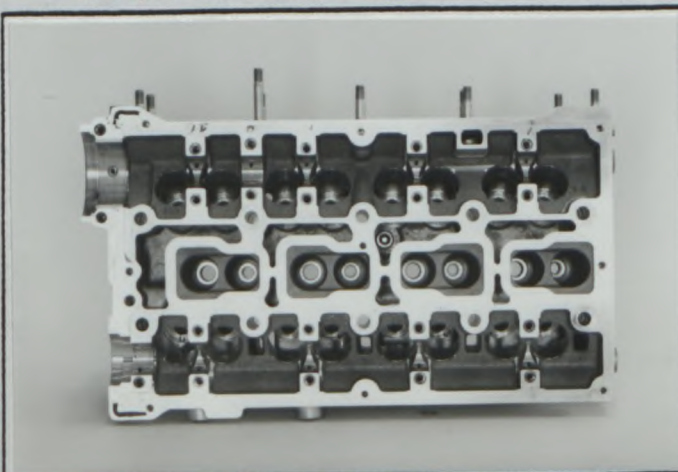

F2) Culasse nue vue de dessous
Bare cylinderhead seen from below

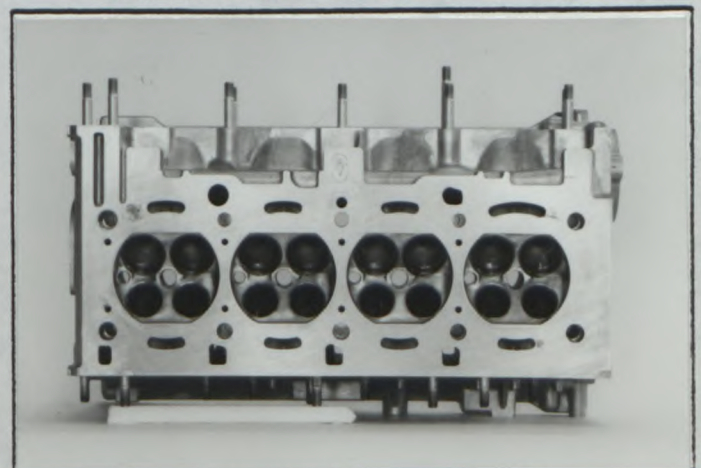

Marque
Make

ALFA ROMEO

Modèle
Model

155 2.0 T. SPARK Super

16 V

C2- 29

F1) Profil droit de culasse nue
Right hand view of bare cylinderhead

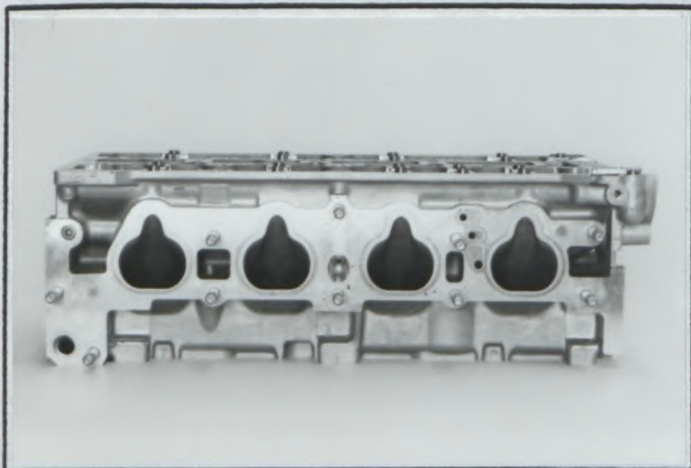

F2) Profil gauche de culasse nue
Left hand view of bare cylinderhead

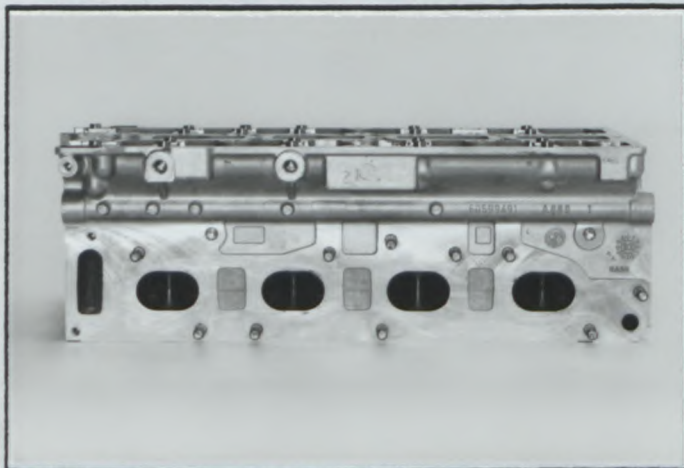

C1) Bloc nu vu de dessus
Bare block seen from above

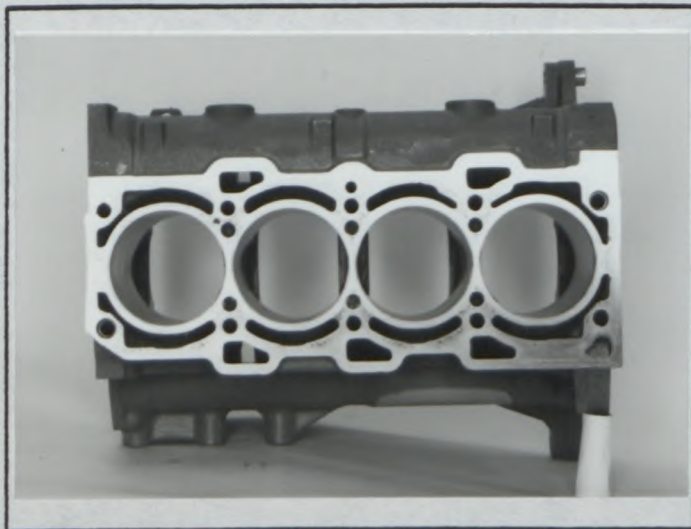

C2) Bloc nu vu de dessous
Bare block seen from below

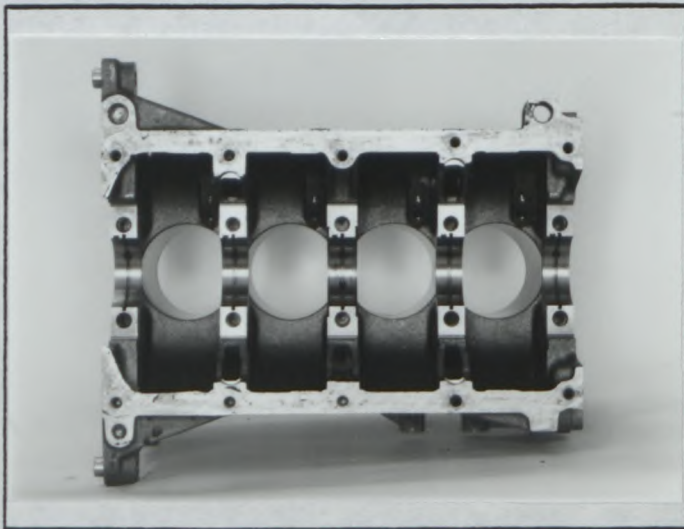

C3) Profil droit du bloc nu
Right hand view of bare block

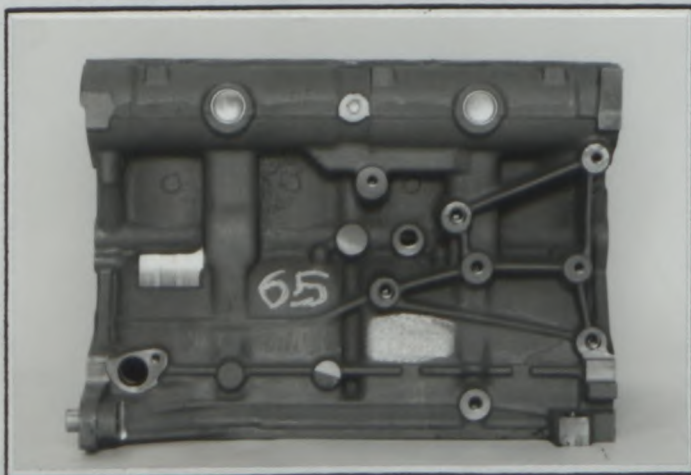

C4) Profil gauche du bloc nu
Left hand view of bare block

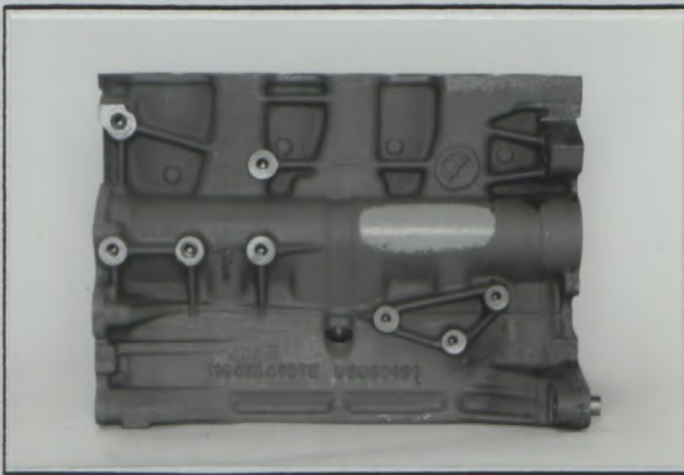

Q FA - FC - 1992 - 030.04 FB.11.94