





Marque BMW Modèle 320i (E36)  
 Make BMW Model 320i (E36)

**C2-0002**

Culasse :  
Cylinder head :

Nombre 1  
Number 1

Système de commande des soupapes Tassenstößel / bucket tappet  
Type of valve operation

Angle entre axe de la soupape d'admission et axe de la soupape d'échappement 38° +/- 10'  
Angle between inlet valve axle and exhaust valve axle

Admission : Nombre de soupapes par cylindre 2  
Inlet : Number of valves per cylinder

Echappement : Nombre de soupapes par cylindre 2  
Exhaust : Number of valves per cylinder

Système de refroidissement : Mode de refroidissement Radiator  
Cooling system : Cooling type

## PHOTOS

Profil droit du moteur complet déposé  
Right hand view of complete dismantled engine

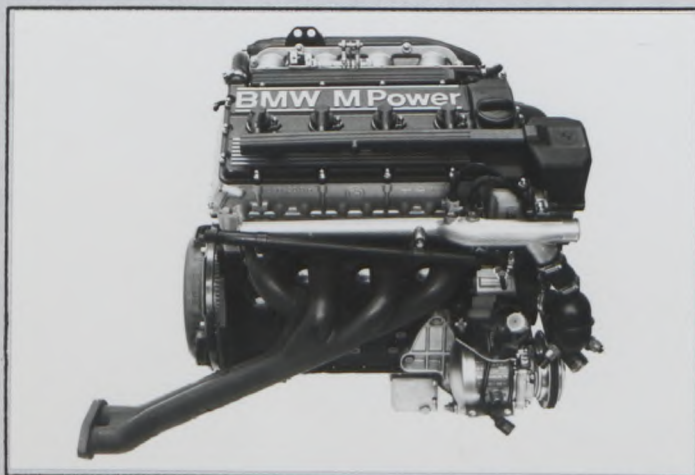

Profil gauche du moteur complet déposé  
Left hand view of complete dismantled engine

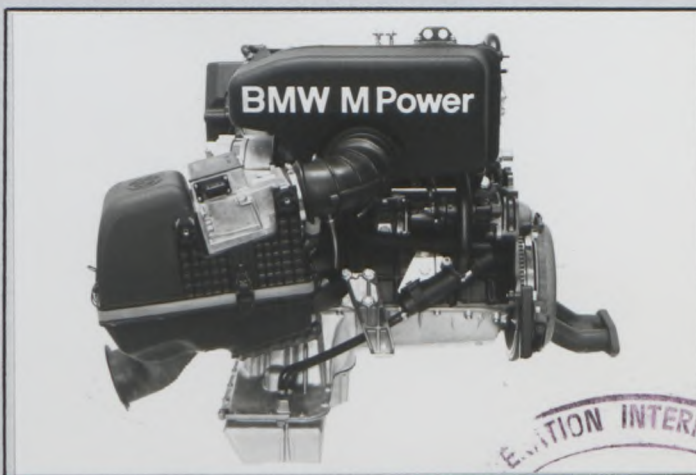

Culasse nue vue de dessus  
Bare cylinder head seen from above

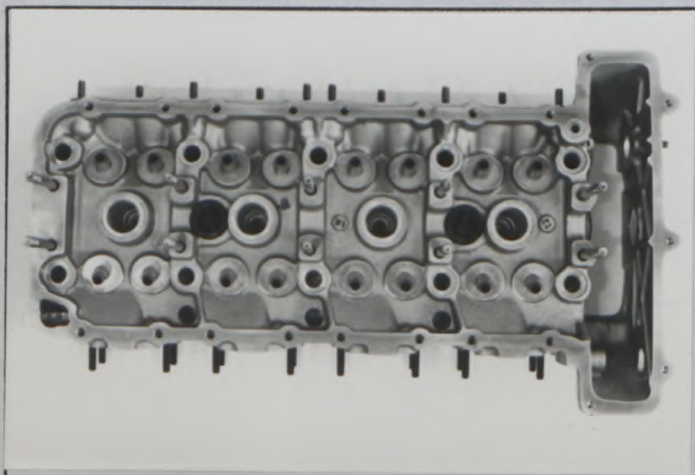

Culasse nue vue de dessous  
Bare cylinder head seen from below

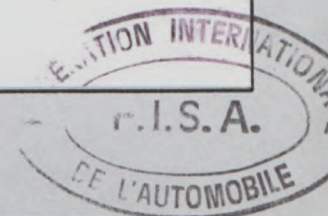
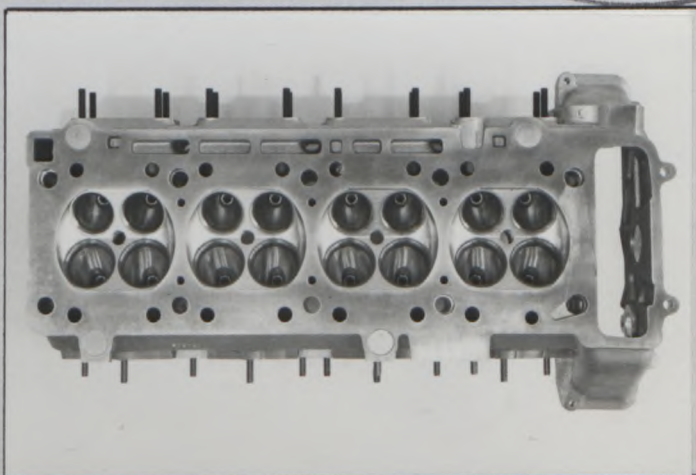



Marque BMW  
Make

Modèle 320i (E36)  
Model

**C2-0002**

Profil droit de culasse nue  
Right hand view of bare cylinder head

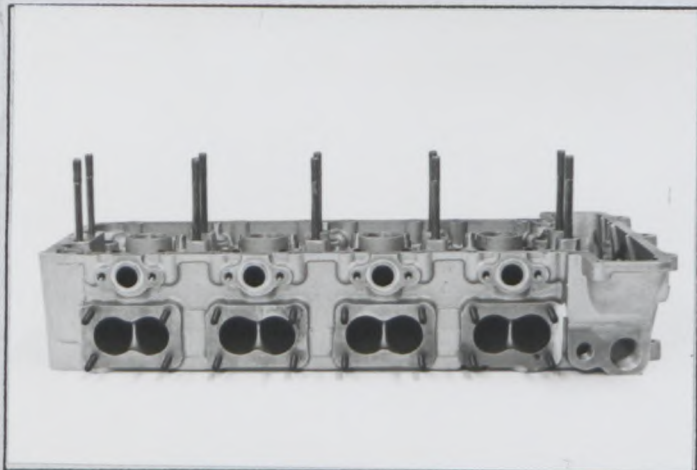

Profil gauche de culasse nue  
Left hand view of bare cylinder head

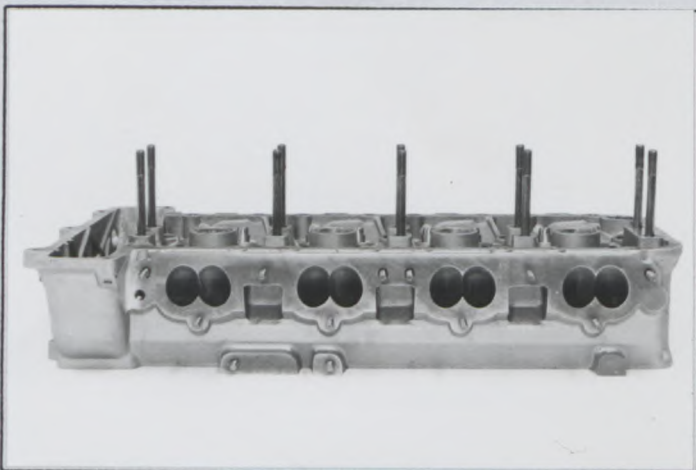

Bloc nu vu de dessus  
Bare block seen from above

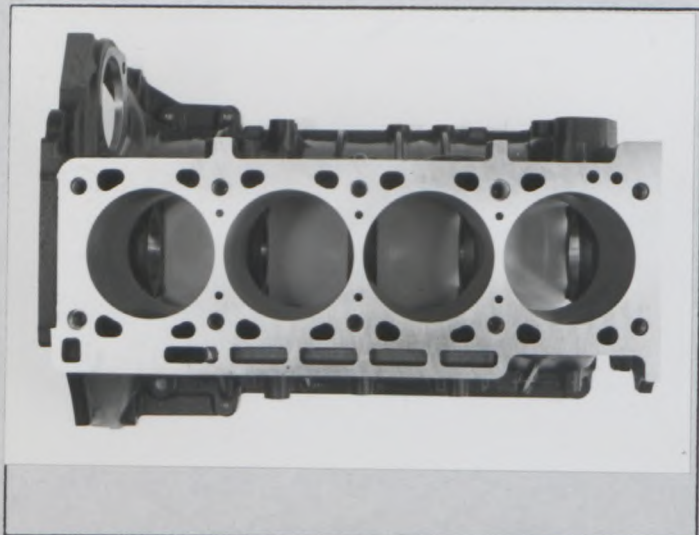

Bloc nu vu de dessous  
Bare block seen from below

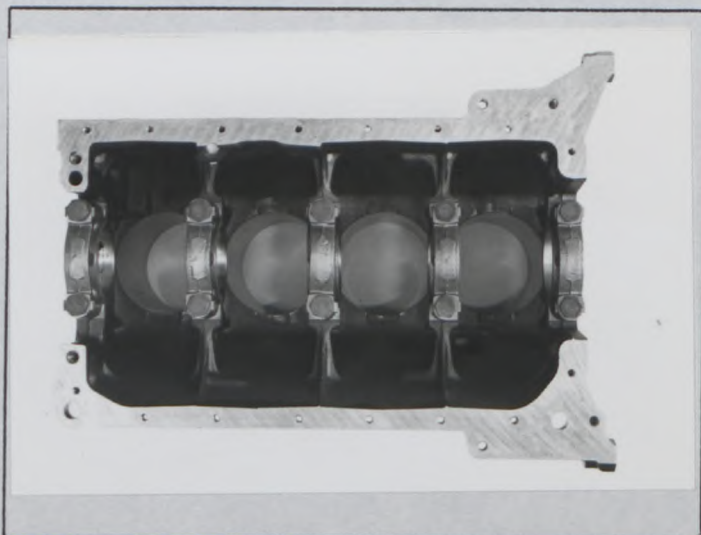

Profil droit du bloc nu  
Right hand view of bare block

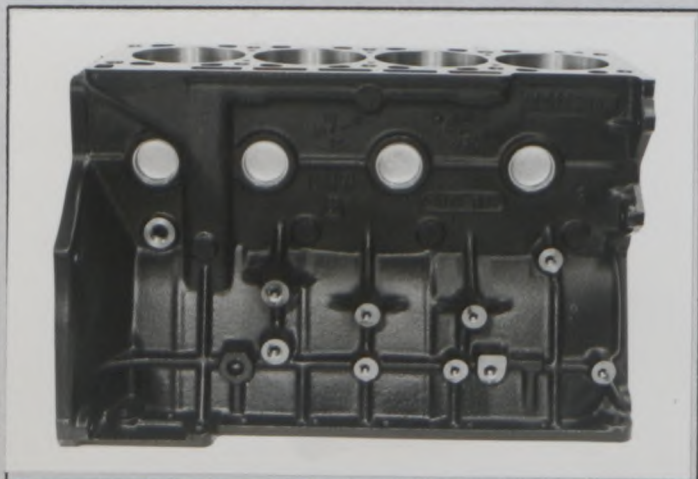

Profil gauche du bloc nu  
Left hand view of bare block

