

# FÉDÉRATION INTERNATIONALE DU SPORT AUTOMOBILE

ONS Oberste Nationale Sportkommission für den Automobilsport in Deutschland GmbH

Homologation Nr.

B - 264 !

Gruppe **A/B**  
Group

## Testblatt nach Anhang J des Internationalen Automobil-Sportgesetzes

Homologation form in accordance with appendix J of the international sporting code

Homologation gültig ab - 1 MAI 1984  
Homologation valid as from

in Gruppe B  
in group

Foto A  
Photo A



Foto B  
Photo B



### 1. Definitionen Definitions

101. Hersteller AUDI NSU AUTO UNION AG  
Manufacturer

102. Handelsbezeichnung — Typ und Modell SPORT QUATTRO S1  
Commercial name(s) — Type and model

103. Gesamthubraum 2134 x 1,4 = 2987,6 ccm  
Cylinder capacity

104. Art der Konstruktion  getrennt, Material des Chassis  
Type of car construction Separate, material of chassis

selbsttragend, Material der Karosserie Metall-Kunststoff-Verbund  
Unitary construction metal-plastics combination

105. Anzahl der Volumina 3  
Number of volumes

106. Anzahl der Sitzplätze 4  
Number of places

Unterschrift und Stempel  
der Nationalen Sporthöheit  
Signature and stamp  
of national sporting authority  

Unterschrift und Stempel  
der FISA  
Signature and stamp  
of FISA  

Marke AUDI  
Make

Modell SPORT QUATTRO SI  
Model

**B-264**  
Homologation Nr. \_\_\_\_\_  
Homologation Nr.

**2. Abmessungen — Gewichte**  
Dimensions — weights

202. Länge über alles 4160 mm ± 1 %  
Overall length

203. Breite über alles 1790 mm ± 1 % Meßpunkt Vorderradmitte/front wheel centre  
Overall width Where measured

204. Karosseriebreite: Width of bodywork:  
a) Vorderradmitte 1790 mm ± 1 %  
At front axle  
b) Hinterradmitte 1780 mm ± 1 %  
At rear axle

206. Radstand: a) Rechts 2204 mm ± 1 % b) Links 2204 mm ± 1 %  
Wheelbase: Right Left:

209. Überhang: a) Vorne 974 mm ± 1 % b) Hinten 982 mm ± 1 %  
Overhang: Front Rear

210. Entfernung „G“ (Lenkrad-hintere Trennwand) 1310 mm ± 1 %  
Distance „G“ (steering wheel — rear bulkhead)

**3. Motor (Für Kreiskolbenmotor siehe Artikel 335 auf Nachtragsblatt)**  
Engine (In case of rotative engine, see Article 335 on complementary form)

301. Einbauort und Lage des Motors vorn in Längsachse, Neigungswinkel 27,5° nach rechts  
Location and position of the engine front in longitudinal axle, angle of declination 27,5° to right

303. Arbeitsverfahren Viertakt/four stroke  
Cycle

304. Aufladung ja / nein; Typ Abgasturboaufladung/exhaust turbo charging  
Supercharging yes/no; Type  
(Bei Aufladung siehe auch Artikel 334 auf Nachtragsblatt)  
(In case of supercharging see also Article 334 on complementary form)

305. Anzahl und Anordnung der Zylinder 5 in Reihe/5 in line  
Number and layout of the cylinders

306. Kühlsystem Flüssigkeitskühlung/liquid cooling  
Cooling system

307. Hubraum: a) Pro Zylinder 426,8 ccm b) Gesamt 2134 x 1.4 = 2987,6 ccm  
Cylinder capacity: a) Unitary Total

c) Maximal zulässiger Hubraum\* 2142 x 1.4 = 2998,8 CCM  
c) Maximum total allowed\*  
\* (Diese Angabe gilt nicht für Gruppe N)  
\* (This indication is not to be considered in Group N)



Marke AUDI  
Make

Modell SPORT QUATTRO S1  
Model

Homologation Nr. B-264  
Homologation Nr.

312. Material des Zylinderblocks Leichtmetall/light alloy  
Cylinder block material

313. Laufbuchsen: a) ja /  nein c) Typ GG, trocken/cast iron, dry  
Sleeves: yes/no Type

314. Bohrung 79,3 mm  
Bore

315. Maximal zulässige Bohrung 79,45 mm  
Maximum bore allowed (Diese Angabe gilt nicht für Gruppe N)  
(This indication is not be considered in Group N)

316. Hub 86,4 mm  
Stroke

318. Pleuel: a) Material Stahl/steel b) Art des Pleuelfußes geteilt/splitted  
Connecting rod: a) Material Big end type

c) Innerer Durchmesser des Pleuelfußes (ohne Lager) 49 mm  $\pm 1\%$   
Interior diameter of the big end (without bearings)

d) Länge zwischen den Achsen 136 mm ( $\pm 0,1$  mm) e) Mindestgewicht 615 g  
Length between the axes Minimum weight

319. Kurbelwelle: a) Herstellungsart einteilig/single piece  
Crankshaft: type of manufacture

b) Material Stahl/steel  
Material

c)  gegossen  geschmiedet d) Anzahl der Kurbelwellen-Hauptlager 6  
moulded stamped Number of bearings

e) Art der Kurbelwellen-Hauptlager Gleitlager/friction bearings  
Type of bearings

f) Durchmesser der Kurbelwellen-Hauptlager 54 mm  $\pm 0,2\%$   
Diameter of bearings

g) Material der Lagerdeckel Guß/cast iron  
Bearing caps material

h) Mindestgewicht der Kurbelwelle (allein) 18600 g  
Minimum weight of the bare crankshaft

320. Schwungrad: a) Material Stahl/steel  
Flywheel: Material

b) Mindestgewicht mit Anlaßzahnkranz 7500 g  
Minimum weight of the flywheel with starter ring

321. Zylinderkopf: a) Anzahl der Zylinderköpfe 1 b) Material Leichtmetall/light alloy  
Cylinderhead: Number of cylinderheads Material

323. Kraftstoffzufuhr durch Vergaser: a) Anzahl der Vergaser  
Fuel feed by carburettor(s): Number of carburettors

b) Typ  
Type c) Marke und Modell  
Marke and model



Marke AUDI  
Make

Modell SPORT QUATTRO S1  
Model

Homologation Nr. B-264  
Homologation Nr.

- d) Anzahl der Gemischdurchlässe je Vergaser \_\_\_\_\_  
Number of mixture passages per carburettor
- e) Maximaler Durchmesser der Gemischöffnung am Vergaserausgang \_\_\_\_\_ mm  
Maximum diameter of the flange hole of the carburettor exit port
- f) Durchmesser des Lufttrichters am engsten Punkt \_\_\_\_\_ mm  
Diameter of the venturi at the narrowest point

324. Kraftstoffzufuhr durch Einspritzung  
Fuel feed by injection: a) Hersteller Bosch  
Manufacturer
- b) Modell des Einspritzsystems LH Jetronic  
Model of injection system
- c) Art der Kraftstoffdosierung  
Kind of fuel measurement  mechanisch  elektronisch  hydraulisch  
mechanical electronic hydraulic
- c1) Kolbenpumpe X ja / X nein  
Piston pump yes/no
- c2) Luftvolumenmessung X ja / X nein  
Measurement of air volume yes/no
- c3) Luftmassenmessung X ja / X nein  
Measurement of air mass yes/no
- c4) Luftgeschwindigkeitsmessung X ja / X nein  
Measurement of air speed yes/no
- c5) Luftdruckmessung X ja / X nein  
Measurement of air pressure yes/no
- Welcher Druck wird zur Messung herangezogen? Saug- bar  
Which pressure is taken for measurement? rohr
- d) Abmessungen der Drosselklappe(n) oder der/des Schieber(s) 70 mm  
Effective dimensions of measure position in the throttle area
- e) Anzahl der effektiven Kraftstoffauslässe 5  
Number of effective fuel outlets
- f) Lage der Einspritzventile  Saugrohr  Zylinderkopf  
Position of injection valves Inlet manifold Cylinderhead
- g) Teile des Einspritzsystems, die zur Kraftstoffdosierung dienen: Luftmassenmesser/air flow meter  
Statement of fuel measuring parts of injection system
- Einspritzventile, Steuergerät/injection valves, control unit

325. Nockenwelle: a) Anzahl 2  
Camshaft: Number
- b) Lage OHC  
Location
- c) Art des Antriebs Zahnriemen/toothed belt  
Driving system
- d) Anzahl der Lager pro Nockenwelle E = 7, A = 6  
Number of bearings for each shaft
- f) Art der Ventilbetätigung Tassenstößel/tappets  
Type of valve operation

326. Steuerung: e) Maximaler Ventilhub  
Timing: Maximum valve lift
- Einlaß 8,5 mm Auslaß 9,0 mm  
Inlet Exhaust
- Mit einem Spiel von 0,25 mm 0,45 mm  
With clearance

327. Einlaß: a) Material des Ansaugkrümmers Leichtmetall/light alloy  
Inlet: Material of the manifold
- b) Anzahl der Ansaugkrümmerelemente 1  
Number of manifold elements
- c) Anzahl der Ventile pro Zylinder 2  
Number of valves per cylinder
- d) Maximaler Durchmesser der Ventile 32,2 mm  
Maximum diameter of the valves
- e) Durchmesser des Ventilschafts 7 mm  
Diameter of the valve stem
- f) Länge des Ventils 104,8 mm  
Length of the valve
- g) Art der Ventilfeeder Schraubenfeder/coil spring  
Type of valve springs



Marke AUDI  
Make

Modell SPORT QUATTRO S1  
Model

Homologation Nr. B-264  
Homologation Nr.

328. Auslaß: a) Material des Auslaßkrümmers Guß/cast iron  
Exhaust: Material of the manifold  
b) Anzahl der Auslaßkrümmergelemente 1  
Number of manifold elements  
c) Anzahl der Ventile pro Zylinder 2  
Number of valves per cylinder  
d) Maximaler Durchmesser der Ventile 28,2 mm  
Maximum diameter of the valves  
e) Durchmesser des Ventilschafts 7 mm  
Diameter of the valve stem  
f) Länge des Ventils 107,5 mm  
Length of the valve  
g) Art der Ventilsfeder Schraubenfeder/coil spring  
Type of valve springs

330. Zündanlage: a) Art Vollelektrische Kennfeldzündung/full electronical ignition  
Ignition system: Type  
b) Anzahl der Kerzen pro Zylinder 1  
Number of plugs per cylinder  
c) Anzahl der Verteiler 1  
Number of distributors

333. Schmiersystem: a) Art Naßsumpf/wet sump  
Lubrication system: Type  
b) Anzahl der Ölpumpen 1  
Number of oil pumps

#### 4. Kraftstoffanlage

Fuel circuit

401. Tank: a) Anzahl 1  
Fuel tank: Number  
b) Lage Kofferraum/luggage compartment  
Location  
c) Material Stahl/steel  
Material  
d) Maximaler Inhalt 90 Liter  
Maximum capacity litre

#### 5. Elektrische Ausrüstung

Electrical equipment

501. Batterie(n): a) Anzahl 1  
Battery(ies): Number

#### 6. Kraftübertragung

Drive

601. Antriebsräder  vorn  hinten  
driving wheels: front rear

602. Kupplung: b) Art der Betätigung Hydraulik/hydraulic  
Clutch: Drive system  
c) Anzahl der Scheiben 1  
Number of plates



Marke AUDI  
 Make

Modell SPORT QUATTRO S1  
 Model

Homologation Nr. B - 264  
 Homologation Nr.

603. Getriebe: a) Lage am Motor angeflanscht/flanged to the engine  
 Gear-box: Location

b) Manuelles Getriebe, Marke Audi  
 „Manual“ make

c) Automatisches Getriebe, Marke -  
 „Automatic“ make

d) Anordnung des Gangschalthebels Mitteltunnel/center tunnel  
 Location of the gear lever

e) Übersetzungen  
 Ratios

	Handschtaltung <small>Manual</small>			Automatik <small>Automatic</small>			Zusätzl. Getriebe <small>Additional G.B</small>		
	Über- setzungen ratio	Anzahl der Zähne number of teeth	synchro.	Über- setzungen ratio	Anzahl der Zähne number of teeth	synchro.	Über- setzungen ratio	Anzahl der Zähne number of teeth	synchro.
1	3,500	28:8	X				3,111	28:9	X
2	2,083	25:12	X				2,273	25:11	X
3	1,368	26:19	X				1,706	29:17	X
4	0,9615	25:26	X				1,318	29:22	X
5	0,8214	23:28	X				1,125	27:24	X
Rück- wärts R	3,500	42:12					3,500	42:12	
Kon- stante Con- stant									

f) Schalt-Schema  
 Gear change gate

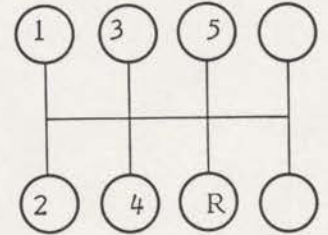
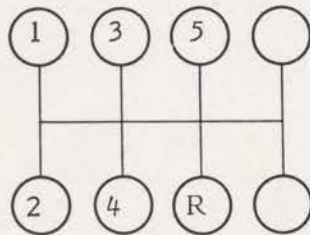

604. Schnellgang: a) Art \_\_\_\_\_  
 Overdrive: Type

b) Übersetzung \_\_\_\_\_  
 Ratio

c) Anzahl der Zähne \_\_\_\_\_  
 Number of teeth

d) Vorwärtsgänge, zu denen der Schnellgang zugeschaltet werden kann \_\_\_\_\_  
 Usuable with the following gears



Marke AUDI  
Make

Modell SPORT QUATTRO S1  
Model

Homologation Nr. \_\_\_\_\_  
Homologation Nr.

605. Antriebsachse  
Final drive

	Vorn Front	Hinten Rear
a) Art des Achsantriebs Type of final drive	Hypoid-Kegeltrieb	Hypoid-Kegeltrieb
b) Übersetzungsverhältnis Ratio	3,875	3,875
c) Anzahl der Zähne Number of teeth	31 : 8	31 : 8
d) Art des Sperrdifferentials (wenn vorhanden) Type of differential limitation (if provided)	./.	begrenzter Schlupf, schaltbar limited slip, switchable

e) Übersetzungsverhältnis des Verteilergetriebes 1 : 1 oder blockiert / 1 : 1 or locked  
Ratio of the transfer box

606. Art der Gelenkwelle 4 Halbwellen homokinetisch und 1 geteilte Kardanwelle  
Type of transmission shaft 4 drive shafts homocinetic and 1 propshaft, splitted

7. Radaufhängung  
Suspension

701. Art der Radaufhängung: a) Vorn Mc Pherson Federbein/Mc Pherson single wishbone  
Type of suspension Front  
b) Hinten Mc Pherson Federbein/Mc Pherson single wishbone  
Rear

702. Schraubenfedern: Vorn: ja / ~~nein~~ Hinten: ja / ~~nein~~  
Helicoidal springs: Front: yes/no Rear: yes/no

703. Blattfedern: Vorn: ~~ja~~ / nein Hinten: ~~ja~~ / nein  
Leaf springs: Front: yes/no Rear: yes/no

704. Drehstab: Vorn: ~~ja~~ / nein Hinten: ~~ja~~ / nein  
Torsion bar: Front: yes/no Rear: yes/no

705. Andere Arten der Radaufhängung: s. Bild / Zeichnung auf Seite 15  
Other type of suspension: See photo or drawing on page 15



Marke AUDI  
Make

Modell SPORT QUATTRO S1  
Model

Homologation Nr. B-264  
Homologation Nr.

707. Stoßdämpfer  
Shock absorbers

- a) Anzahl je Rad  
Number per wheel
- b) Art  
Type
- c) Funktionsprinzip  
Working principle

Vorn Front	Hinten Rear
1	1
Teleskop/telescopic	Teleskop/telescopic
Hydraulisch/hydraulic	Hydraulisch/hydraulic

8. Fahrwerk  
Running gear

801. Räder:  
Wheels: a) Durchmesser Vorn 15 " / 381 mm Hinten 15 " / 381 mm

803. Bremsen:  
Brakes: a) Bremssystem Zweikreisbremssystem/dual circuit brake system

b) Anzahl der Hauptzylinder 1 b1) Bohrung 23,81 / 23,81 mm

c) Servo-Bremse ja / ~~XXX~~ c1) Marke und Art VW/Audi Hydraulisch/hydraulic

d) Bremskraftregler ja / ~~XXX~~ d1) Lage am Hauptzylinder/at main cylinder

e) Anzahl der Zylinder je Rad  
Number of cylinders per wheel

1) Bohrung 1,625" = 41,28 mm 1,25" = 31,75 mm

f) Trommelbremsen  
Drum brakes

1) Innendurchmesser \_\_\_\_\_ mm (± 1,5 mm) \_\_\_\_\_ mm (± 1,5 mm)

2) Anzahl der Bremsbacken je Rad \_\_\_\_\_ \_\_\_\_\_

3) Bremsfläche \_\_\_\_\_ qcm \_\_\_\_\_ qcm

4) Breite der Bremsbeläge \_\_\_\_\_ mm \_\_\_\_\_ mm

g) Scheibenbremsen  
Disc brakes

1) Anzahl der Bremsbeläge je Rad 2 4

2) Anzahl der Sättel je Rad 1 2

Vorn Front	Hinten Rear
4	4
<u>1,625" = 41,28</u> mm	<u>1,25" = 31,75</u> mm
<u>_____</u> mm (± 1,5 mm)	<u>_____</u> mm (± 1,5 mm)
<u>_____</u>	<u>_____</u>
<u>_____</u> qcm	<u>_____</u> qcm
<u>_____</u> mm	<u>_____</u> mm
2	4
<u>_____</u>	<u>_____</u>
1	2
<u>_____</u>	<u>_____</u>





AUDI

SPORT QUATTRO SI

B-264

Marke  
Make

Modell  
Model

Homologation Nr.  
Homologation Nr.

- 3) Material der Bremssättel  
Caliper material
- 4) Maximale Dicke der Scheibe  
Maximum disc thickness
- 5) Außendurchmesser der Scheibe  
Exterior diameter of the disc
- 6) Außendurchmesser der Belagfläche  
Exterior diameter of the shoes rubbing surface
- 7) Innendurchmesser der Belagfläche  
Interior diameter of the shoes rubbing surface
- 8) Länge der Beläge über Alles  
Overall length of the shoes
- 9) Belüftete Scheiben  
Ventilated disc
- 10) Bremsfläche je Rad  
Braking surface per wheel

Vorn Front	Hinten Rear
Leichtmetall	Leichtmetall
28 mm	28 mm
295 mm (± 1 mm)	295 mm (± 1 mm)
295 mm	295 mm
195 mm	195 mm
125 mm	125 mm
ja / nein yes/no XXX	ja / nein yes/no XXX
770 qcm	770 qcm

h) Feststellbremse  
Parking brake

1) Betätigungssystem  
Command system mechanisch durch Seil  
mechanical by cable

2) Lage des Bremshebels auf Mittelunnel/center  
Location of the lever tunnel

3) Wirkung auf die Räder XXX  
On which wheels Front Hinten  
Rear

804. Lenkung:

a) Art: Zahnstangenlenkung  
Type

b) Übersetzungsverhältnis 22,4 : 1  
Ratio

c) Lenkhilfe ja / nein  
Power assisted XXX  
yes/no

9. Karosserie  
Bodywork

901. Innen:  
Interior:

a) Belüftung ja / nein  
Ventilation XXX  
yes/no

b) Heizung ja / nein  
Heating XXX  
yes/no

f) Sonderausstattung Schiebedach ja / nein  
Sun roof optional XXX  
yes/no

1) Art \_\_\_\_\_  
Type

2) Betätigungssystem \_\_\_\_\_  
Command system

g) Öffnungssystem der Seitenscheiben:  
Opening system for the side windows

Vorn mechanisch/mechanic  
Front  
Hinten /  
Rear

902. Außen:  
Exterior:

a) Anzahl der Türen 2  
Number of doors

b) Heckklappe ja / nein  
Rear tailgate XXX  
yes/no

c) Material der Türen \_\_\_\_\_  
Door material

Vorn Stahlblech  
Front  
Hinten \_\_\_\_\_  
Rear



Marke AUDI  
Make

Modell SPORT QUATTRO S1  
Model

Homologation Nr. B-264  
Homologation Nr.

- d) Material der Fronthaube Kunststoff/plastics  
Front bonnet material
- e) Material der Heckhaube/-klappe Kunststoff/plastics  
Rear bonnet / tailgate material
- f) Material der Karosserie Metall-Kunststoffverbund/metal-plastics combination  
Bodywork material
- g) Material der Windschutzscheibe Verbundglas/laminated glass  
Windscreen material
- h) Material der Heckscheibe Sicherheitsglas/safety glass  
Rear window material
- i) Material der hinteren Seitenscheiben Sicherheitsglas/safety glass  
Rear quarter lights material
- k) Material der Seitenscheiben  
Side window material  
Vorn Sicherheitsglas/safety glass  
front  
Hinten Sicherheitsglas/safety glass  
rear
- l) Material der vorderen Stoßstange Kunststoff/plastics  
Material of the front bumper
- m) Material der hinteren Stoßstange Kunststoff/plastics  
Material of the rear bumper

**Zusätzliche Informationen**  
Complementary informations

321e) Winkel zwischen den Achsen der Einlaß- und Auslaßventile 25°  
Angle between the axis of the inlet- and outletvalve 25°

605b) auch/also 32/7 ; 34/7

605c) auch/also 4,571 ; 4,857

701) In der Karosserie sind unterschiedliche Aufhängungspunkte für die vordere Radaufhängung vorgesehen/the bodyshell provides different mounting points for the front suspension.



Draufsicht/view from above

803) mit Anti Blockier-System/with anti-blockage-system



Verstelleinrichtung für Aufbau vorn und hinten, Toleranzausgleich wgen kleiner Produktions-Stückzahl H. max. = 26 mm  
Adjusting device for body mounting front and rear, tolerance balancing due to low production number H. max. = 26 mm



Getriebegehäuse für 2. Radsatz  
gear box housing for second set of ratios

Foto S1





Marke AUDI  
Make

Modell SPORT QUATTRO S1  
Model

Homologation Nr. \_\_\_\_\_  
Homologation Nr.

**Fotos**  
Photos

**Motor**  
Engine

C) Rechte Seitenansicht Motor (ausgebaut)  
Right hand view of dismantled engine



D) Linke Seitenansicht Motor (ausgebaut)  
Left hand view of dismantled engine



E) Motor im Motorraum  
Engine in its compartment



F) Zylinderkopf allein  
Bare cylinderhead

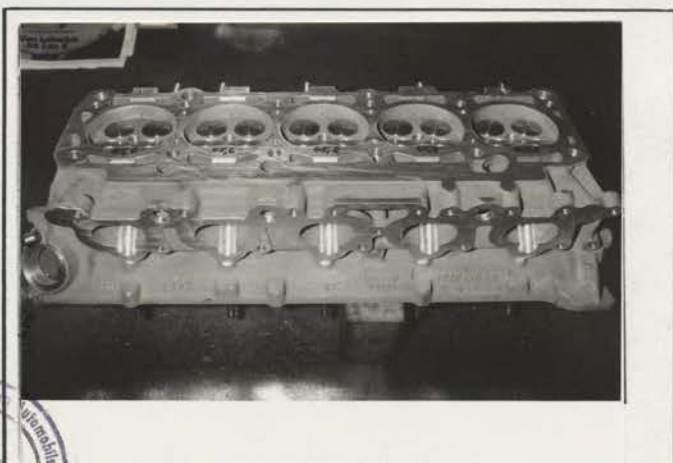

Marke AUDI  
Make

Modell SPORT QUATTRO S1  
Model

Homologation Nr.  
Homologation Nr.

G) Verbrennungsraum  
Combustion chamber

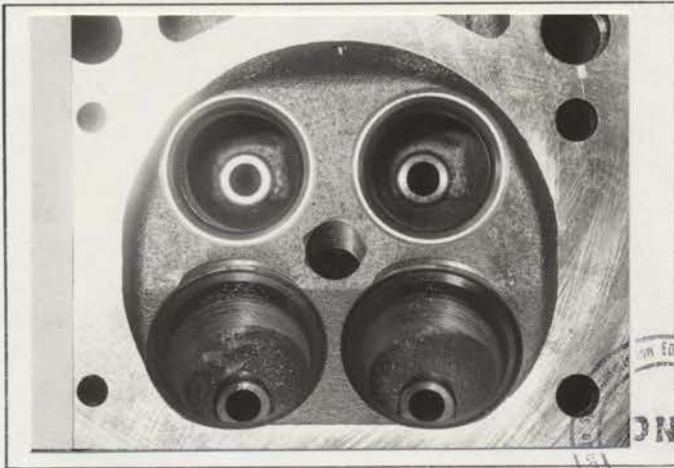

H) Vergaser oder Einspritzsystem  
Carburetor(s) or injection system

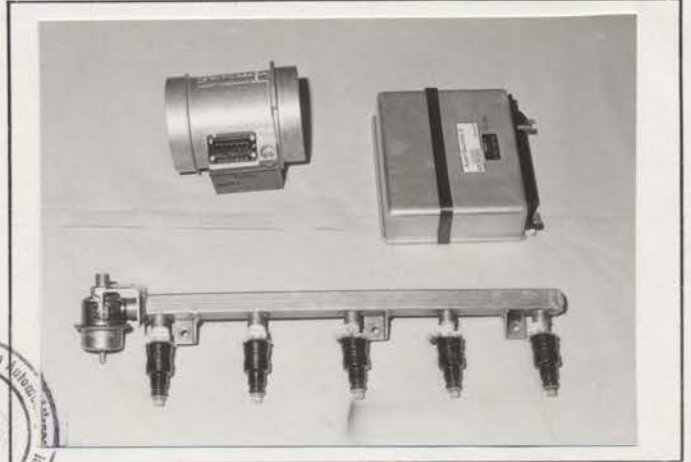

I) Einlaßkrümmer  
Inlet manifold



J) Auspuffkrümmer  
Exhaust manifold



Ø 57,5 mm

Getriebe  
Transmission

S) Getriebegehäuse und Kupplungsglocke  
Gearbox casing and clutch bellhousing



Marke AUDI  
Make

Modell SPORT QUATTRO S1  
Model

Homologation Nr. \_\_\_\_\_  
Homologation Nr.

**Radaufhängung**  
Suspension

T) Vorderachse vollständig ausgebaut  
Complete dismantled front running gear

U) Hinterachse vollständig ausgebaut  
Complete dismantled rear running gear

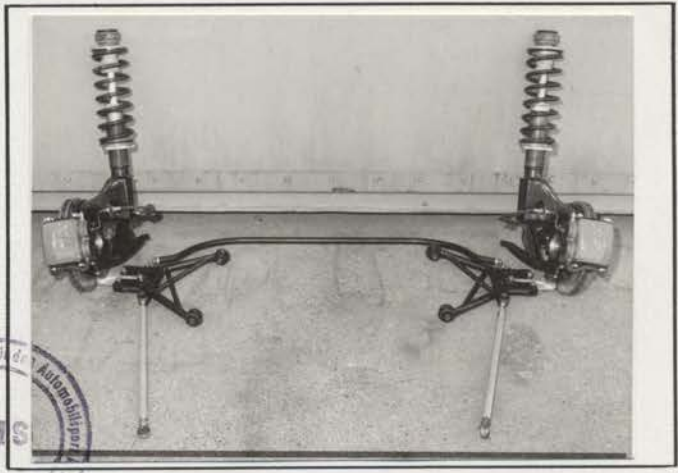
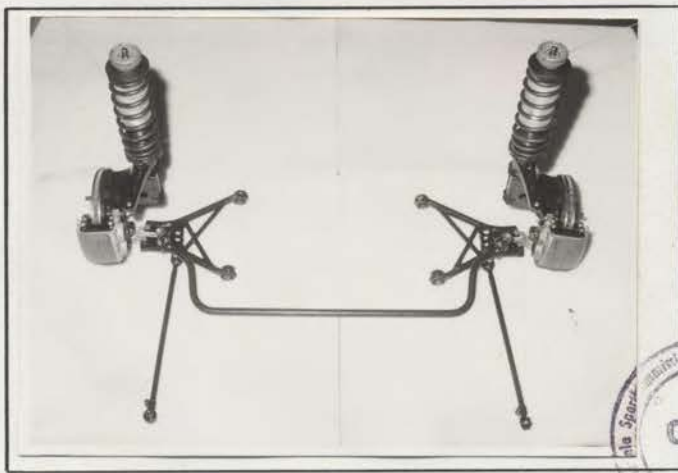

**Fahrwerk**  
Running gear

V) Bremsen vorn  
Front brakes

W) Bremsen hinten  
Rear brakes

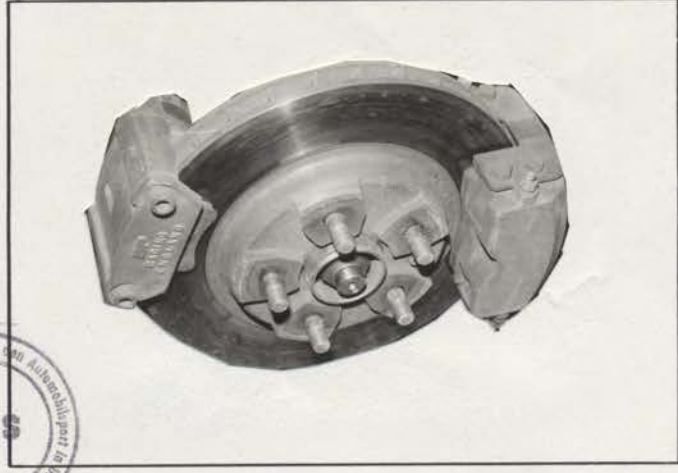
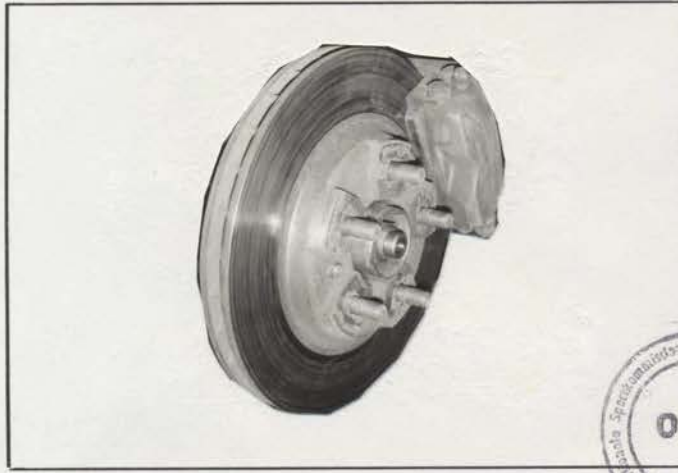

**Karosserie**  
Bodywork

X) Armaturenbrett  
Dashboard

Y) Schiebedach  
Sunroof



Zeichnungen  
Drawings

Motor  
Engine

I. Einlaßöffnungen im Ansaugkrümmer  
Cylinderhead inlet ports, manifold side

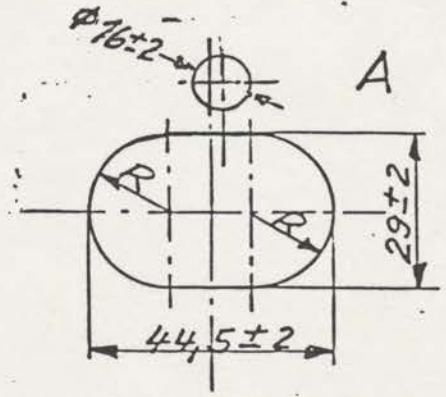
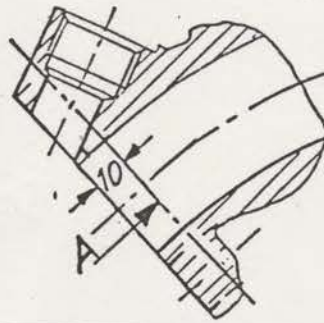

II. Einlaßöffnungen im Zylinderkopf  
Inlet manifold ports, cylinderhead side

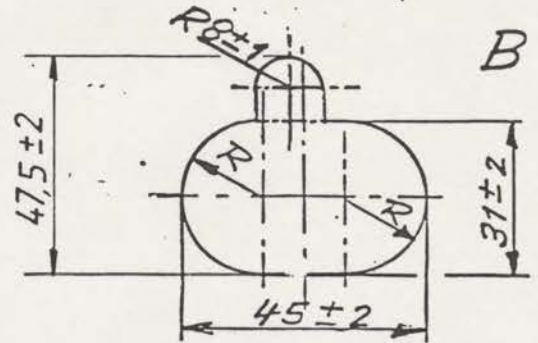
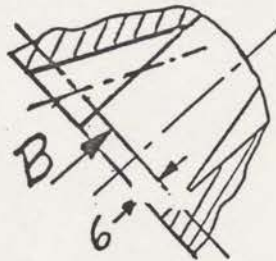

III. Auslaßöffnungen im Auspuffkrümmer  
Cylinderhead exhaust ports, manifold side

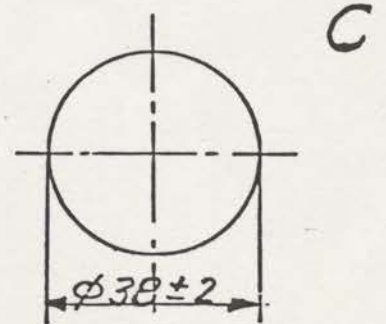
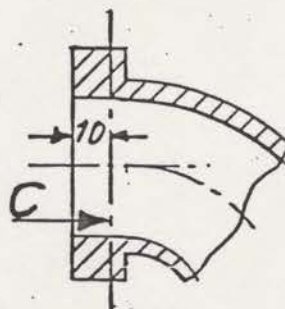

IV. Auslaßöffnungen im Zylinderkopf  
Exhaust manifold ports, cylinderhead side

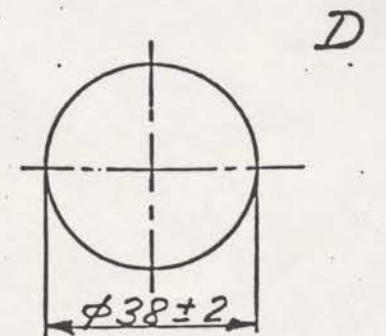
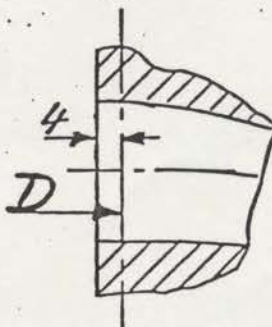



B - 264

Marke AUDI  
Make

Modell SPORT QUATTRO S1  
Model

Homologation Nr. \_\_\_\_\_  
Homologation Nr.

**Radaufhängung**  
Suspension

XV. System der Radaufhängung gem. Art. 705 oder anstelle der Fotos T und U  
Suspension system according to article 705 or replacing photos T and U



# FÉDÉRATION INTERNATIONALE DU SPORT AUTOMOBILE

ONS Oberste Nationale Sportkommission für den Automobilsport in Deutschland GmbH

Homologation Nr.

**B - 264**

Gruppe **A/B**  
Group

Marke AUDI  
Make

Modell QUATTRO SPORT S1  
Model

Innenabmessungen gem. Homologationsbestimmungen  
Interior dimensions as defined by the Homologation Regulations.

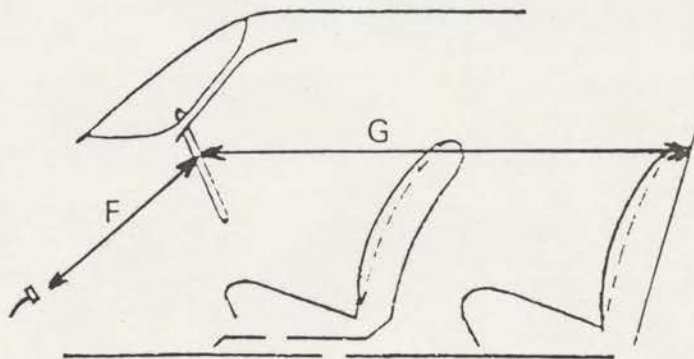
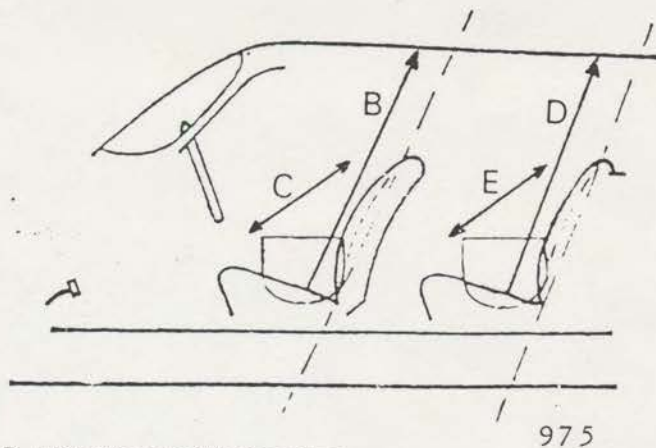

B Höhe über den Vordersitzen 975 mm  
Height above front seats

C Breite über den Vordersitzen 1364 mm  
Width at front seats

D Höhe über den Rücksitzen 963 mm  
Height above rear seats

E Breite über den Rücksitzen 1360 mm  
Width at rear seats

F Abstand Lenkrad — Bremspedal 661 mm  
Steering wheel — brake pedal

G Abstand Lenkrad — Hintere Trennwand 1310 mm  
Steering wheel — rear bulkhead

H = F + G = 1971 mm





# FEDERATION INTERNATIONALE DU SPORT AUTOMOBILE

Homologation N°

**B - 264**

Groupe **A/B**  
Group

FICHE D'HOMOLOGATION ADDITIONNELLE POUR MOTEURS SURALIMENTÉS PAR TURBOCOMPRESSEUR(S)  
ADDITIONAL HOMOLOGATION FORM FOR TURBO CHARGED ENGINES

Véhicule : Constructeur AUDI NSU AUTO UNION AG      Modèle et type SPORT quattro S1  
Vehicle : Manufacturer AUDI NSU AUTO UNION AG      Model and type SPORT quattro S1

Homologation valable à partir du \_\_\_\_\_ en groupe B  
Homologation valid as from \_\_\_\_\_ in group B

334. Suralimentation Turbocharging  
a) Marque et type du turbo compresseur KKK K27  
Make and type of the turbocharger  
b) Carter de turbine : Turbine housing :  
b1) Nombre d'entrées des gaz d'échappement 1  
Number of exhaust gas entries  
b2) Matériau Cr Ni Si-Legierung -alloy  
Material

c) Roue de turbine : Turbine wheel :  
c1) Matériau Nickellegierung / Ni-alloy  
Material  
c2) Nombre d'aubes 12  
Number of blades  
c3) Hauteur(s) d'une aube 11,5  
Height(s) of blade \_\_\_\_\_ mm

c4) Préciser les cotes A,B,C, selon le schéma suivant :  
Indicate the dimensions A, B, C, according to the following sketch :  
A = 64 mm  
B = 11,5 mm  
C = 76,2 mm

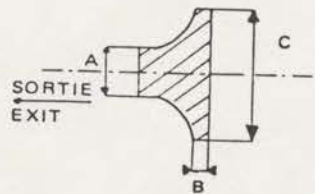

d) Carter de compression : Impeller housing :  
d1) Nombre d'entrée d'air (mélange) 1  
Number of air entries (gas)  
d2) Matériau Leichtmetallegerung / light alloy  
Material

e) Roue de compression Impeller wheel :  
e2) Nombre d'aubes 12  
Number of blades  
e3) Hauteur(s) d'une aube 7,1  
Height(s) of blade \_\_\_\_\_ mm

e4) Préciser les cotes A, B, C selon le schéma suivant :  
Indicate the dimensions A, B, C, according to the following sketch,  
A = 48,2 mm  
B = 7,1 mm  
C = 76 mm

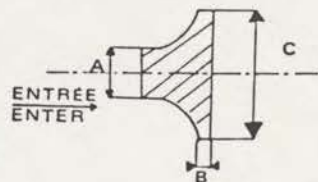

Marque AUDI  
Make

Modèle Sport quattro S 1 N° Homol.  
Model

B-264

f) Régulation de la pression :  
Pressure regulation :

f1) Type de régulation de la pression :  by-pass  soupape de décharge  autre cas  
Type of pressure adjustment :  by-pass  relief valve  other case

f2) Préciser le type de la soupape et son contrôle wastegate  
Indicate the type of the valve and its control Abblasventil pneumatisch/pneumatic

g) Système d'échappement :  
Exhaust system :

Dimensions intérieures de l'éventuel tuyau d'échappement entre le collecteur d'échappement et le turbocompresseur (dessin)  
Internal dimensions of the eventual exhaust pipes between exhaust manifold and turbocharger (sketch)

h) Refroidissement de l'air d'admission : oui/~~non~~  
Cooling of intake air : yes/~~no~~



### PHOTOS

k) Vue de dessus du turbo compresseur  
Plan view of turbocharger



l) Vue de face du turbo compresseur  
Front view of turbocharger

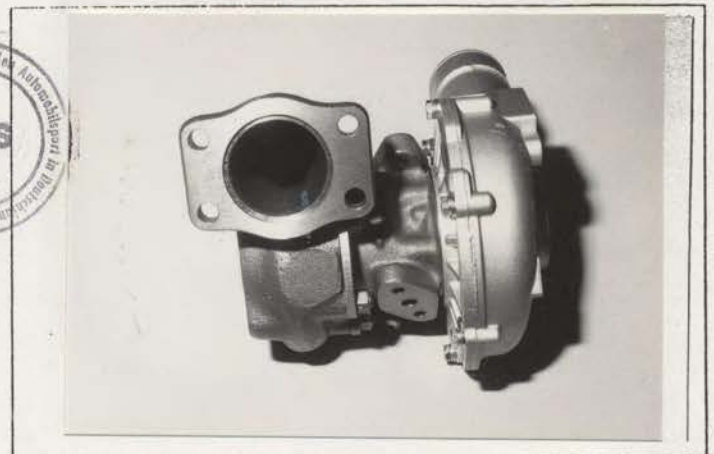

M) Vue de côté du turbocompresseur  
Side view of turbocharger



N) Carter de turbine du turbocompresseur  
Turbine housing of turbocharger



O) Soupape et montage du by-pass du turbocompresseur  
Valve and by-pass installation of turbocharger

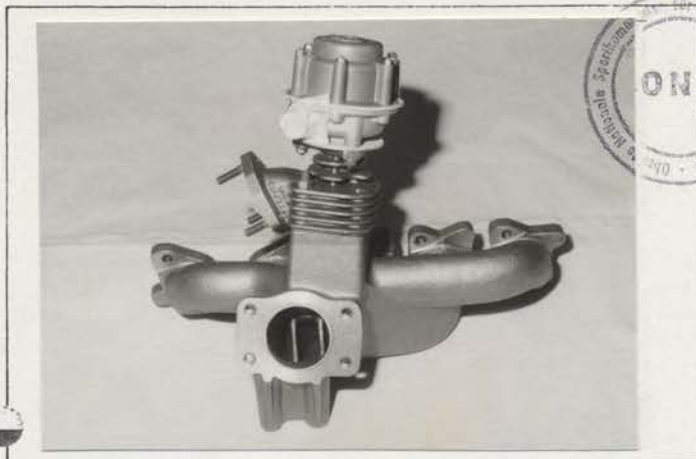

P) Eventuel échappement entre le collecteur d'échappement et le turbocompresseur.  
Eventual exhaust pipes between the exhaust manifold and the turbocharger.

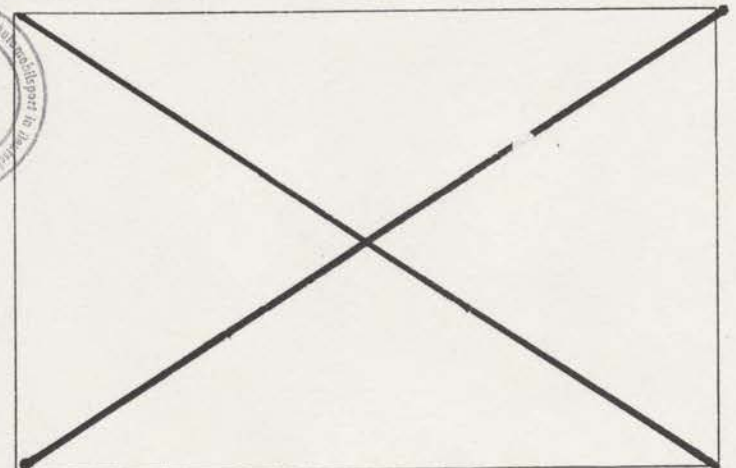

Q) Carter de compression du turbocompresseur  
Impeller housing of turbocharger

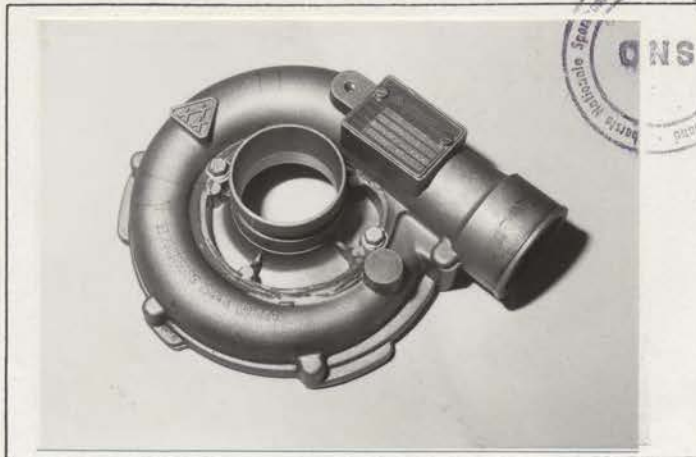

DESSINS / DRAWINGS

V) Entrée des gaz d'échappement dans le carter de turbine du turbocompresseur  
 Exhaust gas entry in the turbine housing of turbocharger.

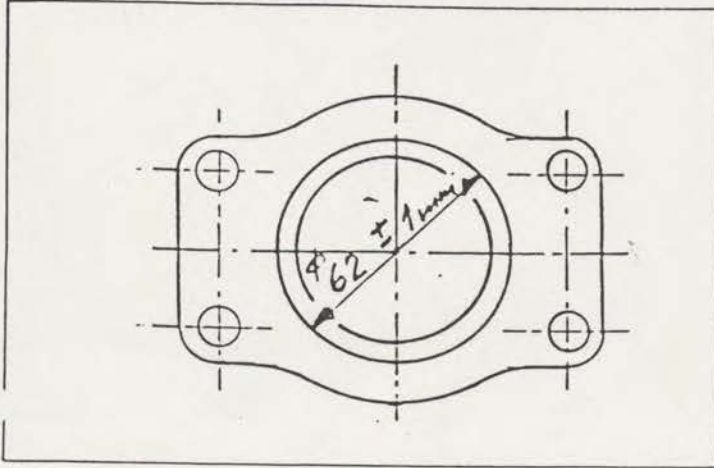

VI) Sortie des gaz d'échappement du carter de turbine de turbocompresseur.  
 Exhaust gas exit of the turbine housing of turbocharger.

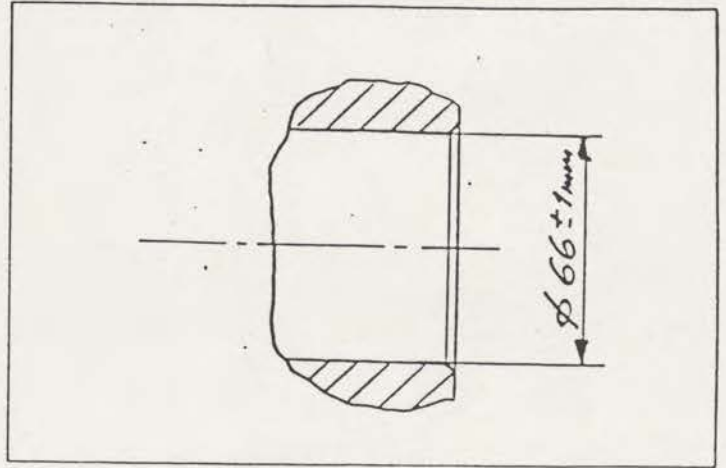

VII) Entrée de l'air (mélange) dans le carter de compression du turbocompresseur.  
 Air (gas) entry in the impeller housing of the turbocharger

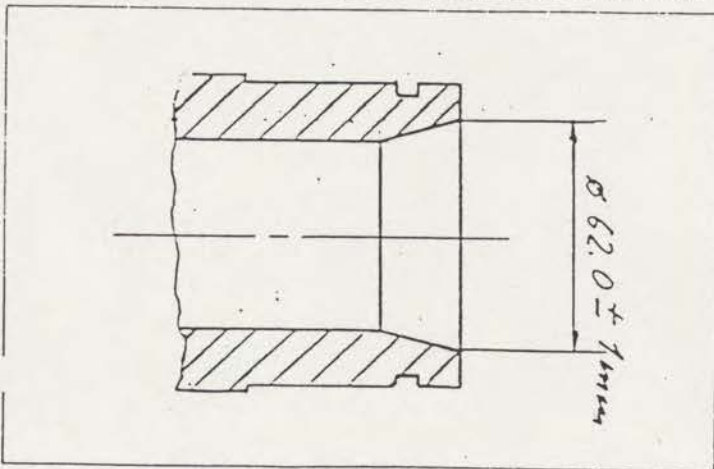

VIII) Sortie de l'air (mélange) du carter de compression du turbocompresseur.  
 Air (gas) exit of the impeller housing of the turbocharger.

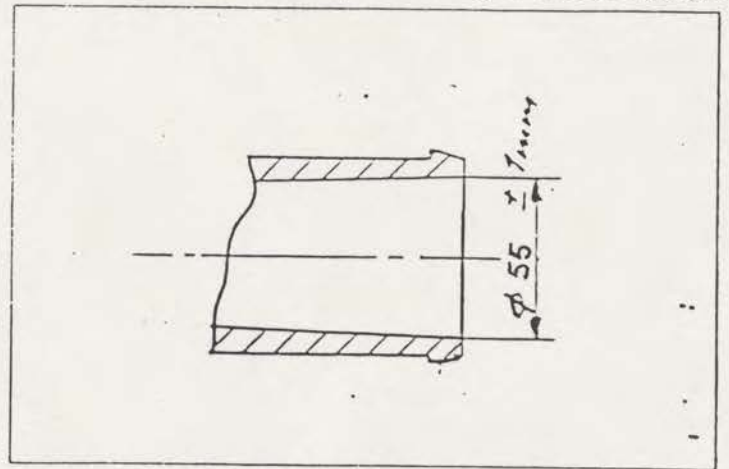

IX. Dispositif réglant la pression de suralimentation  
 Device regulating the turbocharging pressure.

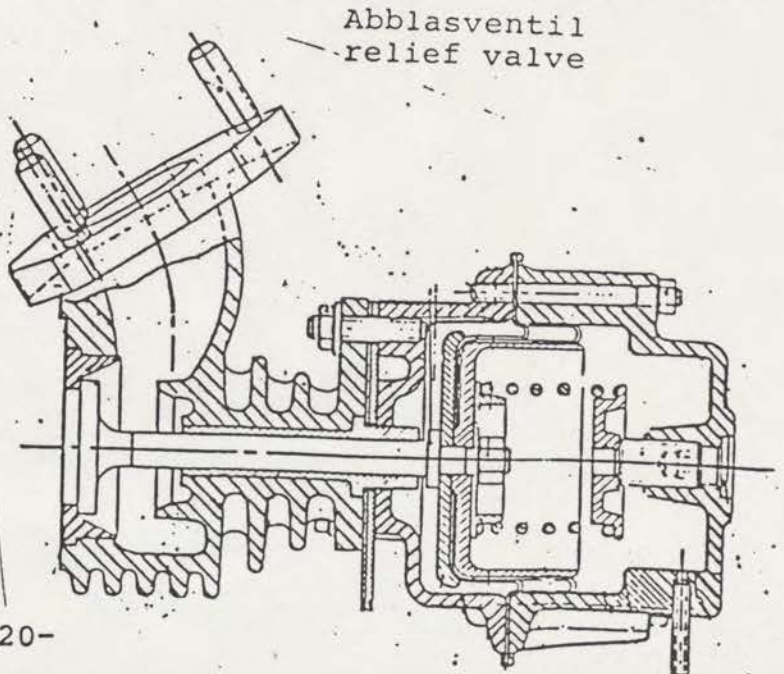



# FEDERATION INTERNATIONALE DU SPORT AUTOMOBILE

Homologation N°

**B - 264**

Extension N°

**01 / 01 VO**

FICHE D'EXTENSION A L'HOMOLOGATION OFFICIELLE FISA  
FORM OF EXTENSION TO THE OFFICIAL FISA HOMOLOGATION

VO Variante option / Option variant

Homologation valable dès le **01 MAI 1984** en groupe **B**  
Homologation valid as from \_\_\_\_\_ in group \_\_\_\_\_

Constructeur de la voiture **AUDI NSU AUTO UNION AG** Modèle et type **SPORT QUATTRO S1**  
Manufacturer of the car \_\_\_\_\_ Model and type \_\_\_\_\_

## ARCEAU / CAGE DE SECURITE

## ROLLBAR / ROLLCAGE

Arceau principal

Entretoise  
longitudinale/diagonale

Arceau avant

Main rollbar

Longitudinal/diagonal  
strut

Front rollbar

Fabricant de l'arceau Rollbar manufacturer	Winfried Matter GmbH, Industriegebiet, 7523 Graben-Neudorf					
Matériau Material	Al Zn Mg1		Al ZN Mg1		Al Zn Mg1	
Diamètre extérieur Exterior diameter	40	mm	40	mm	40	mm
Epaisseur de paroi Wall thickness	3	mm	3	mm	3	mm
Limite élastique Elastic limit	30,0	kg/mm <sup>2</sup>	30,0	kg/mm <sup>2</sup>	30,0	kg/mm <sup>2</sup>
Résistance à la traction Tensile strength	36	kg/mm <sup>2</sup>	36	kg/mm <sup>2</sup>	36	kg/mm <sup>2</sup>
Poids total y-compris les fixations Total weight including fixings	25				kg	

Arceau/cage complet(e) hors de la voiture  
Complete rollbar/rollcage outside the car

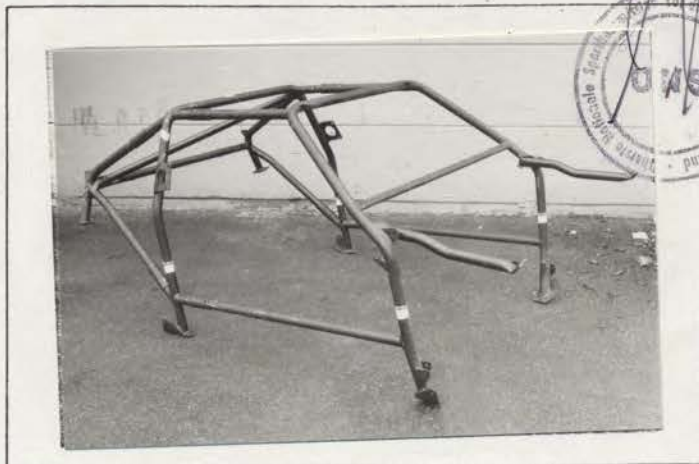

Nous attestons que le présent arceau / la présente cage de sécurité répond aux dispositions de l'Annexe J de la FIA, en particulier en ce qui concerne ses implantations, ses connexions et ses résistances aux contraintes.

We certify that the present rollbar/rollcage complies with the conditions of the FIA Appendix J, in particular with regard to its attachments, its connections and its stress resistances.

Signature du représentant du constructeur du véhicule  
Signature of the car manufacturer representative



Marque AUDI  
Make \_\_\_\_\_

Modèle SPORT QUATTRO S1  
Model \_\_\_\_\_

N° Homol. B-264

01/01V0

PHOTOS OU DESSINS DES FIXATIONS SUR LA COQUE :  
PHOTOS OR DRAWINGS OF THE ATTACHMENTS ON THE BODY :

N° Ext. \_\_\_\_\_





# FÉDÉRATION INTERNATIONALE DU SPORT AUTOMOBILE

ONS Oberste Nationale Sportkommission für den Automobilsport in Deutschland GmbH

Homologation Nr.

**B - 264**

Nachtrag Nr.  
Extension Nr.

**02 / 02 VO**

## Nachtrag zum offiziellen Testblatt der FISA

Form of extension to the official FISA Homologation

ET Normale Weiterentwicklung des Typs; ab Fahrgestell -Nr.: \_\_\_\_\_  
Normal evolution of the type, as from chassis number

VF Liefervariante  
Delivery variant

VO Ausstattungsvariante  
Equipment variant

ER Einrichtung  
Equipment

**01 MAI 1984**

Homologation gültig ab: \_\_\_\_\_ in Gruppe: B  
Homologation valid from: \_\_\_\_\_ Group:

Hersteller: Audi NSU Auto Union AG Modell und Typ: Sport quattro S1  
Manufacturer: \_\_\_\_\_ Model and type:

Seite des Nachtrags Page of addendum	Nr. No.	Beschreibung Description	
5	333	Schmiersystem: Trockensumpfschmierung lubrication system: dry sump lubrication	Foto 1 Photo 1
	401	Tank:	
	401 c	Material: Kunststoff mit Feuerschutzwand material: plastics with fire protection	Foto 2 Photo 2
	401 d	Maximaler Inhalt: 120 Ltr. maximum capacity: 120 Ltr.	Foto 3 Photo 3
7	606	Verstärkte Gelenkwelle vorn + hinten reinforced drive shaft front + rear	Foto 4 Photo 4
	701 a, b	Verstärkter Querlenker vorn + hinten Material: Stahl reinforced wishbone front + rear material: steel	Foto 5 Photo 5
	701 a, b	Verstärkter Querlenker vorn + hinten Material: Leichtmetall reinforced wishbone front and rear material: light alloy	Foto 5 Photo 5

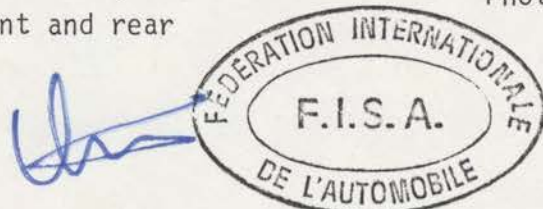

Marke Audi  
Make

Modell Sport quattro S1  
Model

Homologations Nr. B-264  
Homologation Nr.

Fotos  
Photos

Nachtrag Nr. 02/02 V0  
Ext. Nr.

1



2



3



4



5

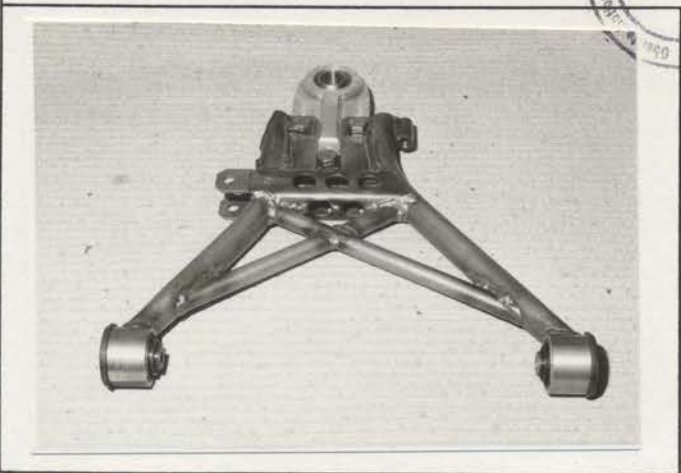

Marke Audi  
Make

Modell Sport quattro S1  
Model

Homologations Nr. B-264  
Homologation Nr.

**02 / 02 VO**

Nachtrag Nr. \_\_\_\_\_  
Ext. Nr.

Seite od. Nachtrag <small>Page or ext.</small>	Artikel <small>-</small>	Beschreibung <small>Description</small>	
7	701 a,b	Federbein verstärkt vorn mit unterschiedlichen Bolzen zur Aufnahme des Querlenkers und zum Ausgleich der Anlenkpunkte reinforced spring strut with different bolts for support of wishbone and for balancing of attachment points, <b>front</b>	Foto 6
7	701 a,b	Federbein verstärkt vorn mit unterschiedlichen Bolzen zur Aufnahme des Querlenkers und zum Ausgleich der Anlenkpunkte Material: Leichtmetall reinforced spring strut with different bolts for support of wishbone and for balancing of attachment points, <b>front</b> material: light alloy	Foto 7
7	701 a,b	Federbein verstärkt hinten mit unterschiedlichen Bolzen zur Aufnahme des Querlenkers und zum Ausgleich der Anlenkpunkte reinforced spring strut with different bolts for support of wishbone and for balancing of attachment points, <b>rear</b>	Foto 8
7	701 a,b	Federbein verstärkt hinten mit unterschiedlichen Bolzen zur Aufnahme des Querlenkers und zum Ausgleich der Anlenkpunkte Material: Leichtmetall reinforced spring strut with different bolts for support of wishbone and for balancing of attachment points, <b>rear</b> material: light alloy	Foto 9



B-264

Marke Audi  
Make

Modell Sport quattro S1  
Model

Homologations Nr. \_\_\_\_\_  
Homologation Nr.

02 / 02 V0

Fotos  
Photos

Nachtrag Nr. \_\_\_\_\_  
Ext. Nr.

6

7



8

9



Marke Audi  
 Make

Modell Sport quattro S1  
 Model

Homologations Nr. B-264  
 Homologation Nr.

02/02 VO

Nachtrag Nr. \_\_\_\_\_  
 Ext. Nr.

Seite od. Nachtrag Page or ext.	Artikel Art.	Beschreibung Description	
7	701 a,b	Verstärkter und verkürzter Spurhebel reinforced and shortened steering lever	Foto 12
	701 a,b	Spurstangen mit Unibalgelenken track rods with unibal joints	Foto 13
	701 a,b	direkte Spurstangenanlenkung direct track rod fitting	Foto 14
	701 a,b	Sicherheitslenksäule, längenveränderlich steering column, adjustable	Foto 15
	701 a,b	Kugelkopfgelenk für Federbein oben ballhead joint for sprint strut mounting, top	Foto 16
	701 a,b	Stabilisatoren vorne und hinten anti roll bars front and rear Form unverändert shape unchanged	Ø 19, 22, 25 , 28 mm
8	803 a	2 Hauptbremszylinder an Spritzwand 2 master cylinder splashwall	Ø 13/15" Foto 17



Marke Audi  
Make

Modell Sport quattro S1  
Model

Homologations Nr. \_\_\_\_\_  
Homologation Nr.

02 / 02 VO

Fotos  
Photos

Nachtrag Nr. \_\_\_\_\_  
Ext. Nr.

12



13



14



15



16



17

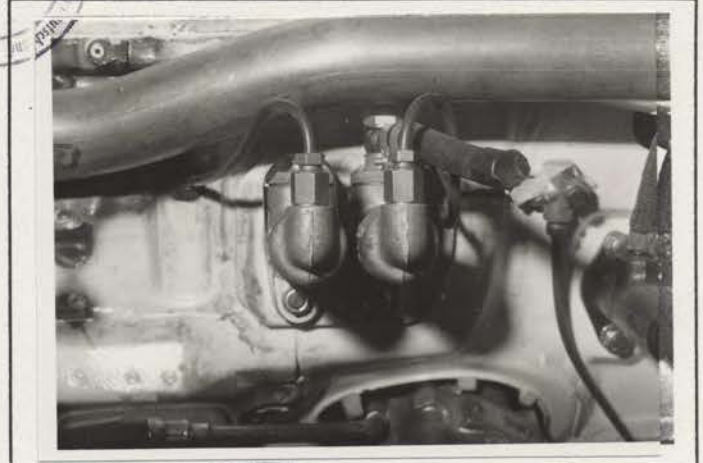

ONS  
Spezialkommission für den Automobilsport

ONS  
Spezialkommission für den Automobilsport

FEDERATION INTERNATIONALE  
F.I.S.A.  
DE L'AUTOMOBILE

Marke Audi  
Make

Modell Sport quattro S1  
Model

Homologations Nr. B-264  
Homologation Nr.  
02/02V0

Nachtrag Nr. \_\_\_\_\_  
Ext. Nr.

Seite od. Nachtrag Page or ext.	Artikel Art.	Beschreibung Description		
	803	Bremsen vorn und hinten brakes front and rear		
	e	4	Foto 22	Foto 23
	e1	42,5 mm		42,5 mm
	g1	2		2
	g2	1		1
	g3	Leichtmetall/light alloy		Leichtmetall/light alloy
	g4	25 mm		28 mm
	g5	280 mm		295 mm
	g6	280 mm		295 mm
	g7	<b>180 mm</b>		<b>195 mm</b>
	g8	125 mm		125 mm
	g9	ja/yes		ja/yes
	g10	722,5 cm <sup>2</sup>		770 cm <sup>2</sup>
		Pedalwerk mit Waagebalkensystem foot controls with brake balance		Foto 18
	803 h	Absperrventil anstelle Handbremse cut off valve instead of handbrake		Foto 19
	803 h1	Handbremse hydraulisch hydraulic handbrake		Foto 20



Marke Audi  
Make

Modell Sport quattro S1  
Model

Homologations Nr. B-264  
Homologation Nr.

Fotos  
Photos

Nachtrag Nr. 02/02 VO  
Ext. Nr.

18



19



20



22

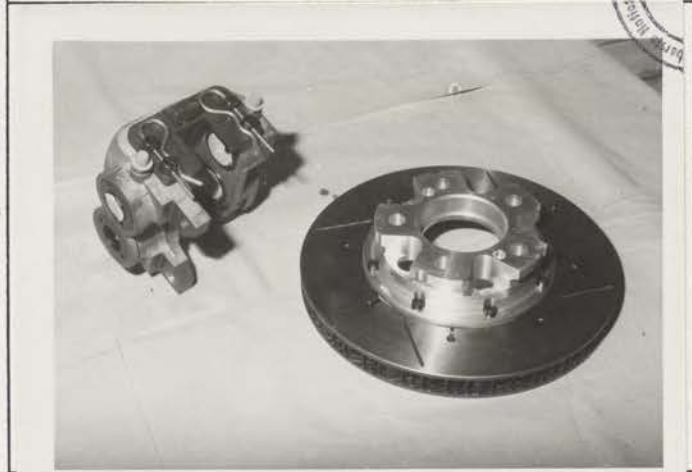

23

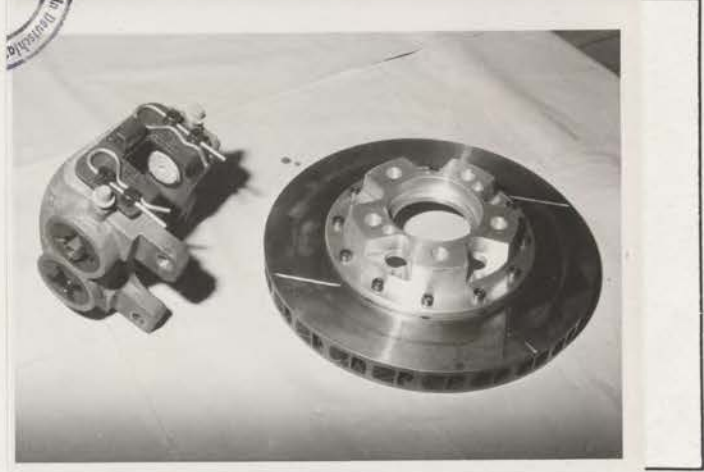



# FÉDÉRATION INTERNATIONALE DU SPORT AUTOMOBILE

ONS Oberste Nationale Sportkommission für den Automobilsport in Deutschland GmbH

Homologation Nr.

**B - 264**

Nachtrag Nr.  
Extension Nr.

**03 / 01 ET**

## Nachtrag zum offiziellen Testblatt der FISA

Form of extension to the official FISA-Homologation

**ET** Normale Weiterentwicklung des Typs: ab Fahrgestell -Nr.: \_\_\_\_\_  
Normal evolution of the type, as from chassis number

**VF** Liefervariante  
Supply variant

**VO** Ausstattungsvariante  
Content variant

**ER** Berichtigung  
Erratum

**01 MAI 1984**

Homologation gültig ab: \_\_\_\_\_ in Gruppe: B  
Homologation valid as from: \_\_\_\_\_ group

Hersteller: Audi NSU Auto Union AG Modell und Typ: Sport quattro S1  
Manufacturer: \_\_\_\_\_ Model and type: \_\_\_\_\_

Seite od. Nachtrag Page or add.	Artik. Nr.	Beschreibung Description	
		Rechte Seitenansicht Motor (ausgebaut) Right hand view of dismantled engine	Foto C1 Photo
		Linke Seitenansicht Motor (ausgebaut) Left hand view of dismantled engine	Foto D1 Photo
		Motor im Motorraum Engine in its compartment	Foto E1 Photo
		Einspritzsystem Injection system	Foto H1 Photo
		Getriebegehäuse und Kupplungsglocke Gearbox casing and clutch bellhousing	Foto S1 Photo
		Getriebegehäuse und Kupplungsglocke 2. Radsatz Gearbox casing and clutch bellhousing 2. set of gears	Foto S2 Photo

See page: N° 10/1



Marke AUDI  
Make

Modell SPORT QUATTRO S1  
Model

Homologations Nr. B-264  
Homologation Nr.

Nachtrag Nr. 03/01 ET  
Ext. Nr.

Seite od. Nachtrag  
Page or ext.

Artikel  
Art

Beschreibung  
Description

Foto A1



Foto B1



Marke Audi  
Modell

Modell Sport quattro S1  
Modell

Homologations Nr. B-264  
Homologation Nr.

Fotos  
Photos

ET

Nachtrag Nr. 03/01 ET  
Ext. Nr.

C1

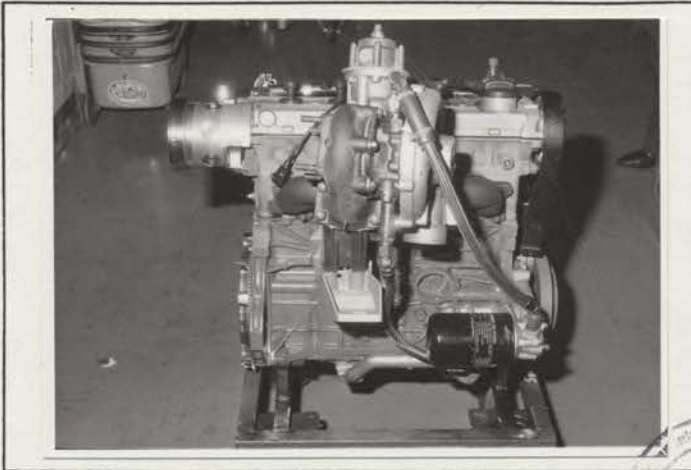

D1



E1



H1

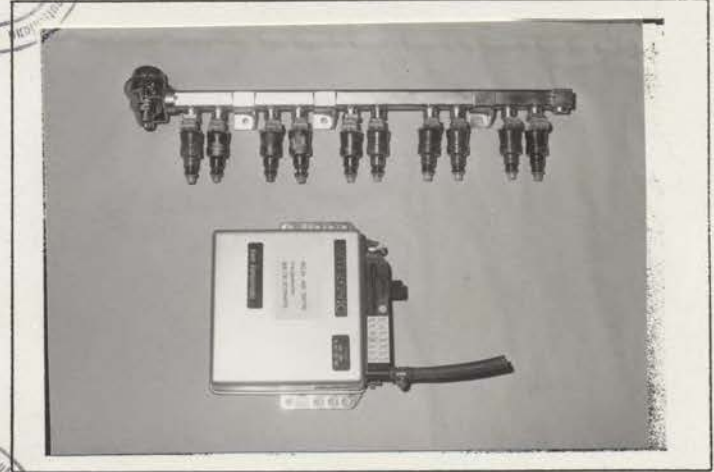

S2



Marke AUDI  
Make

Modell SPORT QUATTRO S1  
Model

Homologations Nr. B-264  
Homologation Nr.

Nachtrag Nr. 03/01 ET  
Ext. Nr.

Seite od. Nachtrag Page or ext.	Artikel Art	Beschreibung Description
		<u>2. Abmessungen/Dimensions</u>
	204 a	Breite, verbreitert 1817 mm width, extended 1817 mm
	204 b	Breite, verbreitert 1807 mm width, extended 1807 mm
		<u>Motor/Engine</u>
	307 a	Hubraum pro Zylinder/cylinder capacity unitary: 422 ccm
	307 b	Hubraum gesamt/cylinder capacity total: 2210 x 1,4 = 2954 ccm
	307 c	Maximal zulässiger Hubraum 2142 x 1,4 = 2999 ccm maximum total allowed: 2142 x 1,4 = 2999 ccm
	314	Bohrung 79,51 mm/Bore 79,51 mm
	315	Maximal zulässige Bohrung/Maximum bore allowed: 80,11
	316	Hub 85,0 mm/Stroke 85,0 mm
	318	Pleuel, Mindestgewicht 530 gr connecting rod, minimum weight
	318 c	50,6 mm
	318 d	140 mm
	319 h	Kurbelwelle, Mindestgewicht 11000 gr. crankshaft, minimum weight 11000 g
	320 b	Schwungrad, Mindestgewicht 5000 gr flywheel, minimum weight 5000 g
	326 e	Einlaß/inlet 10,55; outlet 10,55; Spiel/clearance 0,30 und/resp. 0,50 mm
	327e/f	8 mm 327f: 107 ± 0,5 mm
	328f/g	328f: 8 mm; 328g: 109,6 ± 0,5 mm

Bild 1

Bild 2



Bild 1

Bild 2

Marke AUDI  
Make

Modell SPORT QUATTRO S1  
Model

Homologation Nr. B-264  
Homologation Nr.

03/01 ET

**Zeichnungen**  
Drawings

**Motor**  
Engine

**I. Einlaßöffnungen im Ansaugkrümmer**  
Cylinderhead inlet ports, manifold side

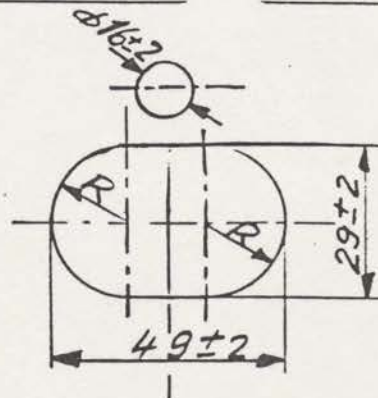

**II. Einlaßöffnungen im Zylinderkopf**  
Inlet manifold ports, cylinderhead side —

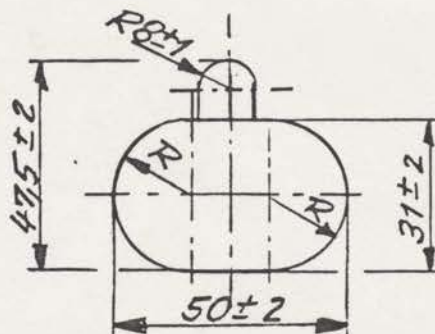

**III. Auslaßöffnungen im Auspuffkrümmer**  
Cylinderhead exhaust ports, manifold side —



**IV. Auslaßöffnungen im Zylinderkopf**  
Exhaust manifold ports, cylinderhead side —

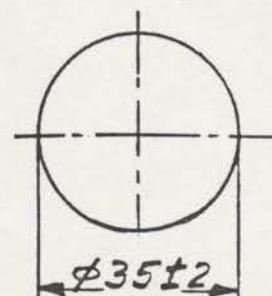

Marke AUDI  
 Make

Modell SPORT QUATTRO S1  
 Model

Homologations Nr. B-264  
 Homologation Nr. 03/01 ET

Nachtrag Nr. \_\_\_\_\_  
 Ext. Nr.

Seite od. Nachtrag Page or ext.	Artikel -	Beschreibung Description
	327 d	mod. Saugrohr mit Aufnahmen für die Einspritzdüsen mod. inlet manifold with brackets for fuel injection
	327 d	Max. Durchmesser der Ventile: 32,1 mm max. diameter of the valves: 32,1 mm
	328 f	Länge des Ventils: 107 ± 0,5 mm length of the valve 107 ± 0,5 mm
	328 e	Max. Durchmesser der Ventile: 28,1 mm max. diameter of the valves 28,1 mm
	328 g	Länge des Ventils: 109,6 ± 0,5 mm length of the valve: 109,6 ± 0,5 mm
<div data-bbox="467 1447 1073 1890" data-label="Image"> </div> <div data-bbox="316 1630 511 1825" data-label="Image"> </div> <div data-bbox="1079 1630 1429 1848" data-label="Image"> </div>		
		Schwingungsdämpfer/oscillation damp

Marke AUDI

Modell SPORT QUATTRO S1

Homologations Nr. B-264

Nachtrag Nr. 03/01 FT

Seite od. Nachtrag Page or ext.	Artikel Art.	Beschreibung Description
------------------------------------	-----------------	-----------------------------

324. Kraftstoffzufuhr durch Einspritzung  
Fuel feed by injection:

a) Hersteller Bosch  
Manufacturer

b) Modell des Einspritzsystems Sport-Einspritzung/sport injection  
Model of injection system

c) Art der Kraftstoffdosierung  mechanisch  elektronisch  hydraulisch  
Kind of fuel measurement mechanical electronic hydraulic

c1) Kolbenpumpe  ja /  nein  ja /  nein  
Piston pump yes/no Measurement of air volume yes/no

c3) Luftmassenmessung  ja /  nein c4) Luftgeschwindigkeitsmessung  ja /  nein  
Measurement of air mass yes/no Measurement of air speed yes/no

c5) Luftdruckmessung  ja /  nein Welcher Druck wird zur Messung herangezogen? bar  
Measurement of air pressure yes/no Which pressure is taken for measurement?

d) Abmessungen der Drosselklappe(n) oder der/des Schieber(s) 70 Saugrohrdruck/intake manifold pressure mm  
Effective dimensions of measure position in the throttle area

e) Anzahl der effektiven Kraftstoffauslässe 10  
Number of effective fuel outlets

f) Lage der Einspritzventile  Saugrohr  Zylinderkop  
Position of injection valves Inlet manifold Cylinderhead

g) Teile des Einspritzsystems, die zur Kraftstoffdosierung dienen: Systemdruckventil/system pressure valve,  
Statement of fuel measuring parts of injection system

Einspritzventile/injection valves, Steuergerät/control unit



Marke Audi  
Make

Modell Sport quattro S1  
Model

Homologations Nr. \_\_\_\_\_  
Homologation Nr.

**B-264**

**03/01 ET**

Nachtrag Nr. \_\_\_\_\_  
Ext. Nr.

Seite od. Nachtrag 6 Artikel 603 Beschreibung valid for evolution only  
Page or ext.

e) Übersetzungen  
Ratios

	Handschtaltung Manual			Zusätzl. Getriebe Additional G B		
	Über- setzungen ratio	Anzahl der Zähne number of teeth	synchro.	Über- setzungen ratio	Anzahl der Zähne number of teeth	synchro.
1	3,111	28:9	x	2,700	27:10	x
2	2,273	25:11	x	2,083	25:12	x
3	1,706	29:17	x	1,706	29:17	x
4	1,318	29:22	x	1,428	30:21	x
5	1,125	27:24	x	1,217	28:23	x
6				1,040	26:25	x
Rück wärts P	3,500	42:12		3,455	38:11	

f) Schalt-Schema  
Gear change gate

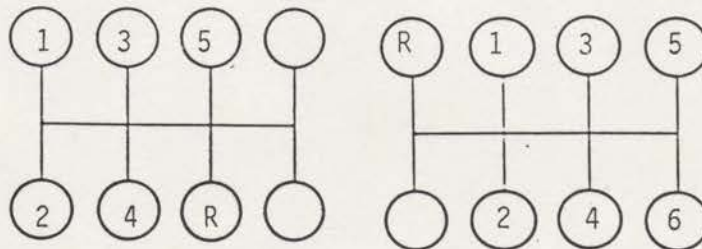

7

605

Achsantrieb / final drive

b 34/7; 37/7; 41/7

c 4,857; 5,286; 5,857





Marke Audi  
 Make

Modell Sport quattro S1  
 Model

Homologations Nr. \_\_\_\_\_  
 Homologation Nr.

03 / 01 ET

Nachtrag Nr. \_\_\_\_\_  
 Ext. Nr.

Seite od. Nachtrag Page or ext.	Artikel Art.	Beschreibung Description	
		Kunststoffzahnriemenschutz plastic cover for toothed belt	Foto 3
		Luftansaugkasten mit Filter air induction box with filter	Foto 4
		Modifizierter Getriebetunnel für geänderte Schaltbestätigung modified transmission tunnel for changed gear shift mechanism	Foto 5
		mod. Schaltbetätigung mod. gear shift mechanism	Foto 6
		Achsträger vorn, nachgeschweißt und verstärkt Getriebeaufnahme entfällt front axle beam rewelded and reinforced without gear box brackets	Foto 7
		Achsträger hinten, nachgeschweißt und verstärkt, Differentialaufnahme entfällt rear axle beam, rewelded and reinforced without differential carrier	Foto 8



Marke Audi  
 Make

Modell Sport quattro S1  
 Model

Homologations Nr. B-264  
 -omologation Nr.

Nachtrag Nr. 03/01 ET  
 Ext. Nr.

Seite od. Nachtrag Page or ext.	Artikel Art.	Beschreibung Description	
	902 c	Kunststofftüren plastic doors	
	902 h/1	geklebte Kunststoffscheiben plastic windows, bonded	
	902 k	Kunststofftürscheiben mit Schiebefenster plastic door windows with sliding window	
		mod. Armaturentafel mod. dash board	Foto 9
		mod. Spritzwand mod. splash wall	Foto 10
		mod. Längsträger hinten links u. rechts mod. rear chassis beam left and right	Foto 11
		mod. Motoraufhängungen links und rechts, Motorlage unverändert	Foto 12 Foto 13
		mod. engine lug left and right, location unchanged	
		mod. Differentialaufhängung mod. differential carrier	Foto 14

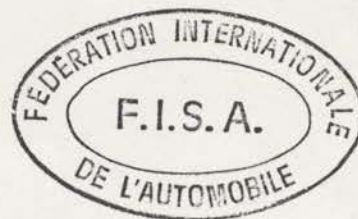

Marke Audi  
Mare

Modell Sport quattro S1  
Model

Homologations Nr. B-264  
Homologation Nr.

**03/01 FT**

Fotos  
Photos

Nachtrag Nr. \_\_\_\_\_  
Ext. Nr.

3

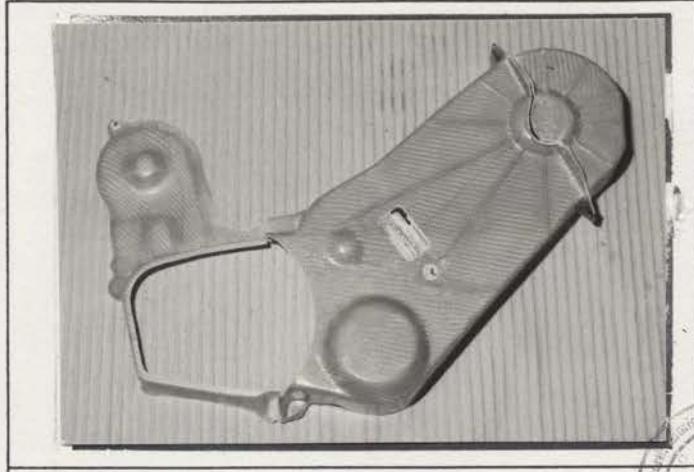

4



5

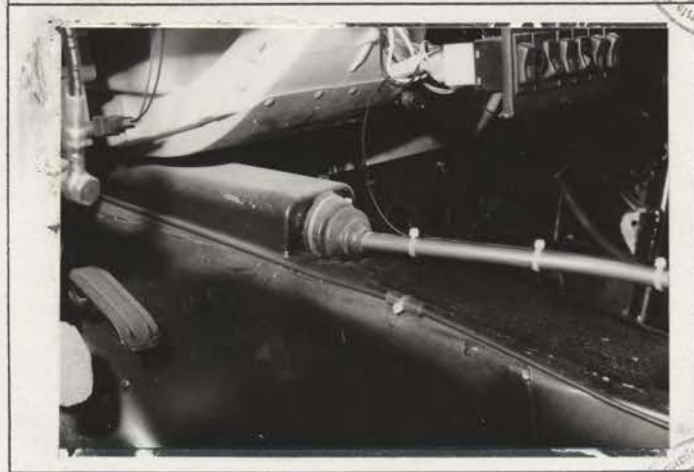

6

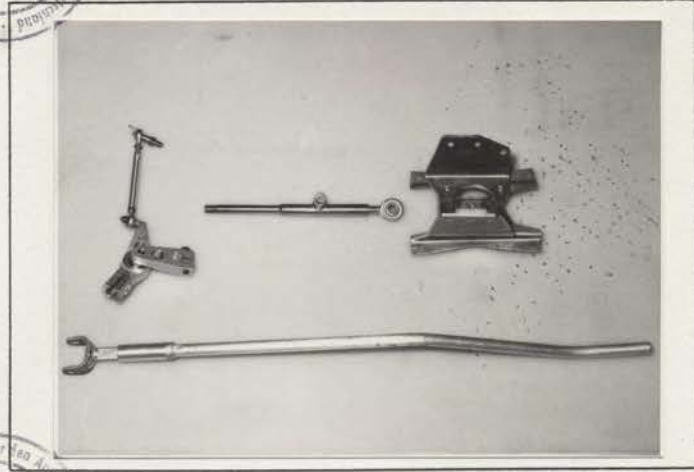

7

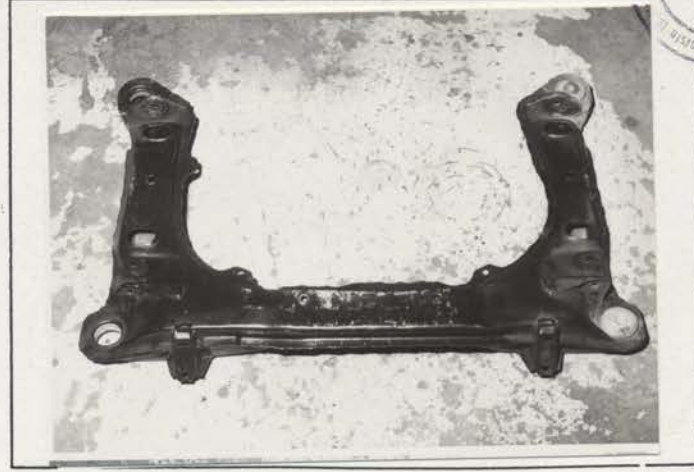

8



ONS  
Österreichischer  
Sportwagenverband

ONS  
Österreichischer  
Sportwagenverband

FEDERATION INTERNATIONALE  
F.I.S.A.  
DE L'AUTOMOBILE

Marke Audi  
Make

Modell Sport quattro S1  
Model

Homologations Nr. B-264  
Homologation Nr.

Fotos  
Photos

Nachtrag Nr. 03/01 ET  
Ext. Nr.

9



10

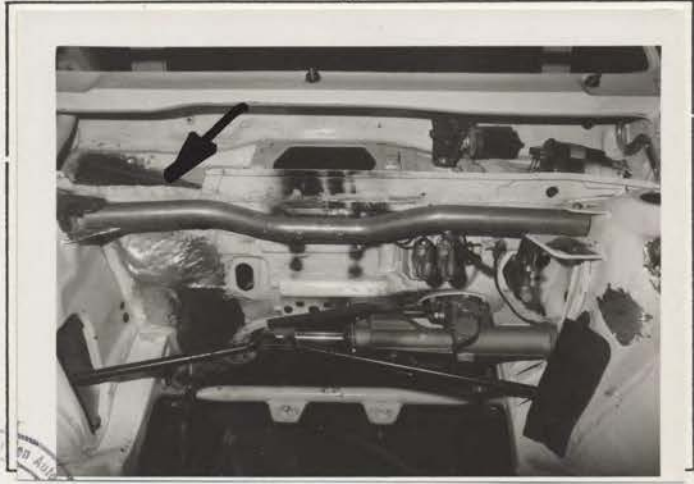

11



12

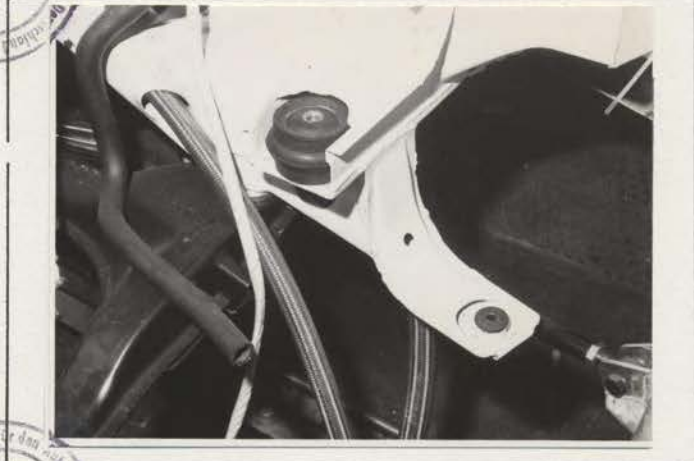

13



14

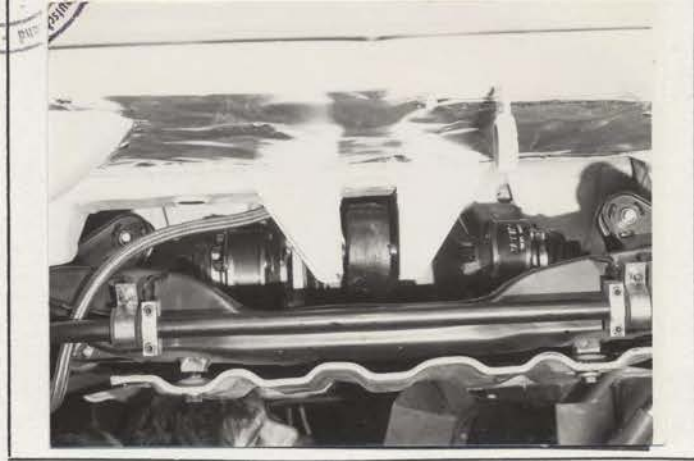

Seite od. Nachtrag Page or ext.	Artikel Art.	Beschreibung Description
		Heckspoiler rear spoiler <span style="float: right;">Foto 15</span> <div style="background-color: #e0e0e0; padding: 5px; margin: 5px 0;">             mod. Frontteil ohne Haubenschloß              mod. front part without lock for engine hood              Heckklappe ohne Schloß              boot lid without lock           </div> Servopumpe und Kraftstoffpumpe montiert am Zyl.-Kopf, Antrieb durch Nockenwelle pump for power assisted steering and fuel pump, mounted at cylinderhead, driven by camshaft <span style="float: right;">Foto 16</span> Ölkühler Oil cooler <span style="float: right;">Foto 15</span> Kühlluftführung für Hinterachs- und Bremsenkühlung air duct for rear axle and brake cooling <span style="float: right;">Foto 17</span> Anlenkung Spurstangen hinten geändert attachment points track rods rear changed <span style="float: right;">Foto 19</span> Karosserieverstärkung geschweißt body reinforcement <span style="float: right;">Foto 20 Foto 21 Foto 22</span> Querstrebe mit Karosserie verschraubt tie-rod attached on the body <span style="float: right;">Foto 23</span> ohne Stoßstange hinten without rear bumper <span style="float: right;">Foto 24</span> schmale Stoßstange vorn small front bumper <span style="float: right;">Foto 25</span> Radhaus vorn wheel housing front <span style="float: right;">Foto 26</span>



Marke AUDI  
Make

Modell SPORT QUATTRO S1  
Model

Homologations Nr. B-264  
Homologation Nr.

Fotos  
Photos

Nachtrag Nr. 03/01 ET  
Ext. Nr.

15

16

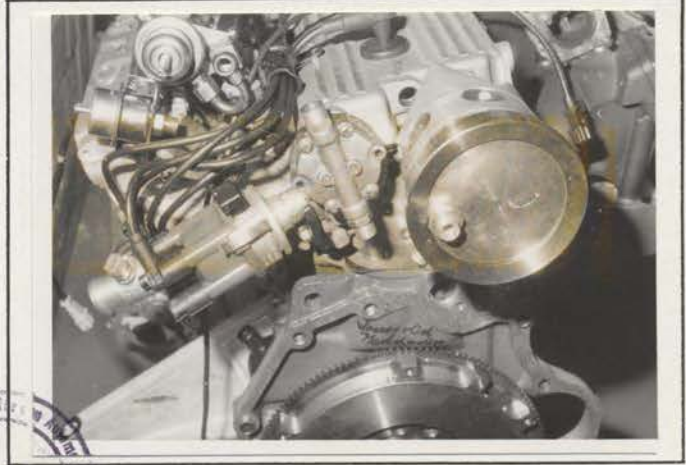

17



19

20



Marke Audi  
Marque

Modell Sport quattro S1  
Modèle

Homologations Nr. B-264  
Homologation Nr.

Fotos  
Photos

Nachtrag Nr. 03/01 ET  
Ext. Nr.

21



22



23



24



25



26





# FEDERATION INTERNATIONALE DU SPORT AUTOMOBILE

Homologation N°

**B-264**

**03/01ET**

Groupe **A/B**  
Group

FICHE D'HOMOLOGATION ADDITIONNELLE POUR MOTEURS SURALIMENTÉS PAR TURBOCOMPRESSEUR(S)  
ADDITIONAL HOMOLOGATION FORM FOR TURBO CHARGED ENGINES

Véhicule : Constructeur AUDI NSU AUTO UNION AG Modèle et type SPORT QUATTRO S1  
Vehicle : Manufacturer AUDI NSU AUTO UNION AG Model and type SPORT QUATTRO S1

Homologation valable à partir du \_\_\_\_\_ en groupe B  
Homologation valid as from \_\_\_\_\_ in group

334. Suralimentation  
Turbocharging

a) Marque et type du turbo compresseur KKK/K27  
Make and type of the turbocharger

b) Carter de turbine :  
Turbine housing :

b1) Nombre d'entrées des gaz d'échappement 1  
Number of exhaust gas entries

b2) Matériau Cr NiSi-Legierung / alloy  
Material

c) Roue de turbine :  
Turbine wheel :

c1) Matériau Nickellegierung / Ni-alloy  
Material

c2) Nombre d'aubes 12  
Number of blades

c3) Hauteur(s) d'une aube 11,5 mm  
Height(s) of blade

c4) Préciser les cotes A,B,C, selon le schéma suivant :  
Indicate the dimensions A, B, C, according to the following sketch :

A = 64,0 mm  
B = 11,5 mm  
C = 76,2 mm

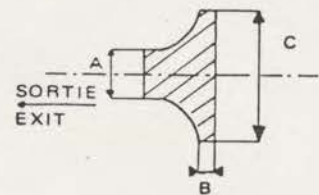

d) Carter de compression :  
Impeller housing :

d1) Nombre d'entrée d'air (mélange) 1  
Number of air entries (gas)

d2) Matériau Leichtmetallegerung / light alloy  
Material

e) Roue de compression  
Impeller wheel :

e2) Nombre d'aubes 12  
Number of blades

e3) Hauteur(s) d'une aube 8 mm  
Height(s) of blade

e4) Préciser les cotes A, B, C selon le schéma suivant :  
Indicate the dimensions A, B, C, according to the following sketch,

A = 60,9 mm  
B = 8,0 mm  
C = 87,0 mm

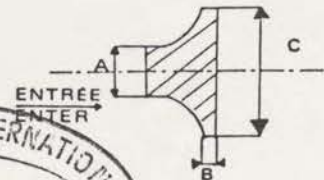

ET-14





Marque Make AUDI Modèle Model SPORT QUATTRO S1 N° Homol. B-264

03/01ET

f) Régulation de la pression :  
Pressure regulation :

f1) Type de régulation de la pression :  by-pass  soupape de décharge  autre cas  
Type of pressure adjustment :  by-pass  relief valve  other case

f2) Préciser le type de la soupape et son contrôle  
Indicate the type of the valve and its control Abblaseventil pneumatisch-elektrisch  
wastegate pneumatic-electric

g) Système d'échappement :  
Exhaust system :

Dimensions intérieures de l'éventuel tuyau d'échappement entre le collecteur d'échappement et le turbocompresseur (dessin)  
Internal dimensions of the eventual exhaust pipes between exhaust manifold and turbocharger (sketch)

h) Refroidissement de l'air d'admission :  oui /  non  
Cooling of intake air :  yes /  no  
mit Wassereinspritzung / tank capacity : 15 L  
with water injection



PHOTOS

k) Vue de dessus du turbo compresseur  
Plan view of turbocharger



l) Vue de face du turbo compresseur  
Front view of turbocharger



Marque AUDI  
Make

Modèle SPORT QUATTRO S1  
Model

**B - 264**  
N° Homol. \_\_\_\_\_

M) Vue de côté du turbocompresseur  
Side view of turbocharger



N) Carter de turbine du turbocompresseur **03 / 01 ET**  
Turbine housing of turbocharger



O) Soupape et montage du by-pass du turbocompresseur  
Valve and by-pass installation of turbocharger

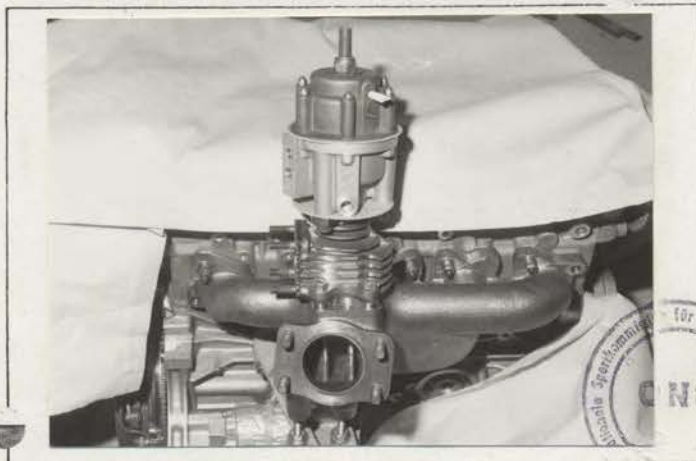

P) Eventuel échappement entre le collecteur d'échappement et le turbocompresseur.

Eventual exhaust pipes between the exhaust manifold and the turbocharger.



Q) Carter de compression du turbocompresseur  
Impeller housing of turbocharger



Wassereinspritzung  
water injection

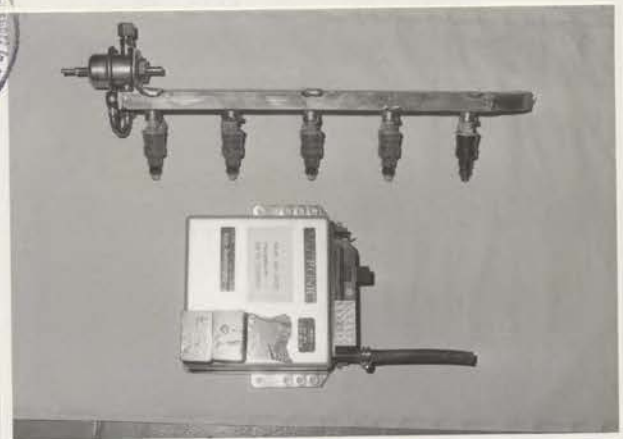

DESSINS / DRAWINGS

V) Entrée des gaz d'échappement dans le carter de turbine du turbocompresseur  
 Exhaust gas entry in the turbine housing of turbocharger.

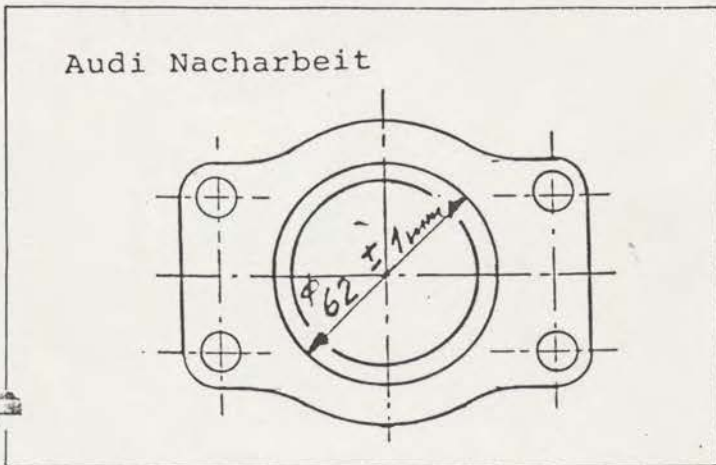

VI) Sortie des gaz d'échappement du carter de turbine de turbocompresseur.  
 Exhaust gas exit of the turbine housing of turbocharger.

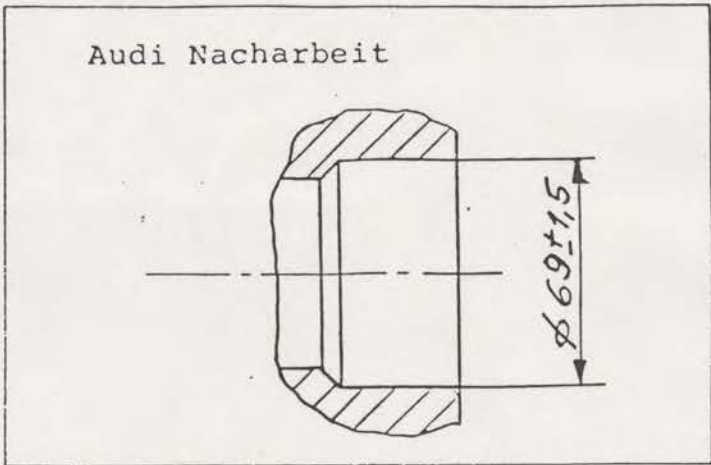

VII) Entrée de l'air (mélange) dans le carter de compression du turbocompresseur.  
 Air (gas) entry in the impeller housing of the turbocharger

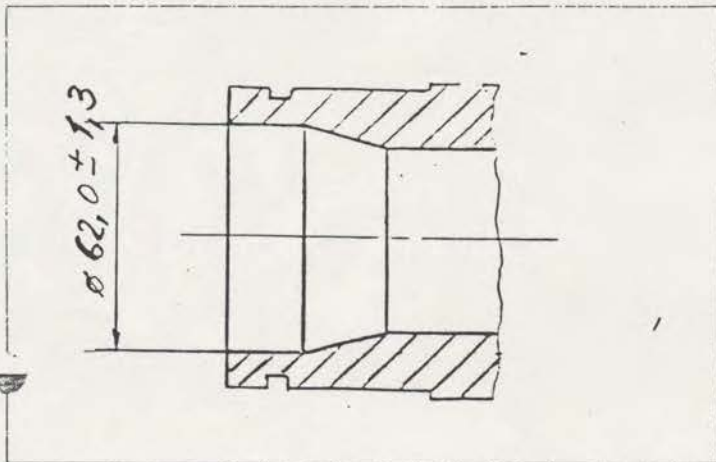

VIII) Sortie de l'air (mélange) du carter de compression du turbocompresseur.  
 Air (gas) exit of the impeller housing of the turbocharger.

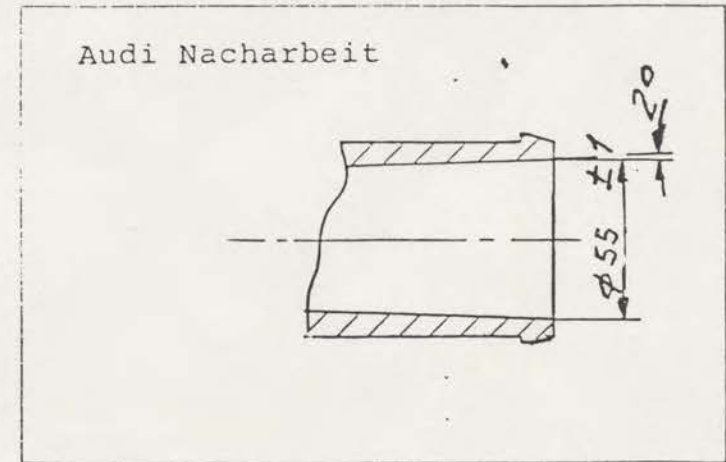

IX. Dispositif réglant la pression de suralimentation  
 Device regulating the turbocharging pressure.

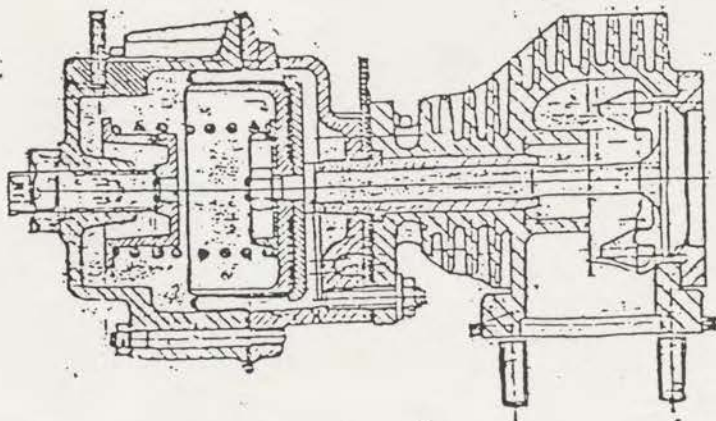

Marke AUDI  
Make

Modell SPORT QUATTRO S1  
Model

Homologations Nr. B-264  
Homologation Nr.

**03/01 ET**

Nachtrag Nr. \_\_\_\_\_  
Ext. Nr.

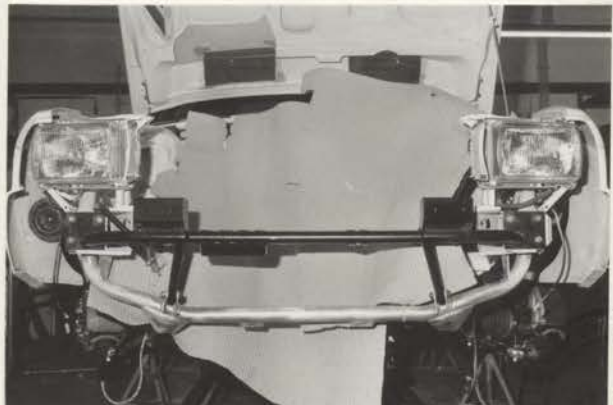
Seite od. Nachtrag Page or ext.	Artikel Art	Beschreibung Description
		<p data-bbox="487 459 1364 560">Querstreben verstärkt mit Verbindungsstreben, gleiches Material reinforced cross strut (material unchanged)</p>  <p data-bbox="1096 918 1291 1120">Für den Austausch des in der Abbildung gezeigten Querstrebens 18 Österreichischer Automobilclub - OÖ</p>



# FÉDÉRATION INTERNATIONALE DU SPORT AUTOMOBILE

ONS Oberste Nationale Sportkommission für den Automobilsport in Deutschland GmbH

Homologation Nr.

B 264

Nachtrag Nr.

Extension Nr.

04 / 03 VO

## Nachtrag zum offiziellen Testblatt der FISA

Form of extension to the official FISA-Homologation:

- ET Normale Weiterentwicklung des Typs; ab Fahrgestell -Nr.: \_\_\_\_\_  
Normal evolution of the type; as from chassis number:
- VF Liefervariante  
Supply variant
- VO Ausstattungsvariante  
Option variant
- ER Berichtigung  
Erratum

- 1 JUL. 1984

Homologation gültig ab: \_\_\_\_\_ in Gruppe: \_\_\_\_\_  
Homologation valid as from: \_\_\_\_\_ in group

Hersteller: AUDI NSU AUTO UNION AG Modell und Typ: Audi Sport quattro S1  
Manufacture: \_\_\_\_\_ Model and type

Seite od. Nachtrag Page or Ext	Artikel Art.	Beschreibung Description
		Stabilisator verstellbar anti roll bar adjustable vorn u. hinten front and rear Foto 24
		Anlenkpunkte modifiziert, Lage unverändert mounting points modified, location unchanged
		Querlenker verstärkt mit Unibalgelenk reinforced wishbone with unibal joint Foto 25
		Bremskühlung mit elektrischen Pumpen brake cooling with electrical pumps Foto 26
		Tankinhalt max 50 Ltr tank capacity max 50 ltr water / wasser



*[Handwritten signature]*



Marke AUDI  
Make

Modell SPORT QUATTRO S1  
Model

Homologations Nr. B 264  
Homologation Nr.

04 / 03 VO

Fotos  
Photos

Nachtrag Nr. \_\_\_\_\_  
Ext. Nr.

Foto 24



Foto 25



Foto 26

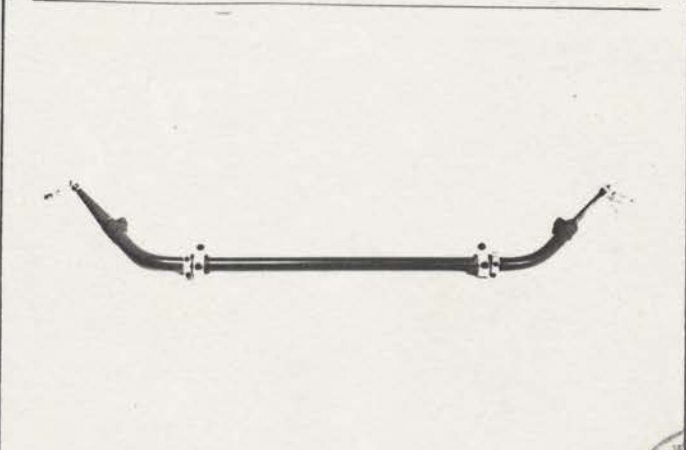

Homologation Nr.

B 264

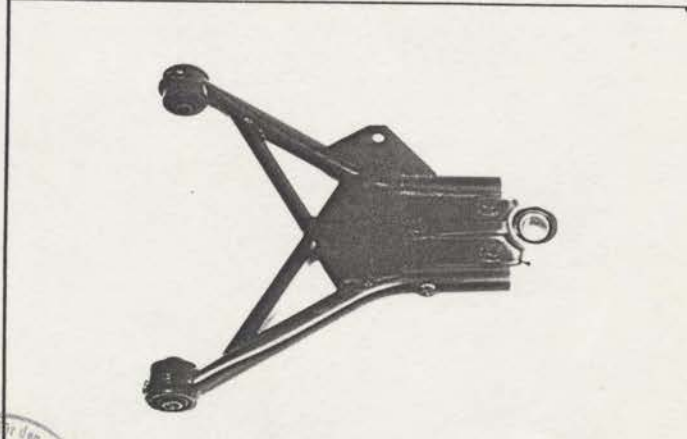
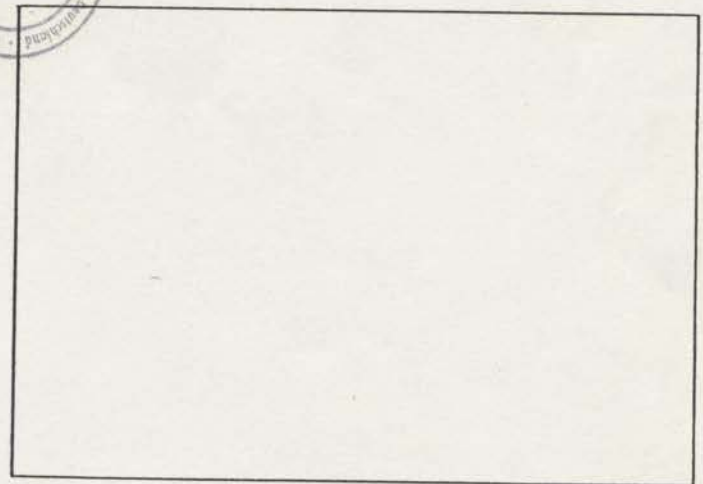
Nachtrag Nr.  
Extension Nr.

**05 / 04 VO**

**Nachtrag zum offiziellen Testblatt der FISA**

Form of extension to the official FISA-Homologation

- ET** Normale Weiterentwicklung des Typs: ab Fahrgestell -Nr.: \_\_\_\_\_  
Normal evolution of the type: as from chassis number:
- VF** Liefervariante  
Supply variant
- VO** Ausstattungsvariante  
Option variant
- ER** Berichtigung  
Erratum

Homologation gültig ab: 01 JAN. 1985 in Gruppe: \_\_\_\_\_  
-omologation valid as from in group

Hersteller: AUDI AG Modell und Typ: Sport quattro S1  
Manufacturer Model and type

Seite od. Nachtrag <small>Page or ext.</small>	Artikel <small>Art.</small>	Beschreibung <small>Description</small>
7	605	Achsantrieb / final drive
	b	32/7, 39/7
	c	4,571, 5,571



# FÉDÉRATION INTERNATIONALE DU SPORT AUTOMOBILE

ONS Oberste Nationale Sportkommission für den Automobilsport in Deutschland GmbH

Homologation Nr.

**B - 264**

Nachtrag Nr.  
Extension Nr.

**06 - 01 ER**

## Nachtrag zum offiziellen Testblatt der FISA

Form of extension to the official FISA-Homologation

- ET** Normale Weiterentwicklung des Typs: ab Fahrgestell -Nr.: \_\_\_\_\_  
Normal evolution of the type: as from chassis number:
- VF** Liefervariante  
Supply variant
- VO** Ausstattungsvariante  
Option variant
- ER** Berichtigung  
Erratum

Homologation gültig ab: 01 FEV. 1985 in Gruppe: B  
Homologation valid as from in group

Hersteller: AUDI NSU AUTO UNION AG Modell und Typ: Audi Sport quattro S 1  
Manufacturer Model and type

Seite od. Nachtrag Page or ext.	Artikel Art.	Beschreibung Description
2	206	Radstand/Wheelbase Falsch/Wrong a,b) 2204
		Richtig/Read ab) 2224
2	209	Überhang/overhang falsch/wrong b) 982
		richtig/read b) 962



*Signature*



# FÉDÉRATION INTERNATIONALE DU SPORT AUTOMOBILE

ONS Oberste Nationale Sportkommission für den Automobilsport in Deutschland GmbH

Homologation Nr.

B 2 6 4

Nachtrag Nr.  
Extension Nr.

07 - 02 ER

## Nachtrag zum offiziellen Testblatt der FISA

Form of extension to the official FISA-Homologation

- ET** Normale Weiterentwicklung des Typs: ab Fahrgestell -Nr.: \_\_\_\_\_  
Normal evolution of the type: as from chassis number:
- VF** Liefervariante  
Supply variant
- VO** Ausstattungsvariante  
Option variant
- ER** Berichtigung  
Erratum

01 AVR. 1985

Homologation gültig ab: \_\_\_\_\_ in Gruppe: B  
Homologation valid as from in group

Hersteller: AUDI AG Modell und Typ: Sport quattro S 1  
Manufacturer Model and type

Seite od. Nachtrag Page or ext.	Artikel Art	Beschreibung Description
ET 03/01  Seite ET 2 page ET 2	Photo J	Foto nicht vorhanden in ET-Blatt photo not fitted by mistake in ET-form  Auslaßöffnungsdurchmesser unverändert exhaust ports diameter unchanged

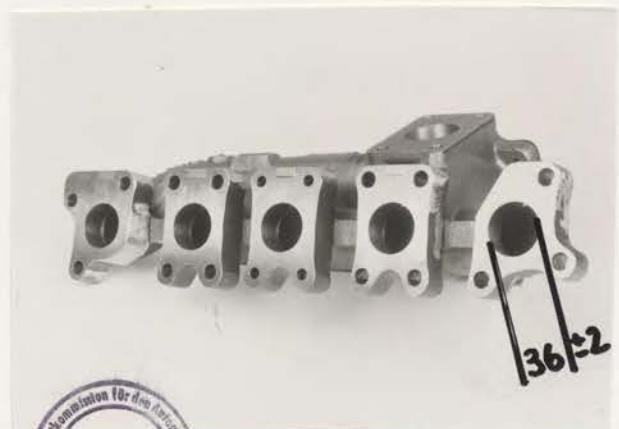
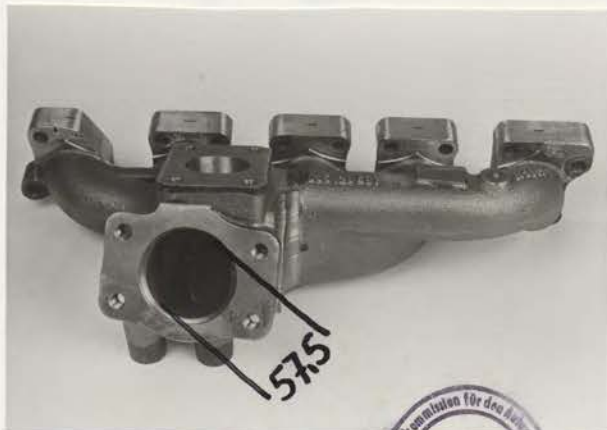

*Handwritten signature*

# FÉDÉRATION INTERNATIONALE DU SPORT AUTOMOBILE

ONS Oberste Nationale Sportkommission für den Automobilsport in Deutschland GmbH

Homologation Nr.

B 264

Nachtrag Nr.  
Extension Nr.

08 - 05 VO

## Nachtrag zum offiziellen Testblatt der FISA

Form of extension to the official FISA-Homologation

- ET** Normale Weiterentwicklung des Typs: ab Fahrgestell -Nr.: \_\_\_\_\_  
Normal evolution of the type: as from chassis number:
- VF** Liefervariante  
Supply variant
- VO** Ausstattungsvariante  
Option variant
- ER** Berichtigung  
Erratum

01 AVR. 1985

Homologation gültig ab: \_\_\_\_\_ in Gruppe: B  
Homologation valid as from in group

Hersteller: AUDI AG Modell und Typ: Sport quattro S1  
Manufacturer Model and type

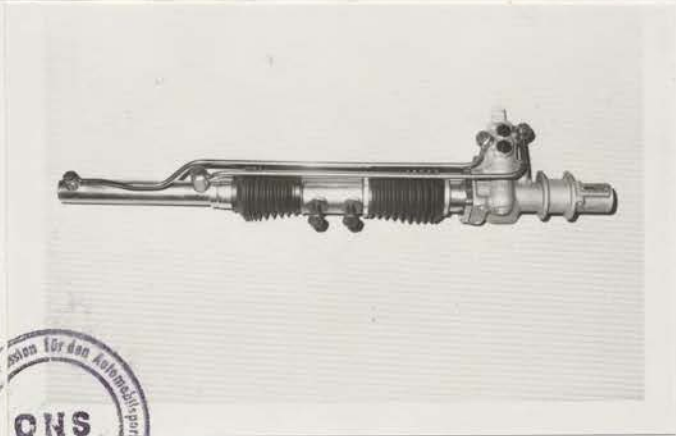
Seite od. Nachtrag Page or ext.	Artikel Art.	Beschreibung Description
9	804	Servolenkung, Übersetzung 54 : 1 power steering, ratio 54 : 1 Teile-Nr./part nr. SV 859 422 065
		



*Signature*

Marke Audi  
Make

Modell Sport quattro S1  
Model

Homologations Nr. B 264  
Homologation Nr.

**08 - 05 V0**

Nachtrag Nr. \_\_\_\_\_  
Ext. Nr.

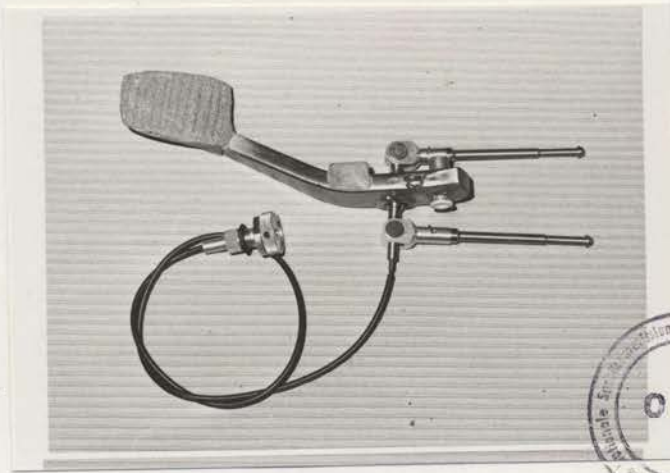
Seite od. Nachtrag Page or ext.	Artikel Art.	Beschreibung Description
Seite/page V07/V08 Foto 18 02/02 V0	803	Bremsen / brakes Waagebalken mit Verstelleinrichtung brake balance system adjustable Teile-Nr./part nr. SV 859 700 051 A 



Marke Audi  
Make

Modell Sport quattro S1  
Model

Homologations Nr. B 264  
Homologation Nr.

**08 - 05 VO**

Nachtrag Nr. \_\_\_\_\_  
Ext. Nr.

Seite od. Nachtrag Page or ext.	Artikel Art	Beschreibung Description
8	803	BREMSEN / brakes AP 15" Teile-Nr./part nr. SV 859 615 105/106 SV 859 615 405/406

	Vorn Front	Hinten Rear
e) Anzahl der Zylinder je Rad Number of cylinders per wheel	4	4
1) Bohrung Bore	∅ 41,3 mm	∅ 31 mm
g) Scheibenbremsen Disc brakes		
1) Anzahl der Bremsbeläge je Rad Number of pads per wheel	2	2
2) Anzahl der Sättel je Rad Number of calipers per wheel	1	1
3) Material der Bremssättel Caliper material	Leichtmetall/light alloy	Leichtmetall/light alloy
4) Maximale Dicke der Scheibe Maximum disc thickness	28 mm SV 859 615 301/302	25,4 mm SV 857 615 301/302
5) Außendurchmesser der Scheibe Exterior diameter of the disc	295 mm (± 1 mm)	280 mm (± 1 mm)
6) Außendurchmesser der Belagfläche Exterior diameter of the shoes rubbing surface	295 mm	280 mm
7) Innendurchmesser der Belagfläche Interior diameter of the shoes rubbing surface	193 mm	178 mm
8) Länge der Beläge über Alles Overall length of the shoes	125 mm	125 mm
9) Belüftete Scheiben Ventilated disc	ja / <del>nein</del> yes/ <del>no</del>	ja / <del>nein</del> yes/ <del>no</del>
10) Bremsfläche je Rad Braking surface per wheel	782 qcm	733 qcm

VA

HA

FOTO 23

Seite / page vo 8



Marke Audi  
 Make

Modell Sport quattro S1  
 Model

Homologations Nr. B 264  
 Homologation Nr.

**08 - 05 V0**

Nachtrag Nr. \_\_\_\_\_  
 Ext. Nr.

Seite od. Nachtrag Page or ext.	Artikel Art.	Beschreibung Description
8	803	BREMSEN / brakes 16" Girling Teile-Nr./part Nr. SV 859 615 105B/106B SV 859 615 405A/406A

	Vorn Front	Hinten Rear
e) Anzahl der Zylinder je Rad Number of cylinders per wheel	4	4
1) Bohrung Bore	43 mm	33,9 mm
g) Scheibenbremsen Disc brakes		
1) Anzahl der Bremsbeläge je Rad Number of pads per wheel	2	2
2) Anzahl der Sättel je Rad Number of calipers per wheel	1	1
3) Material der Bremssättel Caliper material	Leichtmetall/light alloy	Leichtmetall/light alloy
4) Maximale Dicke der Scheibe Maximum disc thickness	30 mm	22,2 mm
5) Außendurchmesser der Scheibe Exterior diameter of the disc	SV 859 615 301B/302B 330 mm (± 1 mm)	SV 859 615 301C/302C 280 mm (± 1 mm)
6) Außendurchmesser der Belagfläche Exterior diameter of the shoes rubbing surface	330 mm	280 mm
7) Innendurchmesser der Belagfläche Interior diameter of the shoes rubbing surface	218 mm	180 mm
8) Länge der Beläge über Alles Overall length of the shoes	98 mm	94 mm
9) Belüftete Scheiben Ventilated disc	ja / <del>xxx</del> yes/	ja / <del>xxx</del> yes/
10) Bremsfläche je Rad Braking surface per wheel	964,5 qcm	722 qcm

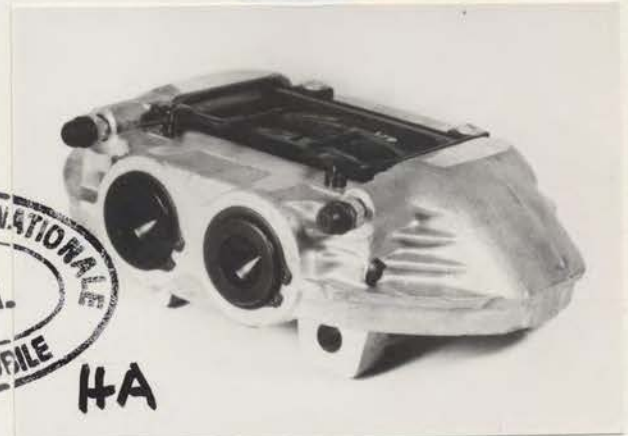
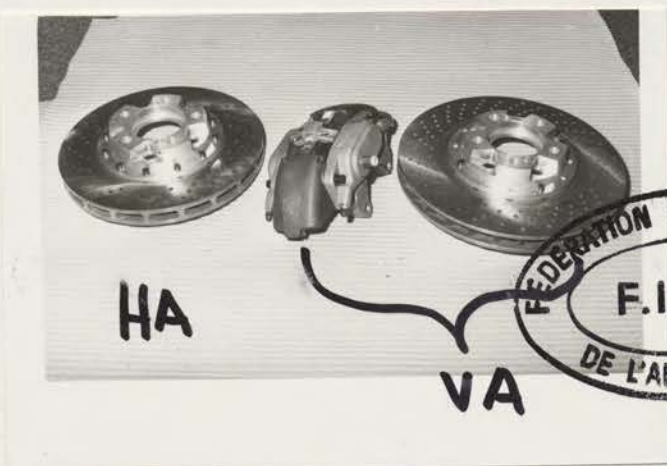

Marke Audi  
Make

Modell Sport quattro S1  
Model

Homologations Nr. B 264  
Homologation Nr.

Nachtrag Nr. 08 - 05 V0  
Ext. Nr.

Seite od. Nachtrag Page or ext.	Artikel Art	Beschreibung Description
8	803	BREMSEN / brakes IPASCO Teile-Nr./part nr. SV 859 615 105C/D//106C/D SV 859 615 405B/406B

	Vorn Front	Hinten Rear
e) Anzahl der Zylinder je Rad Number of cylinders per wheel	4	4
1) Bohrung Bore	$44,4 \begin{matrix} 4x \\ // \\ 2x \end{matrix} 44,4$ mm $40,7 \begin{matrix} 2x \end{matrix}$	34,9 mm
g) Scheibenbremsen Disc brakes	2	2
1) Anzahl der Bremsbeläge je Rad Number of pads per wheel	1	1
2) Anzahl der Sättel je Rad Number of callipers per wheel		
3) Material der Bremssättel Caliper material	Leichtmetall/light alloy	Leichtmetall/light alloy
4) Maximale Dicke der Scheibe Maximum disc thickness	32 mm SV 859 615 301 D	25,4 mm SV 857 615 301/302
5) Außendurchmesser der Scheibe Exterior diameter of the disc	330 mm (± 1 mm)	280 mm (± 1 mm)
6) Außendurchmesser der Belagfläche Exterior diameter of the shoes rubbing surface	330 mm	280 mm
7) Innendurchmesser der Belagfläche Interior diameter of the shoes rubbing surface	202 mm	181 mm
8) Länge der Beläge über Alles Overall length of the shoes	117,5 mm	95 mm
9) Belüftete Scheiben Ventilated disc	ja / <del>XXXX</del> yes/	ja / <del>XXXX</del> yes/
10) Bremsfläche je Rad Braking surface per wheel	1069 qcm	716 qcm

VA

HA



Marke Audi  
 Make

Modell Sport quattro S1  
 Model

Homologations Nr. B 264  
 Homologation Nr.

**08 - 05 V0**

Nachtrag Nr. \_\_\_\_\_  
 Ext. Nr.

Seite od. Nachtrag Page or ext.	Artikel Art	Beschreibung Description
8	803	BREMSEN / brakes 15" Girling SV 859 615 105A/106A Teilennr./Part nr. SV 859 615 105A/106A

	Vorn Front	Hinten Rear
e) Anzahl der Zylinder je Rad Number of cylinders per wheel	4	4
1) Bohrung Bore	∅ 43 mm	∅ 43 mm
g) Scheibenbremsen Disc brakes		
1) Anzahl der Bremsbeläge je Rad Number of pads per wheel	2	2
2) Anzahl der Sättel je Rad Number of calipers per wheel	1	1
3) Material der Bremssättel Caliper material	Leichtmetall/light alloy	Leichtmetall/light alloy
4) Maximale Dicke der Scheibe Maximum disc thickness	28 mm	28 mm
5) Außendurchmesser der Scheibe Exterior diameter of the disc	SV 859 615 301A/302A 304 mm (± 1 mm)	SV 859 615 301A/302A 304 mm (± 1 mm)
6) Außendurchmesser der Belagfläche Exterior diameter of the shoes rubbing surface	304 mm	304 mm
7) Innendurchmesser der Belagfläche Interior diameter of the shoes rubbing surface	202 mm	202 mm
8) Länge der Beläge über Alles Overall length of the shoes	98 mm	98 mm
9) Belüftete Scheiben Ventilated disc	ja / <del>nein</del> yes/ <del>no</del>	ja / <del>nein</del> yes/ <del>no</del>
10) Bremsfläche je Rad Braking surface per wheel	810 qcm	810 qcm



# FÉDÉRATION INTERNATIONALE DU SPORT AUTOMOBILE

ONS Oberste Nationale Sportkommission für den Automobilsport in Deutschland GmbH

Homologation Nr.

B 264

Nachtrag Nr.  
Extension Nr.

09 - 06 VO

## Nachtrag zum offiziellen Testblatt der FISA

Form of extension to the official FISA-Homologation

- ET** Normale Weiterentwicklung des Typs: ab Fahrgestell -Nr.: \_\_\_\_\_  
Normal evolution of the type: as from chassis number:
- VF** Liefervariante  
Supply variant
- VO** Ausstattungsvariante  
Option variant
- ER** Berichtigung  
Erratum

01 AVR. 1985

Homologation gültig ab: \_\_\_\_\_ in Gruppe: B  
Homologation valid as from in group

Hersteller: AUDI AG Modell und Typ: Sport quattro S1  
Manufacturer Model and type

Seite od. Nachtrag Page or ext.	Artikel Art	Beschreibung Description
10	701	<p>exzentrisches Federbeinlager oben verstärkt, Lage der Aufhängungspunkte unverändert Teile Nr.: SV 859 412 255/256</p> <p>eccentric reinforced strut top mounting, position of the mounting points unchanged part Nr.: SV 859 412 255/256</p> <div style="text-align: center;">  </div>





# FÉDÉRATION INTERNATIONALE DU SPORT AUTOMOBILE

ONS Oberste Nationale Sportkommission für den Automobilsport in Deutschland GmbH

Homologation Nr.

B 264

Nachtrag Nr.  
Extension Nr.

10 - 07 VO

## Nachtrag zum offiziellen Testblatt der FISA

Form of extension to the official FISA-Homologation

VO Ausstattungsvariante  
Option variant

Homologation gültig ab - 1 JULI 1985 in Gruppe A  
Homologation valid as from in group

Fahrzeughersteller Audi AG Modell und Typ Audi Sport quattro S 1  
Manufacturer of the car Model and type

### Überrollbügel/-käfig

Rollbar/rollcage

Hauptbügel  
Main rollbar

Diagonalstrebe  
Longitudinal/diagonal strut

Vorderbügel  
Front rollbar

Bügelhersteller  
Rollbar manufacturer

Winfried Matter GmbH, Industriegebiet, D-7523 Graben-Neudorf

Material  
Material

Al Zn Mg1 Al Zn Mg 1/ Al Zn Mg1

Außendurchmesser  
Exterior diameter

40 mm 40 mm/ mm 40 mm

Wandstärke  
Wall thickness

3 mm 3 mm/ mm 3 mm

Streckgrenze  
Elastic limit

30 kg/mm<sup>2</sup> 30 kg/mm<sup>2</sup>/ kg/mm<sup>2</sup> 30 kg/mm<sup>2</sup>

Zugfestigkeit  
Tensile strength

36 kg/mm<sup>2</sup> 36 kg/mm<sup>2</sup>/ kg/mm<sup>2</sup> 36 kg/mm<sup>2</sup>

Gesamtgewicht inkl.  
Befestigungsvorrichtungen  
Total weight including fixings

32 kg

Kompletter Überrollbügel/-käfig ausgebaut  
Complete rollbar/rollcage outside the car

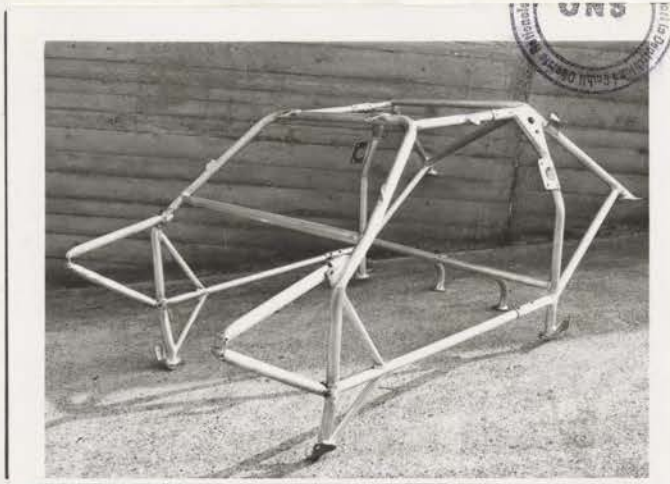

Hiermit wird bestätigt, daß der beschriebene Überrollbügel/-käfig den Anforderungen des Anhangs J der FISA entspricht, insbesondere in Bezug auf seine Befestigungen, Verbindungen und Beanspruchungswerte.

We certify that the present rollbar/rollcage complies with the conditions of the FIA Appendix J, in particular with regard to its attachments, its connections and its stress resistances.

*[Signature]*  
Unterschrift des Fahrzeugherstellers  
Signature of the car manufacturer representative



Marke Audi  
Make

Modell Sport quattro S 1  
Model

Homologation Nr. B 264  
Homologation Nr.

Fotos oder Zeichnungen der Befestigungen an der Karosserie:  
Photos or drawings of the attachments on the Body:

Nachtrag Nr. 10-07 VO  
Ext. Nr.

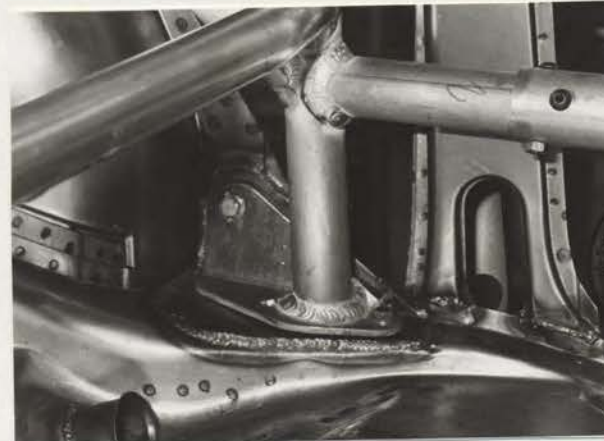

# FÉDÉRATION INTERNATIONALE DU SPORT AUTOMOBILE

ONS Oberste Nationale Sportkommission für den Automobilsport in Deutschland GmbH

Homologation Nr.

B 2 6 4

Nachtrag Nr.  
Extension Nr.

11-08 VO

## Nachtrag zum offiziellen Testblatt der FISA

Form of extension to the official FISA-Homologation

**ET** Normale Weiterentwicklung des Typs: ab Fahrgestell -Nr.: \_\_\_\_\_  
Normal evolution of the type: as from chassis number:

**VF** Liefervariante  
Supply variant

**VO** Ausstattungsvariante  
Option variant

**ER** Berichtigung  
Erratum

Homologation gültig ab: \_\_\_\_\_ - 1 JULI 1985 \_\_\_\_\_ in Gruppe: B  
Homologation valid as from \_\_\_\_\_ in group

Hersteller: AUDI \_\_\_\_\_ Modell und Typ: Sport quattro S1  
Manufacturer \_\_\_\_\_ Model and type

Seite od. Nachtrag Page or ext.	Artikel Art.	Beschreibung Description	
5	333	Trockensumpfschmierung dry sump lubrication	Foto 85 Photo
	605	Achsübersetzung b.) 35/8;37/8; final drive ratio c.) 4,375;4,625;	
7	606	Kardanwelle, ungeteilt prop shaft, unsplit	Foto 86 Photo
08/05 VO	804	Lenkungslager steering brackets	Foto 87 Photo
9	901g	Sonnendach sun roof 1.) Typ Klappe typ flap 2.) Betätigungssystem mechanisch command system mechanical	Foto 88 Photo



*San H. Honey*

Marke AUDI  
Make

Modell Sport quattro S1  
Model

Homologations Nr. B 2 6 4  
Homologation Nr.

Nachtrag Nr. 11-08 VO  
Ext. Nr.

Seite od. Nachtrag Page or ext.	Artikel Art.	Beschreibung Description
7	701 a,b	Federbein verstärkt vorn mit unterschiedlichen Bolzen zur Aufnahme des Querlenkers und zum Ausgleich der Anlenkpunkte Material: Leichtmetall reinforced spring strut with different bolts for support of wishbone and for balancing of attachement points, front material: light alloy Foto 89 Photo
7	701 a,b	Federbein verstärkt hinten mit unterschiedlichen Bolzen zur Aufnahme des Querlenkers und zum Ausgleich der Anlenkpunkte Material: Leichtmetall reinforced spring strut with different bolts for support of wishbone and for balancing of attachement points, rear material : light alloy Foto 90 Photo



Marke AUDI  
Make

Modell Sport quattro S1  
Model

Homologations Nr. B 2 6 4  
Homologation Nr.

Fotos  
Photos

Nachtrag Nr. 11-08 VO  
Ext. Nr.

Foto/Photo 85



Foto/Photo 86



Foto/Photo 87



Foto/Photo 88

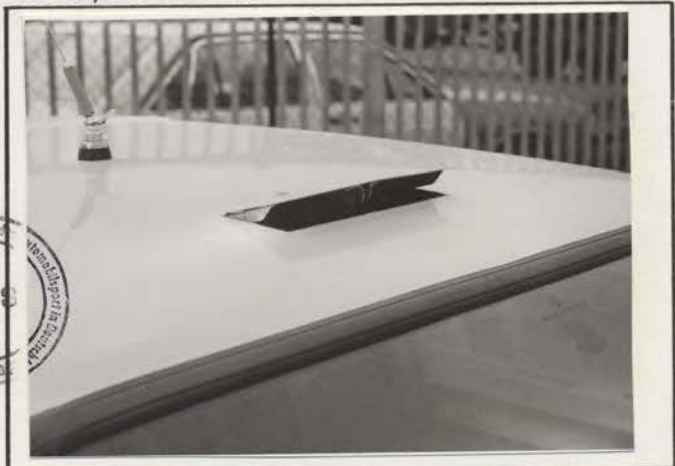

Foto/Photo 89



Foto/Photo 90



FEDERATION INTERNATIONALE  
F.I.S.A.  
DE L'AUTOMOBILE

# FÉDÉRATION INTERNATIONALE DU SPORT AUTOMOBILE

ONS Oberste Nationale Sportkommission für den Automobilsport in Deutschland GmbH

Homologation Nr.

B 2 6 4

Nachtrag Nr.  
Extension Nr.

12-01ES

## Nachtrag zum offiziellen Testblatt der FISA

Form of extension to the official FISA-Homologation

- ET** Normale Weiterentwicklung des Typs: ab Fahrgestell-Nr.: \_\_\_\_\_  
Normal evolution of the type: as from chassis number:
- ES** Sportevolution  
Sporting evolution
- VF** Liefervariante  
Supply variant
- VO** Ausstattungsvariante  
Option variant
- ER** Berichtigung  
Erratum

Homologation gültig ab: - 1 JUL. 1985 in Gruppe: B  
Homologation valid as from in group

Hersteller: AUDI AG Modell und Typ: Sport quattro S1  
Manufacturer Model and type

Seite od. Nachtrag Page or ext.	Artikel Art.	Beschreibung Description
------------------------------------	-----------------	-----------------------------

Foto A2  
photo



Foto B2  
photo



Marke AUDI  
Make

Modell Sport quattro S1  
Model

Homologations Nr. B 264  
Homologation Nr.

**12-01ES**

Fotos  
Photos

Nachtrag Nr. \_\_\_\_\_  
Ext. Nr.

C2

12-01ES  
D2

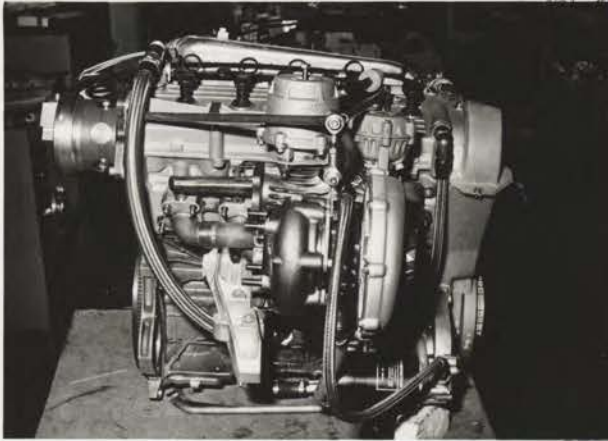

E2

12-01ES  
ONS  
F2

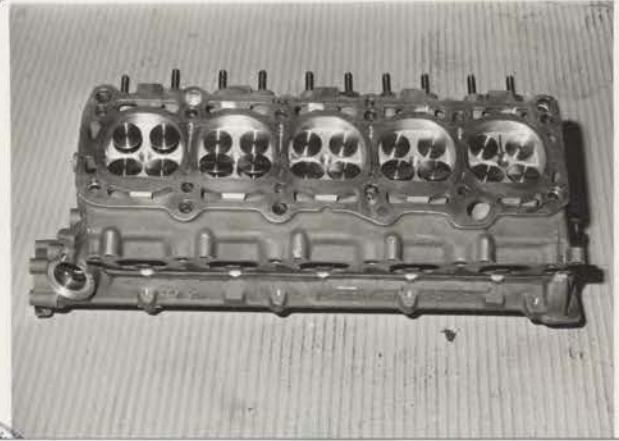

12-01ES  
ONS  
12

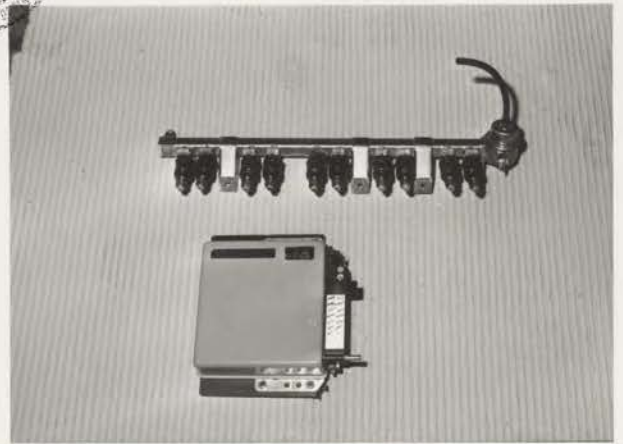

Marke AUDI  
Make

Modell Sport quattro S1  
Model

Homologations Nr. B 2 6 4  
Homologation Nr.

**12-01ES**

Fotos  
Photos

Nachtrag Nr. \_\_\_\_\_  
Ext. Nr.

I2

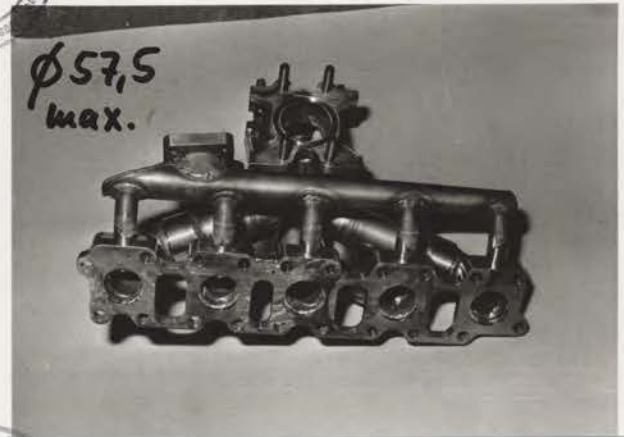
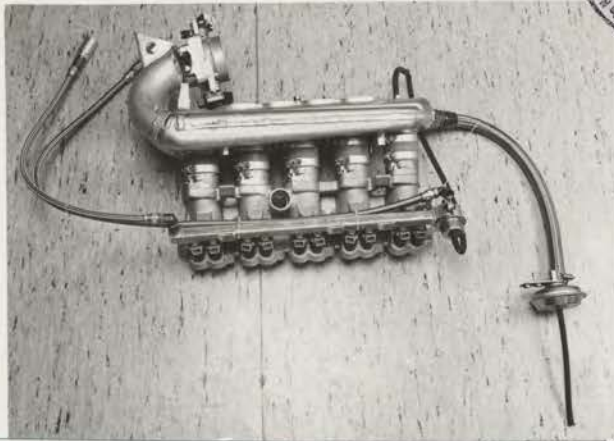

S3



S5

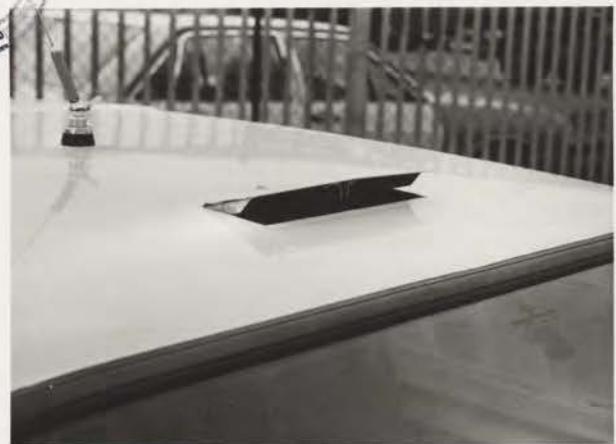



Marke AUDI  
 Make

Modell Sport quattro  
 Model

Homologations Nr. B 264  
 Homologation Nr.

**12-01ES**

Nachtrag Nr. \_\_\_\_\_  
 Ext. Nr.

Seite od. Nachtrag Page or ext.	Artikel Art.	Beschreibung Description
2	202	Länge über alles overall length 4240 mm $\pm$ 1 %
	203	Breite über alles overall width 1860 mm $\pm$ 1 % (Vorderachse/ front axle)
	204	Karosseriebreite width of bodywork a) Vorderradmitte 1860 mm $\pm$ 1 % at front axle b) Hinterradmitte 1860 mm $\pm$ 1 % at rear axle
	209a	Überhang vorne overhang front 1111 mm $\pm$ 1 %
	209b	Überhang hinten overhang rear 905 mm $\pm$ 1 %



Marke AUDI  
Make

Modell Sport quattro S1  
Model

Homologations Nr. B 2 6 4  
Homologation Nr.

**12-01ES**

Nachtrag Nr. \_\_\_\_\_  
Ext. Nr.

Seite od. Nachtrag Page or ext.	Artikel Art.	Beschreibung Description
		MOTOR/ENGINE
		<u>Pleuel/connecting rod</u>
318d		Länge zwischen den Achsen length between the axes 144 mm $\pm$ 0,2 mm
318e		Mindestgewicht minimum weight 530 g
319f		Kurbelwelle/crank shaft
		Durchmesser der Hauptlager diameter of bearings 58 mm $\pm$ 0,2 %
319h		Mindestgewicht/minimum weight 10300 g
320b		Schwungrad/flywheel
		Mindestgewicht minimum weight 3495 g Foto 38 photo
		Mindestgewicht (Automatik) minimum weight (automatic) 930 g Foto 38 a photo
		Ventildeckel modifiziert valve cover modified Foto 39 photo
		Luftansaugkasten mit Filter air induction box with filter Foto 41 photo
		Wasserkühler im Kofferraum radiator in rear trunk Foto 42 photo
		Zusatzwasserkühler links + rechts add. radiator left + right Foto 43 photo
		in Kotflügel in mudguard



Marke AUDI  
Make

Modell Sport quattro S1  
Model

Homologations Nr. B 264  
Homologation Nr.

Fotos  
Photos

Nachtrag Nr. 12-01ES  
Ext. Nr.

Foto/photo 38



Foto/photo 39

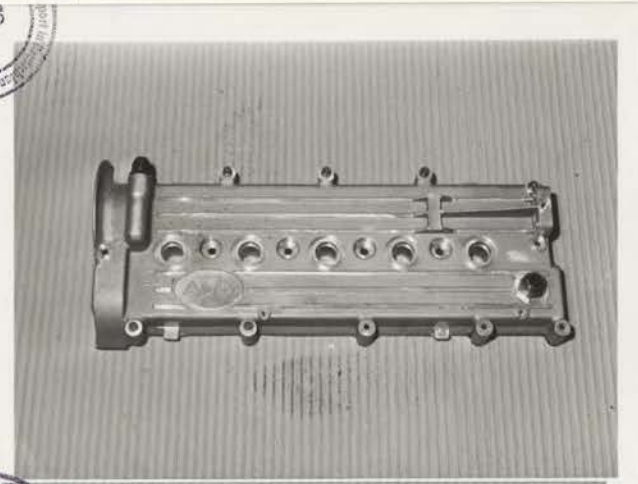

Foto/photo 38 a



Foto/photo 41

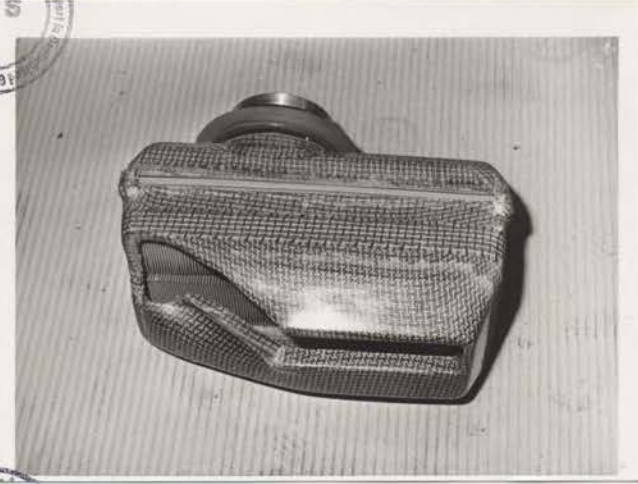

Foto/photo 42



Foto/photo 43



Marke AUDI  
Make

Modell Sport quattro S1  
Model

Homologations Nr. B 264  
Homologation Nr.

Nachtrag Nr. 12-01ES  
Ext. Nr.

Seite od. Nachtrag Page or ext.	Artikel Art.	Beschreibung Description	
		Abstützung für Turbolader und 2 Ventile support for turbo charger and 2 valves	Foto 44 photo
		Wasserausgleichsbehälter an C-holm water expansion tank at C-pillar	Foto 45 photo
03/01ET Foto 16		Zylinderkopf ohne Kraftstoffpumpe cylinderhead without fuel pump	Foto 46 photo
		Kupplungsgehäuse Be- und Entlüftung clutch housing ventilation system	Foto 47 photo
		2. Lichtmaschine im Kofferraum, Antrieb durch Servomotor und Zahnriemen (für Nachtbetrieb) Second generator in rear trunk, with power drive and toothed belt (for night drive)	Foto 48 photo
		Fahrzeug ohne Rückfahrscheinwerfer without reversing light	
		9. Karosserie/bodywork	
		Kastenprofil zur Verstärkung zwischen den Domen hinten, verschweißt bodywork reinforcement between rear strut top mountings, welded	Foto 49 photo



Marke AUDI  
Make

Modell Sport quattro S1  
Model

Homologations Nr. B 264  
Homologation Nr.

**12-01ES**

Fotos  
Photos

Nachtrag Nr. \_\_\_\_\_  
Ext. Nr.

Foto/photo 44

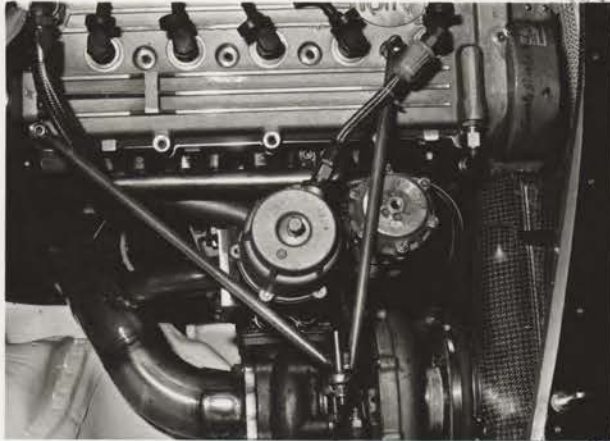

Foto/photo 45



Foto/photo 46



Foto/photo 47



Foto/photo 48



Foto/photo 49



Marke AUDI  
 Make

Modell Sport quattro S1  
 Model

Homologations Nr. B 264  
 Homologation Nr.

**12-01ES**

Nachtrag Nr. \_\_\_\_\_  
 Ext. Nr.

Seite od. Nachtrag Page or ext.	Artikel Art.	Beschreibung Description
4	326e	Steuerung/timing  Max. Ventilhub      Einlaß 11,50 mm      Auslaß 11,50 mm max. valve lift      inlet                      exhaust mit einem Spiel von:/with clearance: 0,30 mm                      0,30 mm
	327	Einlaß: mod. Saugrohr mit Unterdruckbegrenzer      Foto I2 inlet: mod. inlet manifold with vacuum limiter      photo
	327b	Anzahl der Ansaugkrümmerelemente      12 number of manifold elements
	327d	Max. Durchmesser der Ventile      32,2 mm max. diameter of the valves
	327e	Durchmesser des Ventilschaftes      8,0 mm diameter of the valve stem
	327f	Länge des Ventils      107,5 ± 1,5 mm length of the valve
	328	Auslaß/exhaust:
	328d	Material des Auslaßkrümmers      Stahlrohr      Foto J2 material of the manifold      steel pipe      photo



Marke \_\_\_\_\_  
Make

Modell \_\_\_\_\_  
Model

Homologations Nr. \_\_\_\_\_  
Homologation Nr.

12-01ES

Nachtrag Nr. \_\_\_\_\_  
Ext. Nr.

Seite od. Nachtrag Page or ext.	Artikel Art.	Beschreibung Description
5	328e	Max. Durchmesser der Ventile 28,2mm max. diameter of the valves
	328f	Durchmesser des Ventilschaftes 8mm diameter of the valve stem
	328g	Länge des Ventils 108,75 <sup>±</sup> 1,5mm
	502	Kupplung/clutch
	602c	Anzahl der Scheiben/number of plates: 2
	603	Getriebe/gear box Fotos/Photos S3,S4,S5

e) Übersetzungen  
Ratios

	Handschaltung Manual			Automatik Automatic			Zusätzl. Getriebe Additional G.E.		
	Über- setzungen ratio	Anzahl der Zähne number of teeth	synchro.	Über- setzungen ratio	Anzahl der Zähne number of teeth	synchro.	Über- setzungen ratio	Anzahl der Zähne number of teeth	synchro.
1	3,111	28:9	X	3,000	36:12	X	3,500	28:8	X
2	2,273	25:11	X	2,000	32:16	X	2,273	25:11	X
3	1,706	29:17	X	1,526	29:19	X	1,706	29:17	X
4	1,318	29:22	X	1,167	28:24	X	1,318	29:22	X
5	0,962	25:26	X	0,963	26:27	X	1,040	26:25	X
6	—	—		—	—		0,889	24:27	X
Rück- wärts R	3,455	38:11		2,875	46:16	X	3,455	38:11	

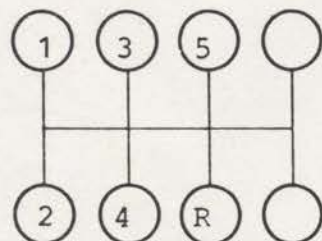

f) Schalt-Schema  
Gear change gate

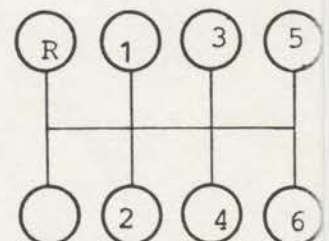

603c Marke / make : Porsche DK-Automat

Marke AUDI  
Make

Modell Sport quattro S1  
Model

Homologations Nr. B 2 6 4  
Homologation Nr.

Nachtrag Nr. 12 - 0 1 ES  
Ext. Nr.

Seite od. Nachtrag Page or ext.	Artikel Art.	Beschreibung Description
		<p>modifizierte Getriebetunnel und geänderte Schaltbetätigung modified transmission tunnel and modified gear shift mechanism</p> <p>Belüftung durch Außenspiegel links + rechts ventilation through mirror left + right</p> <p>neues Frontteil mit längenveränderlicher, starrer Kunststoffkante new frontpart with stiff plastic edge (length adjustable)</p>

Foto 50  
photo

Foto 51

Foto 52  
photo





Marke AUDI  
Make

Modell Sport quattro S1  
Model

Homologations Nr. B 2 6 4  
Homologation Nr.

Fotos  
Photos

Nachtrag Nr. 12-01ES  
Ext. Nr.

Foto/photo 50



Foto/photo 51



Foto/photo 52



Marke AUDI  
Make

Modell Sport quattro S1  
Model

Homologations Nr. B 264  
Homologation Nr.

**12-01ES**

Nachtrag Nr. \_\_\_\_\_  
Ext. Nr.

Seite od. Nachtrag Page or ext.	Artikel Art.	Beschreibung Description
		Armaturenbrett dash bord
		Foto X2 photo
03/01ET S. 18		Ohne obere Querstrebe without top cross strut
		Foto 53 photo
		Frontteil komplett abnehmbar front part complete detachable
		Foto 54 photo
		Heckklappe durchbrochen, abnehmbar boot lid with grill holes, detachable
		Foto 55 photo
		Durchbrüche in Kotflügeln mit Luftführung links + rechts grill holes in mudguards with air ducts left and right
		Foto 56 + 57 photo



Marke AUDI  
Make

Modell Sport quattro S1  
Model

Homologations Nr. B 264  
Homologation Nr.

**12-01ES**

Fotos  
Photos

Nachtrag Nr. \_\_\_\_\_  
Ext. Nr.

Foto/photo X2

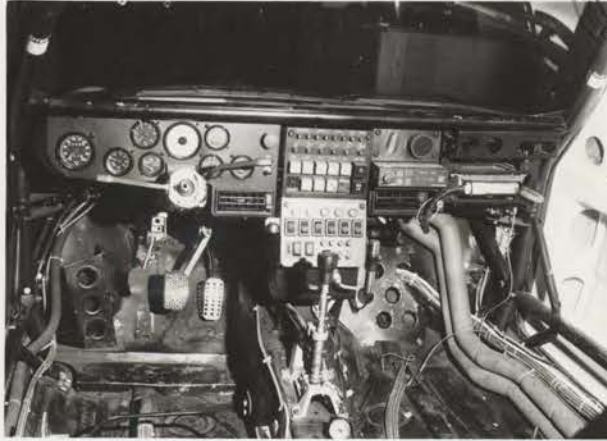

Foto/photo 53

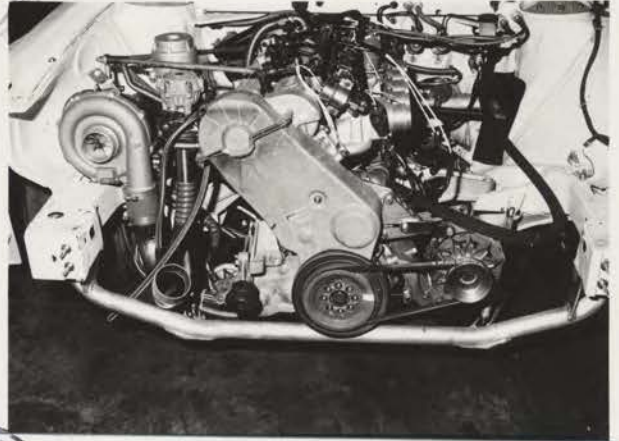

Foto/photo 54



Foto/photo 55



Foto/photo 56



Foto/photo 57



Marke AUDI  
Make

Modell Sport quattro S1  
Model

Homologations Nr. B 2 6 4  
Homologation Nr.

**12-01ES**

Nachtrag Nr. \_\_\_\_\_  
Ext. Nr.

Seite od. Nachtrag Page or ext.	Artikel Art.	Beschreibung Description
		Heckfenster klappbar rear window
		Wagenheberaufnahme jack supports
		Kühlluftführung und Luftleitteil verstellbar cooling air duct and air guiding sheet adjustable
		Heckflügel verstellbar rear wing adjustable
		Klappe durch Seitenteil links lid in bodywork left
		Klappe in Seitenteil rechts lid in bodywork right



Marke AUDI  
Make

Modell Sport quattro S1  
Model

Homologations Nr. B 2 6 4  
Homologation Nr.

**12-01ES**

Fotos  
Photos

Nachtrag Nr. \_\_\_\_\_  
Ext. Nr.

Foto/photo 58



Foto/photo 59



Foto/photo 60



Foto/photo 61



Foto/photo 62

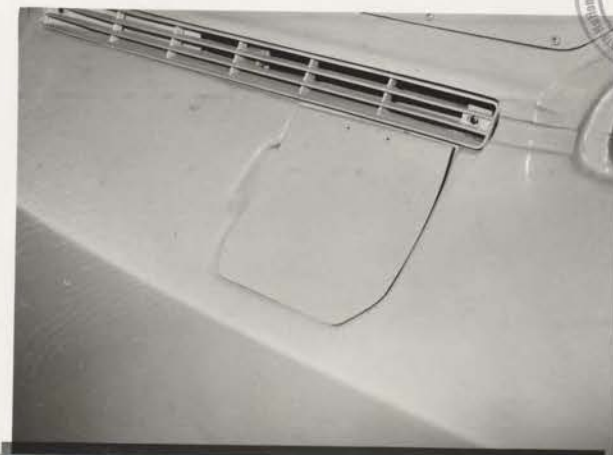

Foto/photo 63

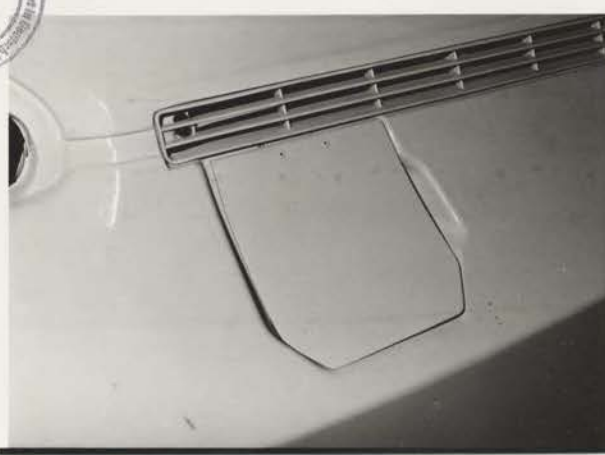

Marke AUDI  
Make

Modell Sport quattro S1  
Model

Homologations Nr. B 264  
Homologation Nr.

**12-01ES**

Nachtrag Nr. \_\_\_\_\_  
Ext. Nr.

Seite od. Nachtrag Page or ext.	Artikel Art.	Beschreibung Description
03/01ET ET 11	902	Fotos 20, 21, 22, 23 entfallen photos deleted  h/i: Seitenscheiben hinten herausnehmbar rear side window removable  Karosserieänderungen bodywork modifications Foto 64 - 81 photo
03/01ET ET 15	334	f1: Bypassventil/relief valve f2: manuell-pneumatisch (Handrad), pneumatisch-elektrisch manuell-pneumatical (hand wheel), pneumatical-electrical
ET 16		h: ohne Wassereinspritzung without water injection  Abblasventil/relief valve Foto 02 photo  Umluftventil/circulating air valve (wahlweise/optional) Foto 03 photo  Umluftsystem/circulating air system Foto 04 photo



Marke AUDI  
Make

Modell Sport quattro S1  
Model

Homologations Nr. B 2 6 4  
Homologation Nr.

Fotos  
Photos

Nachtrag Nr. 12-01ES  
Ext. Nr.

Foto/photo 64



Foto/photo 65



Foto/photo 66



Foto/photo 67



Foto/photo 68



Foto/photo 69



FEDERATION INTERNATIONALE  
F.I.S.A.  
DE L'AUTOMOBILE

Marke AUDI  
Make

Modell Sport quattro S1  
Model

Homologations Nr. B 264  
Homologation Nr.

**12-01ES**

Fotos  
Photos

Nachtrag Nr. \_\_\_\_\_  
Ext. Nr.

Foto/photo 70



Foto/photo 71



Foto/photo 72



Foto/photo 73

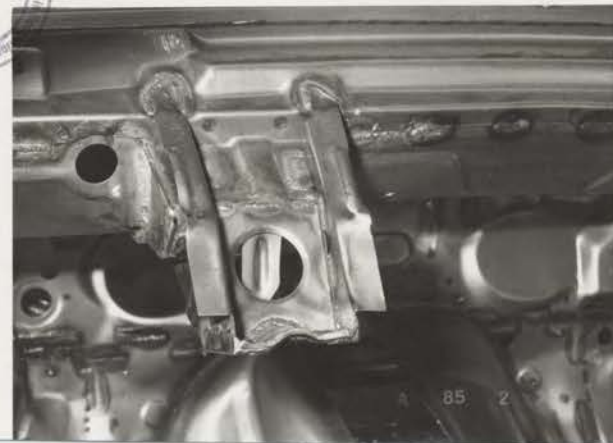

Foto/photo 74



Foto/photo 75

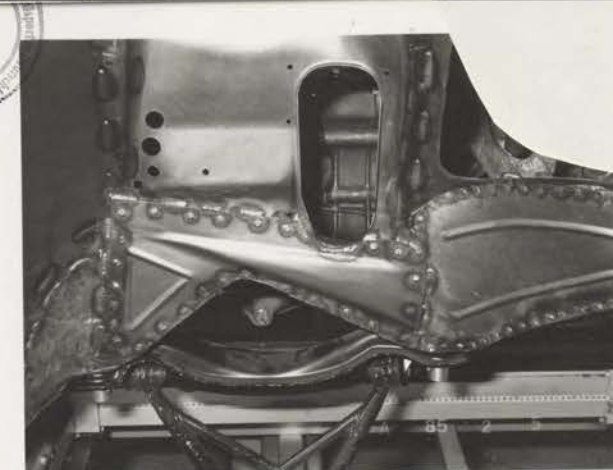



Marke AUDI  
Make

Modell Sport quattro S1  
Model

Homologations Nr. B 264  
Homologation Nr.

**12-01ES**

Fotos  
Photos

Nachtrag Nr. \_\_\_\_\_  
Ext. Nr.

Foto/photo 76

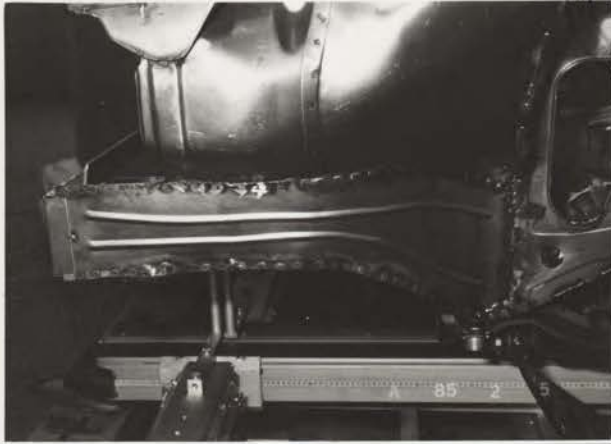

Foto/photo 77



Foto/photo 78



Foto/photo 79

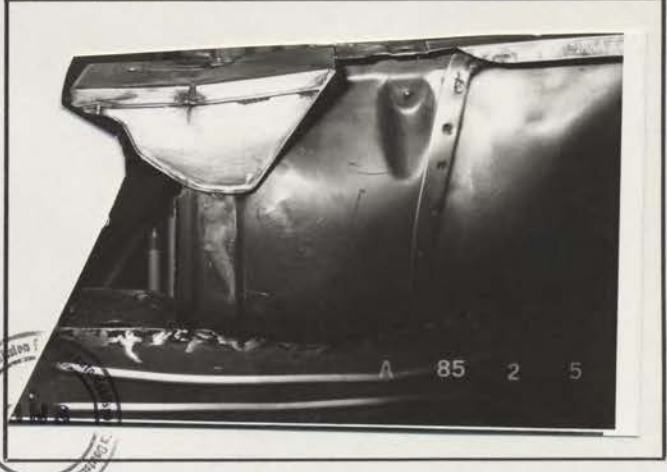

Foto/photo 80



Foto/photo 81



Marke AUDI  
Make

Modell Sport quattro  
Model

Homologations Nr. B 264  
Homologation Nr.

**12-01ES**

Fotos  
Photos

Nachtrag Nr. \_\_\_\_\_  
Ext. Nr.

Foto/photo 02



Foto/photo 03



Foto/photo 04

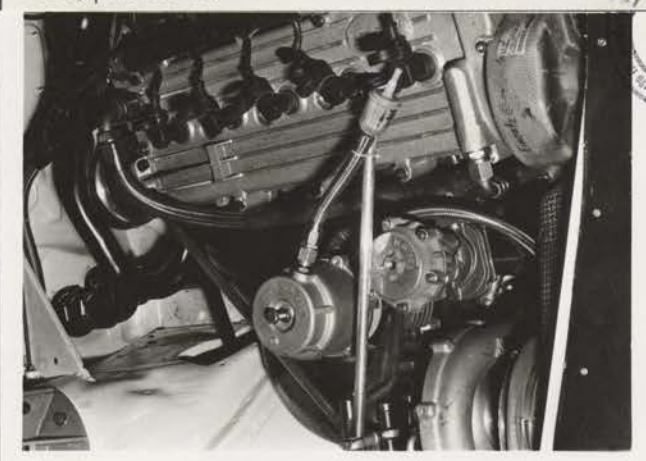

Marke AUDI  
Make

Modell Sport quattro S1  
Model

Homologation Nr. B 264  
Homologation N°

12-01ES

**Zeichnungen**  
Drawings

**Motor**  
Engine

I. Einlaßöffnungen im Ansaugkrümmer  
Cylinderhead inlet ports, manifold side

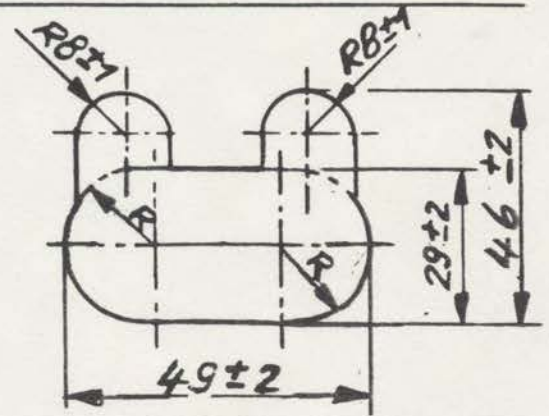

II. Einlaßöffnungen im Zylinderkopf  
Inlet manifold ports, cylinderhead side

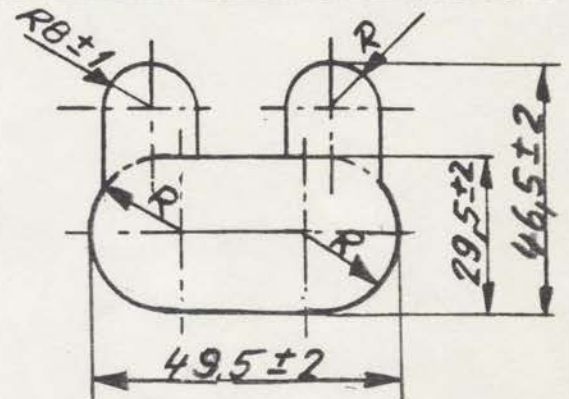

III. Auslaßöffnungen im Auspuffkrümmer  
Cylinderhead exhaust ports, manifold side



IV. Auslaßöffnungen im Zylinderkopf  
Exhaust manifold ports, cylinderhead side





Marke AUDI  
Make

Modell Sport quattro S1  
Model

Homologations Nr. B 2 6 4  
Homologation Nr.

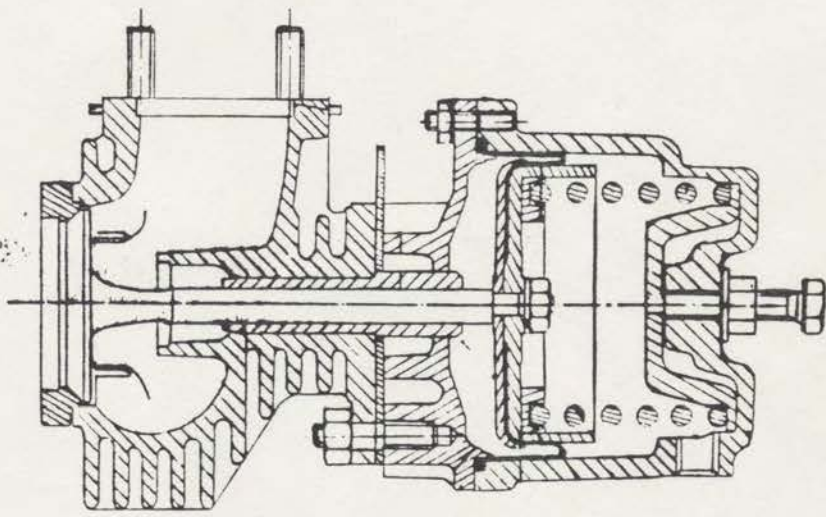
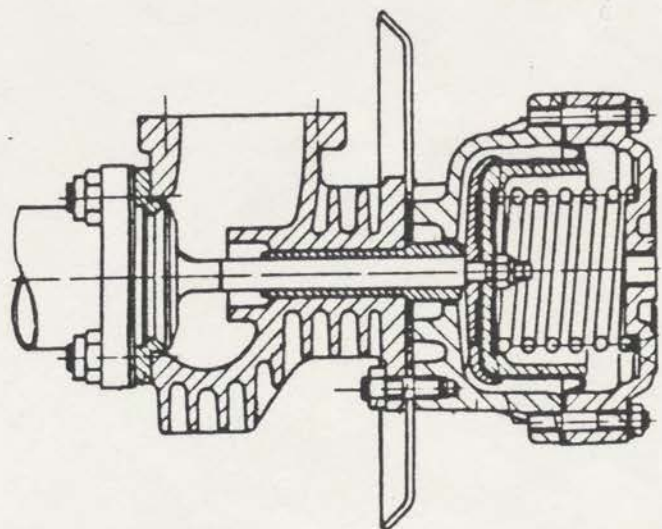
Nachtrag Nr. 12-01ES  
Ext. Nr.

Seite od. Nachtrag Page or ext.	Artikel Art	Beschreibung Description
		<p data-bbox="454 436 755 526">1. Abblaseventil Relief valve</p>  <p data-bbox="462 1366 933 1467">2. Umluftventil circulating air valve</p>  

Homologation Nr.

B 264

Nachtrag Nr.  
Extension Nr.

**13 - 03 ER**

**Nachtrag zum offiziellen Testblatt der FISA**

Form of extension to the official FISA-Homologation

- ET** Normale Weiterentwicklung des Typs: ab Fahrgestell-Nr.: \_\_\_\_\_  
Normal evolution of the type: as from chassis number:
- VF** Liefervariante  
Supply variant
- VO** Ausstattungsvariante  
Option variant
- ER** Berichtigung  
Erratum

**- 1 JAN. 1986**

Homologation gültig ab: \_\_\_\_\_ in Gruppe: **B**  
Homologation valid as from: \_\_\_\_\_ in group

Hersteller: **AUDI AG** Modell und Typ: **Sport quattro S1**  
Manufacturer: \_\_\_\_\_ Model and type: \_\_\_\_\_

Seite od. Nachtrag Page or ext	Artikel Art.	Beschreibung Description
-----------------------------------	-----------------	-----------------------------

Ladeluftkühler/intercooler

Anbringungsort: vorne hinter Grill  
location: front behind grill

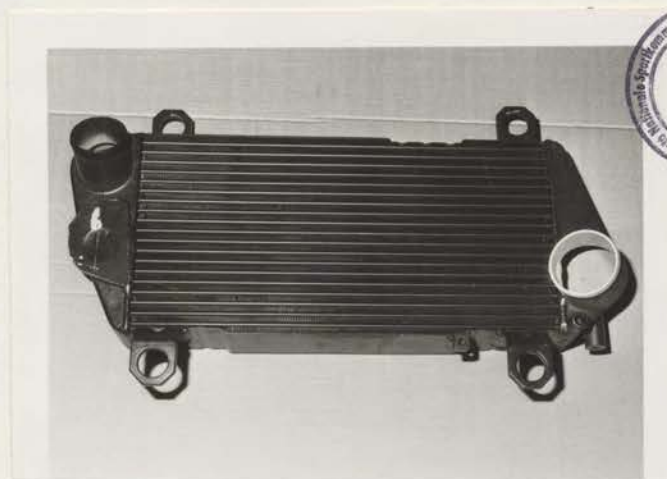

*[Handwritten signature]*

Homologation Nr.

B 264

Nachtrag Nr.  
Extension Nr.

**13-03 ER**

**Nachtrag zum offiziellen Testblatt der FISA**

Form of extension to the official FISA-Homologation

- ET** Normale Weiterentwicklung des Typs: ab Fahrgestell -Nr.: \_\_\_\_\_  
Normal evolution of the type, as from chassis number:
- VF** Liefervariante  
Supply variant
- VO** Ausstattungsvariante  
Option variant
- ER** Berichtigung  
Erratum

Homologation gültig ab: \_\_\_\_\_ in Gruppe: B  
Homologation valid as from: \_\_\_\_\_ in group

Hersteller: AUDI AG Modell und Typ: Sport quattro S1  
Manufacturer: \_\_\_\_\_ Model and type

Seite od. Nachtrag Page or ext.	Artikel Art.	Beschreibung Description
03/01 ET		<p>Ladeluftkühler/intercooler</p> <p>Anbringungsort: vorne hinter Grill location: front behind grill</p> <div data-bbox="495 1668 1161 2139" style="text-align: center;">  </div>



Homologation Nr.

B 264

Nachtrag Nr.  
Extension Nr.

**13 - 03 ER**

**Nachtrag zum offiziellen Testblatt der FISA**

Form of extension to the official FISA-Homologation

- ET** Normale Weiterentwicklung des Typs: ab Fahrgestell -Nr.: \_\_\_\_\_  
Normal evolution of the type: as from chassis number:
- VF** Liefervariante  
Supply variant
- VO** Ausstattungsvariante  
Option variant
- ER** Berichtigung  
Erratum

Homologation gültig ab: \_\_\_\_\_ in Gruppe:   B    
Homologation valid as from in group

Hersteller:   AUDI AG   Modell und Typ:   Sport quattro S1    
Manufacturer: Model and type

Seite od. Nachtrag Page or ext.	Artikel Art.	Beschreibung Description
12/01 ES		<p>Ladeluftkühler/intercooler</p> <p>Anbringungsort: vorne hinter Grill location: front behind grill</p> <div data-bbox="500 1691 1166 2168" style="text-align: center;">  </div>

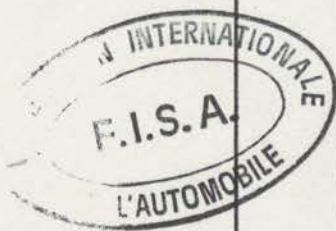

# FÉDÉRATION INTERNATIONALE DU SPORT AUTOMOBILE

ONS Oberste Nationale Sportkommission für den Automobilsport in Deutschland GmbH

Homologation Nr.

B 264

Nachtrag Nr.  
Extension Nr.

14 - 04 ER

## Nachtrag zum offiziellen Testblatt der FISA

Form of extension to the official FISA-Homologation

**ET** Normale Weiterentwicklung des Typs: ab Fahrgestell -Nr.: \_\_\_\_\_  
Normal evolution of the type, as from chassis number.

**VF** Liefervariante  
Supply variant

**VO** Ausstattungsvariante  
Option variant

**ER** Berichtigung  
Erratum

Homologation gültig ab: \_\_\_\_\_  
Homologation valid as from

- 1 JAN. 1986

in Gruppe: B  
in group

Hersteller: AUDI AG  
Manufacturer

Modell und Typ: Sport quattro S1  
Model and type

Seite od. Nachtrag Page or ext.	Artikel Art.	Beschreibung Description
12/04 ES		Heckflügel, max. 85 % der Gesamtbreite = 1581 + 1 % mm rear wing, max 85 % of overall width = 1581 + 1 % mm

*Signature*



Foto 61





# FÉDÉRATION INTERNATIONALE DU SPORT AUTOMOBILE

ONS Oberste Nationale Sportkommission für den Automobilsport in Deutschland GmbH

Homologation Nr.

B 264

Nachtrag Nr.  
Extension Nr.

**15-05ER**

## Nachtrag zum offiziellen Testblatt der FISA

Form of extension to the official FISA-Homologation

- ET** Normale Weiterentwicklung des Typs: ab Fahrgestell-Nr.: \_\_\_\_\_  
Normal evolution of the type as from chassis number:
- VF** Liefervariante  
Supply variant
- VO** Ausstattungsvariante  
Option variant
- ER** Berichtigung  
Erratum

**- 1 AVR. 1986**

Homologation gültig ab: \_\_\_\_\_ in Gruppe: B  
Homologation valid as from: \_\_\_\_\_ in group

Hersteller: AUDI AG Modell und Typ: Sport quattro S1  
Manufacturer: \_\_\_\_\_ Model and type

Seite od. Nachtrag Page or ext.	Artikel Art.	Beschreibung Description																																																															
03/01 ET ET 6	603	<p>zusätzliches Getriebe/additional gear box Nur für ET gültig/valid for ET only</p> <table border="1"> <thead> <tr> <th></th> <th colspan="3">falsch/wrong</th> <th colspan="3">richtig/right</th> </tr> <tr> <th></th> <th>Zusätzl. Getriebe Über- setzungen ratio</th> <th>Anzahl der Zähne number of teeth</th> <th>synchr. synchron</th> <th>Zusätzl. Getriebe Über- setzungen ratio</th> <th>Anzahl der Zähne number of teeth</th> <th>synchr. synchron</th> </tr> </thead> <tbody> <tr> <td><del>1</del></td> <td><del>2,700</del></td> <td><del>27:10</del></td> <td><del>x</del></td> <td><b>3,500</b></td> <td><b>28 : 8</b></td> <td><b>x</b></td> </tr> <tr> <td><del>2</del></td> <td><del>2,083</del></td> <td><del>25:12</del></td> <td><del>x</del></td> <td><b>2,273</b></td> <td><b>25 : 11</b></td> <td><b>x</b></td> </tr> <tr> <td><del>3</del></td> <td><del>1,706</del></td> <td><del>29:17</del></td> <td><del>x</del></td> <td><b>1,706</b></td> <td><b>29 : 17</b></td> <td><b>x</b></td> </tr> <tr> <td><del>4</del></td> <td><del>1,426</del></td> <td><del>30:21</del></td> <td><del>x</del></td> <td><b>1,318</b></td> <td><b>29 : 22</b></td> <td><b>x</b></td> </tr> <tr> <td><del>5</del></td> <td><del>1,21</del></td> <td><del>28:23</del></td> <td><del>x</del></td> <td><b>1,040</b></td> <td><b>26 : 25</b></td> <td><b>x</b></td> </tr> <tr> <td><del>6</del></td> <td><del>1,040</del></td> <td><del>26:25</del></td> <td><del>x</del></td> <td><b>0,889</b></td> <td><b>24 : 27</b></td> <td><b>x</b></td> </tr> <tr> <td>Rückwärts</td> <td>3,455</td> <td>38:11</td> <td></td> <td><b>3,455</b></td> <td><b>38 : 11</b></td> <td></td> </tr> </tbody> </table>		falsch/wrong			richtig/right				Zusätzl. Getriebe Über- setzungen ratio	Anzahl der Zähne number of teeth	synchr. synchron	Zusätzl. Getriebe Über- setzungen ratio	Anzahl der Zähne number of teeth	synchr. synchron	<del>1</del>	<del>2,700</del>	<del>27:10</del>	<del>x</del>	<b>3,500</b>	<b>28 : 8</b>	<b>x</b>	<del>2</del>	<del>2,083</del>	<del>25:12</del>	<del>x</del>	<b>2,273</b>	<b>25 : 11</b>	<b>x</b>	<del>3</del>	<del>1,706</del>	<del>29:17</del>	<del>x</del>	<b>1,706</b>	<b>29 : 17</b>	<b>x</b>	<del>4</del>	<del>1,426</del>	<del>30:21</del>	<del>x</del>	<b>1,318</b>	<b>29 : 22</b>	<b>x</b>	<del>5</del>	<del>1,21</del>	<del>28:23</del>	<del>x</del>	<b>1,040</b>	<b>26 : 25</b>	<b>x</b>	<del>6</del>	<del>1,040</del>	<del>26:25</del>	<del>x</del>	<b>0,889</b>	<b>24 : 27</b>	<b>x</b>	Rückwärts	3,455	38:11		<b>3,455</b>	<b>38 : 11</b>	
	falsch/wrong			richtig/right																																																													
	Zusätzl. Getriebe Über- setzungen ratio	Anzahl der Zähne number of teeth	synchr. synchron	Zusätzl. Getriebe Über- setzungen ratio	Anzahl der Zähne number of teeth	synchr. synchron																																																											
<del>1</del>	<del>2,700</del>	<del>27:10</del>	<del>x</del>	<b>3,500</b>	<b>28 : 8</b>	<b>x</b>																																																											
<del>2</del>	<del>2,083</del>	<del>25:12</del>	<del>x</del>	<b>2,273</b>	<b>25 : 11</b>	<b>x</b>																																																											
<del>3</del>	<del>1,706</del>	<del>29:17</del>	<del>x</del>	<b>1,706</b>	<b>29 : 17</b>	<b>x</b>																																																											
<del>4</del>	<del>1,426</del>	<del>30:21</del>	<del>x</del>	<b>1,318</b>	<b>29 : 22</b>	<b>x</b>																																																											
<del>5</del>	<del>1,21</del>	<del>28:23</del>	<del>x</del>	<b>1,040</b>	<b>26 : 25</b>	<b>x</b>																																																											
<del>6</del>	<del>1,040</del>	<del>26:25</del>	<del>x</del>	<b>0,889</b>	<b>24 : 27</b>	<b>x</b>																																																											
Rückwärts	3,455	38:11		<b>3,455</b>	<b>38 : 11</b>																																																												
30/01 ET ET 3	318d	<p>Länge/length 144 mm anstelle von/instead of 140 mm</p>																																																															



# FÉDÉRATION INTERNATIONALE DU SPORT AUTOMOBILE

ONS Oberste Nationale Sportkommission für den Automobilsport in Deutschland GmbH

Homologation Nr.

B - 2 6 4

Nachtrag Nr.  
Extension Nr.

16 / 06 ER

## Nachtrag zum offiziellen Testblatt der FISA

Form of extension to the official FISA-Homologation

**ET** Normale Weiterentwicklung des Typs: ab Fahrgestell -Nr.: \_\_\_\_\_  
Normal evolution of the type: as from chassis number:

**VF** Liefervariante  
Supply variant

**VO** Ausstattungsvariante  
Option variant

**ER** Berichtigung  
Erratum

**- 1 OCT. 1986**

Homologation gültig ab: \_\_\_\_\_ in Gruppe: **B**  
Homologation valid as from \_\_\_\_\_ in group

Hersteller: **AUDI AG** Modell und Typ: **Sport quattro S 1**  
Manufacturer \_\_\_\_\_ Model and type \_\_\_\_\_

Seite od. Nachtrag Page or ext.	Artikel Art.	Beschreibung Description
12/01 ES ES 29 ES 30 Foto 52		<p>falsch / wrong: neues Frontteil mit längenveränderlicher, <u>starrer</u> Kunststoffkante new frontpart with <u>stiff</u> plastic edge (length adjustable)</p> <p>richtig / right: neues Frontteil mit längenveränderlicher Kunststoff- kante new frontpart with plastic edge (length adjustable)</p>



*[Handwritten signature]*



# FEDERATION INTERNATIONALE DU SPORT AUTOMOBILE

Homologation N°

B - 264

Extension N°

1,7 / 07 ER

FICHE D'EXTENSION A L'HOMOLOGATION OFFICIELLE FISA  
FORM OF EXTENSION TO THE OFFICIAL FISA HOMOLOGATION

- ES** Evolution sportive du type / Sporting evolution of the type
- ET** Evolution normale du type / Normal evolution of the type
- VF** Variante de fourniture / Supply variant
- VO** Variante option / Option variant
- ER** Errata / Erratum

Homologation valable dès le \_\_\_\_\_ en groupe \_\_\_\_\_  
Homologation valid as from 1er Janvier 1988 in group B

Constructeur AUDI Modèle et type Sport Quattro S1  
Manufacturer \_\_\_\_\_ Model and type \_\_\_\_\_

Page ou ext. Page or ext.	Art. Art.	Description Description
		<p>Suite au changement du coefficient de suralimentation porté de (1.4) à (1.7) à partir du 1er Janvier 1988 :</p> <p><u>Articles 103 et 307b</u> :            2134 x 1.7 = 3627.8</p> <p><u>Article 307c</u> :                    2166 x 1.7 = 3682.2</p> <p><u>Article 315</u> :                      79.9</p> <p>Pour l'extension 03/01 ET :</p> <p><u>Articles 103 et 307b</u> :            2110 x 1.7 = 3587</p> <p><u>Article 307c</u> :                    2142 x 1.7 = 3641.4</p>



*[Handwritten signature]*