



FEDERATION INTERNATIONALE DU SPORT AUTOMOBILE

C2.21

FICHE D'HOMOLOGATION POUR MOTEUR DE VOITURE DE TOURISME (Classe II) HOMOLOGATION FORM FOR TOURING CAR ENGINE (Class II)

Constructeur AUDI AG Modèle et type Audi R4 2,0l 16V
 Manufacturer Model and type

Homologation valable à partir du
 Homologation valid as from

01 AVR. 1994

**MOTEUR (version standard)
 ENGINE (standard version)**

Cycle Otto 4-Takt / Otto 4-stroke

Nombre et disposition des cylindres 4 in Reihe / 4 in line
 Number and layout of the cylinders

Mode de refroidissement Flüssigkeitskühlung / liquid cooling
 Cooling system

| | | | | | | |
|--------------------|----------|------------|-----------------|--------|-------------|-----------------|
| Cylindrée: | Unitaire | <u>496</u> | cm ³ | Totale | <u>1984</u> | cm ³ |
| Cylinder capacity: | Unitary | | | Total | | |

Matériau du bloc cylindres Grauguß / cast iron
 Cylinder block material

Vilebrequin :
 Crankshaft :

Matériau Stahl / steel
 Material

Type de paliers Gleitlager / friction bearings
 Type of bearings

Bielles :
 Connecting rods :

Matériau Stahl / steel
 Material

Arbres à cames :
 Camshafts :

Nombre 2
 Number

Emplacement obenliegend / overhead
 Location

FEDERATION INTERNATIONALE
 DE L'AUTOMOBILE
 8, Place de la Concorde, 8
 75008 PARIS

Marque / Make Audi

Modèle / Model Audi R4 2,0l 16V

C2-21

Culasse : Cylinder head :

Nombre / Number 1

Système de commande des soupapes / Type of valve operation hydraulisch / hydraulic

Angle entre axe de la soupape d'admission et axe de la soupape d'échappement / Angle between inlet valve axle and exhaust valve axle 25°

Admission / Inlet : Nombre de soupapes par cylindre / Number of valves per cylinder 2

Echappement / Exhaust : Nombre de soupapes par cylindre / Number of valves per cylinder 2

Système de refroidissement / Cooling system : Mode de refroidissement / Cooling type Flüssigkeitskühlung / liquid cooling

PHOTOS

Profil droit du moteur complet déposé / Right hand view of complete dismantled engine

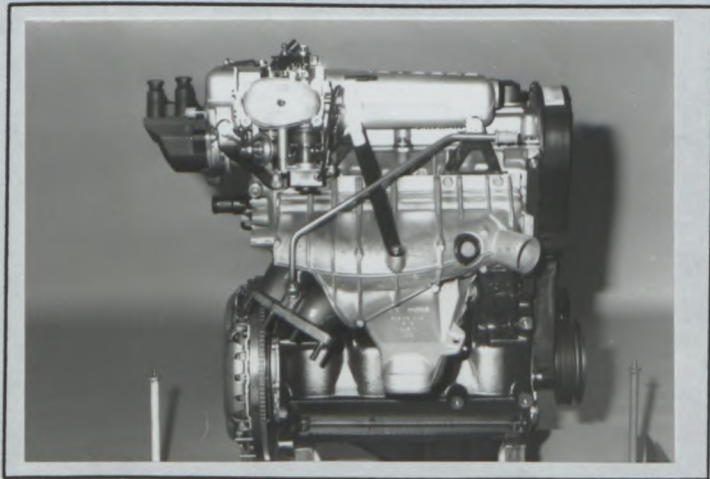

Profil gauche du moteur complet déposé / Left hand view of complete dismantled engine

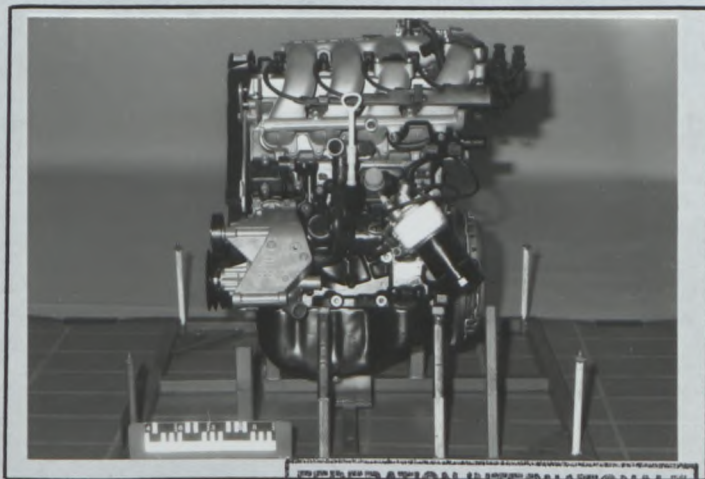

Culasse nue vue de dessus / Bare cylinder head seen from above

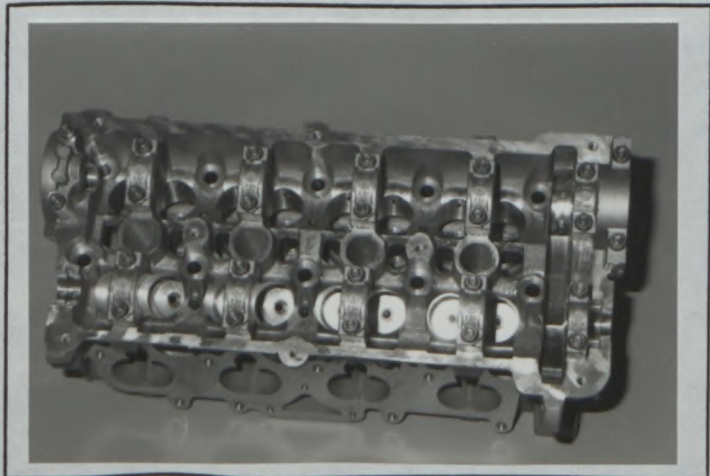

Culasse nue vue de dessous / Bare cylinder head seen from below

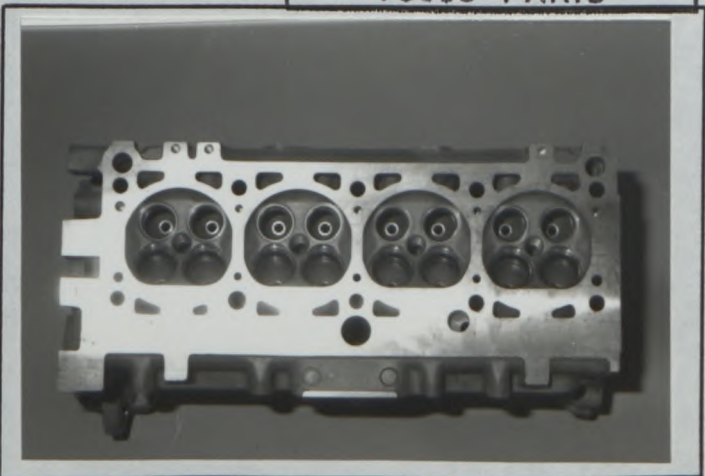

FEDERATION INTERNATIONALE DE L'AUTOMOBILE 8, Place de la Concorde, 8 75008 PARIS

Marque Audi
 Make _____

Modèle Audi R4 2,0l 16V
 Model _____

C2-21

Profil droit de culasse nue
 Right hand view of bare cylinder head

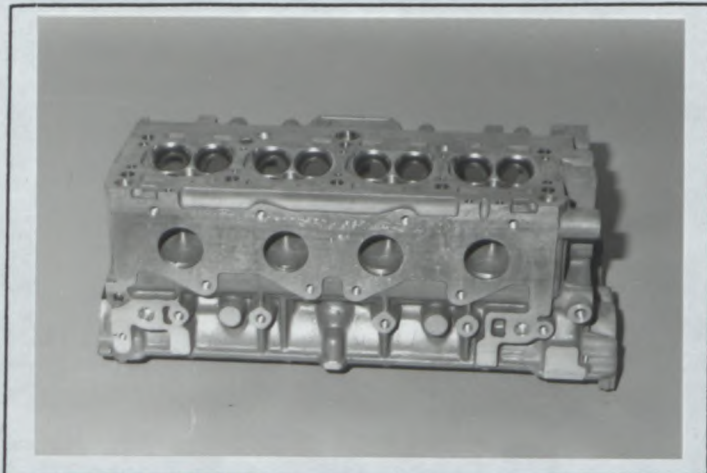

Profil gauche de culasse nue
 Left hand view of bare cylinder head

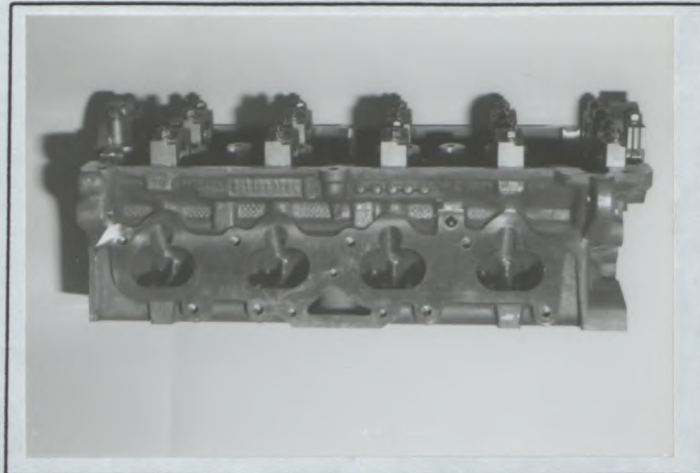

Bloc nu vu de dessus
 Bare block seen from above

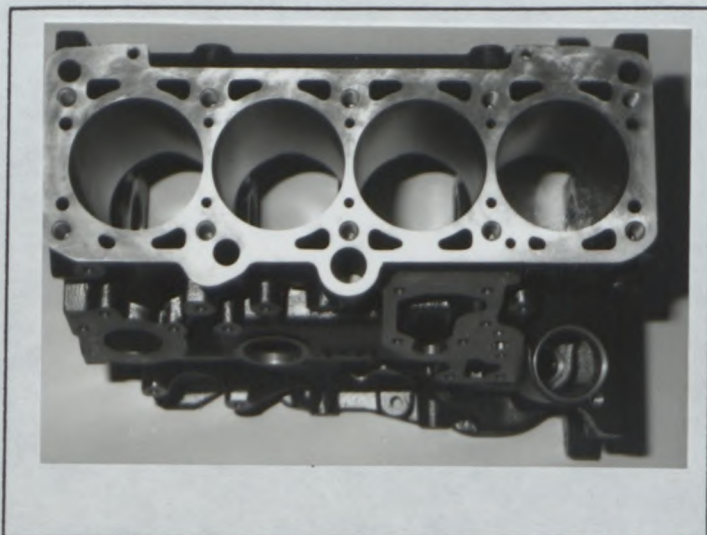

Bloc nu vu de dessous
 Bare block seen from below

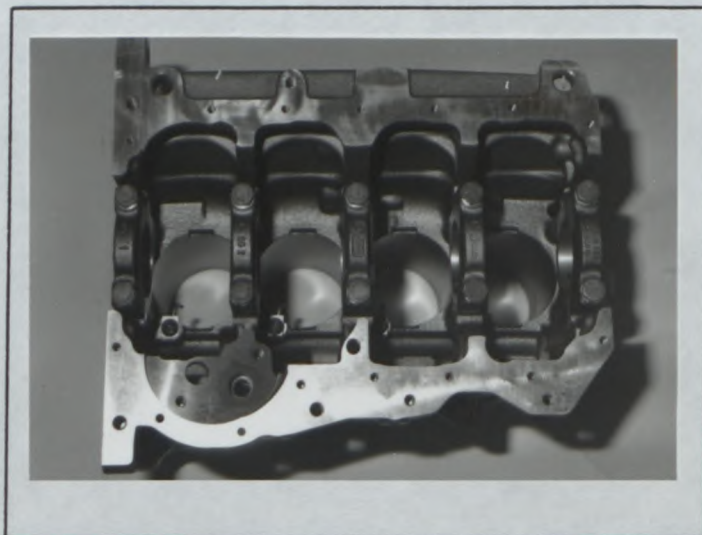

Profil droit du bloc nu
 Right hand view of bare block

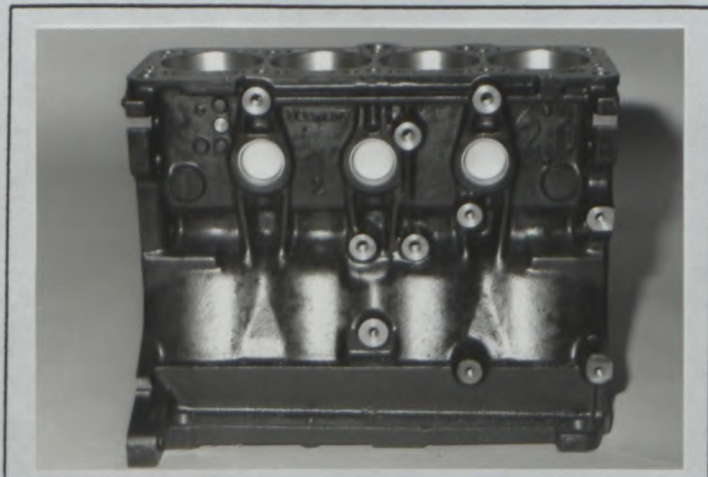

Profil gauche du bloc nu
 Left hand view of bare block

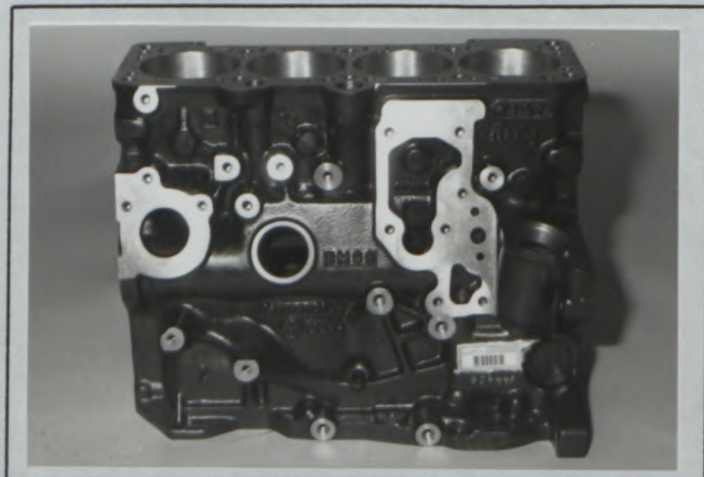

FEDERATION INTERNATIONALE
 DE L'AUTOMOBILE
 8, Place de la Concorde, 8
 75008 PARIS