

# FÉDÉRATION INTERNATIONALE DE L'AUTOMOBILE

FICHE D'HOMOLOGATION CONFORME A L'ANNEXE J DU CODE SPORTIF INTERNATIONAL  
POUR LES VOITURES DES GROUPES 1 A 5

BOOK OF RECOGNITION IN ACCORDANCE WITH APPENDIX J TO THE INTERNATIONAL  
SPORTING CODE FOR CARS OF GROUPS 1 TO 5

Constructeur/Manufacturer SAAB-SCANIA AB Modèle / Model SAAB 99 SEDAN TURBO  
Cylindrée / Cylinder capacity 1985 (2780)  
Constructeur du châssis / Chassis Manufacturer SAAB-SCANIA AB  
Constructeur du moteur / Engine Manufacturer SAAB-SCANIA AB  
Homologation valable à partir du / Recognition valid as from -1 AVR. 1979

Modèle homologué en groupe 2 Numéro d'homologation 1 6 9 5  
Model recognized in group

Photo A : voiture vue de 3/4 AV  
Photo A : 3/4 view of car from front

Photo B : voiture vue de 3/4 AR  
Photo B : 3/4 view of car from rear

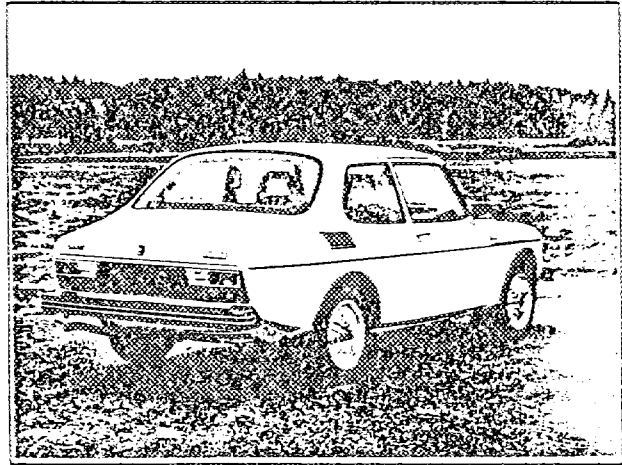
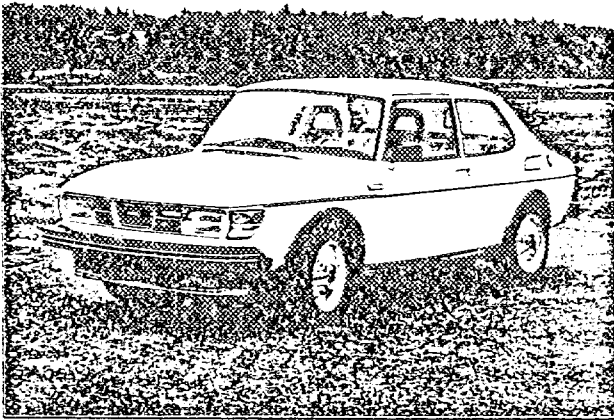

## CARACTÉRISTIQUES GÉNÉRALES / GENERAL CHARACTERISTICS :

- 1) Mode de construction : construction séparée / monocoque.  
Type of car construction : separate / unitary construction.
- 2) Matériau du châssis Steel Matériau de la carrosserie Steel  
Material of chassis Material of coachwork
- 3) Empattement droit 2473 mm Gauche 2473 mm  
Wheelbase right Left
- 4) Largeur de la carrosserie mesurée aux axes AV 1650 mm  
Width of bodywork measured at front axle
- 5) Largeur de la carrosserie mesurée aux axes AR 1690 mm  
Width of bodywork measured at rear axle
- 6) Longueur hors-tout avec pare-chocs 4420 mm Sans pare-chocs 4250 mm  
Overall length with bumpers Without bumpers
- 7) Type de suspension : AV Independent AR Rigid axle with trailing arms  
Type of suspension : Front Rear

(Photo D)

(Photo E)

Signature et cachet de  
l'autorité sportive nationale,

Signature et cachet  
de la F.I.A.,

Signature and stamp of the national sports authority,

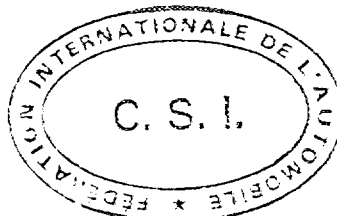

Signature and stamp of the F.I.A.,

NOTA : Les pages 1 à 7 comportent toutes les indications nécessaires à la vérification technique pour les Groupes 2 et 4.  
Page: 08 include necessary information for the scrutineering of cars for Group 2 and 4.

1505

**MOTEUR :**

- 8) Cycle 4 stroke
- 9) Nombre et disposition des cylindres 4 in line  
Number and disposition of cylinders
- 10) Système de refroidissement Water cooling  
Cooling system
- 11) Emplacement et position du moteur Front in line  
Location and position of engine
- 12) Matériau du bloc moteur Cast iron  
Material of engine block
- 13) Roues motrices : AV - AR Front  
Drive wheels : Front - Rear
- 14) Emplacement de la boîte de vitesses Below the engine in a compact unit  
Location of gear-box

**CARROSSERIE ET ÉQUIPEMENT INTÉRIEUR / COACHWORK AND INTERIOR**

- 20) Nombre de portes 2  
Number of doors
- 21) Matériau des portes : AV Steel sheet AR AR  
Material of doors : Front Steel sheet Rear AR
- 22) Matériau du capot moteur Steel sheet  
Material of bonnet
- 23) Matériau du capot coffre Steel sheet  
Material of boot lid
- 24) Matériau de la lunette AR Safety glass  
Material of rear window
- 25) Matériau du pare-brise Laminated glass  
Material of windscreen
- 26) Matériau des glaces des portières AV Safety glass  
Material of front door windows
- 27) Matériau des glaces des portières AR -  
Material of rear door windows
- 28) Système d'ouverture des vitres portières AV Wheel and lever AR AR  
Sliding system of door windows Front mechanism Rear mechanical
- 29) Matériau des glaces de custode Safety glass  
Material of rear quarter lights
- 30) Poids siège (s) AV (enlevés de la voiture avec dossiers, glissières et supports) 15.5 kg  
Weight of front seat(s) (complete with supports and rails. out of the car)
- 31) Matériau du pare-choc AV Plastic, aluminium, rubber Poids 10.0 kg  
Front bumper material Weight
- 32) Matériau du pare-choc AR Plastic, aluminium, rubber Poids 9.0 kg  
Rear bumper material Weight
- 33) Ventilation : oui non / yes no.

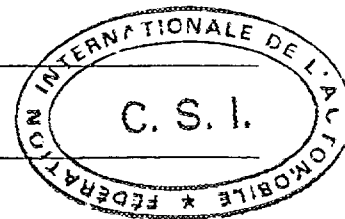

**DIRECTION / STEERING**

- 40) Type Rack and pinion  
 41) Servo-assistance No

**SUSPENSION**

- 45) Suspension AV (photo D) Type de ressort Coil spring  
 Front suspension (photo D) Type of spring  
 46) Nombre d'amortisseurs 2  
 Number of shock absorbers  
 47) Suspension AR (Photo E) Type de ressort Coil spring  
 Rear suspension (Photo E) Type of spring  
 48) Nombre d'amortisseurs 2  
 Number of shock absorbers  
 49) Système de fixation des roues Bolt and nut  
 Method of fixation of wheels

**FREINS - BRAKES**

- 50) Système Hydraulic  
 Method of operation  
 51) Servo frein (si prévu) Type : Vacuum  
 Servo assistance (if fitted) Type :  
 52) Nombre de maîtres-cylindres 1 tandem type  
 Number of master-cylinders

	AVANT / FRONT	ARRIERE / REAR
53) Nombre de cylindres par roue Number of cylinders per wheel	1	2
54) Alésage Bore	54 mm	30 mm
<b>Freins à tambour / Drum brakes</b>		
55) Diamètre intérieur Inside diameter		
56) Nombre de mâchoires par frein Number of shoes per brake		
57) Surface de freinage par frein Total area per brake		
<b>Freins à disques / Disc brakes</b>		
58) Largeur des sabots Width of brake linings	52 mm	39 mm
59) Nombre de sabots par frein Number of pads per brake	2	2
60) Surface de freinage par frein Total area per brake	70450 mm <sup>2</sup>	54 750 mm <sup>2</sup>

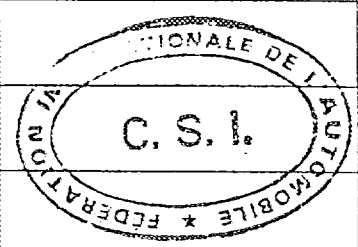

**MOTEUR / ENGINE**

- 65) Alésage 90 mm  
Bore
- 67) Course 78 mm  
Stroke
- 68) Cylindrée totale 1985 (2780)  
Total cylinder-capacity
- 69) Cylindrée maximum autorisée 2012 (2816)  
Maximum cylinder-capacity allowed
- 70) Culasse : matériau Aluminium  
Head : material
- 71) Nombre 1  
Number
- 72) Type de vilebrequin Integral  
Type of crankshaft
- Coulé / estampé Stamped  
~~Moulé / stamped~~
- 73) Nombre de paliers de vilebrequin 5  
Number of crankshaft main bearings
- 74) Diamètre maximal des manetons de vilebrequin 52 mm  
Maximum diameter of the big end journal
- 75) Tête de bielle : type Shell diamètre 52 mm  
Connecting rod big end type
- 76) Matériau des chapeaux des paliers de vilebrequin Cast iron  
Material of bearing cap
- 77) Matériau du volant moteur Steel  
Material of flywheel
- 78) Matériau du vilebrequin Steel  
Crankshaft material
- 79) Matériau de la bielle Steel  
Connecting rod material
- 80) Système de graissage : carter sec - carter humide Oil in sump  
Lubrication system : ~~dry sump~~ - oil in sump
- 81) Nombre de pompes à huile 1  
Number of oil pumps

**Moteur 4 temps / 4 stroke engines**

- 82) Nombre d'arbres à cames 1 Emplacement Overhead  
Number of camshafts Location
- 83) Système de commande Chain  
Type of camshaft drive
- 84) Système de commande des soupapes Cam to tappet  
Type of valve operation
- 85) Nombre de soupapes d'admission par cylindre 1  
Number of inlet valves per cylinder
- 86) Nombre de soupapes d'échappement par cylindre 1  
Number of exhaust valves per cylinder
- 87) Nombre de distributeurs 1  
Number of distributors
- 88) Nombre de bougies par cylindre 1  
Number of spark plug per cylinder



**TRANSMISSION AUX ROUES / DRIVE TRAIN**

**Embrayage / Clutch**

- 90) Nombre de disques 1  
 Number of plates \_\_\_\_\_
- 91) Système de commande Hydraulic  
 Method of operating clutch \_\_\_\_\_

**Boîte de vitesses / Gear-box**

- 92) Contrôle manuel, marque SAAB-SCANIA  
 Manual type, make \_\_\_\_\_
- 93) Nombre de rapports AV 4  
 Number of gear-box ratios forward \_\_\_\_\_
- 94) Boîte automatique, marque \_\_\_\_\_  
 Automatic, make \_\_\_\_\_
- 95) Nombre de rapports AV \_\_\_\_\_  
 Number of gear-ratios forward \_\_\_\_\_

96	Manuelle / Manual		Automatique		Supp. manuel / Automatique			
	Rapport Ratio	N. dents Nr teeth	Rapport Ratio	N. dents Nr teeth	Rapport Ratio	N. dents Nr teeth	Rapport Ratio	N. dents Nr teeth
1	3.44	$\frac{33}{18} \cdot \frac{30}{16}$			2.20	$\frac{27}{23} \cdot \frac{30}{16}$		
2	2.07	$\frac{33}{18} \cdot \frac{26}{23}$			1.53	$\frac{27}{23} \cdot \frac{26}{20}$		
3	1.39	$\frac{33}{18} \cdot \frac{22}{29}$			1.22	$\frac{27}{23} \cdot \frac{25}{24}$		
4	1.00				1.00			
5								
6								
M. AR / Rev.	3.78	$\frac{33}{18} \cdot \frac{33}{16}$			2.42	$\frac{27}{23} \cdot \frac{33}{16}$		

- 97) Surmultiplication type -  
 Overdrive type \_\_\_\_\_
- 98) Nombre de dents -  
 Number of teeth \_\_\_\_\_
- 99) Rapport Ratio \_\_\_\_\_
- 100) Vitesses en marche AV avec surmultiplication \_\_\_\_\_  
 Forward gears on which overdrive can be selected \_\_\_\_\_

**Pont/moteur / Final drive**

- 101) Type du pont moteur Bevel gear  
 Type of final drive 35 - 9
- 102) Type de différentiel Bevel gear  
 Type of differential 3.89
- 103) Nombre de dents 31 - 6  
 Number of teeth 34 - 7
- 104) Rapport Ratio 5.17  
4.86



Photo C

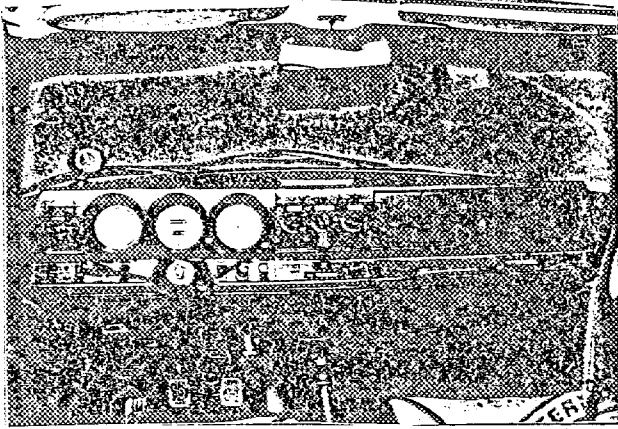

Photo D

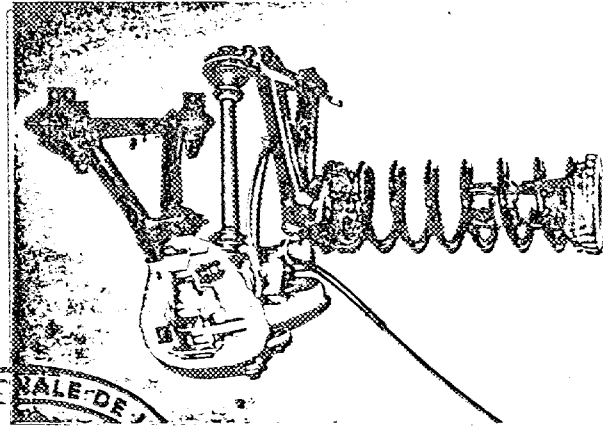

Photo E

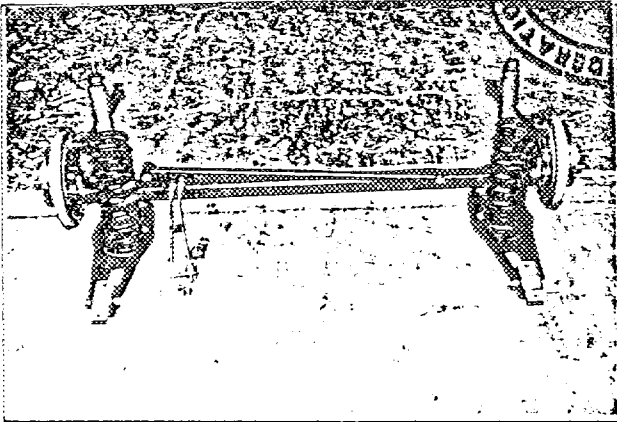

Photo F

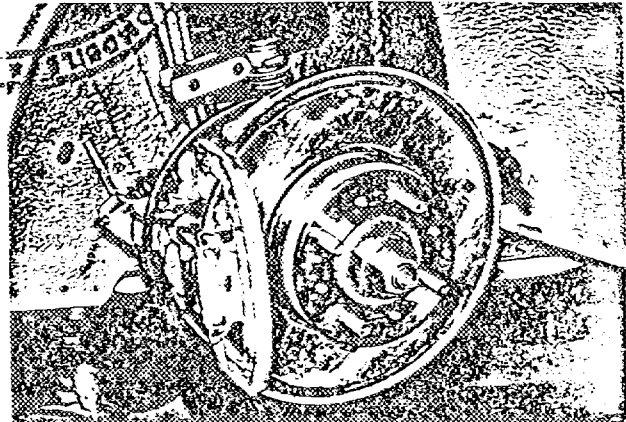

Photo G

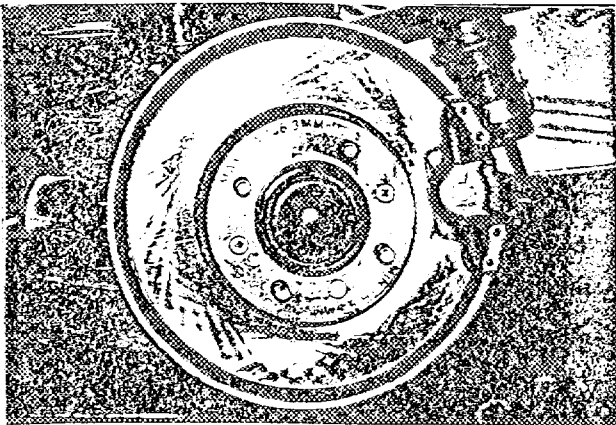

Photo H

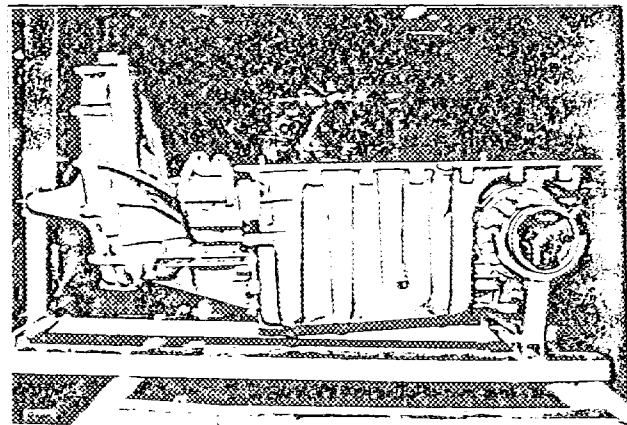

Photo I

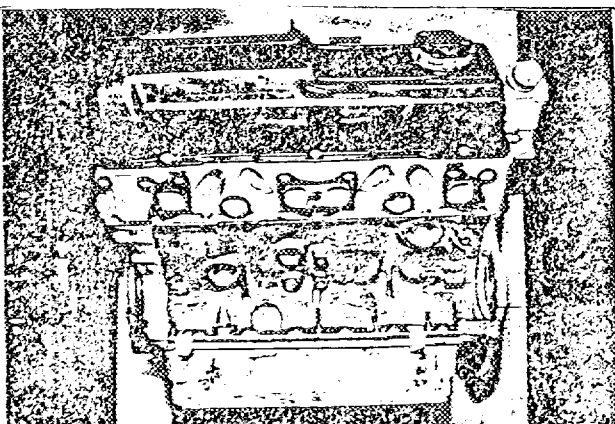

Photo J

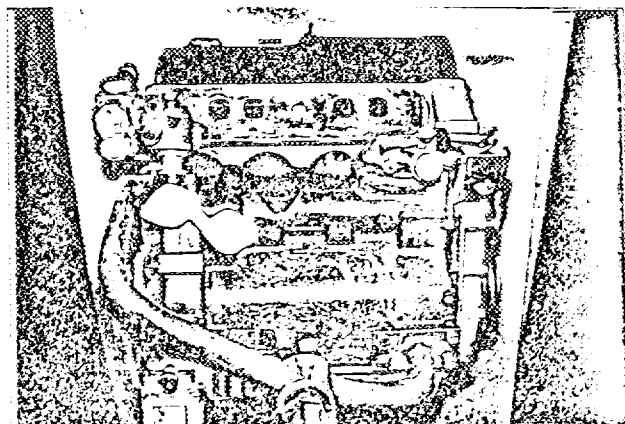
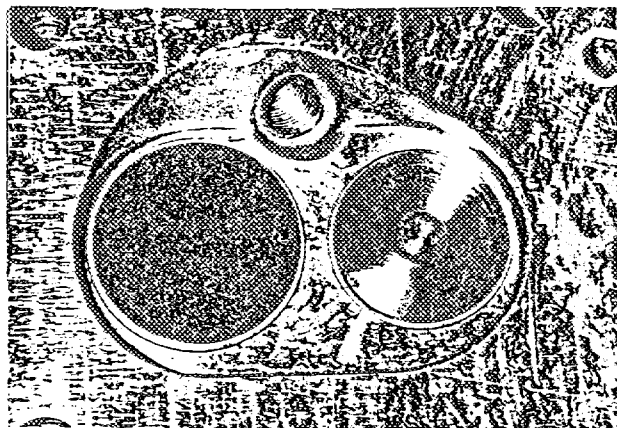

Photo K



Informations supplémentaires  
Additional informations.

- 3) a. Overhang front            927 mm
- b. Overhang rear            1020 mm

BRAKES

- 61) Thickness of discs front    12.8 ± 0.2 mm
- rear                            10.5 ± 0.2 mm



4 5 6

COMPLÉMENT POUR LES GROUPES 1 ET 3  
DU CODE SPORTIF INTERNATIONAL

ADDITIONAL DATA FOR GROUPS 1 AND 3  
TO THE INTERNATIONAL SPORTING CODE

CAPACITÉS ET DIMENSIONS / CAPACITIES AND DIMENSIONS

- 110) Voie AV / Front track 1410 mm
- 111) Voie AR / Rear track 1440 mm
- 112) Garde au sol (pour vérification de la voie)  
Ground clearance (for verification of the track) 175 mm
- 113) Hauteur hors-tout de la voiture / Overall height of the car 1440 mm
- 114) Capacité du réservoir d'essence (y compris la réserve)  
Fuel tank capacity (including reserve) 55 litres
- 115) Nombre de places 5      116) Poids 1080 kg  
Seating capacity      Weight

EQUIPEMENT ET GARNITURES / ACCESSORIES AND UPHOLSTERY

- 120) Chauffage intérieur : oui - non  
Interior heating : yes - ~~no~~
- 121) Climatisation (sur option) : oui - non  
Air conditioning (in option) : ~~yes~~ - no
- 122) Sièges AV : type Single seats  
Front seats : type
- 123) Sièges AR : type Seat bench  
Rear seats : type

ROUES / WHEELS

- 124) Matériau Aluminium  
Matériel
- 125) Poids unitaire (roue nue) 7.0 kg (tolérance ± 5%)  
Unitary weight (bare wheel)
- 126) Diamètre de la jante 381 mm  
Rim diameter
- 127) Largeur de la jante 139.7 mm  
Rim width

SUSPENSION

- 130) Stabilisateur AV (si prévu) -  
Front stabilizer (if fitted)
- 131) Stabilisateur AR (si prévu) -  
Rear stabilizer (if fitted)

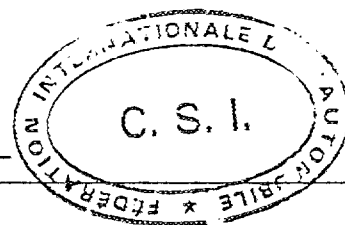



**MOTEUR / ENGINE**

- 135) Cylindrée par cylindre / Capacity per cylinder 496 cm<sup>3</sup>
- 136) Chemises : oui / non  
Sleeves : yes / no.
- 137) Nombre d'orifices d'admission par cylindres 1  
Number of inlet ports per cylinder
- 138) Nombre d'orifices d'échappement par cylindre 1  
Number of exhaust ports per cylinder
- 139) Rapport volumétrique 7.2:1  
Compression ratio
- 140a) Volume de la chambre de combustion (minimum) 75 cm<sup>3</sup>  
Volume of the combustion chamber
- 140b) Volume de la chambre de combustion dans la culasse 48.5 ± 2 cm<sup>3</sup>  
Volume of combustion chamber in head
- 141) Épaisseur du joint de culasse 1.2 ± 0.1 mm  
Thickness of head gasket inter tightened
- 142) Piston, matériau Aluminium  
Piston, material
- 143) Nombre de segments 3  
Number of rings
- 144) Distance de la médiane de l'axe du piston au sommet du piston 40 ± 0.5 mm  
Distance from gudgeon pin center line to highest point of piston crown
- 145) Capacité du réservoir - carter 4.0 litres  
Capacity, lubricant
- 146) Radiateur d'huile : oui - non Yes  
Oil cooler : yes - ~~no~~
- 147) Capacité du circuit de refroidissement 8.0 litres  
Capacity of cooling system
- 148) Ventilateur (si prévu), diamètre 282 mm Matériau Plastic  
Cooling fan (if fitted), diameter Material
- 149) Nombre de pales du ventilateur 11  
Number of fan blades
- 150) Paliers vilebrequin, type Shell diamètre 58 mm  
Crankshaft main bearings, type diameter
- 151) Poids volant (nu) -  
Weight of flywheel (clean)
- 152) Poids du volant avec couronne de démarreur 9.1 kg  
Weight of flywheel with starter ring
- 153) Poids du volant avec embrayage 14.9 kg  
Weight of flywheel with clutch
- 154) Poids du vilebrequin 16.0 kg  
Weight of crankshaft
- 155) Poids de la bielle 0.81 kg  
Weight of con-rod
- 156) Poids du piston avec axe et segments 0.690 kg  
Weight of piston with rings and pin

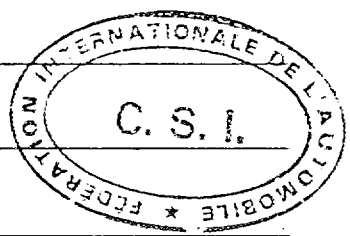
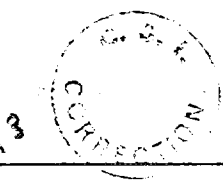

**ADMISSION / INLET**

160) Matériau du collecteur d'admission Material of inlet manifold	<u>Aluminium</u>
161) Diamètre extérieur des soupapes Outside diameter of valves	<u>42 ± 0.2 mm</u>
162) Levée maximum des soupapes Maximum valve lift	<u>9.83 mm</u>
163) Nombre de ressorts par soupape Number of springs per valve	<u>1</u>
164) Type de ressort Type of spring	<u>Coil</u>
165) Jeu théorique pour le calage de la distribution Theoretical timing clearance	<u>0.20 mm</u>
166) Avance d'ouverture (avec jeu théorique) Valves open at (With tolerance for tappet clearance indicated)	<u>40° ± 1° BTDC</u>
167) Retard de fermeture Valves close at	<u>68° ± 1° ABDC</u>

**ÉCHAPPEMENT / EXHAUST**

170) Matériau du collecteur d'échappement Material of exhaust manifold	<u>Cast iron</u>
171) Diamètre extérieur des soupapes Outside diameter of valves	<u>34.5 ± 0.2 mm</u>
172) Levée maximum des soupapes Maximum valve lift	<u>11.23 mm</u>
173) Nombre de ressorts par soupape Number of springs per valve	<u>1</u>
174) Type de ressort Type of spring	<u>Coil</u>
175) Jeu théorique pour le calage de la distribution Theoretical timing clearance	<u>0.40 mm</u>
176) Avance d'ouverture (avec jeu théorique) Valves open at (with tolerance for tappet clearance indicated)	<u>90° ± 1° BBDC</u>
177) Retard de fermeture Valves close at	<u>30° ± 1° ATDC</u>

**ALIMENTATION PAR CARBURATEURS / CARBURATION**

180) Nombre de carburateurs Number of carburetors	<u>-</u>
181) Type	<u>-</u>
182) Marque Make	<u>-</u>
183) Modèle Model	<u>-</u>
184) Nombre de passages de gaz par carburateur Number of mixture passages per carburettor	<u>-</u>

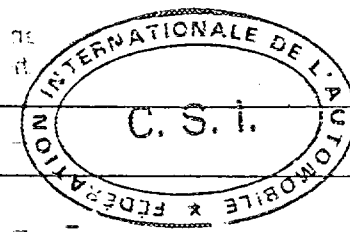

- 185) Diamètre de la tubulure de gaz à la sortie du carburateur  
Flange hole diameter of exit port of carburettor -
- 186) Diamètre du diffuseur au point d'étranglement maximum  
Minimum diameter of venturi -
- Injection (si prévue) (if fitted)
- 187) Marque de la pompe Bosch  
Make of pump
- 188) Nombre de pistons -  
Number of plungers
- 189) Modèle ou type de la pompe Roll cell type  
Model or type of pump
- 190) Nombre total d'injecteurs 4  
Total number of injectors
- 191) Emplacement des injecteurs Inlet manifold  
Location of injectors
- 192) Diamètre de la pipe d'admission au point de passage le plus étroit 55 mm  
Minimum diameter of inlet pipe

**ÉQUIPEMENT DU MOTEUR / ENGINE ACCESSORIES**

- 195) Pompe à essence - mécanique et/ou électrique Electrical  
Fuel pump - mechanical and/or electrical
- 196) Nombre 1  
Number
- 197) Type du système d'allumage Transistorized with distributor and coil  
Type of ignition system
- 198) Nombre de bobines 1  
Number of ignition coils
- 199) Génératrice : type Alternator Nombre 1  
Generator : type Number
- 200) Système d'entraînement Belt  
Method of drive
- 201) Batterie / Battery  
 a) Tension 12 (14)      b) Emplacement Engine compartment  
 Voltage Location



205) Arbres à cames / Camshaft  
 R : Centre

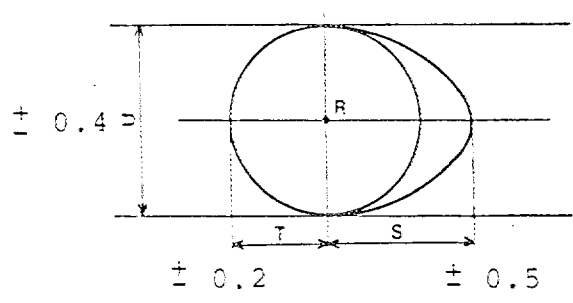

	Cam admission Inlet cam	Cam échappement Exhaust cam
S =	<u>28.63</u> mm _____ inches	S = <u>29.83</u> mm _____ inches
T =	<u>19.50</u> mm _____ inches	T = <u>19.30</u> mm _____ inches
U =	<u>39.06</u> mm _____ inches	U = <u>39.10</u> mm _____ inches

**TRANSMISSION AUX ROUES / WHEEL DRIVE**

**Embrayage / clutch**

- 210) Type Diaphragm spring
- 211) Diamètre / Diameter 219 mm
- 212) Diamètre des garnitures : intérieur 146 mm extérieur 217 mm  
 Diameter of linings : interior outside
- 213) Nombre de disques 1  
 Number of discs

**Boîte de vitesses / Gear-box**

- 215) Nombre de rapports AV synchronisés 4  
 Number of forward synchronised ratios
- 216) Emplacement de la commande Floor  
 Location of the gear lever
- 217) Boîte automatique - emplacement de la commande -  
 Automatic gear-box - location of gear lever
- 218) Surmultiplication - type -  
 Overdrive type
- 219) Rapport de surmultiplication -  
 Overdrive ratio

**Pont moteur - Final drive**

- 220) Type du pont autobloquant (si prévu) -  
 Type of limited slip differential (if provided)
- 221) Nombre de dents du couple conique 35 - 9 ou 31 - 6  
 Number of teeth of final drive or
- 222) Rapport au couple conique 3.89 ou 5.17  
 Final drive ratio or

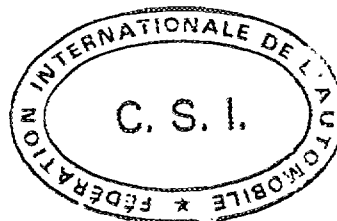

Photo K

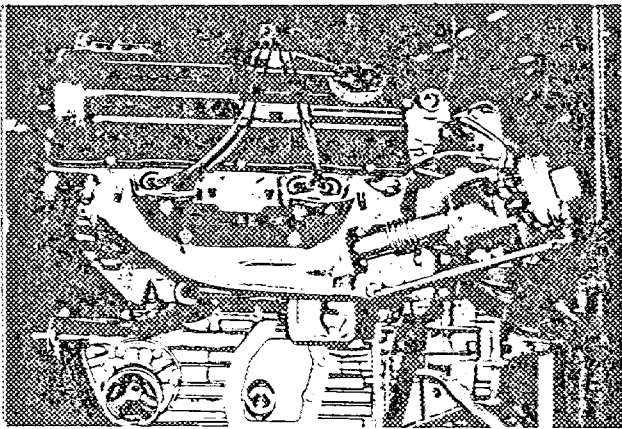

Photo L

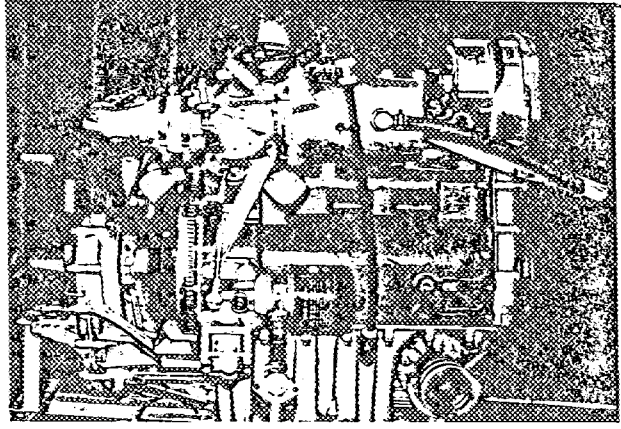

Photo M

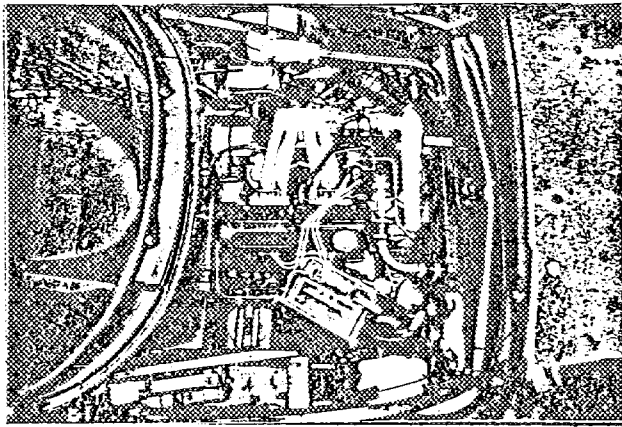

Photo N

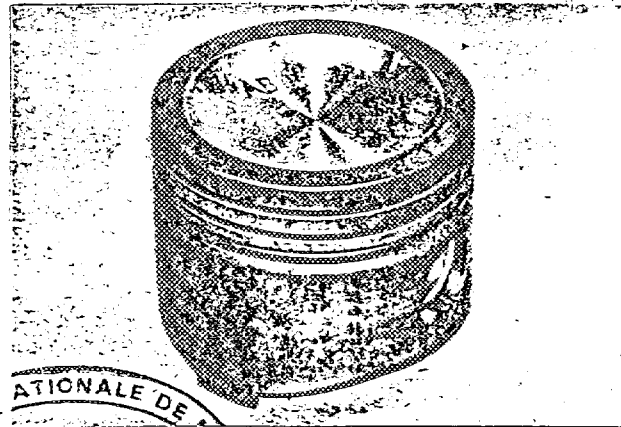

Photo P

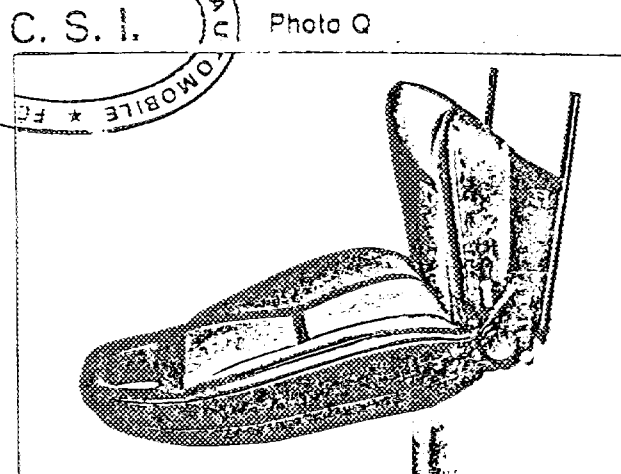
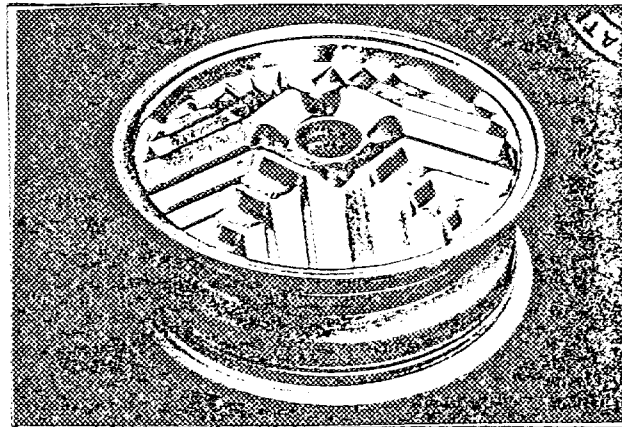

Photo R

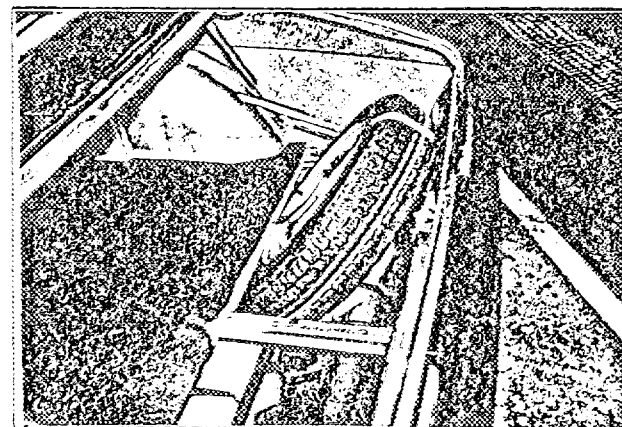
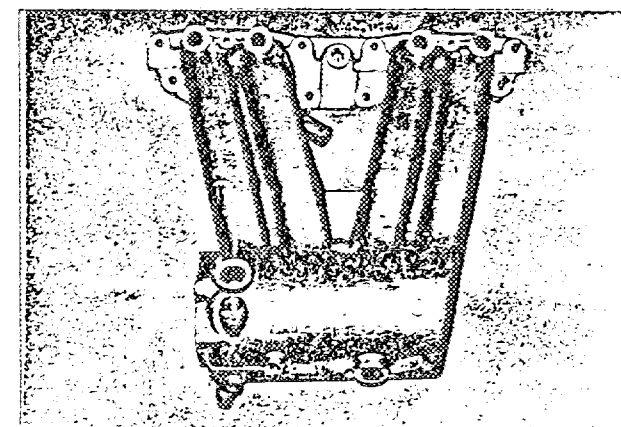

Photo S



1025

Dessin orifices collecteur admission, face côté culasse.

Drawing inlet manifold ports, side of cylinderhead.

avec dimensions with

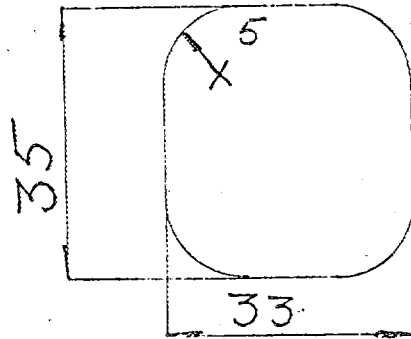

Tolerances as for unfinished castings. (Ports chamfered 1 mm 30°)

Dessin orifices admission culasse face collecteur.

Drawing of entrance to inlet port of cylinderhead.

avec dimensions with

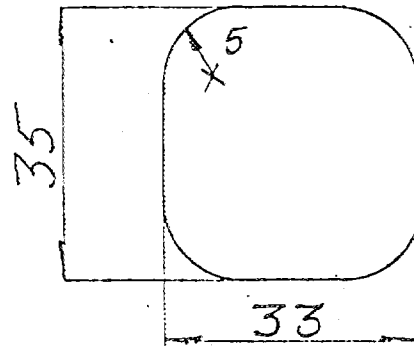

Dessin orifices collecteur échappement face côté culasse.

Drawing of exhaust manifold ports, side of cylinderhead.

avec dimensions with

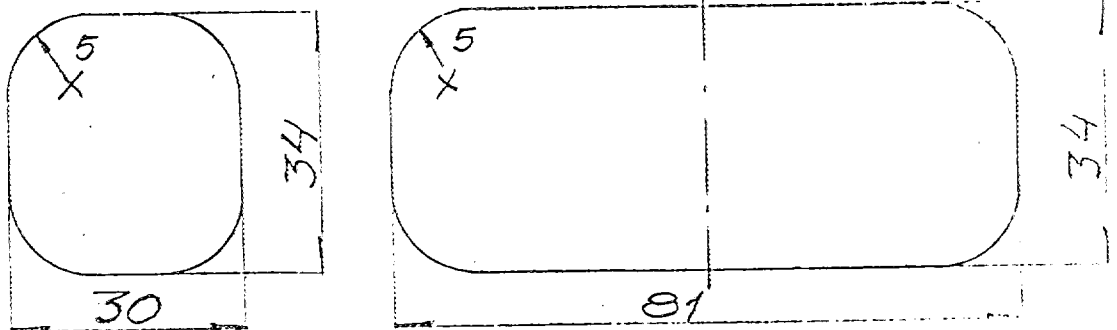

Dessin orifices échappement culasse face collecteur.

Drawing of exit to exhaust port cylinderhead.

avec dimensions with

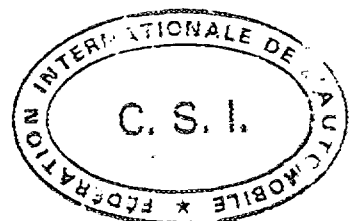
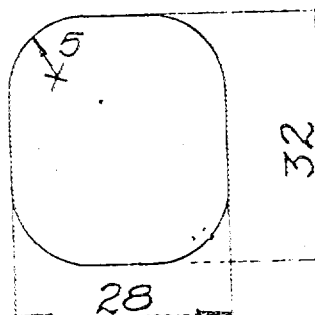

Photo T

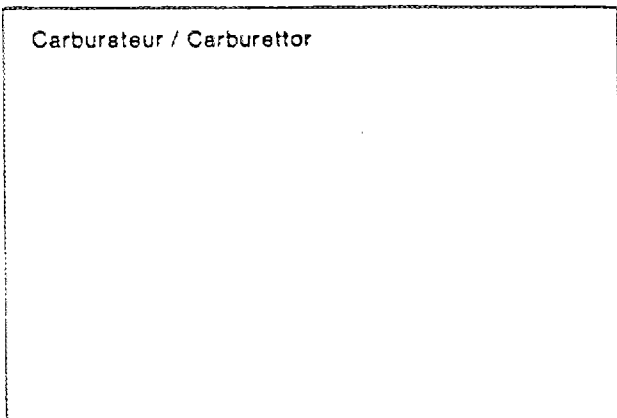

Photo U

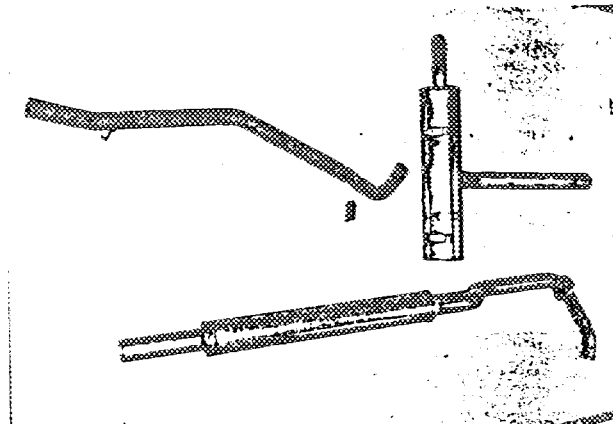
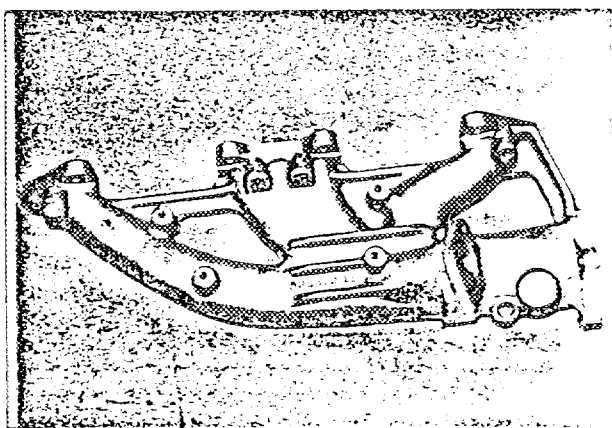
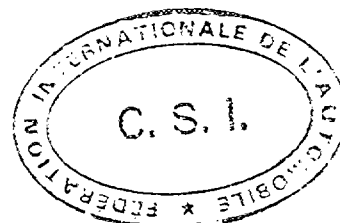

Photo V



Informations supplémentaires  
Additional information



Inlet and exhaust manifolds, ports and ducts machined in series production.

Exit port of exhaust manifold 45 x 57 mm (radius of corners 10 mm)

Photo W

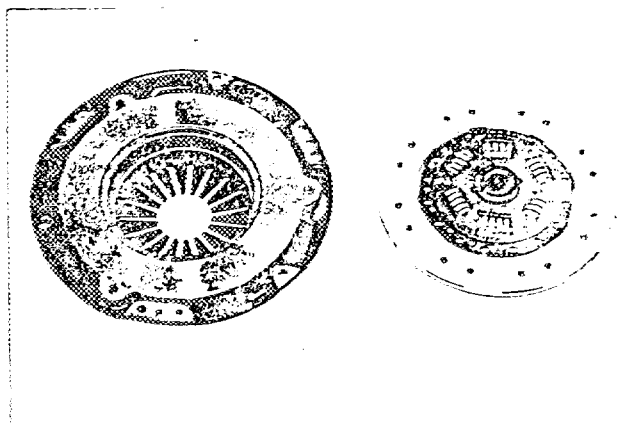

Grille de vitesses  
Gear change gate

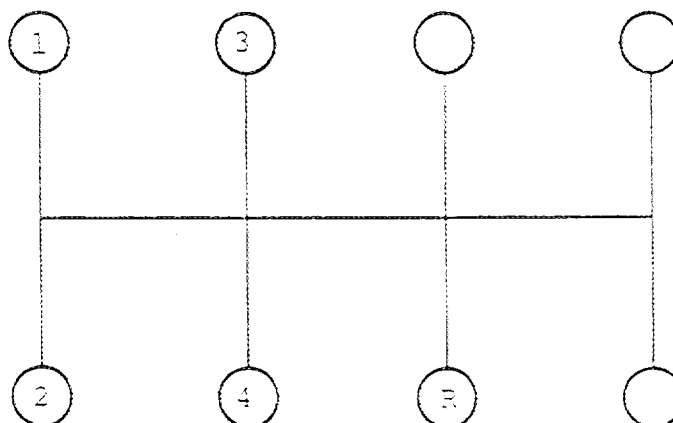

A - Characteristics of turbocharger concerning Group 1

1. TURBOCHARGER (photos 1-4)
  - 1.1 Make and type: Garrett AiResearch
  
2. TURBINE HOUSING (photo 5)
  - 2.1 Number of exhaust gas entries: One
  - 2.2 Without vanes
  - 2.3 Dimensions of exhaust gas entry: See sketch I
  - 2.4 Dimensions of exhaust gas exit: See sketch II
  
3. IMPELLER HOUSING
  - 3.1 Dimensions of air intake: See sketch III
  - 3.2 Dimensions of air exit: See sketch IV
  
4. TURBINE WHEEL (sketch V)
  - 4.1 Maximum outer diameter: 58.9 ±0.5 mm
  - 4.2 Outer diameter at exit of exhaust gas: 45.7 ±0.2 mm
  - 4.3 Height of blade at OD (ref. 4.1/4.2): 4.4/14.6 ±0.5 mm
  - 4.4 Thickness of blade at OD (ref. 4.1/4.2): 1.2/ 0.6 ±0.4 mm
  - 4.5 Number of blades: 11
  
5. IMPELLER WHEEL (sketch VI)
  - 5.1 Material: Light alloy
  - 5.2 Maximum outer diameter: 60.2 ±0.5 mm
  - 5.3 Outer diameter at air intake: 37.7 ±0.2
  - 5.4 Height of blade at OD (ref. 5.2/5.3): 0/11.0 ±0.5 mm
  - 5.5 Thickness of blade at OD (ref. 5.2/5.3): 1.0/0.7 ±0.3 mm
  - 5.6 Number of blades: 6+6
  
6. ADJUSTMENT OF THE PRESSURE (By pass valve - photos 6-7)
  - 6.1 Maximum turbocharging pressure:  $0.92 \pm 0.10 \text{ kp/cm}^2$  at 3000 rpm  
measured at pressure switch  
connection to inlet manifold
  - 6.2 a) Type of valve: Disc valve
  
7. EXHAUST SYSTEM (photos U and V)
  - 7.1 Diameter of exhaust pipe at turbocharger connector: 57 mm
  - 7.2 Diameter of exhaust pipe at entry into atmosphere: 51 mm

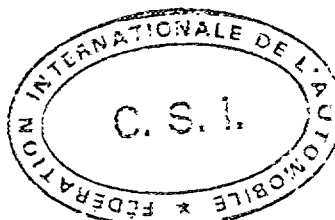



1.

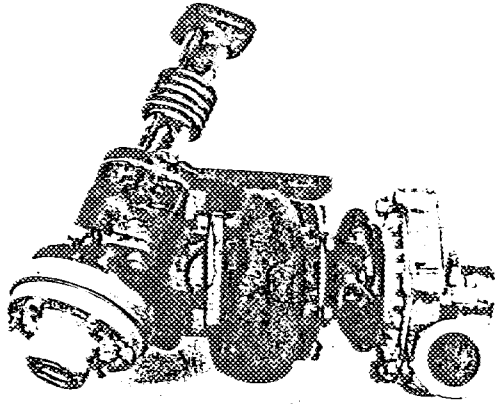

2.

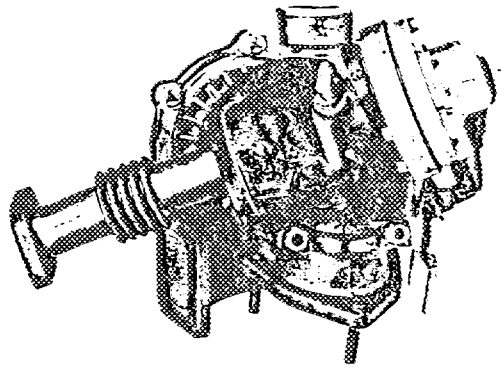

3.

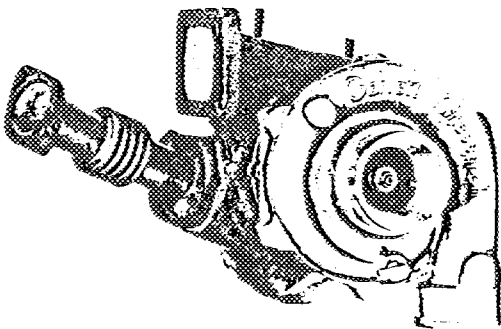

4.

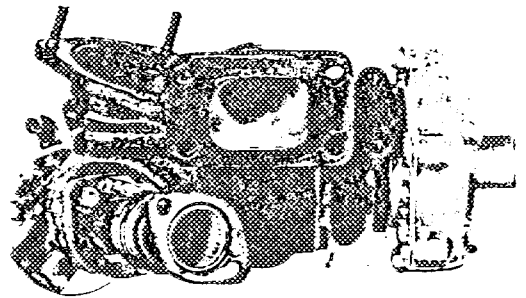

5.

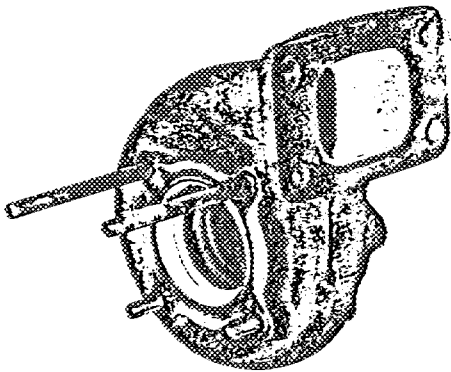

6.

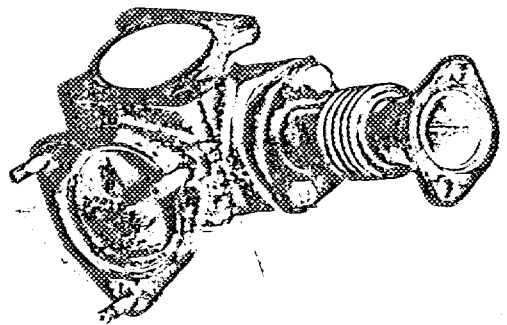

7.

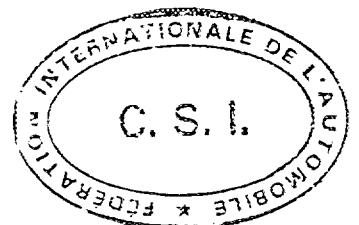
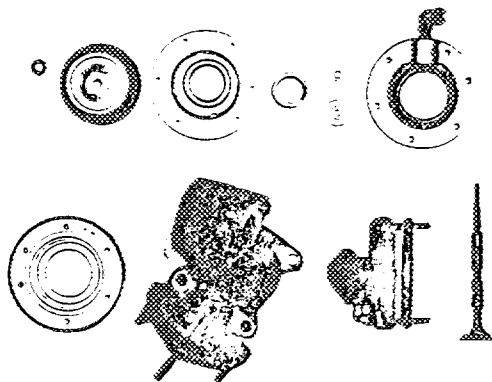

I

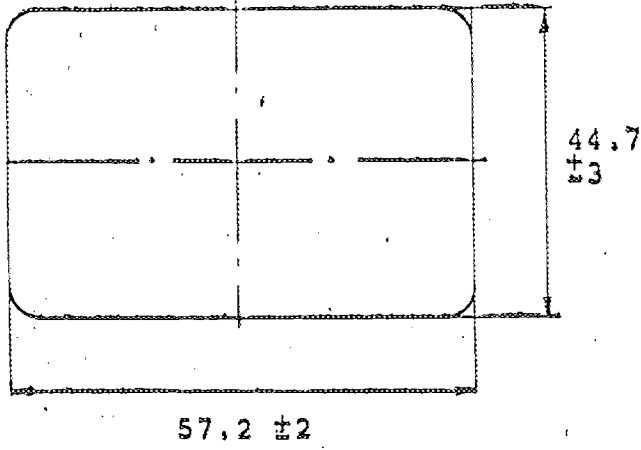

II

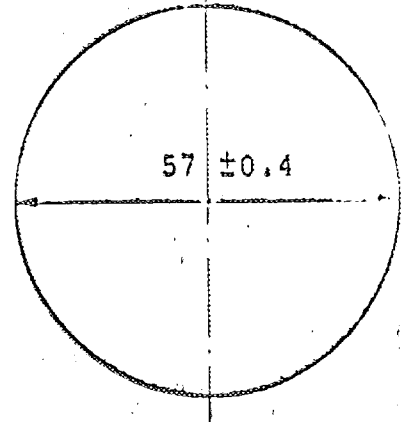

III

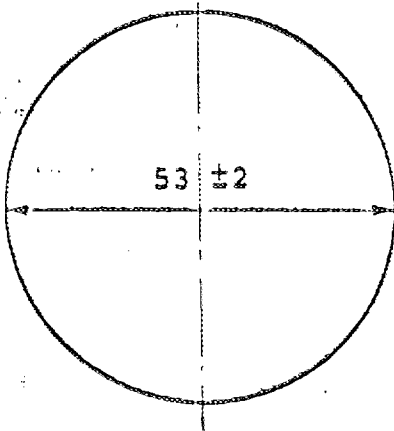

IV

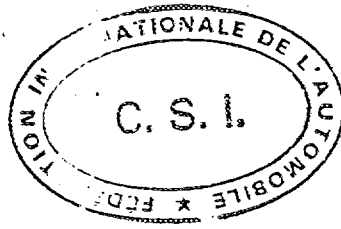
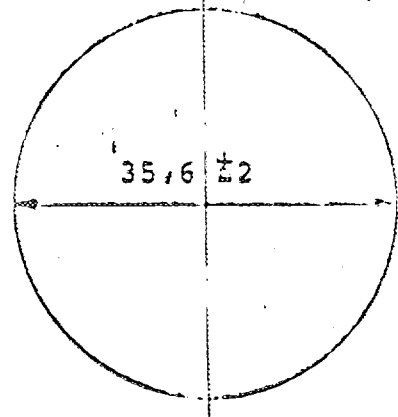

V

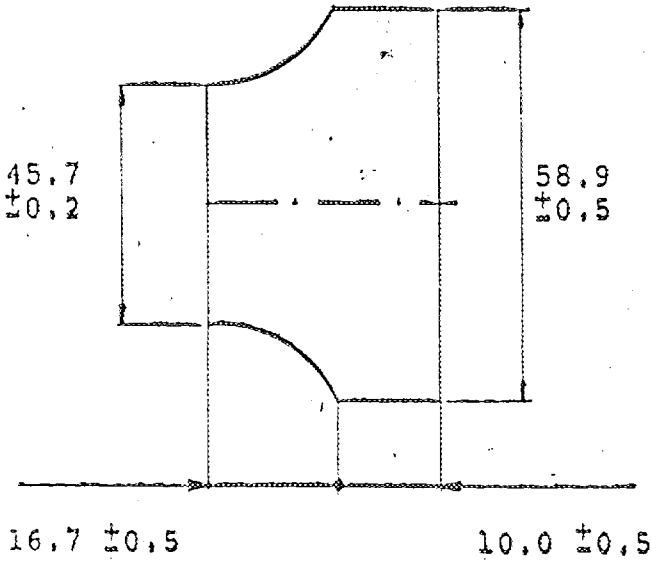

VI

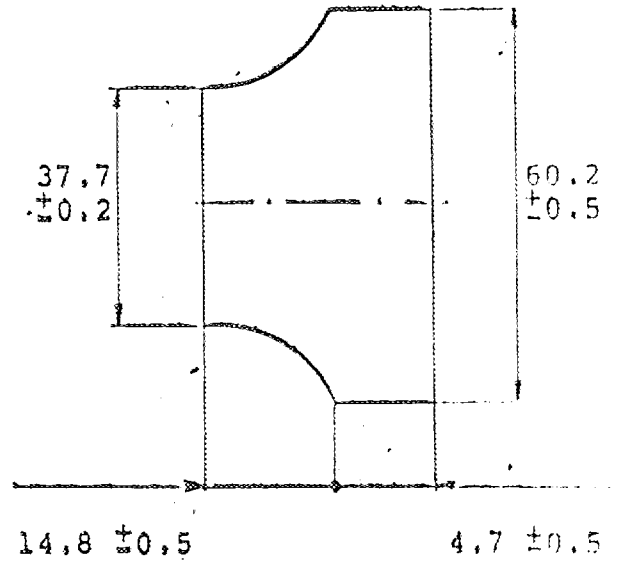

Turbocharger pressure regulator assy. (83 69 10)

Valve diameter 31 ± 0.3 mm

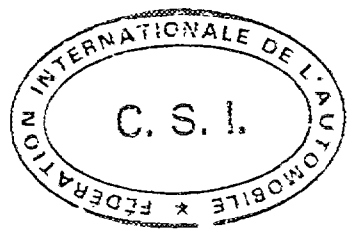
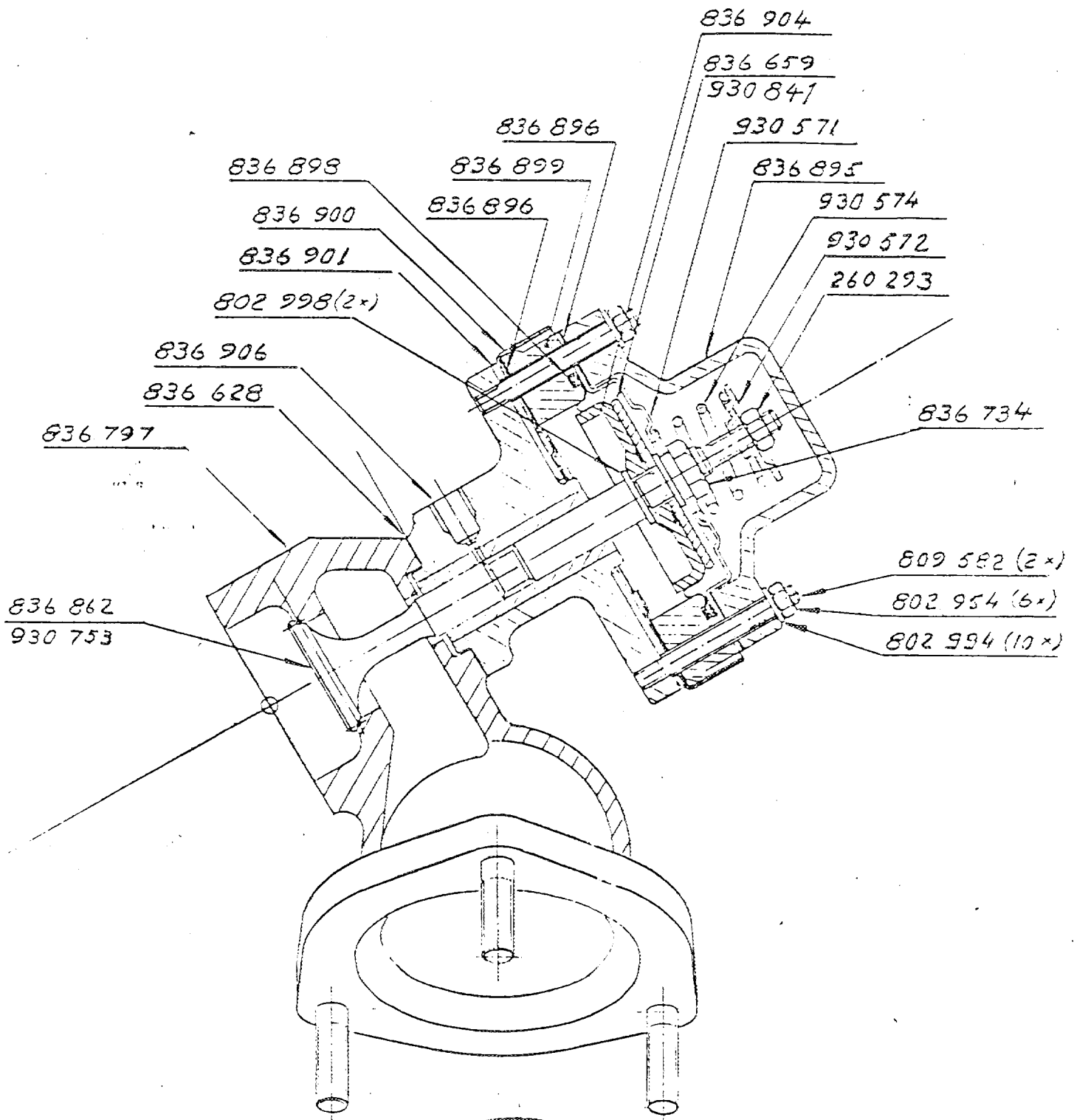

Turbocharger valve housing assy. (836797)

(tolerances as for unfinished castings)

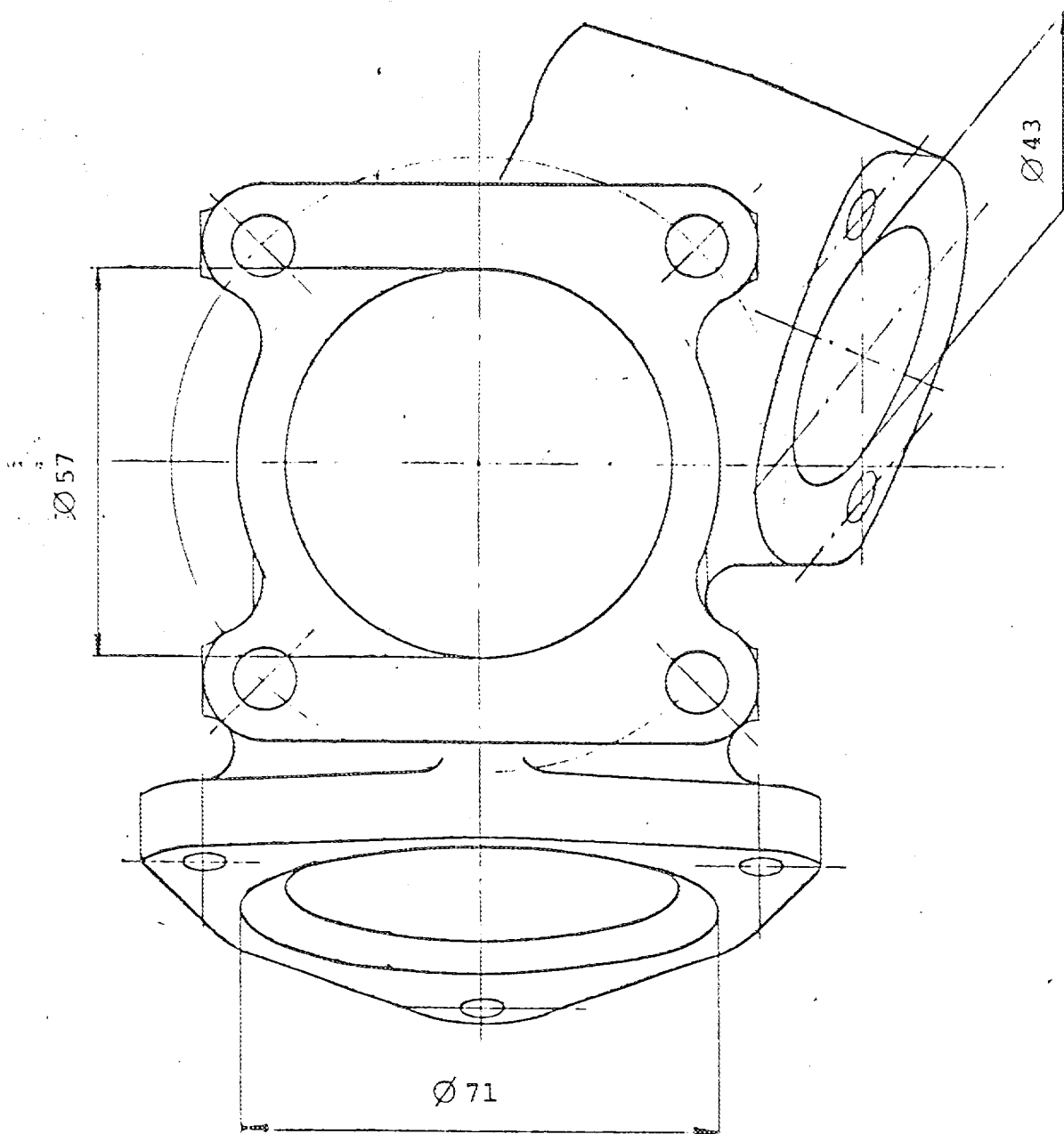

## FEDERATION INTERNATIONALE DE L'AUTOMOBILE

Form of recognition (extension) in accordance with  
Appendix J to the International Sporting Code.

Manufacturer	SAAB-SCANIA AB	Model	SAAB 99 SEDAN TURBO
		Chassis	
Serial No. inaugurating this extension		Engine	
Manufacturing date of the first vehicle constructed with the modifications			
Commercial denomination of modified model			SAAB 99 SEDAN TURBO
This extension of recognition is considered:		<del>variation - normal</del>	
		<del>development of original</del>	
		<del>vehicle type</del>	
Recognition is valid from	-1.AVR.1979	List	

## Description of modifications:

Strengthened upper wishbone	No 15230 and No 15248
Strengthened lower wishbone	No 15255 and No 15263
Strengthened rear axle	No 18002 (photo E unchanged)
Roll bar attachment	(see photo)
41) Power steering	No 860930
80) Dry sump lubrication kit	No 18010 (see photos)

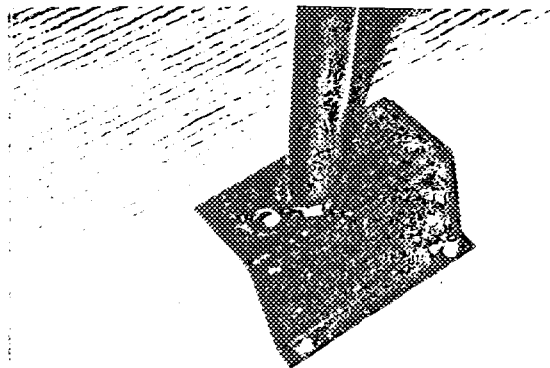
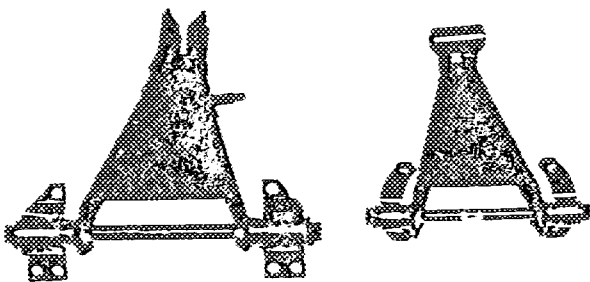

Signature and stamp of the  
National Sporting Authority:

Signature and stamp of the F.I.A.:



FEDERATION INTERNATIONALE DE L'AUTOMOBILE

Form of recognition (extension) in accordance with Appendix J to the International Sporting Code.

Manufacturer	SAAB-SCANIA AB	Model	SAAB 99 SEDAN TURBO
Serial No. inaugurating this extension		Chassis	
Manufacturing date of the first vehicle constructed with the modifications		Engine	
Commercial denomination of modified model			SAAB 99 SEDAN TURBO
This extension of recognition is considered:		variation - <del>normal</del>	
		development of original	
		vehicle type	
Recognition is valid from		List	

Description of modifications:

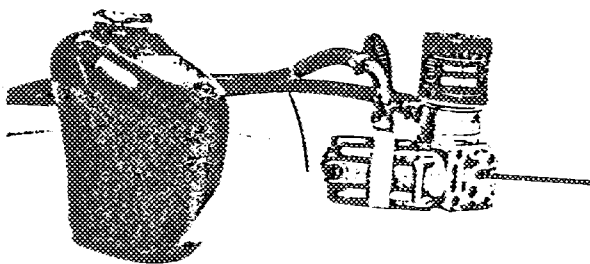
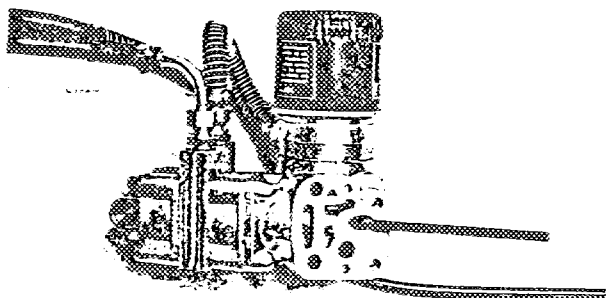

Signature and stamp of the National Sporting Authority:

A handwritten signature in black ink, appearing to be a stylized name or initials.

Signature and stamp of the F.I.A.:

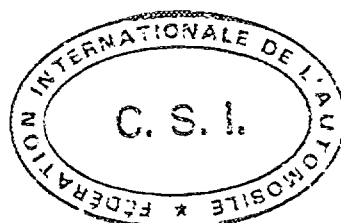

FEDERATION INTERNATIONALE DE L'AUTOMOBILE

Form of recognition (extension) in accordance with Appendix J to the International Sporting Code.

Manufacturer	SAAB-SCANIA AB	Model	SAAB 99 SEDAN TURBO
		Chassis	
Serial No. inaugurating this extension		Engine	
Manufacturing date of the first vehicle constructed with the modifications			
Commercial denomination of modified model			SAAB 99 SEDAN TURBO
This extension of recognition is considered:		variation - <del>rommek</del>	
		<del>development of original</del>	
		<del>vehicle type</del>	
Recognition is valid from		List	

Description of modifications:

CERTIFICATE

We hereby certify that the structure of the cars (SAAB 900 Turbo and 99 Sedan Turbo), including roll bar (roll cage) in full conformity with the FIA regulation but where the main hoop is connected to the body by the roll bar attachment shown on picture in form 1/IV, complies with the standards required by the FIA for open cars.

Trollhättan, January 9, 1979

SAAB-SCANIA AB  
Development and Production Sector  
Engineering Department

*Henrik Gustavsson*  
Henrik Gustavsson  
Technical Director

Signature and stamp of the National Sporting Authority:  
SVENSKA BILSPORTFÖRBUNDET  
THE SWEDISH AUTOMOBILE SPORT FEDERATION

Signature and stamp of the F.I.A.:  
C. S. I.  
FEDERATION INTERNATIONALE DE L'AUTOMOBILE

**FEDERATION INTERNATIONALE DE L'AUTOMOBILE**

Form of recognition (extension) in accordance with Appendix J to the International Sporting Code.

Manufacturer	SAAB-SCANIA AB	Model	SAAB 99 SEDAN TURBO
Serial No. inaugurating this extension		Chassis	
Manufacturing date of the first vehicle constructed with the modifications		Engine	
Commercial denomination of modified model			SAAB 99 SEDAN TURBO
This extension of recognition is considered:		variation - normal development of original vehicle type	
Recognition is valid from	-1 AVR.1979	List	

Description of modifications:

	Front	Rear
Brakes Teves type	2 L4 34	LC <sub>1</sub> 33W
93) Number of cylinders per wheel	4	2
94) Bore of wheel cylinders	34 mm	33 mm
100) Outside diameter (ventilated disc)	270 mm	-
101) Thickness of disc	22 mm	-
102) Length of brake linings	77 mm	56 mm
103) Width of brake linings	43 mm	38 mm
104) Number of pads per shoe	2	2
105) Total area per brake	59800 mm <sup>2</sup>	54700 mm <sup>2</sup>
Pressure limiting valve Teves type BR 18		

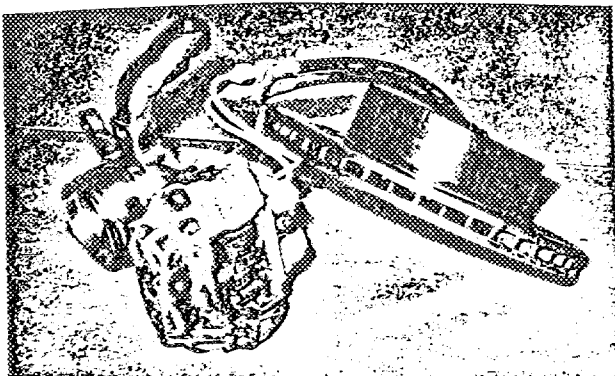

Signature and stamp of the National Sporting Authority:

*[Handwritten signature]*

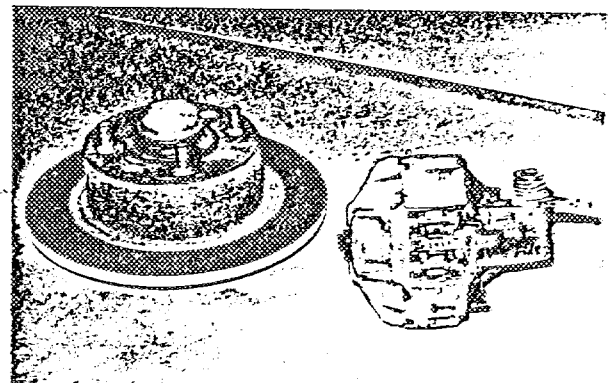

Signature and stamp of the F.I.A.:



*[Handwritten signature]*



1595

FEDERATION INTERNATIONALE DE L'AUTOMOBILE

Form of recognition (extension) in accordance with Appendix J to the International Sporting Code.

Manufacturer	SAAB-SCANIA AB	Model	SAAB 99 SEDAN TURBO
		Chassis	
Serial No. inaugurating this extension		Engine	
Manufacturing date of the first vehicle constructed with the modifications			
Commercial denomination of modified model			SAAB 99 SEDAN TURBO
This extension of recognition is considered:		variation - <del>modification</del>	
		<del>development</del>	
		<del>vehicle type</del>	
Recognition is valid from	-1.FEV.1979	List	

Description of modifications:

ROLL CAGE SAAB NO 18028

Material: British Standard 1474 HE 30 (AlSiMgMn)  
 Tensile strength: 31 kp/mm<sup>2</sup>  
 Diameter: 38 mm  
 Wall thickness: 3.25 mm  
 Weight: 12 kg

« le constructeur certifie que la structure de la voiture, arceau compris, est conforme aux normes exigées par la FIA pour les voitures ouvertes »

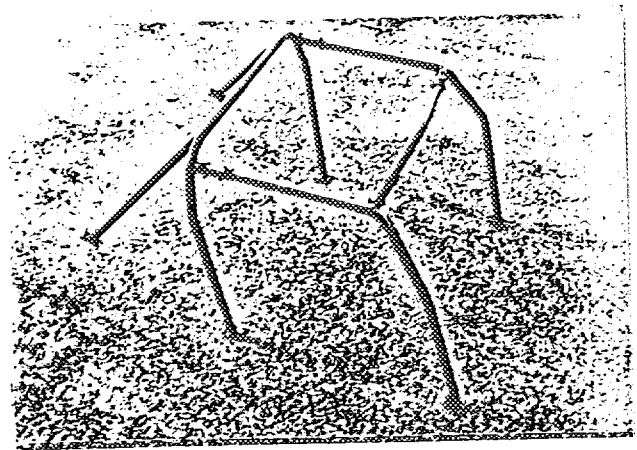

Signature and stamp of the National Sporting Authority:

SVENSKA BILSPORTFÖRBUNDET  
 THE SWEDISH AUTOMOBILE SPORT FEDERATION

*[Handwritten signature]*

Signature and stamp of the F.I.A.:



*[Handwritten signature]*

**FEDERATION INTERNATIONALE DE L'AUTOMOBILE**

Form of recognition (extension) in accordance with Appendix J to the International Sporting Code.

Manufacturer	SAAB-SCANIA	Model	SAAB 99 SEDAN TURBO
		Chassis	
Serial No. inaugurating this extension		Engine	
Manufacturing date of the first vehicle constructed with the modifications			
Commercial denomination of modified model			SAAB 99 SEDAN TURBO
This extension of recognition is considered:		variation - <del>normal</del>	
		<del>development of original</del>	
		<del>vehicle type</del>	
Recognition is valid from	-1.001.1979	List	

Description of modifications:

DISC BRAKE FRONT SAAB NO 18085  
 DISC BRAKE REAR SAAB NO 18093

	Front	Rear
53. Number of cylinders per wheel	4	2
54. Bore	38 mm	51 mm
58. Width of brake linings	51 mm	52 mm
59. Number of pads per brake	2	2
60. Total area per brake	72900 mm <sup>2</sup>	74300 mm <sup>2</sup>
61. Thickness of disc	25.4 mm	11.2 mm



BRAKE BALANCE VALVE SAAB NO 18101

Signature and stamp of the National Sporting Authority:

**SVENSKA BILSPORTFÖRBUNDET**  
 THE SWEDISH AUTOMOBILE SPORT FEDERATION

Signature and stamp of the F.I.A.:

