

IMPORTANT - the underlined items must be stated in two measuring systems, one of which must be the metric system. See conversion table hereafter.

CAPACITIES AND DIMENSIONS

1. <u>Wheelbase</u>	2,250	mm	88.58	inches
2. <u>Front track</u>	1,245	mm	49.02	inches *
3. <u>Rear track</u>	1,220	mm	48.03	inches *
4. Overall length of the car		388.5	cm	inches
5. Overall width of the car		146.5	cm	inches
6. Overall height of the car		134.5	cm	inches
7. <u>Capacity of fuel tank</u> (reserve included)			45	ltrs
	11.89	Gallon US	9.90	Gallon Imp.
8. Seating capacity	5			
9. <u>Weight</u> , total weight of the car with normal equipment, water, oil and spare wheel but without fuel nor repair tools:				
	840	kg	1,852	lbs
				16.53
				cwt

* Differences in track caused by the use of other wheels with different rim widths must be stated when recognition is requested for the wheels concerned.

Specify ground clearance in relation to the track and give drawing of two fixed points of the vehicle's structure at which measurements are taken.

These ground clearance dimensions are only for information when checking the track and can in no way affect the eligibility of the car.

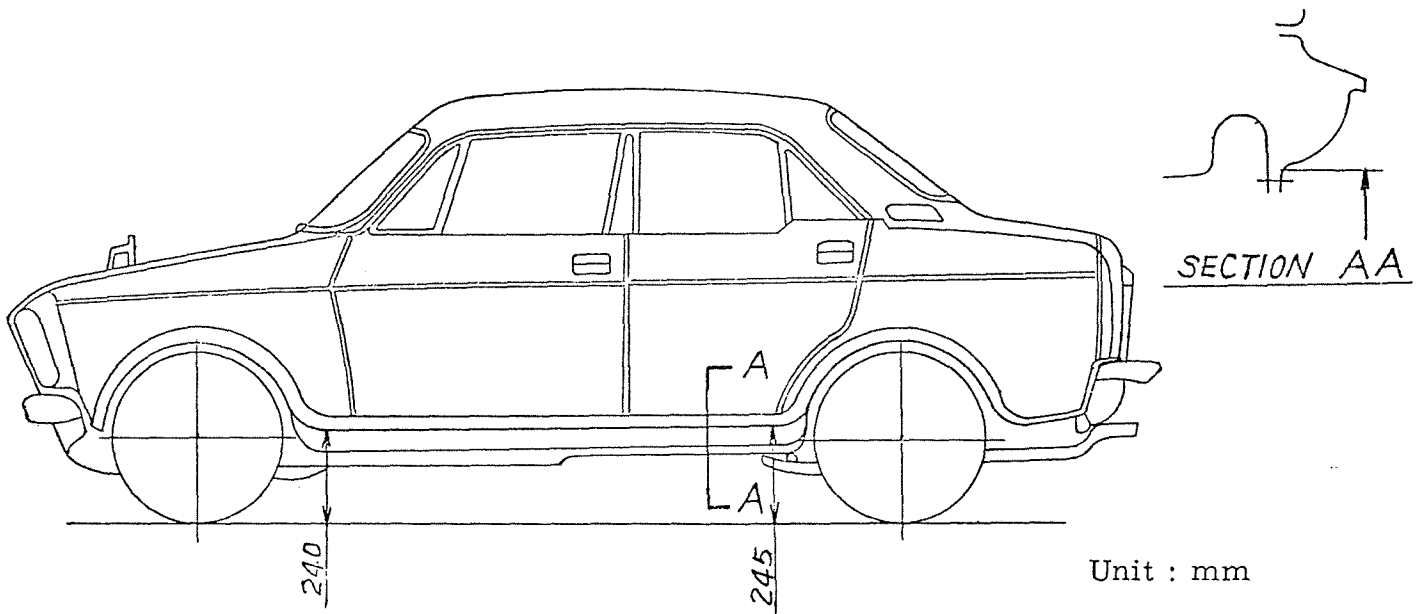

CONVERSION TABLE

1 inch / pouce	--	2.54 cm	1 quart US	--	0.9464 ltrs
1 foot / pied	--	30.4794 cm	1 pint (pt)	--	0.568 ltrs
1 square inch / pouce carré	--	6.452 cm ²	1 gallon Imp.	--	4.546 ltrs
1 cubic inch / pouce cube	--	16.387 cm ³	1 gallon US	--	3.785 ltrs
1 pound / livre (lb)	--	453.593 gr.	1 hundred weight (cwt)	--	50.802 kg

3

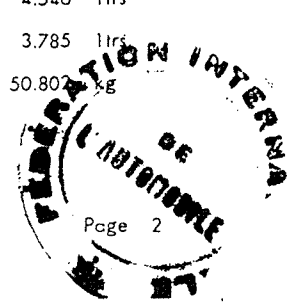

CHASSIS AND COACHWORK (Photographs A, B and C)

20. Chassis/body construction : ~~XXXXX~~ / unitary construction
21. Unitary construction, material (s) Steel
~~XXXXXXXXXXXX~~
22. Separate Constructions: Material(s) of chassis
23. Material (s) of coachwork
24. Number of doors 4 Material (s) Steel
25. Material (s) of bonnet Steel
26. Material (s) of boot lid Steel
27. Material (s) of rear-window Glass
28. Material (s) of windscreen Glass
29. Material (s) of front-door windows Glass
30. Material (s) of rear-door windows Glass
31. Sliding system of door windows Vertical (Manual)
32. Material (s) of rear-quarter light Glass

ACCESSORIES AND UPHOLSTERY

38. Interior heating : yes - ~~XXX~~ 39. Air-conditioning : ~~XXX~~ - no
40. Ventilation : yes - ~~XXX~~
41. Front seats, type of seats and upholstery Separate, Vinyl Leather
42. Weight of front seat (s), complete with supports and rails, out of the car :
15.5 x 2 = 31 kg lbs
43. Rear seats, type of seats and upholstery Bench, Vinyl Leather
44. Front bumper, material (s) Steel Weight 2.9 kg lbs
45. Rear bumper, material (s) Steel Weight 3.1 kg lbs

WHEELS

50. Type Pressed Steel
51. Weight (per wheel, without tyre) 6.0 kg lbs
52. Method of attachment 4 Hub-Bolts and Nuts
53. Rim diameter 329.4 mm 13 inches
54. Rim width 102 mm 4.0 inches

STEERING

60. Type Rack and Pinion
61. Servo-assistance : ~~XXX~~ - no
62. Number of turns of steering wheel from lock to lock 3.6
63. In case of servo-assistance



4

SUSPENSION

- 70. Front suspension (photogr. D), type Independent (Mc-Pherson)
- 71. Type of spring Coil Spring
- 72. Stabiliser (if fitted)
- 73. Number of shockabsorbers 2 74. Type Hydraulic Telescopic
- 78. Rear suspension (photogr. E), type Independent (Swing Axle)
- 79. Type of spring Leaf Spring
- 80. Stabiliser (if fitted)
- 81. Number of shockabsorbers 2 82. Type Hydraulic Telescopic

BRAKES (photographs F and G)

- 90. System Hydraulic
- 91. Servo-assistance (if fitted), type
- 92. Number of hydraulic master cylinders 2 (Tandem)

	FRONT			REAR		
	1			1		
93. Number of cylinders per wheel						
94. Bore of wheel cylinder (s)	48.1	mm	in.	20.64	mm	in.
Drum brakes						
95. Inside diameter		mm	in.	202	mm	in.
96. Length of brake linings		mm	in.	200	mm	in.
97. Width of brake linings		mm	in.	38	mm	in.
98. Number of shoes per brake				2		
99. Total area per brake		mm ²	sq. in.	15,200	mm ²	sq. in.
Disc brakes						
100. Outside diameter	230	mm	in.		mm	in.
101. Thickness of disc	9.6	mm	in.		mm	in.
102. Length of brake linings	60	mm	in.		mm	in.
103. Width of brake linings	40	mm	in.		mm	in.
104. Number of pads per brake				2		
105. Total area per brake	4,800	mm ²	sq. in.		mm ²	sq. in.



5

ENGINE (photographs J and K)

130. Cycle	4	131. Number of cylinders	4		
132. Cylinder arrangement	In Line Transverse				
133. Bore	74 mm	2.94 in.	134. Stroke	75.5 mm	2.97 in.
135. Capacity per cylinder	324.5 cm ³		19.79 cu. in.		
136. Total cylinder-capacity	1,298 cm ³		79.12 cu. in.		
137. Material (s) of cylinder block	Aluminium				
138. Material (s) of sleeves (if fitted)	Cast Iron				
139. Cylinder-head; material (s)	Aluminium		Number fitted	1	
140. Number of inlet ports	4	141. Number of exhaust ports	4		
142. Compression ratio	9.5				
143. Volume of one combustion chamber	38.2 cm ³		cu. in.		
144. Piston, material	Aluminium		145. Number of rings	3	
146. Distance from gudgeon pin centre line to highest point of piston crown	30.2 mm		inches		
147. Crankshaft : xxxxx / stamped	148. Type of crankshaft : integral xxxx				
149. Number of crankshaft main bearings	5				
150. Material of bearing cap	Aluminium				
151. System of lubrication : dry sump / xxxxxxx					
152. Capacity, lubricant	4 ltrs	pts	quarts US		
153. Oil cooler : yes / no	154. Method of engine cooling				
155. Capacity of cooling system	ltrs	pints	quarts US		
156. Cooling fan (if fitted), dia.	22 cm	inches			
157. Number of blades of cooling fan	24				

Forced Air Cooling
(By Centrifugal Fan)

Bearings

158. Crankshaft main, type	Plain Bearing	Dia.	43 mm	in.
159. Connecting rod big end,	Plain Bearing	Dia.	42 mm	in.

Weights

160. Flywheel (clean)	2.8 kg	lbs
161. Flywheel with clutch (all turning parts)	8.2 kg	lbs
162. Crankshaft	14.3 kg	lbs
163. Connecting rod	0.495 kg	lbs
164. Piston with rings and pin	0.38 kg	lbs



ENGINE ACCESSORIES

- | | | |
|---|--------------------------------------|-------------|
| 230. Fuel pump : mechanical / xx electric | 231. No. fitted | 1 |
| 232. Type of ignition system | 233. No. of distributors | 1 |
| 234. No. of ignition coils | 235. No. of spark plugs per cylinder | 1 |
| 236. Generator, type: Motor / alternator-number fitted | 237. Method of drive | V-Belt |
| 238. Voltage of generator | 239. Battery, number | 1 |
| 240. Location | | Engine Room |
| 241. Voltage of battery | | 12 volts |

ENGINE AND CAR PERFORMANCES (as declared by manufacturer in catalogue)

- | | | | | | |
|-------------------------------|------------|----------------------------|----------|-------|--------------|
| 250. Max. engine output | 100 PS | (type of horsepower: JIS) | at | 7200 | rpm |
| 251. Maximum rpm | 7700 | output at that figure | | 99 PS | |
| 252. Maximum torque | 10.95 kg-m | at | 4500 rpm | | |
| 253. Maximum speed of the car | 175 | km/hour | | | miles / hour |

255.

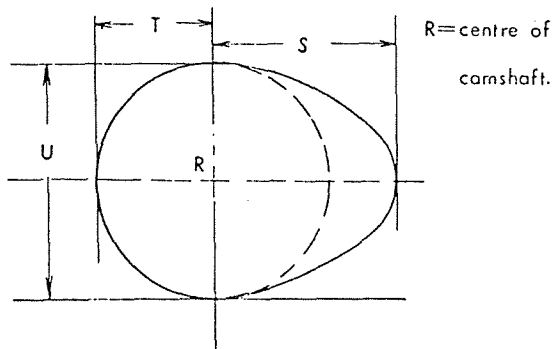

Inlet cam

S =	22.46	mm	0.88	inches
T =	16	mm	0.63	inches
U =	32	mm	1.26	inches

Exhaust cam

S =	22.46	mm	0.88	inches
T =	16	mm	0.63	inches
U =	32	mm	1.26	inches



8

Drawing inlet manifold ports, side of cylinder-head. Indicate scale or dimensions and manufacturing tolerance.

Unit : mm

Tolerance : ± 1.5

Drawing of entrance to inlet port of cylinder-head. Indicate scale or dimensions and manufacturing tolerance.

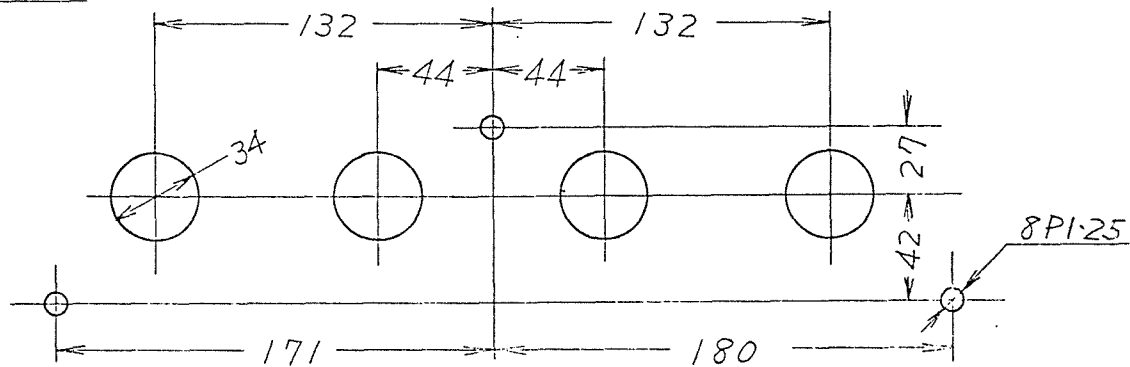

Drawing exhaust manifold ports, side of cylinder-head. Indicate scale or dimensions and manufacturing tolerance.

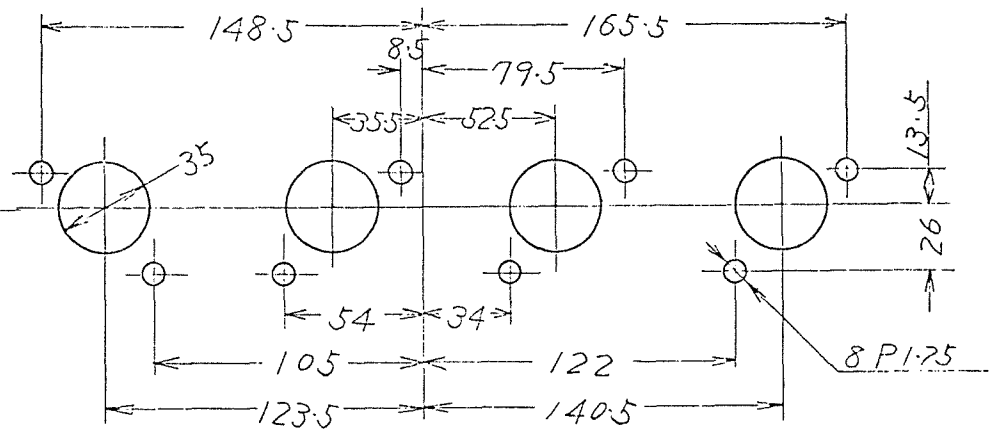

Drawing of exit to exhaust port of cylinderhead. Indicate scale or dimensions and manufacturing tolerance.



DRIVE TRAIN

CLUTCH

- 260. Type of clutch **Dry**
- 261. No. of plates **1**
- 262. Dia. of clutch plates **18.4** cm inches
- 263. Dia. of linings, inside **12.7** cm in. outside **18.4** cm in.
- 264. Method of operating clutch **Wire**

GEAR BOX (photograph H)

- 270. Manual type, make **HONDA MOTOR CO., LTD.** Method of operation **Mechanical**
- 271. No. of gear-box ratios forward **4**
- 272. Synchronized forward ratios **1, 2, 3 and 4**
- 273. Location of gear-shift **Floor**
- 274. Automatic, make _____ type
- 275. No. of forward ratios _____
- 276. Location of gear-shift _____

277.	Manual			Automatic			Alternative manual/automatic		
	Ratio	No.	teeth	Ratio	No.	teeth	Ratio	No.	teeth
1	4.27	$\frac{31}{25}$	$\frac{32}{26}$ $\frac{42}{15}$						
2	2.49	$\frac{31}{25}$	$\frac{32}{26}$ $\frac{36}{22}$						
3	1.69	$\frac{31}{25}$	$\frac{32}{26}$ $\frac{30}{27}$						
4	1.52	$\frac{31}{25}$	$\frac{32}{26}$						
5									
6									
reverse	4.57	$\frac{31}{25}$	$\frac{32}{26}$ $\frac{42}{14}$						

- 278. Overdrive, type _____
- 279. Forward gears on which overdrive can be selected _____
- 280. Overdrive ratio _____

FINAL DRIVE

- 290. Type of final drive **Herical Gear**
- 291. Type of differential **Bevel Gear**
- 292. Type of limited slip differential (if fitted) _____
- 293. Final drive ratio **3.50**
- Number of teeth **70/20**



IMPORTANT- The conformity of the car with the following items of the present recognition form is to be disregarded during the scrutineering, when the vehicle has been entered in group 2 (Touring cars) or 3 (Grand Touring cars): 41, 72, 80, 91, 142, 143, 144, 145, 146, 153, 156, 157, 160, 161, 162, 163, 164, 182, 184, 186, 187, 188, 189, 199, 201, 202, 203, 212, 213, 215, 216, 222, 225, 230, 250, 251, 252, 253, and photographs I, M, N, and page 8

During the scrutineering of cars entered in group 4 (Sportscars) only the following items of the present recognition form are to be taken into consideration: 1, 2, 3, 9, 20, 21, 22, 23, 24, 25, 26, 70, 71, 78, 79, 90, 130, 131, 132, 133, 134, 135, 136, 137, 138, 139, 140, 141, 147, 148, 149, 150, 158, 159, 170, 171, 172, 173, 185, 200, 270, 271, 274, 275, 290, 291, 292 and photographs A, B, D, E, F, G, H, J, K, and O.

Optional equipment affecting preceding information. This to be stated together with reference number.

I) WHEEL

- | | | | | | |
|----|-----|----------------------|----------------------|-----------|--|
| 1) | 50) | Type | Pressed Steel | | |
| | 51) | Weight | 6.5 kg | | |
| | 52) | Method of Attachment | 4 Hub-Bolts and Nuts | | |
| | 53) | <u>Rim Diameter</u> | 329.4 mm | 13 inches | |
| | 54) | <u>Rim Width</u> | 127 mm | 5 inches | |
| 2) | 50) | Type | Magnesium Casting | | |
| | 51) | Weight | 4.8 kg | | |
| | 52) | Method of Attachment | 4 Hub-Bolts and Nuts | | |
| | | | or | | |
| | | | Center Lock | | |
| | 53) | <u>Rim Diameter</u> | 329.4 mm | 13 inches | |
| | 54) | <u>Rim Width</u> | 203 mm | 8 inches | |

II) FRONT WING

- | | | | |
|--|-----|---------------------------|--------------------|
| | 5) | Over All Width of the Car | 156.5 cm |
| | 21) | Materials | Steel or Aluminium |

III) HOOD

- | | | | |
|--|-----|-----------|-------|
| | 21) | Materials | Steel |
|--|-----|-----------|-------|



//

Make HONDA MOTOR CO., LTD.

Model H 1300

F. I. A. Rec. No

Photograph

interior view of car through driver's door (open or removed) with dashboard

B. 3/4 view of car from rear

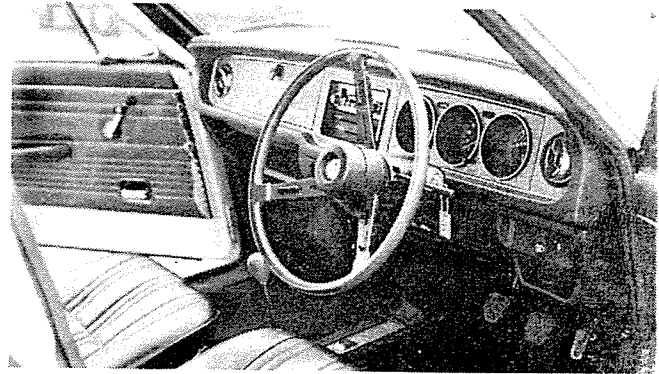

D, front axle complete, removed from car. Without wheels.

E, Rear axle complete without wheels, removed from car.

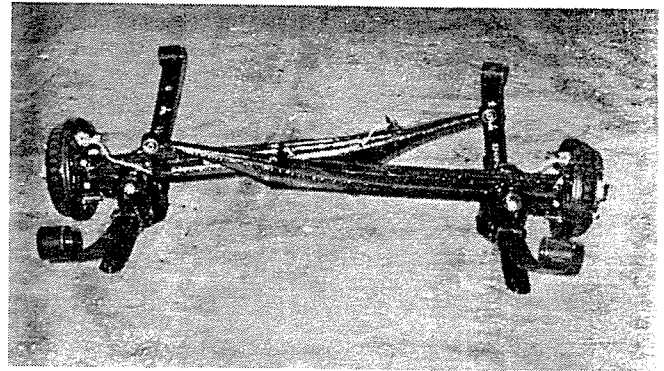
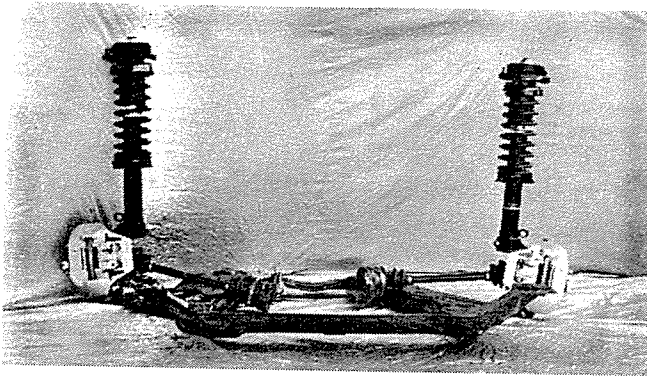

F, front brake. drum removed or disc with caliper(s)

G, rear brake. drum removed or disc with caliper(s)

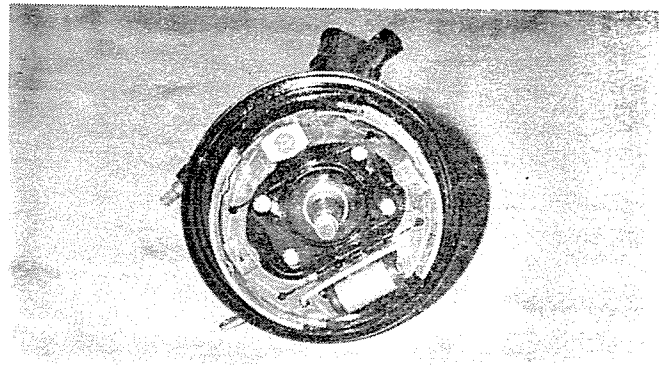
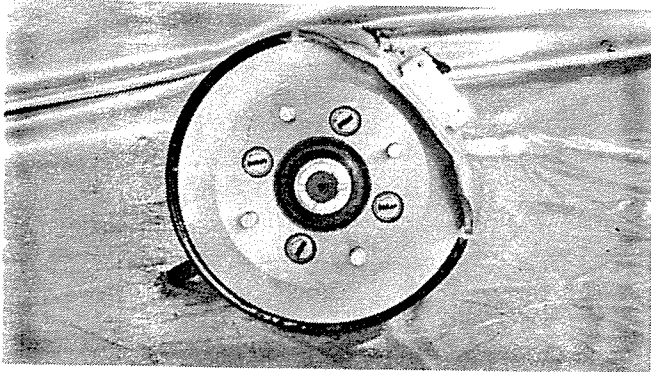

H, gear-box, view from side

I, silencer + exhaust pipes after exhaust manifold.

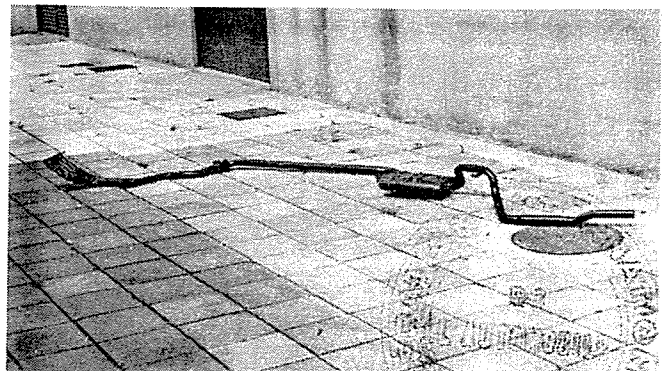
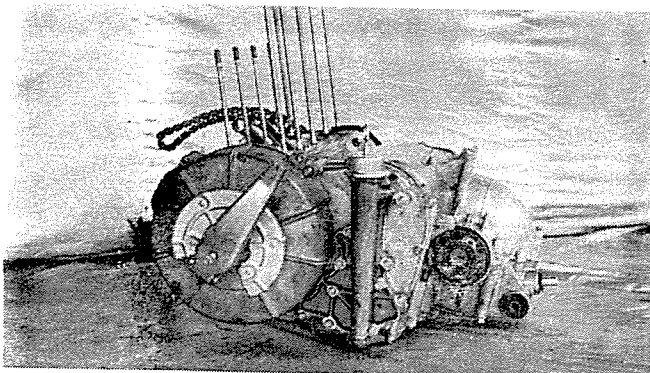

Make HONDA MOTOR CO., LTD.

J, engine unit out of car, from right. With clutch and accessories but without air filter nor gear-box.

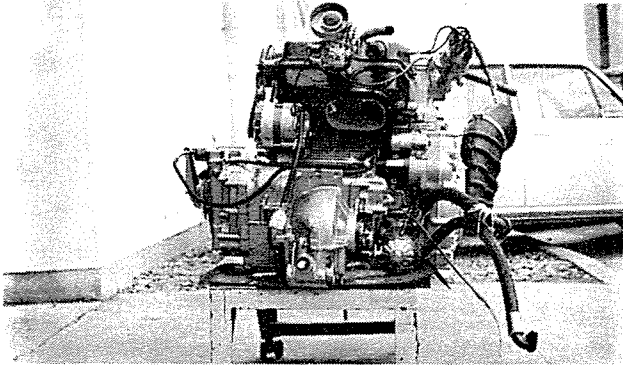

Model H 1300

F.I.A. Rec. No

K, engine unit out of car, from left. With clutch and accessories but without gear-box nor air filter.

Photograph

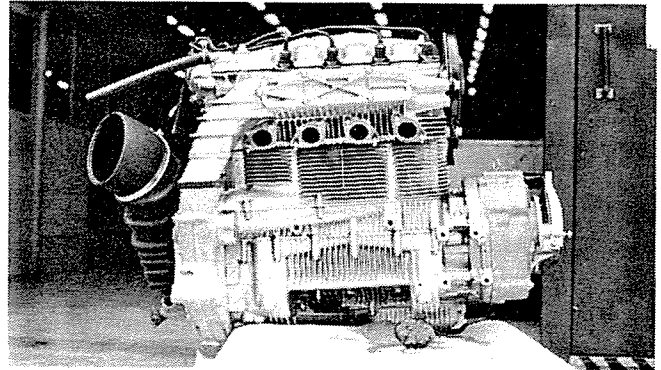

L, combustion chamber

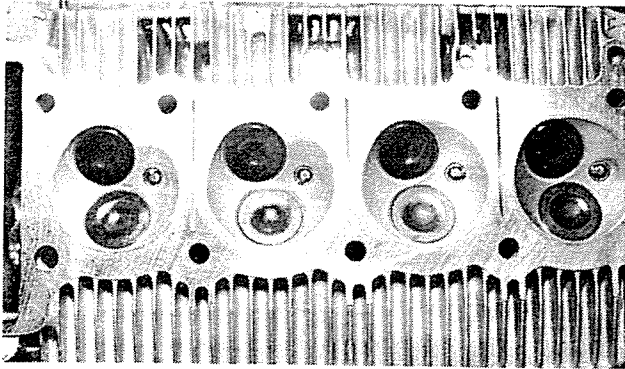

M, piston crown

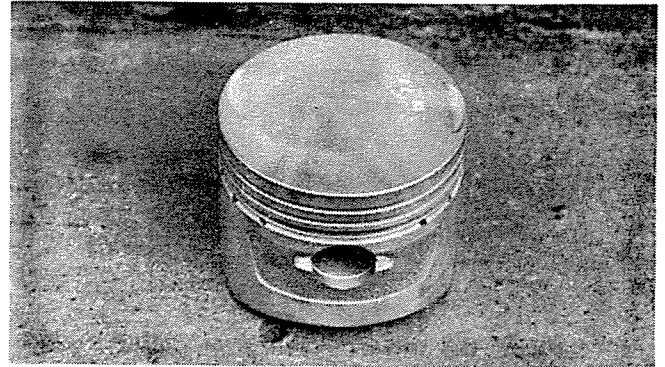

N, Carburettor (view from side of manifold)

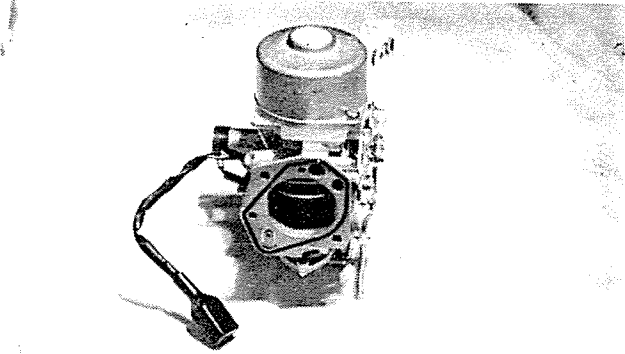

O, engine in car with all accessories, bonnet open or removed.

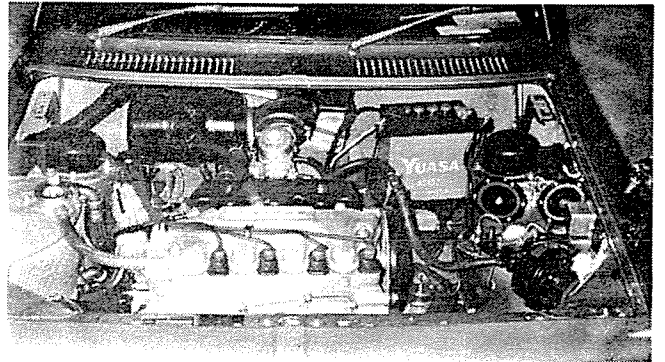

P, inlet manifold

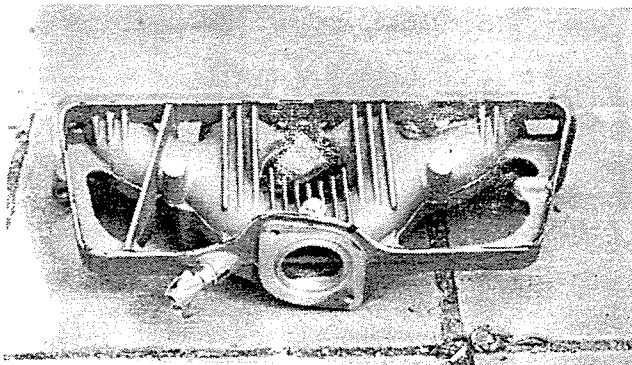

Q, exhaust manifold

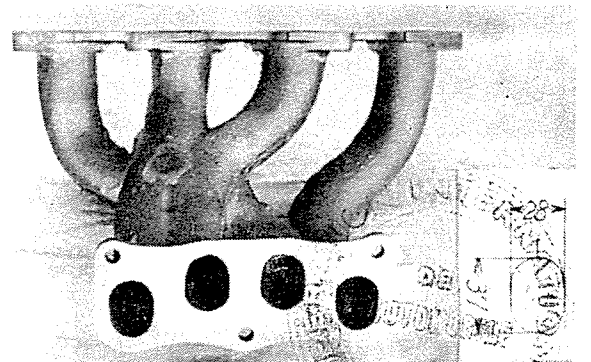

DIMENSIONS OF INTERIOR
(Conform to Art. 253 b of Appendix J)

For four seaters :

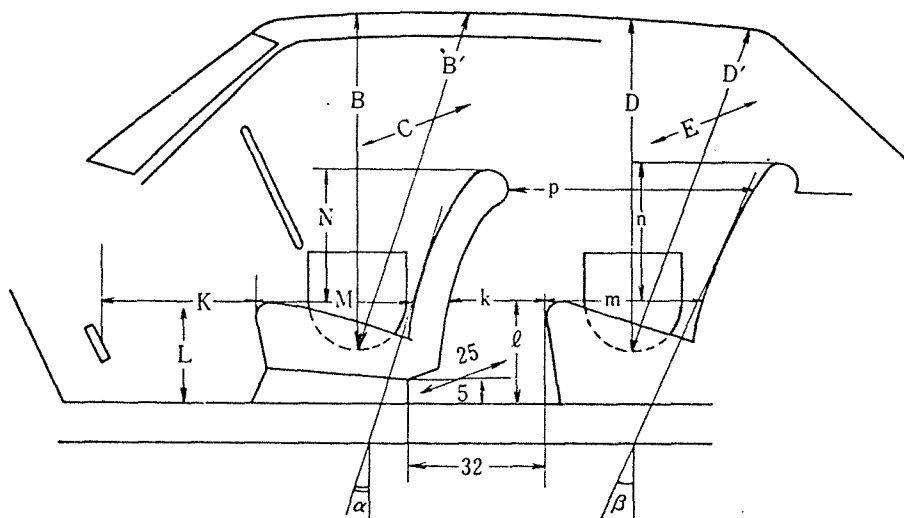

Minimum Dimensions (cm)							
B	B'	α	C	D	D'	β	E
87	97	22°	122	85.5	92	21.5°	122

Minimum Dimensions (cm)										
L	ℓ	M	m	N	n	k+m	p	k	k+ ℓ +m	K+L+M
33.5	30.5	47.5	44.5	43.5	38.5	75.5	77	31	106	133
0.9L = 30.2		0.85M = 40.4		0.8N = 34.8		0.8(k+m) = 60.4		(15)	(95)	(120)

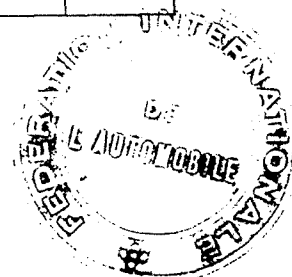

Make HONDA MOTOR CO., LTD.

Model H 1300

F. I. A. Rec. No.

TWO STROKE ENGINES

300. System of cylinder scavenging
301. Type of lubrication
302. Inlet ports, length measured around cylinder wall mm inches
303. Height inlet port mm in. 304. Area mm² sq. in.
305. Exhaust ports, length measured around cylinder wall mm inches
306. Height exhaust port mm in. 307. Area mm² sq. in.
308. Transfer port, length measured around cylinder wall mm inches
309. Height transfer port mm in. 310. Area mm² sq. in.
311. Piston ports, length measured around piston mm inches
312. Height piston port mm in. 313. Area mm² sq. in.
314. Method of precompression 315. Precompression cyl.: yes/no
316. Bore mm inches 317. Stroke mm inches
318. Distance from top of cyl. block to highest point of exhaust port : mm inches
319. Distance from top of cyl. block to lowest point of inlet port : mm inches
320. Distance from top of cyl. block to highest point of transfer port : mm inches
321. Drawing of cylinder ports.

330. Supercharging—state full details hereafter :

JAPAN AUTOMOBILE FEDERATION



Yasuharu Nanba





HONDA

HONDA MOTOR CO., LTD.

No. 5, 5-chome, Yaesu, Chuo-ku, Tokyo, Japan

Cable Address / HONDAMOTOR TOKYO

Tel. / (272) 4411

Telex / TK2678 HONDAMTR

Relation of 8" rim wheel and optional front wing for standard wheel

Unit : mm

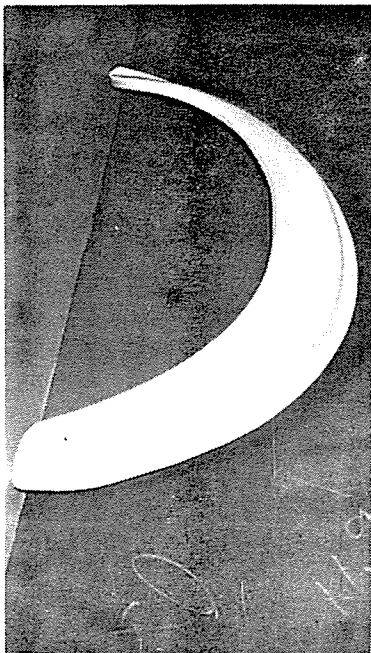
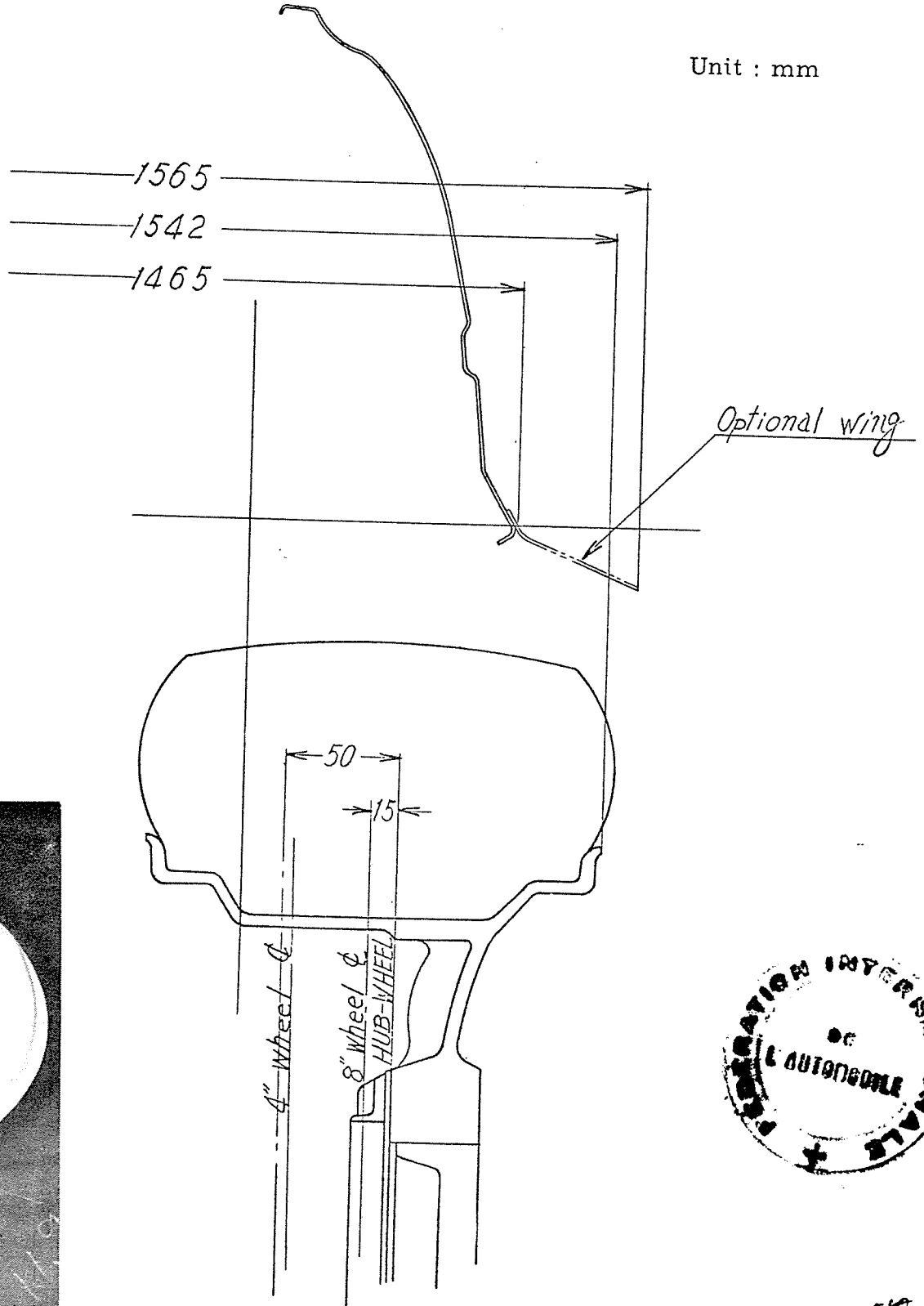



HONDA

HONDA MOTOR CO., LTD.

No. 5, 5-chome, Yaesu, Chuo-ku, Tokyo, Japan
Cable Address / HONDAMOTOR TOKYO
Tel. / (272) 4411
Telex / TK2678 HONDAMTR

Optional Hood with air outlet

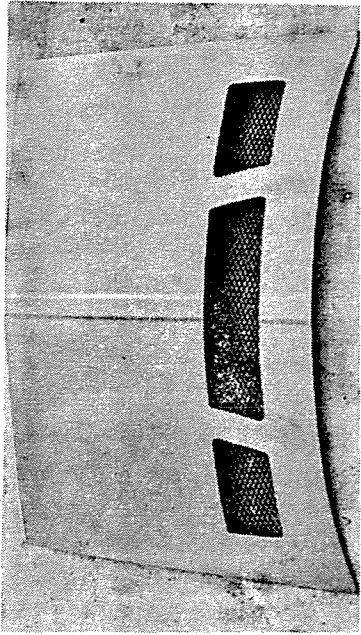
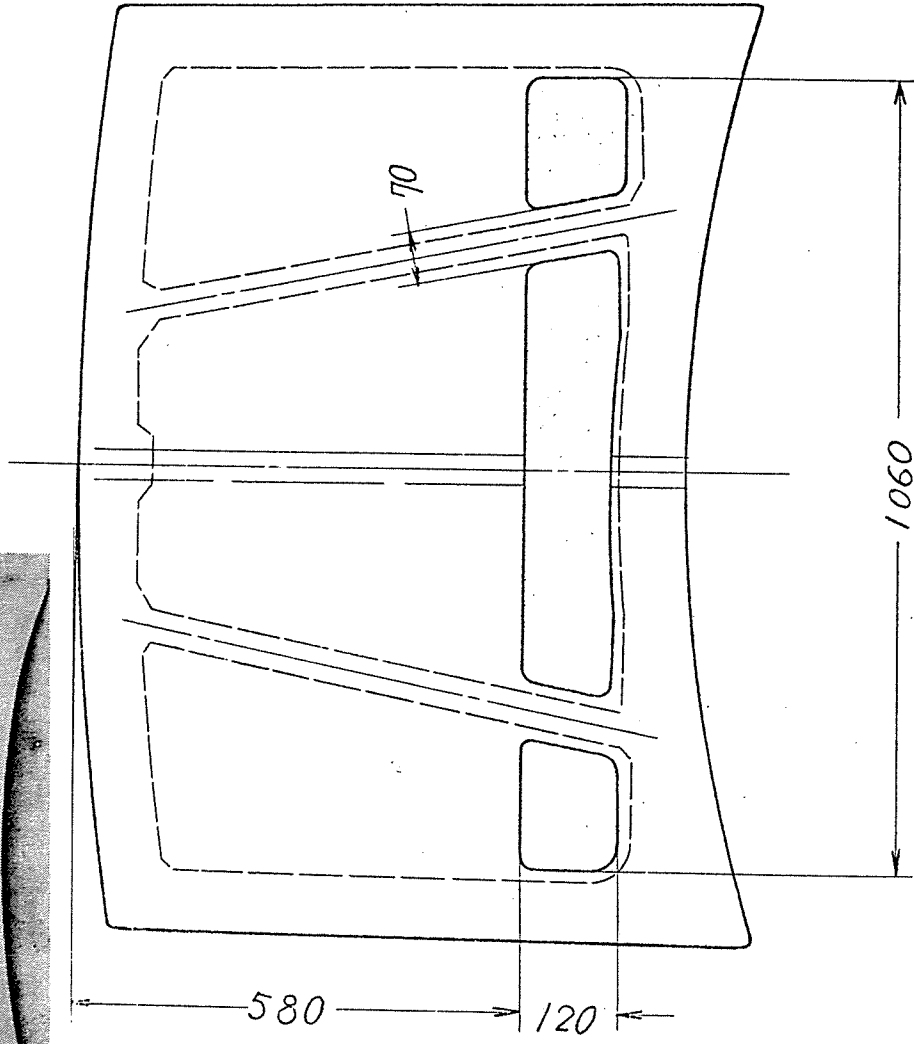

Unit : mm

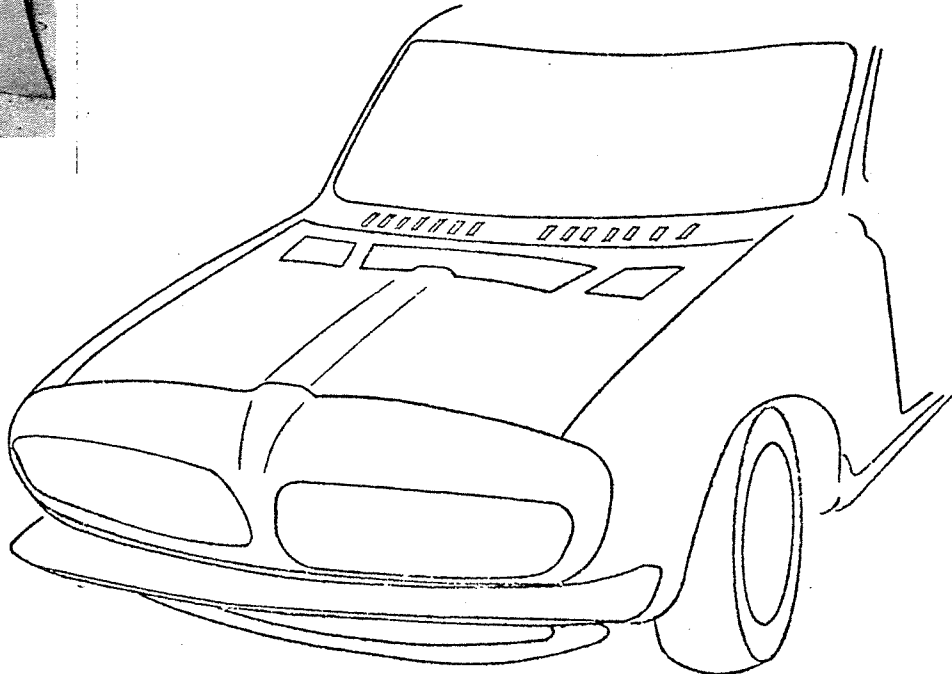



FEDERATION INTERNATIONALE DE L'AUTOMOBILE

Amendment to Form of Recognition in accordance with the International Sporting Code.

Make HONDA MOTOR CO., LTD. Model H1300

Modification's application starts with serial No. chassis H1300-1000001 engine H1300E-1000001

Application of this amendment started the

Commercial denomination after application of modifications

The modifications are to be considered as: Variant / ~~XXXXXXXXXXXXXXXXXXXX~~

Date amendment is valid from 1/7/70 List 70/7

Description of amendment

Another type of engine can be choiced for the H1300 cars as maker's option.

- 142. Compression ratio 9.3
143. Volume of one combustion chamber 39.1 cm^3
146. Distance from gudgeon pin centre line to highest point of piston crown 30.7 mm
182. Max valve lift 10.0 mm 0.39 in.
187. Valves open at (with tolerance for tappet clearance indicated) B. T. D. C. 5°+7°
188. Valves close at (with tolerance for tappet clearance indicated) A. B. D. C. 40°+7°
197. Max valve lift 10.0 mm 0.39 in.
202. Valves open at (with tolerance for tappet clearance indicated) B. B. D. C. 40°+7°
203. Valves close at (with tolerance for tappet clearance indicated) A. T. D. C. 5°+7°
210. Number of carburettors fitted 4
213. Model 1000-376
250. Max engine output 110 PS (type of horsepower : JIS) at 7300 rpm
251. Maximum rpm 7,800 output at that figure 105 PS

Stamp and signature of National Sporting Authority

Stamp and signature of F.I.A.

JAPAN AUTOMOBILE FEDERATION

Handwritten signature of Yasuharu Namba

Stamp of F.I.A. with signature and page number

Make HONDA MOTOR CO., LTD.

Model H1300

F.I.A. Rec. No

252. Maximum torque 11.5 kgm at 5000 rpm
253. Maximum speed of the car 180 km/hour
255. Inlet cam S = 23.05 mm 0.92 in.
Exhaust cam S = 23.05 mm 0.92 in.

A. Photo

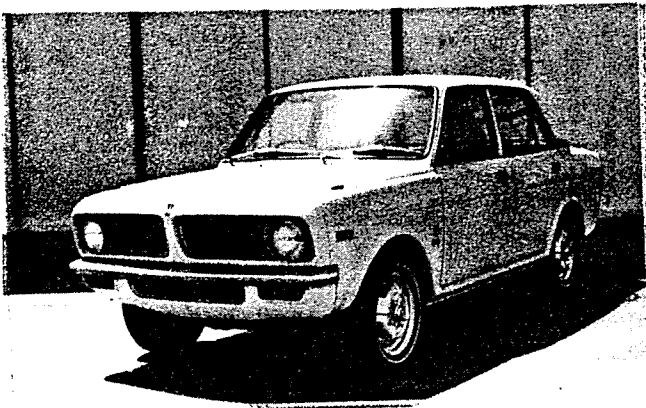

B. Photo

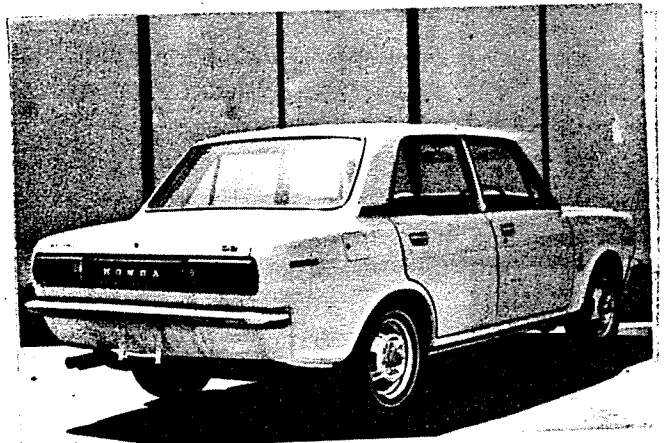

I. Photo

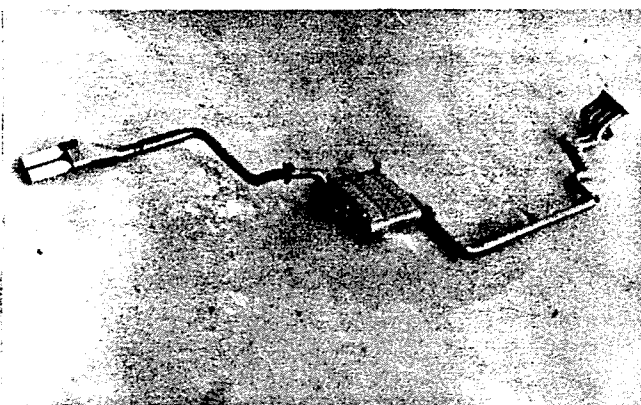

J. Photo

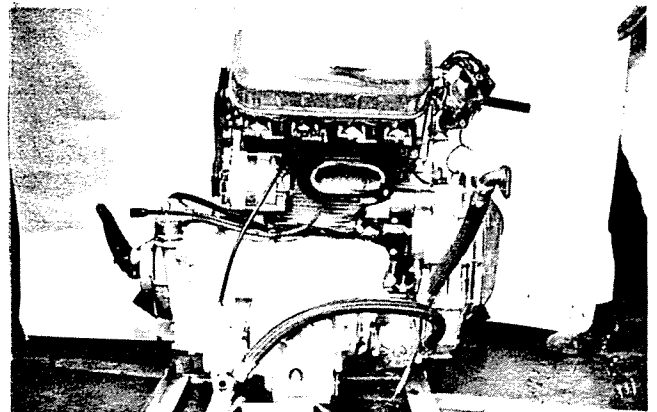

Make HONDA MOTOR CO., LTD.

Model H1300

F.I.A. Rec. No.
1577/1115

K. Photo

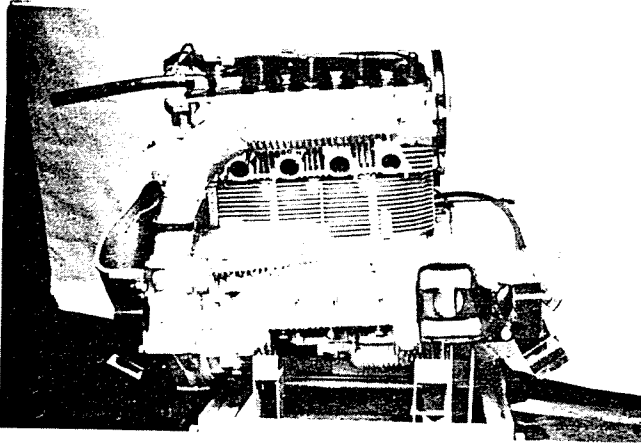

N. Photo

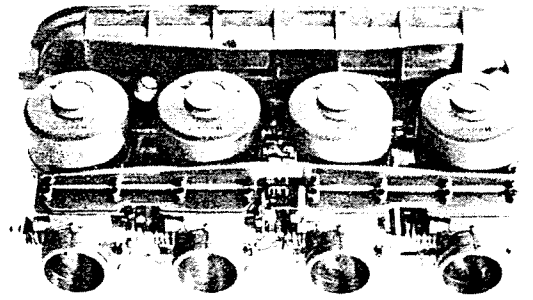

O. Photo

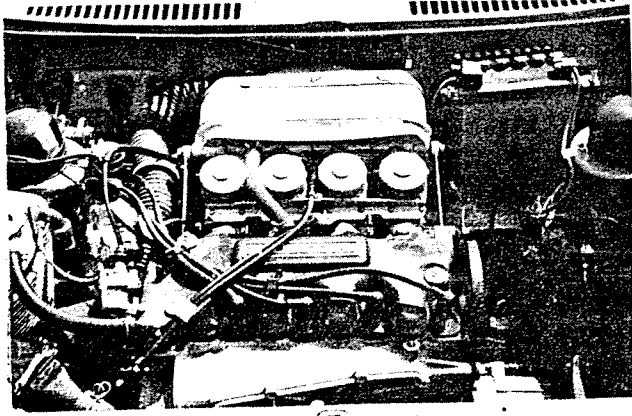

P. Photo

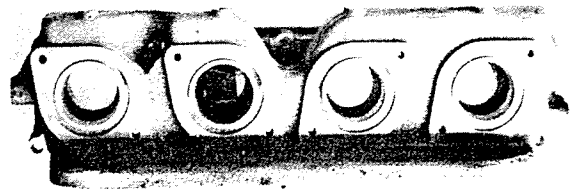

REAR WING EXTENSION

5. Overall width of the car 156.5 cm

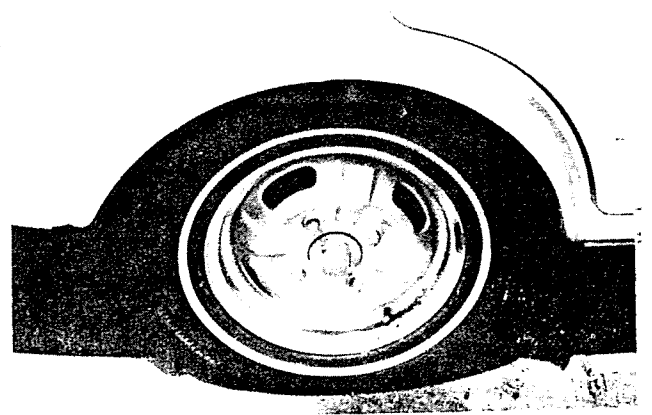
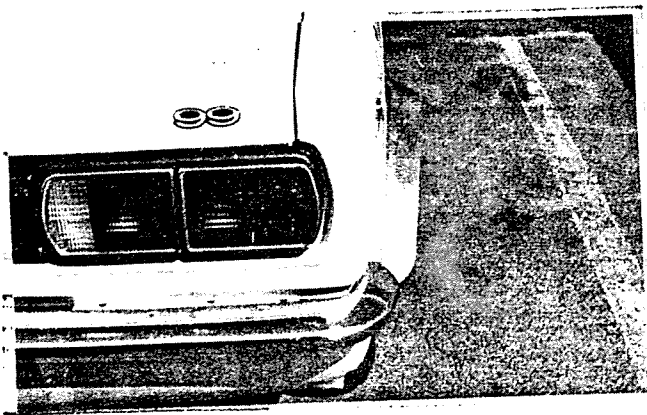

Relation of 7" wheel rim and optional Rear Wing extension for standard wheel

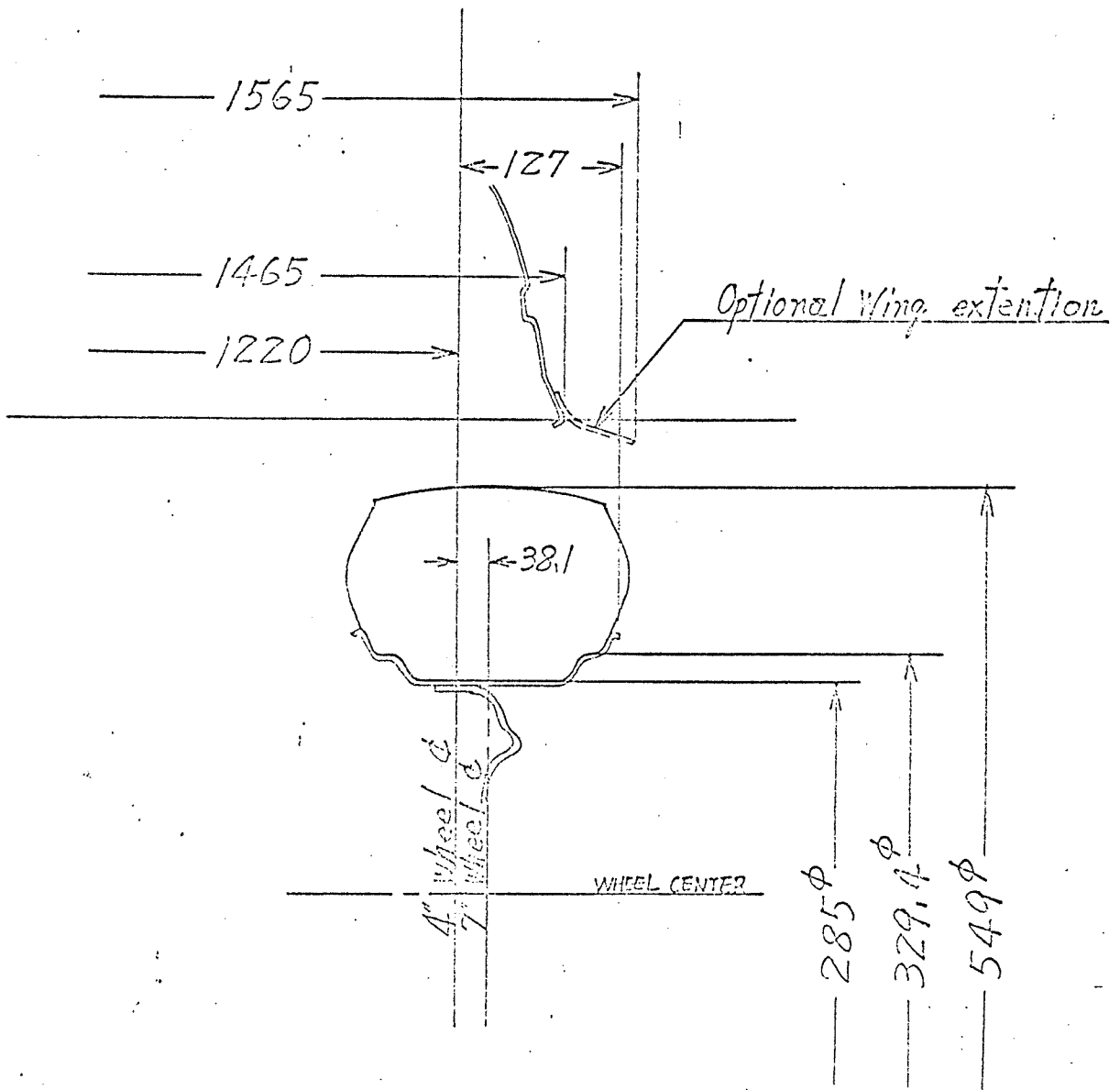

HONDA MOTOR CO.
Page 436 0 411.5