



JAPAN AUTOMOBILE FEDERATION

F. I. A. Recognition No. 1583
Group 2

FEDERATION INTERNATIONALE DE L'AUTOMOBILE

Form of recognition in accordance with
Appendix J to the International Sporting Code.

Manufacturer	Isuzu Motors Limited	Cylinder-capacity	1584 cm ³ 96.66 cu in
Serial No. of chassis	PR50-4097363	Model	Isuzu PR50SD (Bellett1600S)
Serial No. of engine	G161-313182	Manufacturer	Isuzu Motors Limited
Recognition is valid from	-1/4/70	Manufacturer	Isuzu Motors Limited
		List	70/4

The manufacturing of the model described in this recognition form was started on January 19 69 and the minimum production of 1000 identical cars, in accordance with the specifications of this form was reached on May 19 69.

Photograph A, 3/4 view of car from front



The vehicle described in this form has been subject to the following amendments :

Variants

on	19	rec. No.	List
on	19	rec. No.	List
on	19	rec. No.	List
on	19	rec. No.	List
on	19	rec. No.	List

Normal evolution of the type

on	19	rec. No.	List
on	19	rec. No.	List
on	19	rec. No.	List
on	19	rec. No.	List
on	19	rec. No.	List

Stamp and signature of the
National Sporting Authority

Stamp and signature of the F. I. A.

Page 1

Make **ISUZU**

Model **PR50SD**

F. I. A. Rec. No.

IMPORTANT - the underlined items must be stated in two measuring systems, one of which must be the metric system. See conversion table hereafter.

CAPACITIES AND DIMENSIONS

1. <u>Wheelbase</u>	2350	mm	92.5	inches
2. <u>Front track</u>	1245	mm	49.0	inches *
3. <u>Rear track</u>	1195	mm	47.0	inches *
4. Overall length of the car	401.5	cm		inches
5. Overall width of the car	149.5	cm		inches
6. Overall height of the car	139.0	cm		inches
7. <u>Capacity of fuel tank</u> (reserve included)			40	ltrs
	10.5	Gallon US		Gallon Imp.
8. Seating capacity	5			
9. <u>Weight</u> , total weight of the car with normal equipment, water, oil and spare wheel but without fuel nor repair tools:				
	870	kg	1920	lbs
				cwt

* Differences in track caused by the use of other wheels with different rim widths must be stated when recognition is requested for the wheels concerned.

Specify ground clearance in relation to the track and give drawing of two fixed points of the vehicle's structure at which measurements are taken.

These ground clearance dimensions are only for information when checking the track and can in no way affect the eligibility of the car.

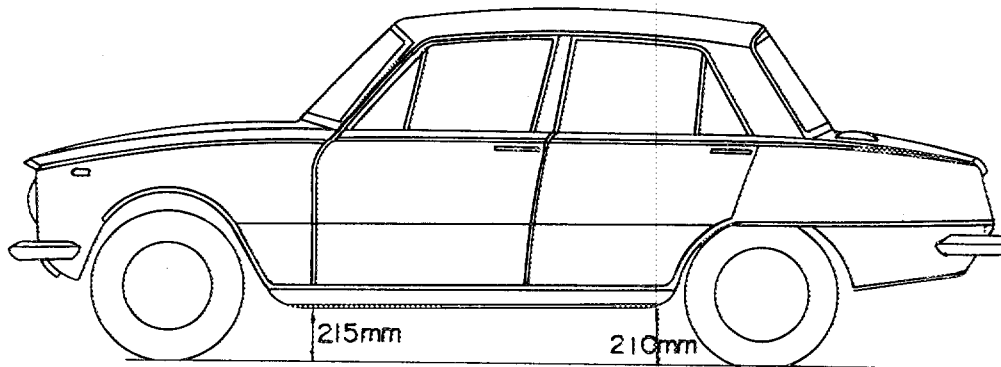

CONVERSION TABLE

1 inch / pouce	-- 2.54 cm	1 quart US	-- 0.9464 ltrs
1 foot / pied	-- 30.4794 cm	1 pint (pt)	-- 0.568 ltrs
1 square inch / pouce carré	-- 6.452 cm ²	1 gallon imp.	-- 4.546 ltrs
1 cubic inch / pouce cube	-- 16.387 cm ³	1 gallon US	-- 3.785 ltrs
1 pound / livre (lb)	-- 453.593 gr.	1 hundred weight (cwt)	-- 50.802 kg

Make ISUZU

Model PR50SD

F. I. A. Rec. No.

CHASSIS AND COACHWORK (Photographs A, B and C)

20. Chassis/body construction : ~~Separate~~ / unitary construction
21. Unitary construction, material (s) **Steel**
Separate construction
22. Separate Constructions: Material (s) of chassis
23. Material (s) of coachwork
24. Number of doors **4** Material (s) **Steel**
25. Material (s) of bonnet **Steel**
26. Material (s) of boot lid **Steel**
27. Material (s) of rear-window **Glass**
28. Material (s) of windscreen **Glass**
29. Material (s) of front-door windows **Glass**
30. Material (s) of rear-door windows **Glass**
31. Sliding system of door windows **Vertical, Manual**
32. Material (s) of rear-quarter light

ACCESSORIES AND UPHOLSTERY

38. Interior heating : ~~Yes~~ - no
39. Air-conditioning : ~~Yes~~ - no
40. Ventilation : yes - ~~no~~
41. Front seats, type of seats and upholstery **Separate, Vinyl**
42. Weight of front seat (s), complete with supports and rails, out of the car :
12.5 kg x 2 lbs
43. Rear seats, type of seats and upholstery **Bench, Vinyl**
44. Front bumper, material (s) **Steel** Weight **6.0 kg** lbs
45. Rear bumper, material (s) **Steel** Weight **6.0 kg** lbs

WHEELS

50. Type **Pressed steel**
51. Weight (per wheel, without tyre) **6.0 kg** lbs
52. Method of attachment **4 nuts**
53. Rim diameter **330.2 mm** **13.0 inches**
54. Rim width **114.3 mm** **4.5 inches**

STEERING

60. Type **Rack and pinion**
61. Servo-assistance : ~~Yes~~ - no
62. Number of turns of steering wheel from lock to lock **2.9**
63. In case of servo-assistance

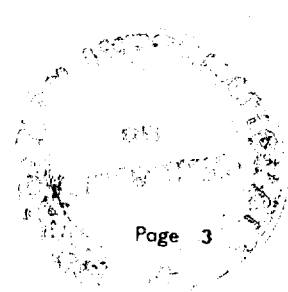

SUSPENSION

- 70. Front suspension (photogr. D), type Independent, Wishbone
- 71. Type of spring Coil
- 72. Stabiliser (if fitted) Torsion bar
- 73. Number of shockabsorbers 2
- 74. Type Hydraulic telescopic
- 78. Rear suspension (photogr. E), type Independent, Swing axle
- 79. Type of spring Coil and Transverse Leaf
- 80. Stabiliser (if fitted)
- 81. Number of shockabsorbers 2
- 82. Type Hydraulic telescopic

BRAKES (photographs F and G)

- 90. System Hydraulic
- 91. Servo-assistance (if fitted), type
- 92. Number of hydraulic master cylinders 1

	FRONT		REAR	
93. Number of cylinders per wheel	2		1	
94. Bore of wheel cylinder (s)	57.2	mm in.	22.2	mm in.
Drum brakes				
95. Inside diameter		mm in.	203.2	mm in.
96. Length of brake linings		mm in.	195.0	mm in.
97. Width of brake linings		mm in.	37.1	mm in.
98. Number of shoes per brake			2	
99. Total area per brake		mm ² sq. in.	14,430	mm ² sq. in.
Disc brakes				
100. Outside diameter	237	mm in.		mm in.
101. Thickness of disc	10	mm in.		mm in.
102. Length of brake linings	60	mm in.		mm in.
103. Width of brake linings	45	mm in.		mm in.
104. Number of pads per brake			2	
105. Total area per brake	5,400	mm ² sq. in.		mm ² sq. in.

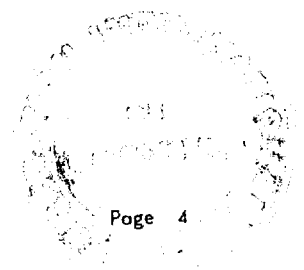

Make ISUZU

Model PR50SD

F. I. A. Rec. No.

ENGINE (photographs J and K)

- 130. Cycle 4
- 131. Number of cylinders 4
- 132. Cylinder arrangement In-line
- 133. Bore 82 mm 3.228 in.
- 134. Stroke 75 mm 2.953 in.
- 135. Capacity per cylinder 396 cm³ 24.17 cu. in.
- 136. Total cylinder-capacity 1584 cm³ 96.68 cu. in.
- 137. Material (s) of cylinder block Cast iron
- 138. Material (s) of sleeves (if fitted)
- 139. Cylinder-head, material (s) Aluminum Number fitted 1
- 140. Number of inlet ports 4
- 141. Number of exhaust ports 4
- 142. Compression ratio 9.3
- 143. Volume of one combustion chamber 47.7 cm³ cu. in.
- 144. Piston, material Aluminum
- 145. Number of rings 3
- 146. Distance from gudgeon pin centre line to highest point of piston crown 42.2 mm inches
- 147. Crankshaft : ~~cast iron~~ stamped
- 148. Type of crankshaft : integral ~~XXXXXX~~
- 149. Number of crankshaft main bearings 5
- 150. Material of bearing cap Cast iron
- 151. System of lubrication : ~~XXXXXX~~ oil in sump
- 152. Capacity, lubricant 3.2 ltrs pts quarts US
- 153. Oil cooler : ~~XXX~~ / no
- 154. Method of engine cooling Water
- 155. Capacity of cooling system 5.7 ltrs pints quarts US
- 156. Cooling fan (if fitted), dia. 32 cm inches
- 157. Number of blades of cooling fan 4

Bearings

- 158. Crankshaft main, type Plain Dia. 56 mm in.
- 159. Connecting rod big end, Plain Dia. 49 mm in.

Weights

- 160. Flywheel (clean) 6.0 kg lbs
- 161. Flywheel with clutch (all turning parts) 11.1 kg lbs
- 162. Crankshaft 15.3 kg
- 163. Connecting rod 0.59 kg lbs
- 164. Piston with rings and pin 0.515 kg lbs



Make **Isuzu**

Model **PR50SD**

F. I. A. Rec. No.

FOUR STROKE ENGINES

170. Number of camshafts **1** 171. Location **Cylinder block**
172. Type of camshaft drive **Chain**
173. Type of valve operation **Push rod**

INLET (see page 8) *

180. Material(s) of inlet manifold **Aluminum**
181. Diameter of valves **41 mm** **1.614 inches**
182. Max. valve lift **9.3 mm** **0.366 in.** 183. Number of valve springs **2**
184. Type of spring **Coil** 185. Number of valves per cylinder **1**
186. Tappet clearance for checking timing (cold) **0.30 mm** inches
187. Valves open at (with tolerance for tappet clearance indicated) **B.T.D.C 38° ± 3°**
188. Valves close at (with tolerance for tappet clearance indicated) **A.B.D.C 82° ± 3°**
189. Air filter, type **Dry**

EXHAUST (see page 8)

195. Material (s) of exhaust manifold **Steel**
196. Diameter of valves **36 mm** **1.417 inches**
197. Max. valve lift **9.3 mm** **0.366 in.** 198. Number of valve springs **2**
199. Type of spring **Coil** 200. Number of valves per cylinder **1**
201. Tappet clearance for checking timing (cold) **0.35 mm** inches
202. Valves open at (with tolerance for tappet clearance indicated) **B.B.D.C 73° ± 3°**
203. Valves close at (with tolerance for tappet clearance indicated) **A.T.D.C 35° ± 3°**

CARBURETION (photograph N)

210. Number of carburetors fitted **2** 211. Type **Side draught (SU)**
212. Make **Hitachi** 213. Model **HJD 38W**
214. Number of mixture passages per carburetor
215. Flange hole diameter of exit port(s) of carburetor **38 mm** inches
216. Minimum dimensions of mixture passage(s) with piston at max. height (example: SU) **29 mm** inches

INJECTION (if fitted)

220. Make of pump 221. Number of plungers
222. Model or type of pump 223. Total number of injectors
224. Location of injectors
225. Minimum diameter of inlet pipe mm inches

*) for additional information concerning two-stroke engines and super-charged engines see page 13.

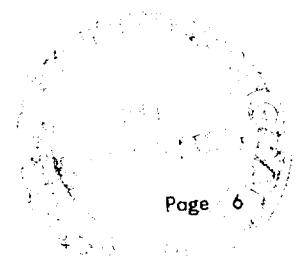

Make **Isuzu**

Model **PR50SD**

F. I. A. Rec. No.

ENGINE ACCESSORIES

- 230. Fuel pump : mechanical ~~XXXXXX~~
- 232. Type of ignition system **Make and break**
- 234. No. of ignition coils **1**
- 236. Generator, type: ~~XXXXXX~~/alternator-number fitted **1**
- 238. Voltage of generator **12** volts
- 240. Location **Engine room**
- 241. Voltage of battery **12** volts

- 231. No. fitted **1**
- 233. No. of distributors **1**
- 235. No. of spark plugs per cylinder **1**
- 237. Method of drive **V belt**
- 239. Battery, number **1**

ENGINE AND CAR PERFORMANCES (as declared by manufacturer in catalogue)

- 250. Max. engine output **90PS** (type of horsepower. **JIS**) at **5,400** rpm
- 251. Maximum rpm **5,400** output at that figure **90PS**
- 252. Maximum torque **13.0 kg-m** at **4,200** rpm
- 253. Maximum speed of the car **160** km/hour **miles / hour**

255.

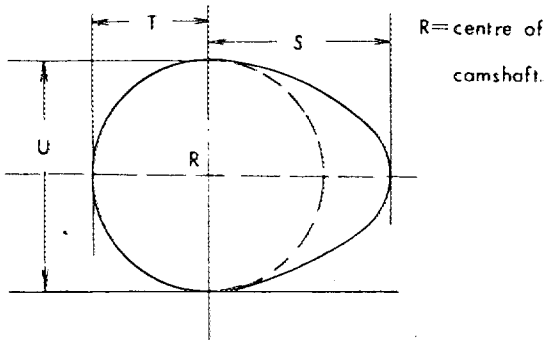

Inlet cam

S =	21.5	mm	0.845	inches
T =	14.6	mm	0.575	inches
U =	29.3	mm	1.155	inches

Exhaust cam

S =	21.5	mm	0.845	inches
T =	14.6	mm	0.575	inches
U =	29.3	mm	1.155	inches

Make ISUZU

Model PR50SD

F. I. A. Rec. No

Engine center

Drawing inlet manifold ports, side of cylinder-head. Indicate scale or dimensions and manufacturing tolerance.

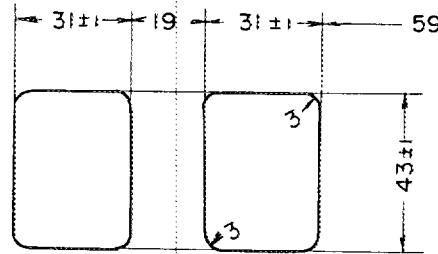

Drawing of entrance to inlet port of cylinder-head. Indicate scale or dimensions and manufacturing tolerance.

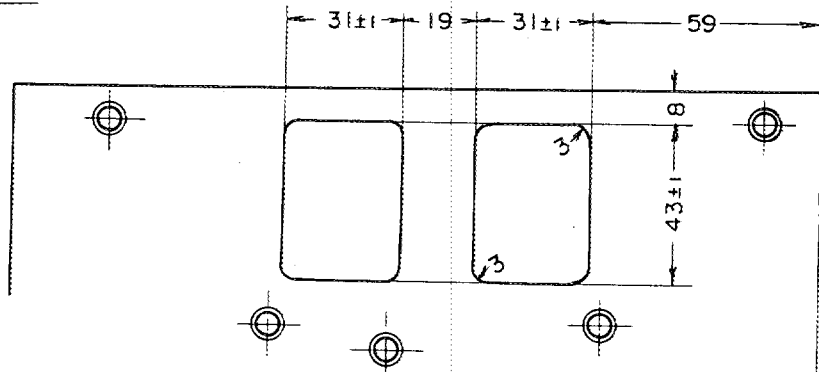

Drawing exhaust manifold ports, side of cylinder-head. Indicate scale or dimensions and manufacturing tolerance.

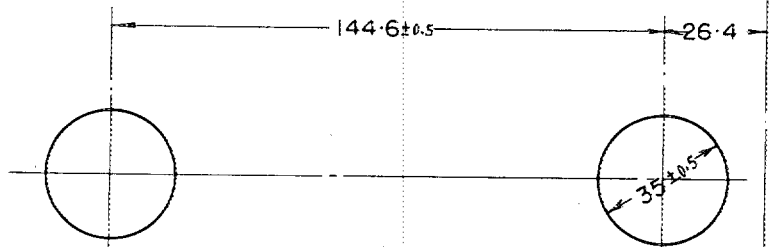

Drawing of exit to exhaust port of cylinderhead. Indicate scale or dimensions and manufacturing tolerance.

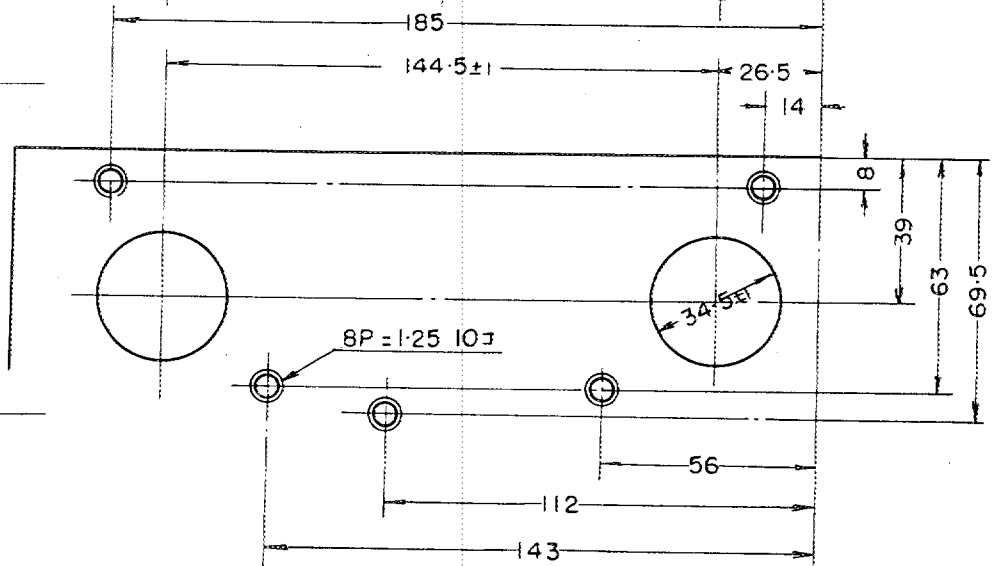

Unit: mm

Make ISUZU

Model PR50SD

F. I. A. Rec. No.

DRIVE TRAIN

CLUTCH

- 260. Type of clutch **Dry plate** 261. No. of plates **1**
- 262. Dia. of clutch plates **20.3** cm inches
- 263. Dia. of linings, inside **14.6** cm in. outside **20.3** cm in.
- 264. Method of operating clutch **Mechanical**

GEAR BOX (photograph H)

- 270. Manual type, make **Isuzu** Method of operation **Mechanical**
- 271. No. of gear-box ratios forward **4** 272. Synchronized forward ratios **1, 2, 3 & 4**
- 273. Location of gear-shift **Floor**
- 274. Automatic, make type
- 275. No. of forward ratios 276. Location of gear-shift

277.	Manual		Automatic		Alternative manual		Automatic	
	Ratio	No. teeth	Ratio	No. teeth	Ratio	No. teeth	Ratio	No. teeth
1	3.507	$\frac{29}{18} \times \frac{37}{17}$			3.507	$\frac{28}{19} \times \frac{37}{17}$		
2	2.175	$\frac{29}{18} \times \frac{27}{20}$			1.989	$\frac{28}{19} \times \frac{27}{20}$		
3	1.418	$\frac{29}{18} \times \frac{22}{25}$			1.356	$\frac{28}{19} \times \frac{23}{25}$		
4	1.000				1.000			
5								
6								
reverse	3.927	$\frac{29}{18} \times \frac{39}{16}$			3.592	$\frac{28}{19} \times \frac{39}{16}$		

- 278. Overdrive, type
- 279. Forward gears on which overdrive can be selected
- 280. Overdrive ratio

FINAL DRIVE

- 290. Type of final drive **Hypoid gear**
- 291. Type of differential **Bevel gear**
- 292. Type of limited slip differential (if fitted)
- 293. Final drive ratio **3.727 or 4.100**
- Number of teeth **41/11 or 41/10**

Make **ISUZU**

Model **PR50SD**

F. I. A. Rec. No

IMPORTANT- The conformity of the car with the following items of the present recognition form is to be disregarded during the scrutineering, when the vehicle has been entered in group 2 (Touring cars) or 3 (Grand Touring cars) 41, 72, 80, 91, 142, 143, 144, 145, 146, 153, 156, 157, 160, 161, 162, 163, 164, 182, 184, 186, 187, 188, 189, 199, 201, 202, 203, 212, 213, 215, 216, 222, 225, 230, 250, 251, 252, 253, and photographs I, M, N, and page 8

During the scrutineering of cars entered in group 4 (Sportscars) only the following items of the present recognition form are to be taken into consideration: 1, 2, 3, 9, 20, 21, 22, 23, 24, 25, 26, 70, 71, 78, 79, 90, 130, 131, 132, 133, 134, 135, 136, 137, 138, 139, 140, 141, 147, 148, 149, 150, 158, 159, 170, 171, 172, 173, 185, 200, 270, 271, 274, 275, 290, 291, 292 and photographs A, B, D, E, F, G, H, J, K, and O.

Optional equipment affecting preceding information. This to be stated together with reference number.

Make ISUZU

Model PR50SD

F. I. A. Rec. No.

Photograph

B, 3/4 view of car from rear

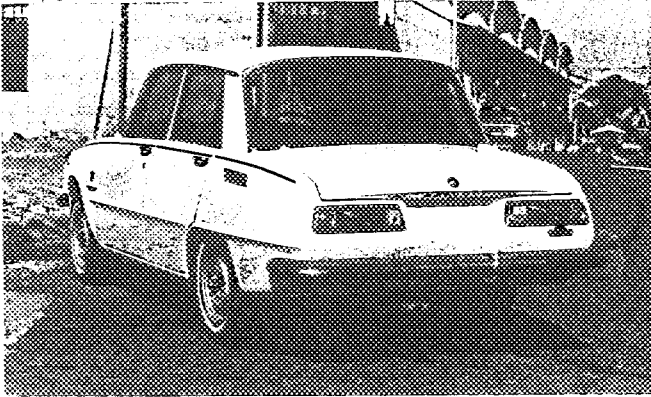

C, interior view of car through driver's door (open or removed) with dashboard

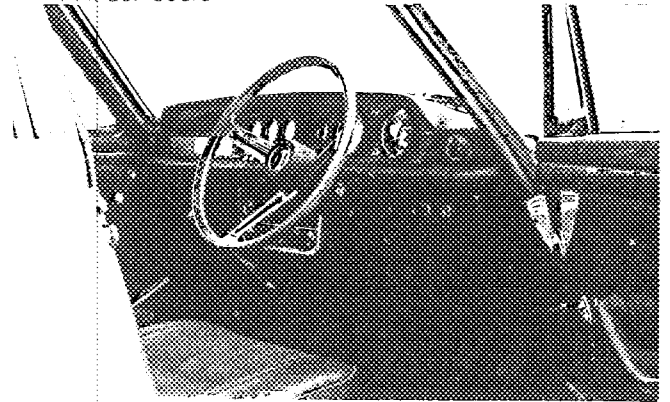

D, front axle complete, removed from car. Without wheels.

E, Rear axle complete without wheels, removed from car.

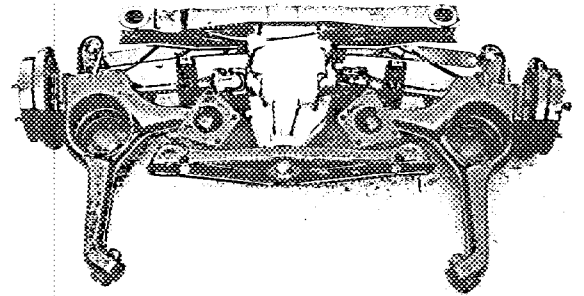
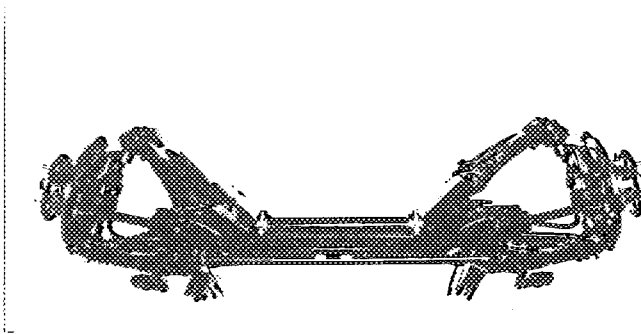

F, front brake, drum removed or disc with calipers

G, rear brake, drum removed or disc with calipers

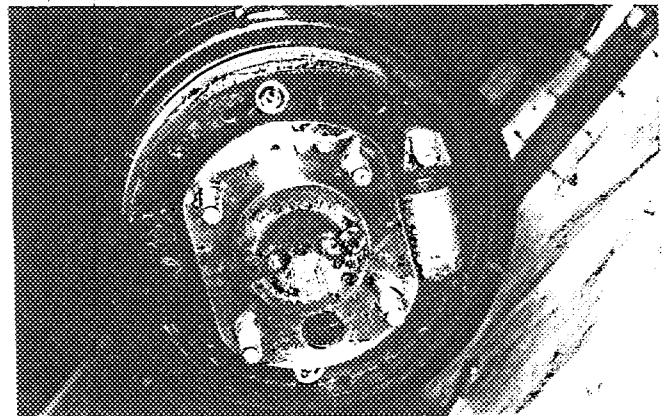
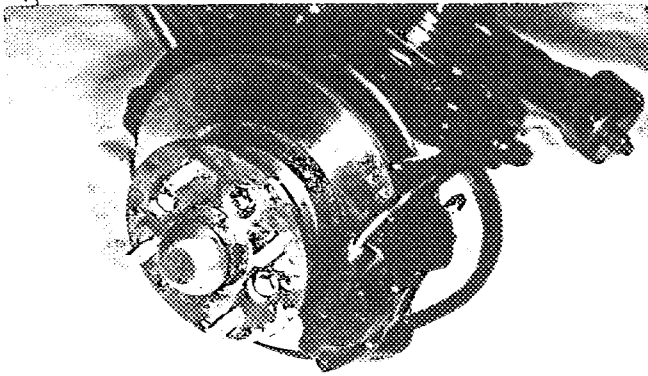

H, gear-box, view from side

I, silencer + exhaust pipes after exhaust manifold

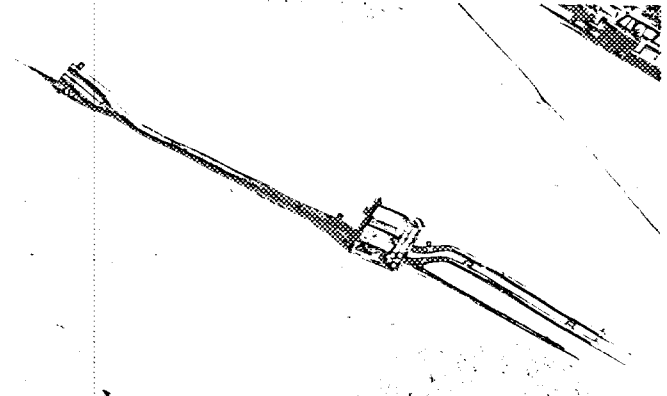
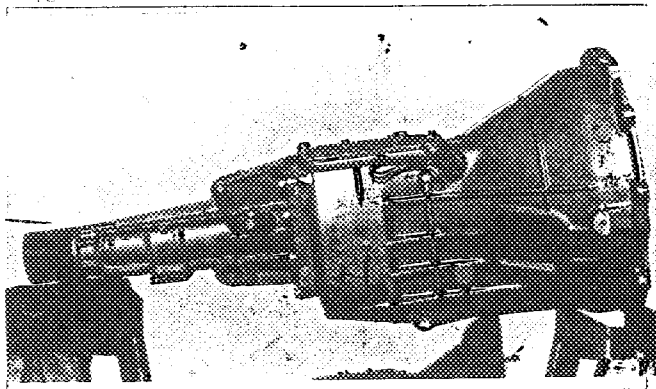

Make ISUZU

J, engine unit out of car, from right. With clutch and accessories but without air filter nor gear-box.

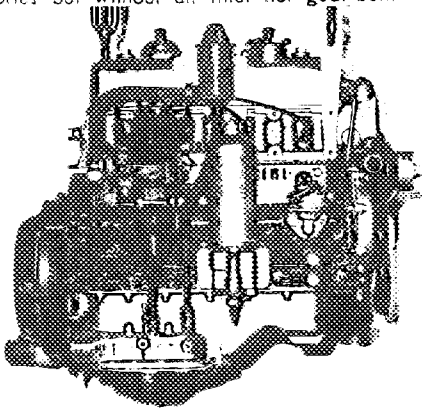

Model PR50SD

F.I.A. Rec. No

Photograph

K, engine unit out of car, from left. With clutch and accessories but without gear-box nor air filter.

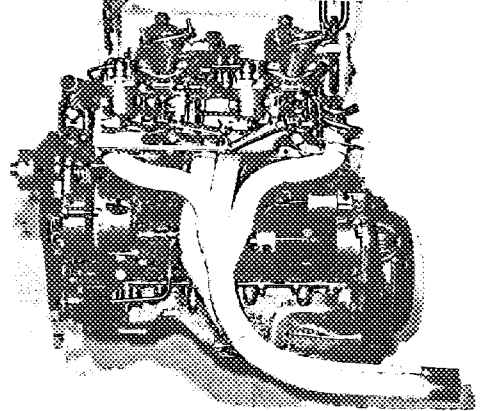

L, combustion chamber

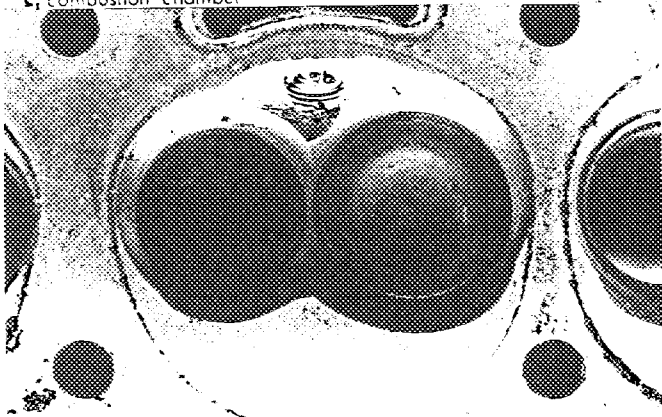

M, piston crown

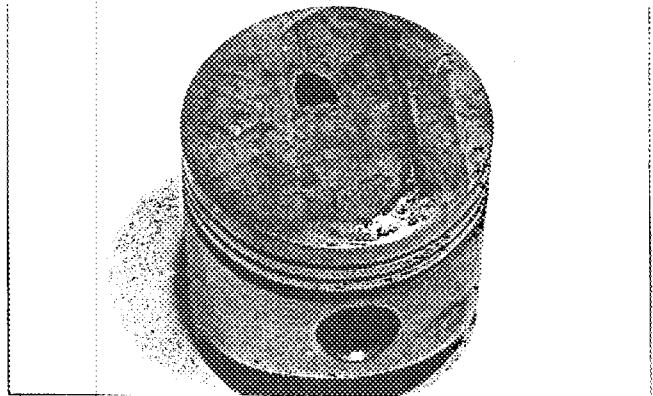

N, Carburettor (view from side of manifold)

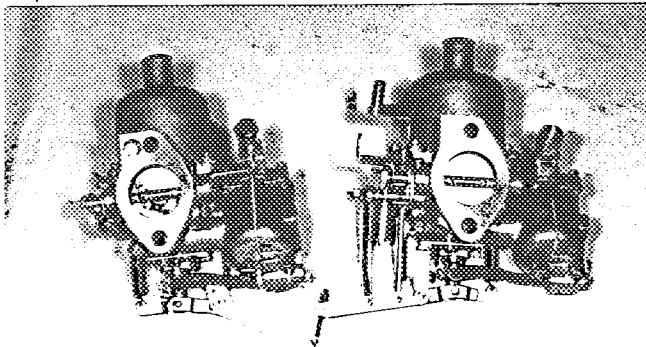

O, engine in car with all accessories, bonnet open or removed.

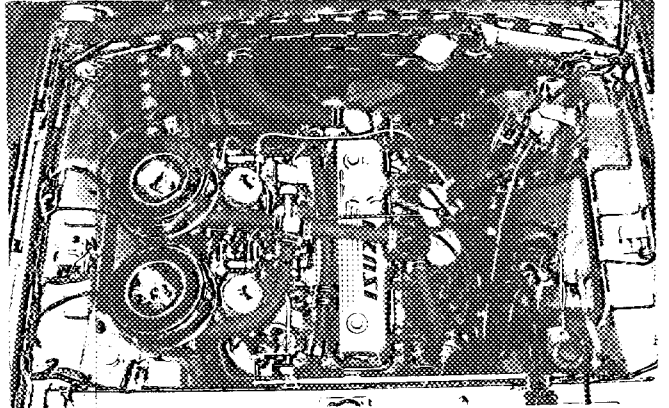

P, inlet manifold

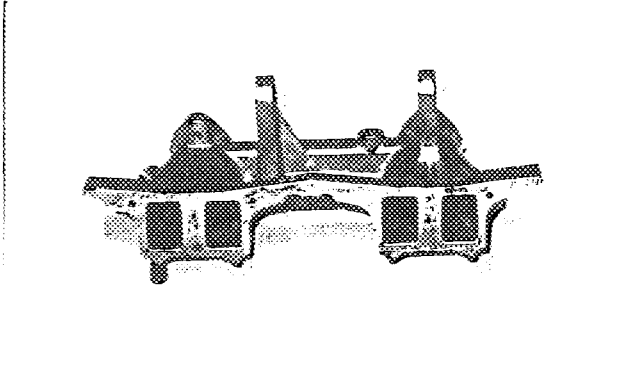

Q, exhaust manifold

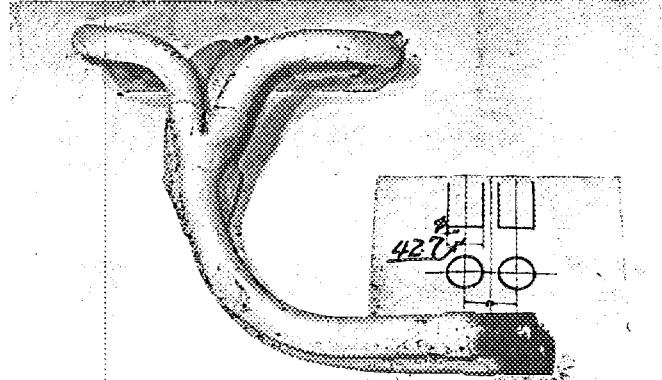

DIMENSIONS OF INTERIOR
(Conform to Art. 253 b of Appendix J)

For four seaters :

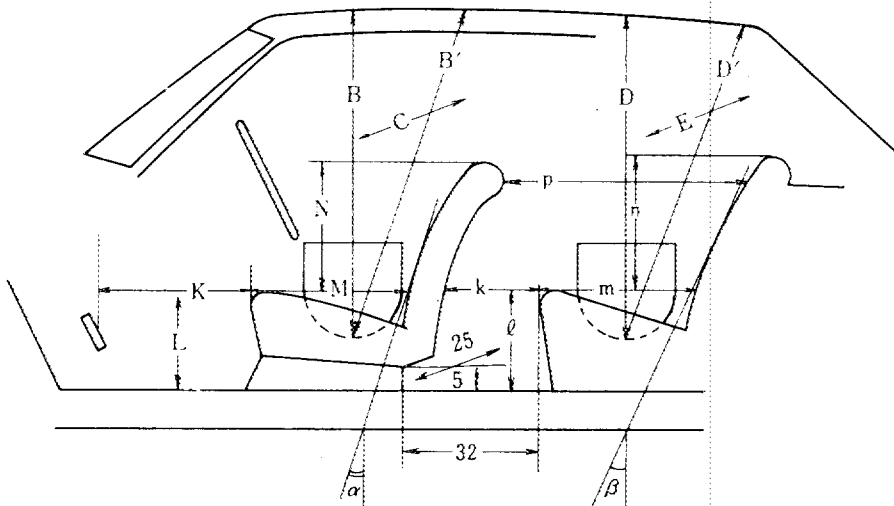

Minimum Dimensions (cm)							
B	B'	α	C	D	D'	β	E
94	97	15°	123	92	94	20°	122

Minimum Dimensions (cm)										
L	ℓ	M	m	N	n	k+m	p	k	k+l+m	K+L+M
29	30	46	44	40	39	70	73	26	100	121
0.9L = 26.1		0.85M = 39.1		0.8N = 32		0.8(k+m) = 56		(15)	(95)	(120)

Make ISUZU

Model PR50SD

F. I. A. Rec. No.

TWO STROKE ENGINES

- 300. System of cylinder scavenging
- 301. Type of lubrication
- 302. Inlet ports, length measured around cylinder wall mm inches
- 303. Height inlet port mm in. 304. Area mm² sq. in.
- 305. Exhaust ports, length measured around cylinder wall mm inches
- 306. Height exhaust port mm in. 307. Area mm² sq. in.
- 308. Transfer port, length measured around cylinder wall mm inches
- 309. Height transfer port mm in. 310. Area mm² sq. in.
- 311. Piston ports, length measured around piston mm inches
- 312. Height piston port mm in. 313. Area mm² sq. in.
- 314. Method of precompression 315. Precompression cyl.: yes /no
- 316. Bore mm inches 317. Stroke mm inches
- 318. Distance from top of cyl. block to highest point of exhaust port : mm inches
- 319. Distance from top of cyl. block to lowest point of inlet port : mm inches
- 320. Distance from top of cyl. block to highest point of transfer port : mm inches
- 321. Drawing of cylinder ports.

330. Supercharging—state full details hereafter :

JAPAN AUTOMOBILE FEDERATION

難波清治

Yasuharu Nanba