



FEDERATION INTERNATIONALE  
DU SPORT AUTOMOBILE

Homologation No

C2-0015

EC2-011-93  
1993年8月31日

FICHE D'HOMOLOGATION POUR MOTEUR DE VOITURE DE TOURISME (Classe II)  
HOMOLOGATION FORM FOR TOURING CAR ENGINE (Classe II)

Constructeur / Manufacturer: HONDA MOTOR CO., LTD      Modèle et type / Model and type: B18C ENGINE

Homologation valable à partir du / Homologation valid as from: 01 OCT. 1993

MOTEUR (version standard)  
ENGINE (standard version)

Cycle: 4-Stroke (OTTO)

Nombre et disposition des cylindres / Number and layout of the cylinders: 4-in line

Mode de refroidissement / Cooling system: Liquid

Cylindrée: Unitaire		Totale	
Cylinder capacity: Unitary	<u>449.5</u> cm <sup>3</sup>	Total	<u>1,798.0</u> cm <sup>3</sup>

Matériau du bloc cylindres / Cylinder block material: Aluminum-alloy

Vilebrequin:  
Crankshaft:

Matériau / Material: Steel

Type de paliers / Type of bearings: Plain

Bielles:  
Connecting rods:

Matériau / Material: Steel

Arbres à cames:  
Camshafts:

Nombre / Number: 2

Emplacement / Location: Top (DOHC)





Marque  
Make HONDA

Modèle  
Model B18C ENGINE

Homologation No

**C2-0015**

EC2-011-93

Culasse :  
Cylinder head :

Nombre  
Number 1

Système de commande des soupapes  
Type of valve operation Rocker arm

Angle entre axe de la soupape d'admission et axe de la soupape d'échappement  
Angle between inlet valve axle and exhaust valve axle 56°

Admission :            Nombre de soupapes par cylindre  
Inlet :                 Number of valves per cylinder 2

Echappement :        Nombre de soupapes par cylindre  
Exhaust :              Number of valves per cylinder 2

Système de refroidissement :    Mode de refroidissement  
Cooling system :                    Cooling type \_\_\_\_\_



### PHOTOS

Profil droit du moteur complet déposé  
Right hand view of complete dismantled engine

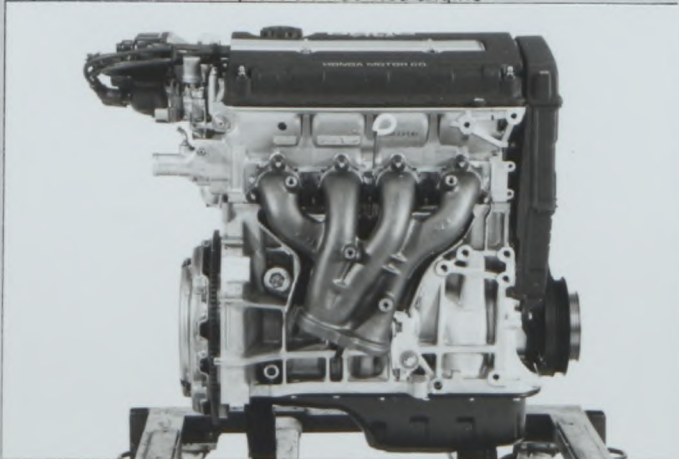

Profil gauche du moteur complet déposé  
Left hand view of complete dismantled engine

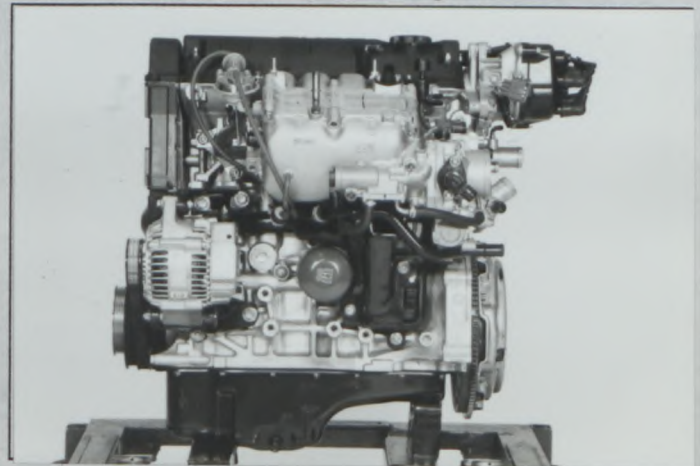

Culasse nue vue de dessus  
Bare cylinder head seen from above

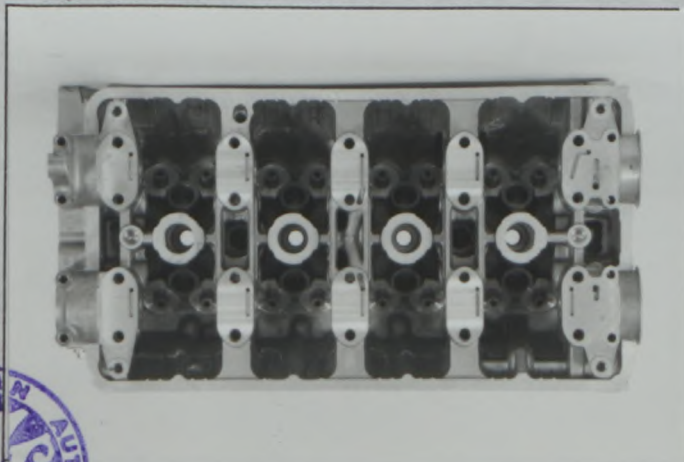

Culasse nue vue de dessous  
Bare cylinder head seen from below

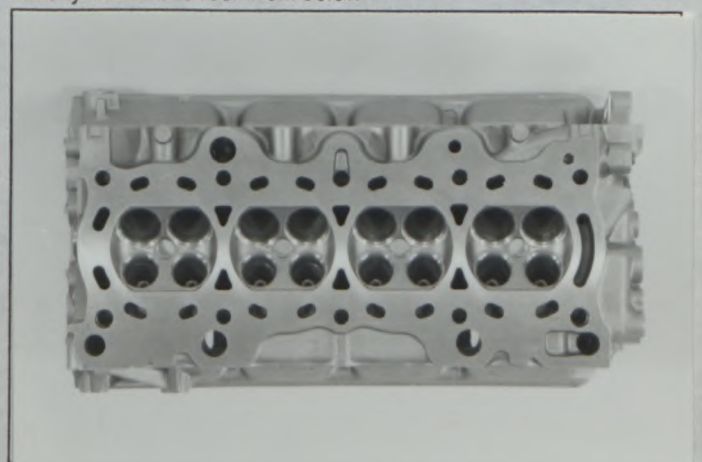



Marque  
Make

HONDA

Modèle  
Model

B18C ENGINE

Homologation No

C2-0015

EC2-011-93

Profil droit de culasse nue  
Right hand view of bare cylinder head

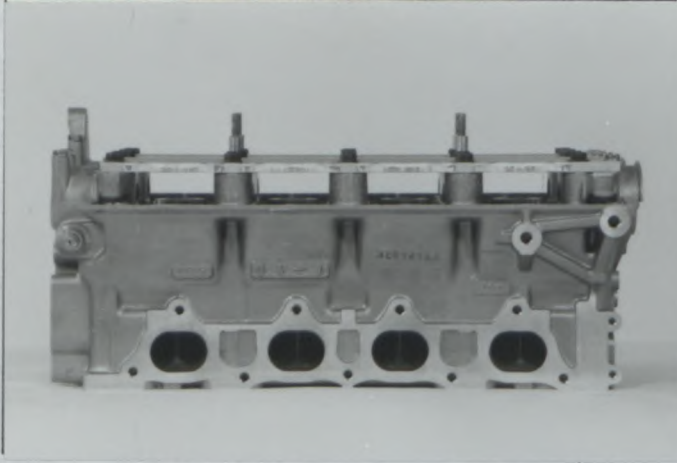

Profil gauche de culasse nue  
Left hand view of bare cylinder head

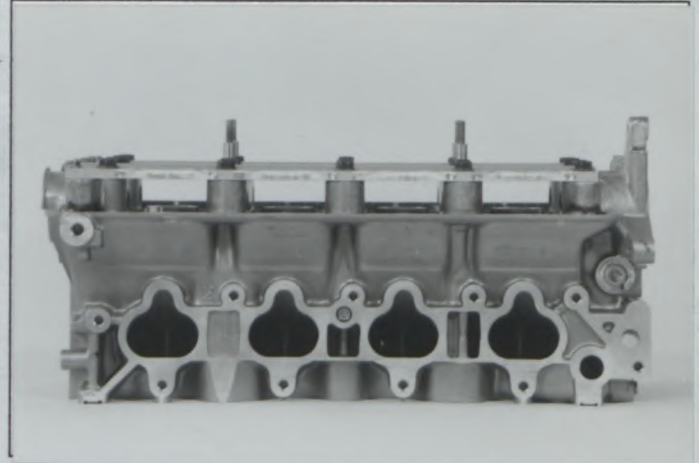

Bloc nu vu de dessus  
Bare block seen from above

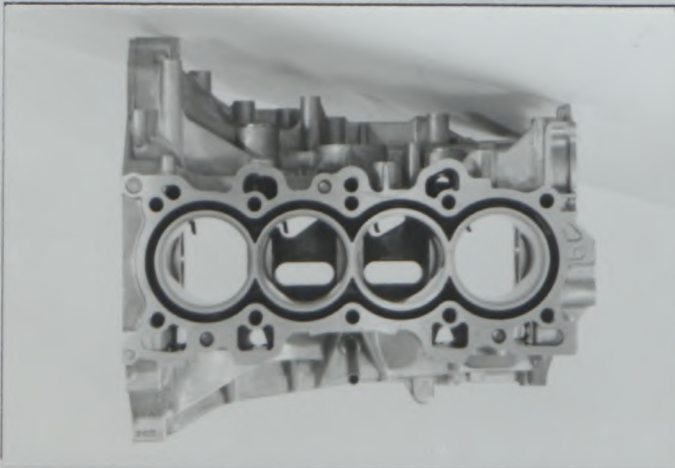

Bloc nu vu de dessous  
Bare block seen from below

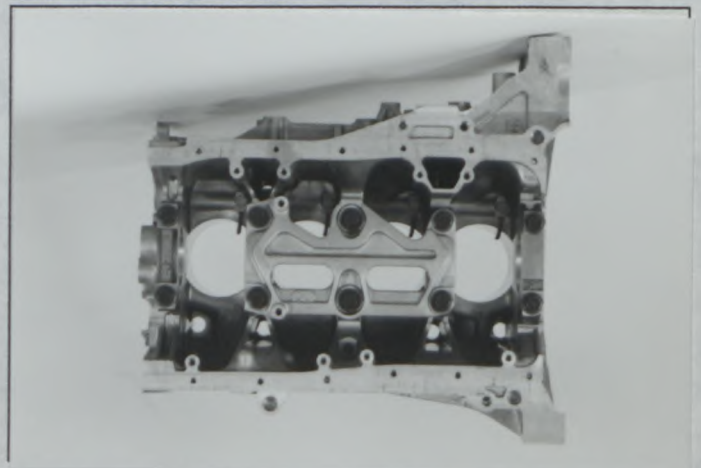

Profil droit du bloc nu  
Right hand view of bare block

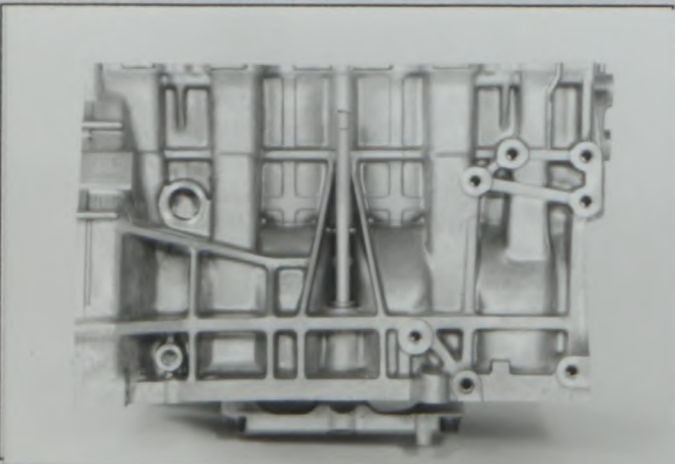

Profil gauche du bloc nu  
Left hand view of bare block

