

FEDERATION INTERNATIONALE DE L'AUTOMOBILE

Form of recognition in accordance with
 Appendix J to the International Sporting Code.

Manufacturer DAF
 Serial No of chassis .. 5502 ..
 Serial No of engine .. B110 ..
 Recognition is valid from .. 11 March 68 List .. 1968/4

Cylinder-capacity ... 1108 ... cm³ .. 67.61 .. 123
 Model 55
 Manufacturer DAF

The manufacturing of the model described in this recognition form was started on .. sept. .. 19 67 and the minimum production of .. 1000 .. identical cars, in accordance with the specifications of this form was reached on 13-12-67. 19 ..

Photograph A , 3/4 view of car from front

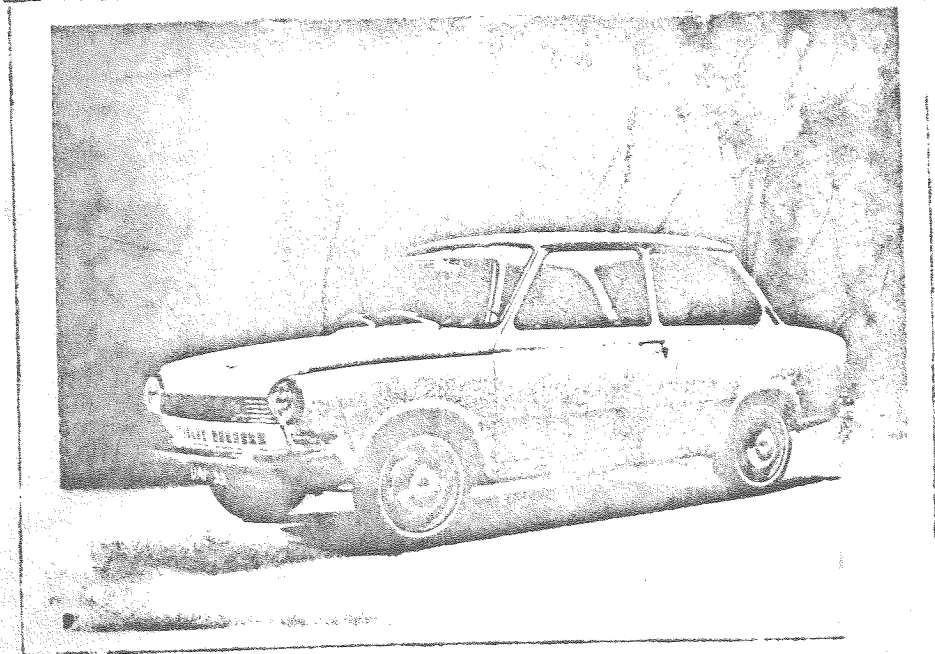

The vehicle described in this form has been subject to the following amendments :

Variants		Normal evolution of the type	
on 19 ..	rec.No List	on 19 ..	rec.No List
on 19 ..	rec.No List	on 19 ..	rec.No List
on 19 ..	rec.No List	on 19 ..	rec.No List
on 19 ..	rec.No List	on 19 ..	rec.No List
on 19 ..	rec.No List	on 19 ..	rec.No List

Stamp and signature of the
 National Sporting Authority

Stamp and signature of the F.I.A.

Substphor

Page

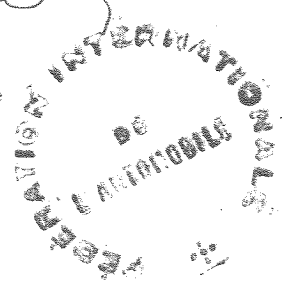

Photograph B, 3/4 view of the car from rear

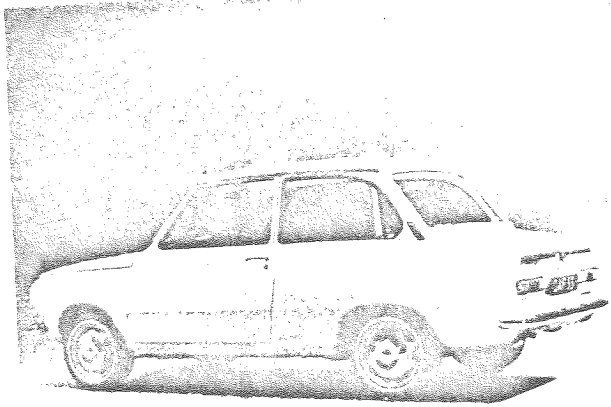

Photograph C, interior view of car through driver's door (open or made view)

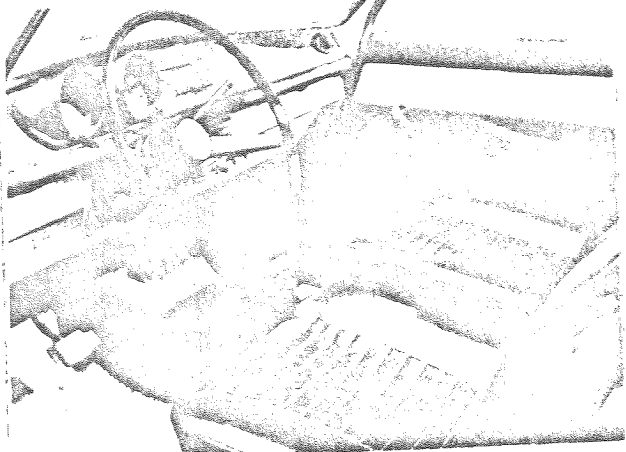

Photograph D, front axle complete, without wheels, removed from the car

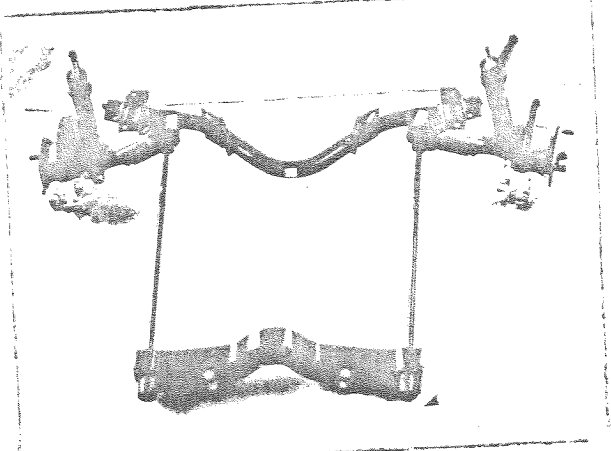

Photograph E, rear axle complete, without wheels, removed from the car.

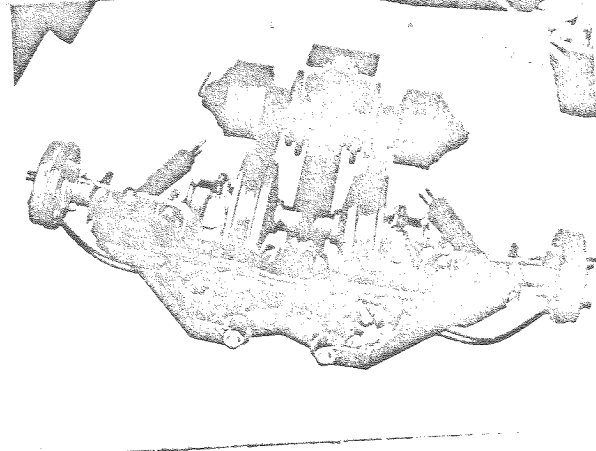

Photograph F, front brake, drum removed.

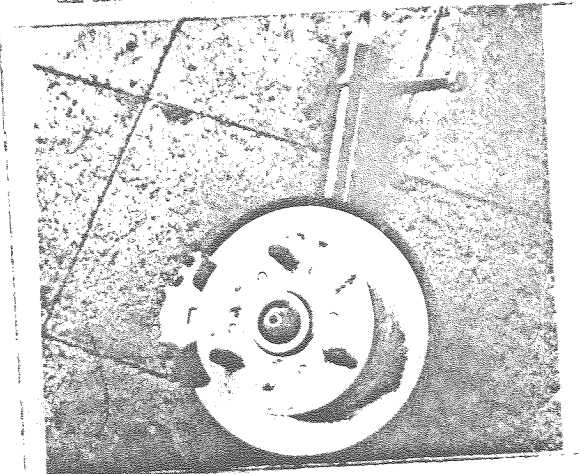

Photograph G, rear brake, drum removed.

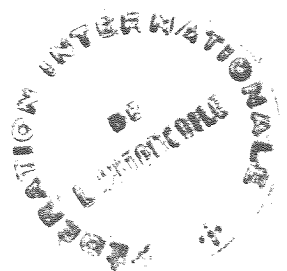

Photograph H

gear-box , view from side.

See photograph E

Photograph I



Photograph J

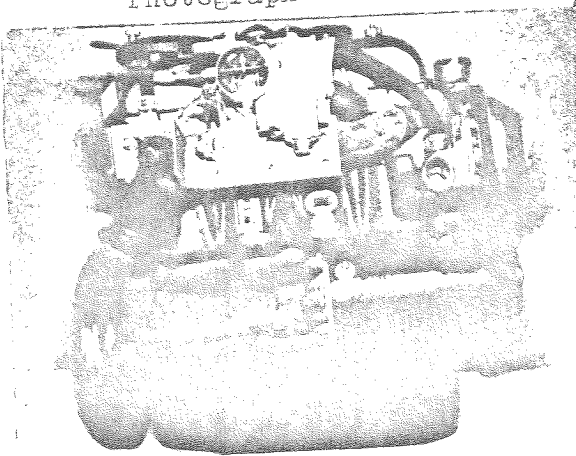

Photograph K

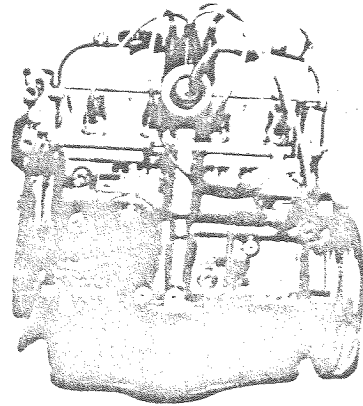

Photograph L

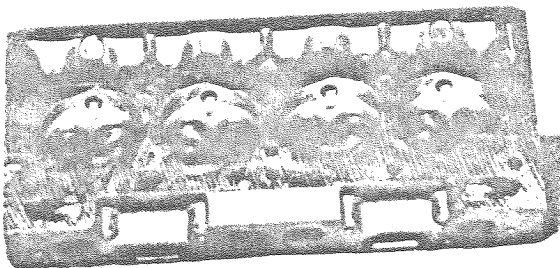

Photograph M

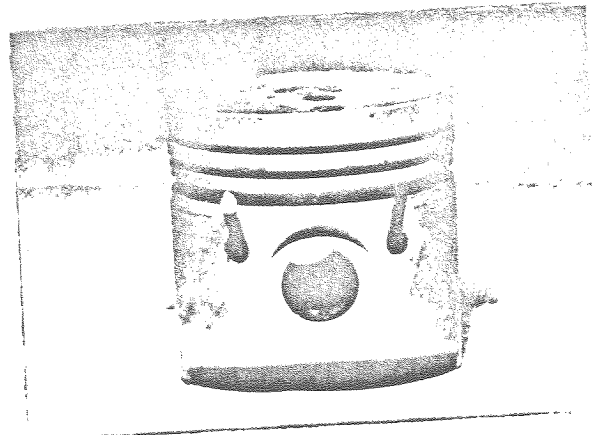

Photograph N

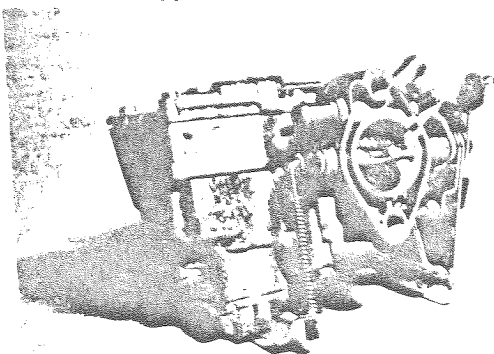

Photograph O

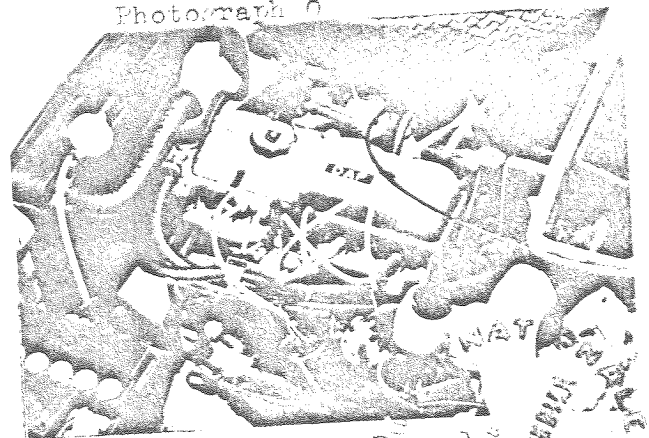

REPRODUCTION OF THIS DOCUMENT IS PROHIBITED

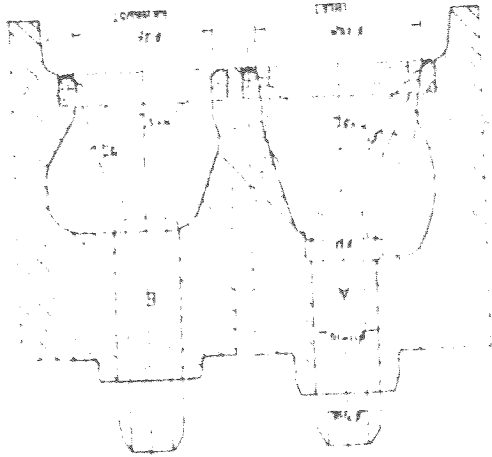

Drawing exhaust and inlet ports of cylinder-head. Indicate scale or dimensions.

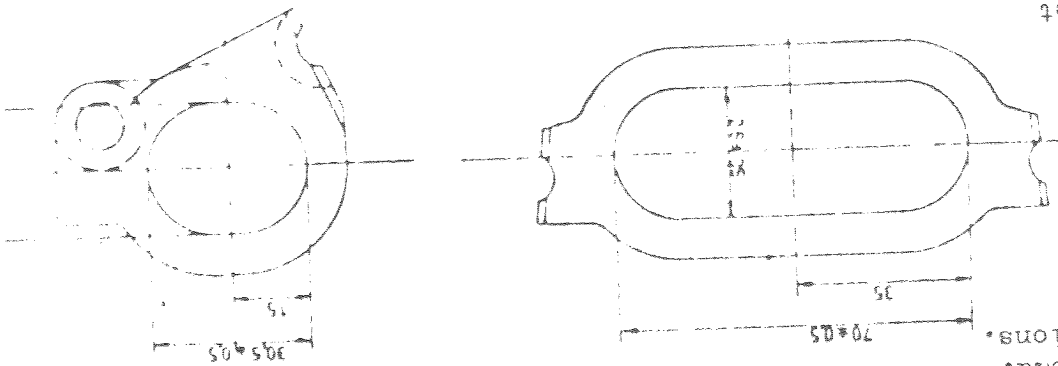

Drawing exhaust manifold ports, side of cylinder-head. Indicate scale or dimensions.

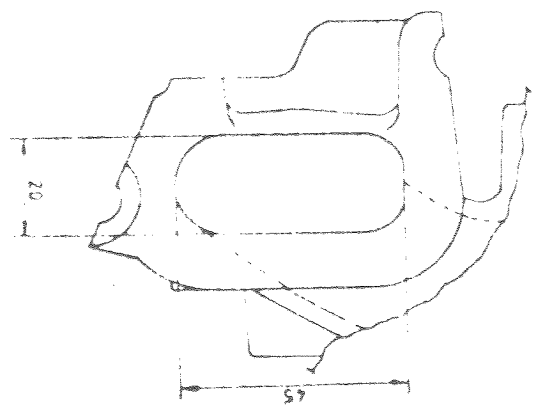

Drawing inlet manifold ports, side of cylinder-head. Indicate scale or dimensions.



Photograph 2

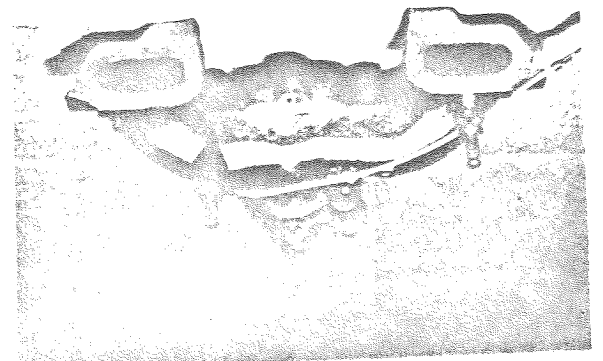

Photograph 1

Make

DAF

Model

55

Year

IMPORTANT - the underlined items must be stated in two measuring systems, one of which must be the metric system. See conversion table hereafter.

CAPACITIES AND DIMENSIONS

1. <u>Wheelbase</u>	2250	mm	88.58	inches
2. <u>Front track</u> (with standard tyres fitted)	1280	mm	50.39	inches
3. <u>Rear track</u> (with standard tyres fitted)	1250	mm	49.21	inches
4. Overall length of the car	398	cm	152.76	inches
5. Overall width of the car	154	cm	60.62	inches
6. Overall height of the car	138	cm	54.33	inches
7. <u>Capacity of fuel tank</u> (reserve included)			38	litre
	10	Gallon US	8.4	Gallon Imp.
8. Seating capacity	4-5	pers.		
9. <u>Weight</u> , total weight of the car with normal equipment, water, oil and spare wheel but without fuel nor repair tools :				
	740	kg	1632	lbs

*) Difference hereafter Difference widths must

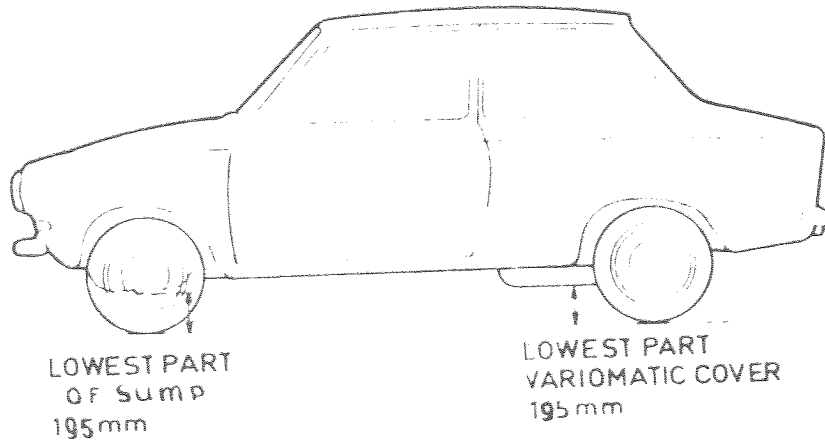

mentioned different rim wheels concerned.

CONVERSION TABLE

1 inch/pouce	- 2.54	cm	1 quart US	- 0.94635	litre
1 foot/pied	- 30.4799	cm	1 pint (pt)	- 0.47317	litre
1 square inch/pouce carré	- 6.4516	cm ²	1 gallon Imp.	- 4.54609	litre
1 cubic inch/pouce cube	- 16.3871	cm ³	1 gallon US	- 3.78541	litre
1 pound/livre (lb)	- 453.592	gr.	1 hundred weight (cwt)	- 907.185	kg

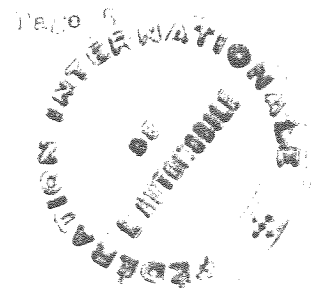

CHASSIS AND COACHWORK (Photographs A, B and C)

20. Chassis/body construction : ~~separata~~ / unitary construction.
21. Unitary construction, material(s) sheet steel
Separate construction
22. Material(s) of chassis
23. Material(s) of coachwork
24. Number of doors 2 Material(s) sheet steel
25. Material(s) of bonnet steel
26. Material(s) of boot lid steel
27. Material(s) of rear-window glass securit
28. Material(s) of windscreen glass securit BS-1
29. Material(s) of front-door windows glass securit
30. Material(s) of rear-door windows
31. Sliding system of door windows winding
32. Material(s) of rear-quarter light glass securit

ACCESSORIES AND UPHOLSTERY

38. Interior heating : yes - ~~xx~~ 39. Air-conditioning : yes - ~~xx~~
40. Ventilation : yes - ~~xx~~
41. Front seats, type of upholstery P.V.C. upholstered bucket type seats
42. Weight of front seat(s), complete with supports and rails, out of the car :
12,5 kg 27.5 lbs
43. Rear seats, type of upholstery P.V.C.
44. Front bumper, material(s) stainless steel Weight 3,3 kg 7.3 lbs
45. Rear bumper, material(s) stainless steel Weight 3,2 kg 7.06 lbs

WHEELS

50. Type pressed steel disc (flat hump)
51. Weight (per wheel, without tyre) 5,4 kg 11.9 lbs
52. Method of attachment 3 nuts
53. Rim diameter 354,8 mm 13.97 inches
54. Rim width 101,5 mm 4 inches Alt. 4.5" *
55. Standard tyre size fitted, front 135SR14 rear 135SR14
135-14X/5.65-14X 135-14X/5.65-14X
145-14 145-14

STEERING

60. Type Rack and Pinion
61. Servo-assistance : ~~xxx~~ - no
62. Number of turns of steering wheel from lock to lock 3,25
63. In case of servo-assistance

* offset increases track by $\frac{1}{2}$ "

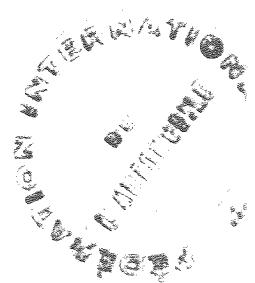

SUSPENSION

- 70. Front suspension (photogr. D), type Independent, longitudinal torsion bars
- 71. Type of spring torsion
- 72. Stabiliser (if fitted) yes
- 73. No of shock absorbers 2 74. Type telescopic double-acting hydraulic
- 78. Rear suspension (photogr. E), type Independent swing axles
- 79. Type of spring coil
- 80. Stabiliser (if fitted) no
- 81. No of shock absorbers 2 82. Type telescopic double-acting hydraulic

BRAKES (photographs F and G)

- 90. Method of operation hydraulic
- 91. Servo-assistance : ~~yes~~ - no 92. Type --
- 93. No of hydraulic master cylinders 1

	Front		Rear	
94. Number of cylinders per wheel	1		1	
95. Bore of wheel cylinder(s)	mm	in.	17,46 mm	0.687 in.
Drum brakes				
96. Inside diameter	mm	in.	200 mm	7.87 in.
97. Length of brake linings	mm	in.	196 mm	7.72 in.
98. Width of brake linings	mm	in.	40 mm	1.57 in.
99. No of shoes per brake			2	
100. Total area per brake	mm ²	in ²	157 mm ²	24.34 in ²
Disc brakes				
101. Outside diameter	248 mm	9.75 in.	mm	in.
102. Length of brake linings	55 mm	2.17 in.	mm	in.
103. Width of brake linings	37 mm	1.46 in.	mm	in.
104. No of pads per brake	2			
105. Total area per brake	2x2000 mm ²	6.2 in ²	mm ²	in ²

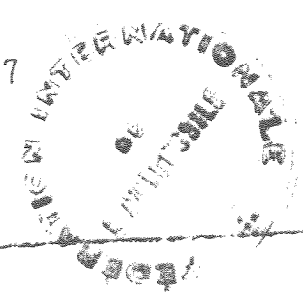

ENGINE (photographs J and K)

130. Cycle	4	131. No of cylinders	4
132. Cylinder arrangement	in line		
133. Bore	70 mm 2.756 in.	134. Stroke	72 mm 2.835 in.
135. Capacity per cylinder	277 cm ³		16.9 cu. in.
136. Total cylinder-capacity	1108 cm ³		67.61 cu. in.
137. Material(s) of cylinder-block	cast iron		
138. Material(s) of sleeves (if fitted)	steel		
139. Cylinder-head, material(s)	aluminium	140. Number of inlet ports	4
		141. Number of exhaust ports	4
142. Compression ratio	8,5:1		
143. Volume of one combustion chamber	31,17 cm ³		1.963 cu. in.
144. Piston, material(s)	aluminium	145. No of rings	3
146. Distance from gudgeon pin centre line to highest point of piston crown :			
	40 mm		1.57 inches
147. Crankshaft :	moulded / stamped	148. Type of crankshaft	4 throw
149. Number of crankshaft main bearings	5		
150. System of lubrication :	dry sump / oil in sump		
151. Capacity, lubricant	2,5 ltrs	4.40 pints	2.64 quarts
152. Oil cooler :	yes / no	153. Method of engine cooling	water
154. Capacity of cooling system	4,8 ltrs	8.45 pints	5.07 quarts
155. Cooling fan (if fitted), dia.	28 cm		11.02 inches
156. Number of blades of cooling fan	6		
Bearings			
157. Crankshaft main, type plain		Dia.	46 mm 1.811 in.
158. Connecting rod big end, type plain		Dia.	43,98mm 1.731 in.
Weights			
159. Flywheel (clean)	7,83 ± 0,01 kg		lbs
160. Flywheel with clutch (all turning parts)	12,796 kg		lbs
161. Crankshaft	8,2 ± 0,2 kg	162. Connecting rod	0,46 ± 0,03 kg
			lbs
163. Piston with rings and pin	0,36 ± 0,01 kg		lbs

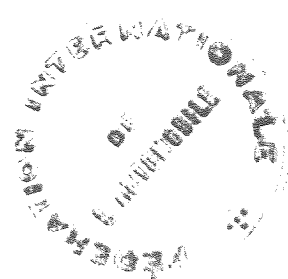

FOUR STROKE ENGINES

- 170. No of camshafts 1
- 171. Location LH side engineblock
- 172. Type of camshaft drive chain driven
- 173. Type of valve operation push-rod

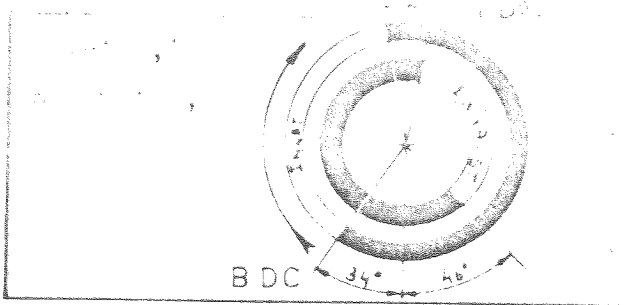

INLET (see page 4)*

- 180. Material(s) of inlet manifold aluminium
 - 181. Diameter of valves 31 mm 1.22 inches
 - 182. Max. valve lift 7,15 mm 0.281 inches
 - 183. No of valve springs 1
 - 184. Type of spring coil
 - 185. No of valves per cylinder 1
 - 186. Tappet clearance for checking timing (cold) 0,15 mm .0059 inches
 - 187. Valves open at (with tolerance for tappet clearance indicated)
 - 188. Valves close at (with tolerance for tappet clearance indicated)
 - 189. Degrees of crankshaft rotation from zero to -
 - maximum valve lift 3/4 maximum valve lift
- } see diagram

190. Air filter, type dry

EXHAUST (see page 4)

- 195. Material(s) of exhaust manifold cast iron
 - 196. Diameter of valves 26,8 mm 1.06 inches
 - 197. Max. valve lift 7,09 mm 0.280 inches
 - 198. No of valve springs 1
 - 199. Type of spring coil
 - 200. No of valves per cylinder 1
 - 201. Tappet clearance for checking timing (cold) 0,20 mm .0079 inches
 - 202. Valves open at (with tolerance for tappet clearance indicated)
 - 203. Valves close at (with tolerance for tappet clearance indicated)
 - 204. Degrees of crankshaft rotation from zero to -
 - maximum valve lift 3/4 maximum valve lift
- } see diagram

CARBURETION (photograph N)

- 210. No of carburettors fitted 1
- 211. Type horizontal
- 212. Make Solex
- 213. Model 32 EHSA
- 214. Flange hole diameter of exit port(s) of carburettor 32 mm 1.26 in.
- 215. Minimum diameter of air-passage 26 mm 1.02 in.

FUEL INJECTION (if fitted)

- 220. Make of pump
- 221. No of plungers
- 222. Model or type of pump
- 223. Total no of injectors
- 224. Location of injectors

* For additional information concerning two-stroke engines and super-charged engines see page 13.

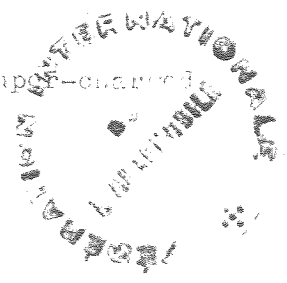

ENGINE ACCESSORIES

230. Fuel pump : mechanical ~~and electrical~~ 231. No fitted 1
 232. Type of ignition system coil 233. No of distributors 1
 234. No of ignition coils 1 235. No of spark plugs per cylinder 1
 236. Generator, number fitted 1 237. Method of drive belt
 238. Voltage of generator 12 volts 239. Battery, number 1
 240. Location under bonnet
 241. Voltage of battery 12 volts

ENGINE AND CAR PERFORMANCE (as declared by manufacturer in catalogue)

250. Max. engine output 45 (type of horsepower: DIN) at 5000 rpm.
 251. Maximum rpm 5500 output at that figure
 252. Maximum torque 8,0 mkg at 2800 rpm.
 253. Maximum speed of the car 136 km/hour 85 miles/hour

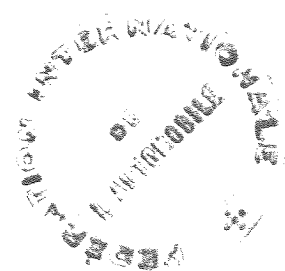

IVE TRAIN

CLUTCH

- 261. Type of clutch centrifugal 261. No of ~~plates~~ shoes 8
- 262. Dia. of clutch plates cm inches
- 263. Dia. of linings, inside cm in. outside cm in.
- 264. Method of operating clutch automatic

GEAR BOX (photograph H)

- 270. Manual type, make type
- 271. No of gear-box ratios forward 272. Synchronized forward ratios
- 273. Location of gear-shift
- 274. Automatic, make DAF type VARIOMATIC
- 275. No of forward ratios 276. Location of gear-shift on tunnel

277.	Manual		Automatic		Alternative manual/automatic			
	Ratio	No teeth	Ratio	No teeth	Ratio	No teeth	Ratio	No teeth
1			infinite					
2			variable					
3			between					
4			14.87:1					
5			and					
6			3.73:1					
			(final drive					
			included)					
reverse								

- 278. Overdrive, type
- 279. Forward gears on which overdrive can be selected
- 280. Overdrive ratio

FINAL DRIVE

- 290. Type of final drive integral part of complete VARIOMATIC transmission
- 291. Type of differential
- 292. Type of limited slip differential (if fitted)
- 293. Final drive ratio
- Number of teeth

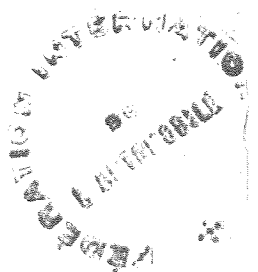

Optional equipment affecting peculiar information

- sump guard
- additional fuel tank 20 L.
- Triplex glass windscreen
- Alternator

