



# JAPAN AUTOMOBILE FEDERATION

F. I. A. Recognition No. 1536  
Group 2 - Touring

## FEDERATION INTERNATIONALE DE L'AUTOMOBILE

Form of recognition in accordance with  
Appendix J to the International Sporting Code.

Manufacturer Mitsubishi Heavy Industries, Ltd. Cylinder-capacity 1088 cm<sup>3</sup> 66.39 cu. in.  
 Serial No. of chassis A82-000001 Model Mitsubishi A82 (Colt) Manufacturer Mitsubishi Heavy Industries, Ltd.  
 Serial No. of engine KE44-176540 Manufacturer Ltd. " "  
 Recognition is valid from 1st November 1968 List 1968/10  
 The manufacturing of the model described in this recognition form was started on Sept. 1967 and the minimum production of 1000 identical cars, in accordance with the specifications of this form was reached on Mar. 1968

Photograph A, 3/4 view of car from front

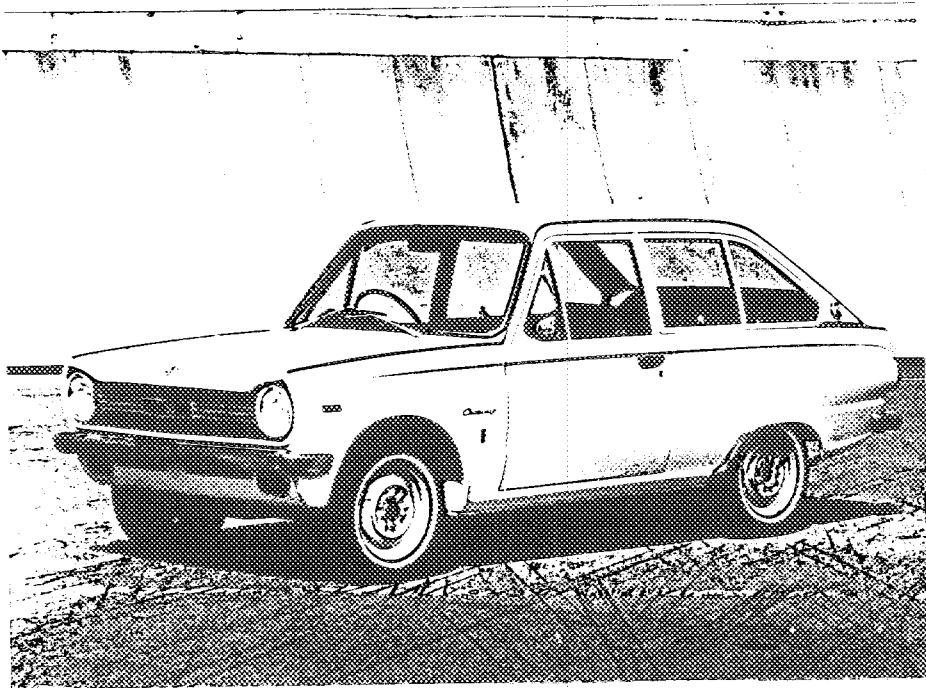

The vehicle described in this form has been subject to the following amendments

| Variants |    |          |      | Normal evolution of the type |    |          |      |
|----------|----|----------|------|------------------------------|----|----------|------|
| on       | 19 | rec. No. | List | on                           | 19 | rec. No. | List |
| on       | 19 | rec. No. | List | on                           | 19 | rec. No. | List |
| on       | 19 | rec. No. | List | on                           | 19 | rec. No. | List |
| on       | 19 | rec. No. | List | on                           | 19 | rec. No. | List |
| on       | 19 | rec. No. | List | on                           | 19 | rec. No. | List |

Stamp and signature of the  
National Sporting Authority

Stamp and signature of the F. I. A.

Make **Mitsubishi**

Model **A82**

F. I. A. Rec. No.

**IMPORTANT** - the underlined items must be stated in two measuring systems, one of which must be the metric system. See conversion table hereafter.

**CAPACITIES AND DIMENSIONS**

|   |      |           |       |             |
|---|------|-----------|-------|-------------|
| 1. <u>Wheelbase</u>   | 2200 | mm        | 86.61 | inches      |
| 2. <u>Front track</u>   | 1220 | mm        | 48.03 | inches *    |
| 3. <u>Rear track</u>  | 1185 | mm        | 46.65 | inches *    |
| 4. Overall length of the car  |      | 366.0     | cm    | inches      |
| 5. Overall width of the car   |      | 145.0     | cm    | inches      |
| 6. Overall height of the car  |      | 140.0     | cm    | inches      |
| 7. <u>Capacity of fuel tank</u> (reserve included)  |      |           |       | 40 ltrs     |
|   | 10.6 | Gallon US |       | Gallon Imp. |
| 8. Seating capacity   | 5    |           |       |             |
| 9. <u>Weight</u> , total weight of the car with normal equipment, water, oil and spare wheel but without fuel nor repair tools: |      |           |       |             |
|   | 700  | kg        | 1543  | lbs cwt     |

\* Differences in track caused by the use of other wheels with different rim widths must be stated when recognition is requested for the wheels concerned.

Specify ground clearance in relation to the track and give drawing of two fixed points of the vehicle's structure at which measurements are taken.

These ground clearance dimensions are only for information when checking the track and can in no way affect the eligibility of the car.

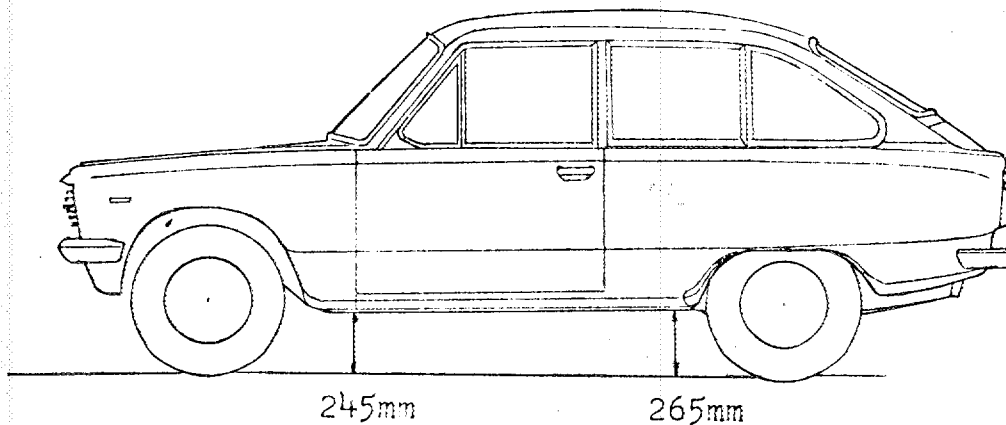

**CONVERSION TABLE**

|                             |    |                        |                        |    |             |
|-----------------------------|----|------------------------|------------------------|----|-------------|
| 1 inch / pouce              | -- | 2.54 cm                | 1 quart US             | -- | 0.9464 ltrs |
| 1 foot / pied               | -- | 30.4794 cm             | 1 pint (pl)            | -- | 0.566 ltrs  |
| 1 square inch / pouce carré | -- | 6.452 cm <sup>2</sup>  | 1 gallon Imp.          | -- | 4.546 ltrs  |
| 1 cubic inch / pouce cube   | -- | 16.387 cm <sup>3</sup> | 1 gallon US            | -- | 3.785 ltrs  |
| 1 pound / livre (lb)        | -- | 453.593 gr.            | 1 hundred weight (cwt) | -- | 50.802 kg   |

**CHASSIS AND COACHWORK** (Photographs A, B and C)

- 20. Chassis/body construction : ~~separate~~ / unitary construction
- 21. Unitary construction, material (s) **Steel**  
Separate construction
- 22. Separate Constructions: Material(s) of chassis
- 23. Material (s) of coachwork
- 24. Number of doors **2** Material (s) **Steel**
- 25. Material (s) of bonnet **Steel**
- 26. Material (s) of boot lid **Steel**
- 27. Material (s) of rear-window **Glass**
- 28. Material (s) of windscreen **Glass**
- 29. Material (s) of front-door windows **Glass**
- 30. Material (s) of rear-door windows **-**
- 31. Sliding system of door windows **Vertical, Manual**
- 32. Material (s) of rear-quarter light **Glass**

**ACCESSORIES AND UPHOLSTERY**

- 38. Interior heating : ~~yes~~ - no
- 39. Air-conditioning : ~~yes~~ - no
- 40. Ventilation : yes - ~~yes~~
- 41. Front seats, type of seats and upholstery **Separate, Vinyl Leather**
- 42. Weight of front seat (s), complete with supports and rails, out of the car :  
**10.7 x 2** kg lbs
- 43. Rear seats, type of seats and upholstery **Bench, Vinyl Leather**
- 44. Front bumper, material (s) **Steel** Weight **4.7** kg lbs
- 45. Rear bumper, material (s) **Steel** Weight **3.1** kg lbs

**WHEELS**

- 50. Type **Pressd Steel**
- 51. Weight (per wheel, without tyre) **4.8** kg lbs
- 52. Method of attachment **Wheel nut (5 nuts)**
- 53. Rim diameter **329** mm **13.0** inches
- 54. Rim width **89** mm **3.5** inches

**STEERING**

- 60. Type **Ball nut**
- 61. Servo-assistance : ~~yes~~ - no
- 62. Number of turns of steering wheel from lock to lock **2.6**
- 63. In case of servo-assistance

**SUSPENSION**

- 70. Front suspension (photogr. D), type Independent, Wishbone
- 71. Type of spring Transverse Leaf
- 72. Stabiliser (if fitted) \_\_\_\_\_
- 73. Number of shockabsorbers 2 74. Type Hydraulic Telescopic
- 78. Rear suspension (photogr. E), type Rigid
- 79. Type of spring Semi-elliptic Leaf
- 80. Stabiliser (if fitted) \_\_\_\_\_
- 81. Number of shockabsorbers 2 82. Type Hydraulic Telescopic

**BRAKES (photographs F and G)**

- 90. System Hydraulic
- 91. Servo-assistance (if fitted), type \_\_\_\_\_
- 92. Number of hydraulic master cylinders 1

|                                   | FRONT                  |         | REAR                   |         |
|-----------------------------------|------------------------|---------|------------------------|---------|
| 93. Number of cylinders per wheel | 2                      |         | 1                      |         |
| 94. Bore of wheel cylinder (s)    | 22.2 mm                | in.     | 19.1 mm                | in.     |
| <b>Drum brakes</b>                |                        |         |                        |         |
| 95. Inside diameter               | 203.0 mm               | in.     | 203.0mm                | in.     |
| 96. Length of brake linings       | 221.0 mm               | in.     | 221.0mm                | in.     |
| 97. Width of brake linings        | 35.0 mm                | in.     | 35.0 mm                | in.     |
| 98. Number of shoes per brake     | 2                      |         | 2                      |         |
| 99. Total area per brake          | 15,500 mm <sup>2</sup> | sq. in. | 15,500 mm <sup>2</sup> | sq. in. |
| <b>Disc brakes</b>                |                        |         |                        |         |
| 100. Outside diameter             | mm                     | in.     | mm                     | in.     |
| 101. Thickness of disc            | mm                     | in.     | mm                     | in.     |
| 102. Length of brake linings      | mm                     | in.     | mm                     | in.     |
| 103. Width of brake linings       | mm                     | in.     | mm                     | in.     |
| 104. Number of pads per brake     |                        |         |                        |         |
| 105. Total area per brake         | mm <sup>2</sup>        | sq. in. | mm <sup>2</sup>        | sq. in. |

Make Mitsubishi

Model A82

F.I.A. Rec. No.

ENGINE (photographs J and K)

- 130. Cycle 4
- 131. Number of cylinders 4
- 132. Cylinder arrangement In-Line
- 133. Bore 73 mm 2.87 in. 134. Stroke 65 mm 2.56 in.
- 135. Capacity per cylinder 272 cm<sup>3</sup> 16.60 cu. in.
- 136. Total cylinder-capacity 1,088 cm<sup>3</sup> 66.39 cu. in.
- 137. Material (s) of cylinder block Cast-Iron
- 138. Material (s) of sleeves (if fitted) \_\_\_\_\_
- 139. Cylinder-head, material (s) Aluminium Alloy Number fitted 1
- 140. Number of inlet ports 4
- 141. Number of exhaust ports 4
- 142. Compression ratio 8.5
- 143. Volume of one combustion chamber 36.3 cm<sup>3</sup> cu. in.
- 144. Piston, material Aluminium Alloy
- 145. Number of rings 3
- 146. Distance from gudgeon pin centre line to highest point of piston crown 35.5 mm inches
- 147. Crankshaft : ~~machined~~ / stamped
- 148. Type of crankshaft : integral / ~~XXXXXX~~
- 149. Number of crankshaft main bearings 3
- 150. Material of bearing cap Cast-Iron
- 151. System of lubrication : ~~dry sump~~ / oil in sump
- 152. Capacity, lubricant 3 ltrs pts quarts US
- 153. Oil cooler : ~~yes~~ / no
- 154. Method of engine cooling Water pints quarts US
- 155. Capacity of cooling system 4.3 ltrs inches
- 156. Cooling fan (if fitted), dia. 30 cm
- 157. Number of blades of cooling fan 4

Bearings

- 158. Crankshaft main, type Plain Dia. 64 mm in.
- 159. Connecting rod big end, Plain Dia. 52 mm in.

Weights

- 160. Flywheel (clean) 6.8 kg lbs
- 161. Flywheel with clutch (all turning parts) 10.6 kg lbs
- 162. Crankshaft 10.0 kg lbs
- 163. Connecting rod 0.52 kg lbs
- 164. Piston with rings and pin 0.32 kg lbs

Make Mitsubishi

Model A82

F. A. Rec. No

FOUR STROKE ENGINES

170. Number of camshafts 1 171. Location Cylinder Block  
 172. Type of camshaft drive Chain  
 173. Type of valve operation Pushrod and Rocker

INLET (see page 8) \*

180. Material(s) of inlet manifold Aluminium Alloy  
 181. Diameter of valves 35 mm 1.38 inches  
 182. Max. valve lift 8.2 mm 0.323 in. 183. Number of valve springs 1  
 184. Type of spring Coil 185. Number of valves per cylinder 1  
 186. Tappet clearance for checking timing (cold) 0.05 mm inches  
 187. Valves open at (with tolerance for tappet clearance indicated) 22° ± 2.5° B. T. D. C.  
 188. Valves close at (with tolerance for tappet clearance indicated) 62° ± 2.5° A. B. D. C.  
 189. Air filter, type Dry

EXHAUST (see page 8)

195. Material (s) of exhaust manifold Cast-Iron  
 196. Diameter of valves 28 mm 1.10 inches  
 197. Max. valve lift 8.2 mm 0.323 in. 198. Number of valve springs 1  
 199. Type of spring Coil 200. Number of valves per cylinder 1  
 201. Tappet clearance for checking timing (cold) 0.15 mm inches  
 202. Valves open at (with tolerance for tappet clearance indicated) 62° ± 2.5° B. B. D. C.  
 203. Valves close at (with tolerance for tappet clearance indicated) 22° ± 2.5° A. T. D. C.

CARBURETION (photograph N)

210. Number of carburetors fitted 1 211. Type Down Draught  
 212. Make AISAN 213. Model DW28  
 214. Number of mixture passages per carburetor 2  
 215. Flange hole diameter of exit port(s) of carburetor Primary 28 mm in.  
 Secondary 28  
 216. Minimum dimensions of mixture passage (s) ~~with mixture of max. check to max. check~~  
 Primary 19 mm inches  
 Secondary 24

INJECTION (if fitted)

220. Make of pump 221. Number of plungers  
 222. Model or type of pump 223. Total number of injectors  
 224. Location of injectors  
 225. Minimum diameter of inlet pipe mm inches

\* ) for additional information concerning two-stroke engines and super-charged engines see page 13.

Make Mitsubishi

Model A82

F. I. A. Rec. No.

**ENGINE ACCESSORIES**

- 230. Fuel pump : mechanical and electric
- 231. No. fitted 1
- 232. Type of ignition system Make and Break Ignition
- 233. No. of distributors 1
- 234. No. of ignition coils 1
- 235. No. of spark plugs per cylinder 1
- 236. Generator, type dynamo/alternator-number fitted 1
- 237. Method of drive V Belt
- 238. Voltage of generator 12 volts
- 239. Battery, number 1
- 240. Location Engine Room
- 241. Voltage of battery 12 volts

**ENGINE AND CAR PERFORMANCES** (as declared by manufacturer in catalogue)

- 250. Max. engine output 58 PS (type of horsepower: JIS ) at 6000 rpm
- 251. Maximum rpm 6500 output at that figure 57 PS
- 252. Maximum torque 8.2 kg-m at 3800 rpm
- 253. Maximum speed of the car 140 km/hour miles / hour

255.

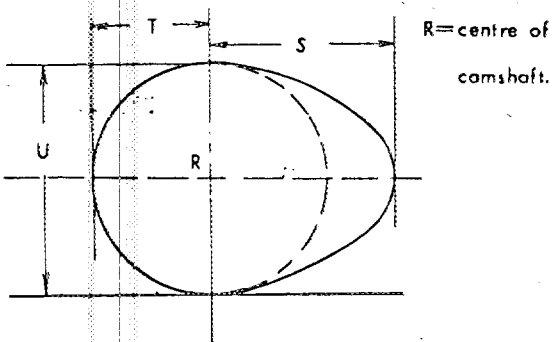

Inlet cam

|     |      |    |       |        |
|-----|------|----|-------|--------|
| s = | 20.6 | mm | 0.811 | inches |
| T = | 15.0 | mm | 0.591 | inches |
| U = | 30.0 | mm | 1.181 | inches |

Exhaust cam

|     |      |    |       |        |
|-----|------|----|-------|--------|
| s = | 20.6 | mm | 0.811 | inches |
| T = | 15.0 | mm | 0.591 | inches |
| U = | 30.0 | mm | 1.181 | inches |

Drawing inlet manifold ports, side of cylinder-head. Indicate scale or dimensions and manufacturing tolerance.

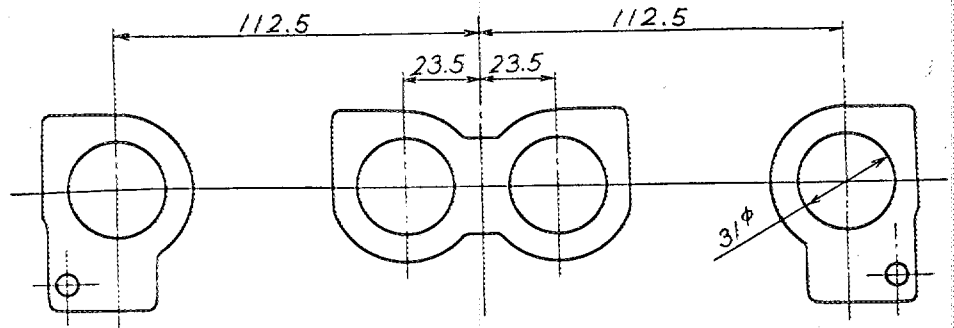

Drawing of entrance to inlet port of cylinder-head. Indicate scale or dimensions and manufacturing tolerance.

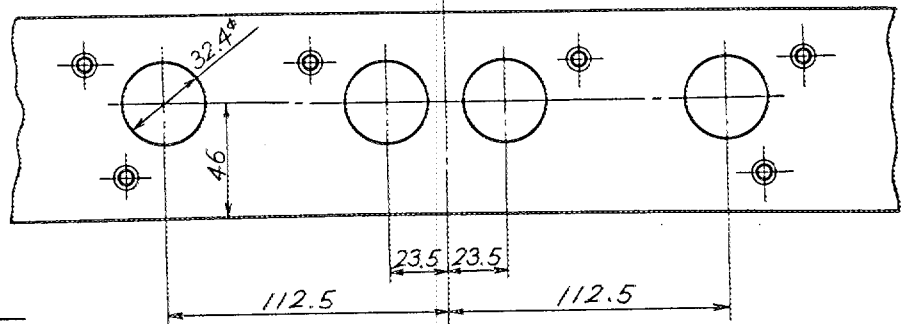

Drawing exhaust manifold ports, side of cylinder-head. Indicate scale or dimensions and manufacturing tolerance.

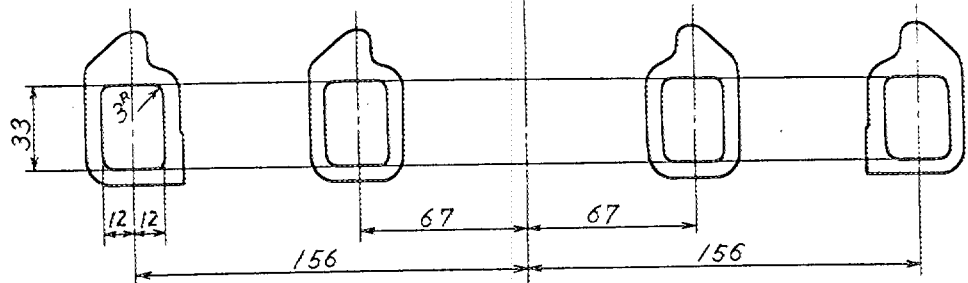

Drawing of exit to exhaust port of cylinder-head. Indicate scale or dimensions and manufacturing tolerance.

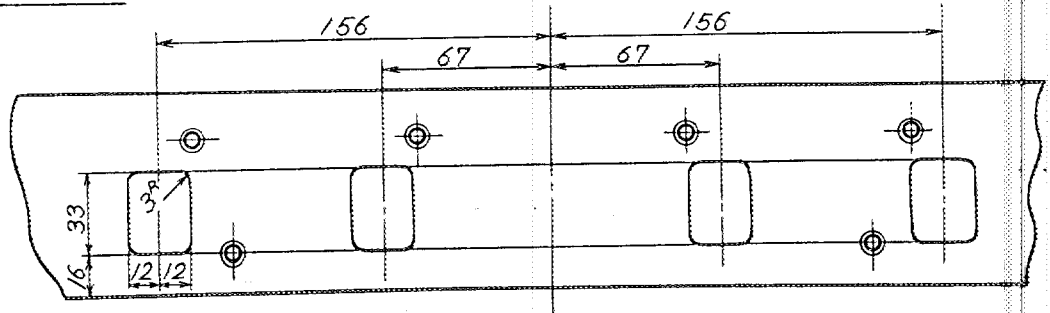

Unit; mm  
Tolerance;  $\pm 1.5$



Make Mitsubishi

Model A82

F. i. A. Rec. No.

**DRIVE TRAIN**

**CLUTCH**

- 260. Type of clutch Dry Single Plate 261. No. of plates 1
- 262. Dia. of clutch plates 18.5 cm inches
- 263. Dia. of linings, inside 12.7 cm in. outside 18.4 cm in.
- 264. Method of operating clutch Hydraulic

**GEAR BOX** (photograph H)

- 270. Manual type, make Mitsubishi Method of operation Mechanical
- 271. No. of gear-box ratios forward 4 272. Synchronized forward ratios 1, 2, 3, 4
- 273. Location of gear-shift Floor
- 274. Automatic, make type
- 275. No. of forward ratios 276. location of gear-shift

| 277.    | Manual |                     | Automatic |           | Alternative manual        |                           |       |           |
|---------|--------|---------------------|-----------|-----------|---------------------------|---------------------------|-------|-----------|
|         | Ratio  | No. teeth           | Ratio     | No. teeth | Ratio                     | No. teeth                 | Ratio | No. teeth |
| 1       | 3.787  | (35/19x37/18)       |           |           | { 3.490 (35/19x36/19)     | 3.132 (35/19x34/20)       |       |           |
|         |        |                     |           |           | { 3.787 (35/19x37/18)     |                           |       |           |
| 2       | 2.379  | (35/19x31/24)       |           |           | 2.211 (35/19x30/25)       | 1.910 (35/19x28/27)       |       |           |
| 3       | 1.535  | (35/19x25/30)       |           |           | { 1.426 (35/19x24/31)     | 1.652 (35/19x26/29)       |       |           |
|         |        |                     |           |           | { 1.324 (35/19x23/32)     | 1.324 (35/19x23/32)       |       |           |
| 4       | 1.000  |                     |           |           | 1.000                     | 1.000                     |       |           |
| 5       |        |                     |           |           |                           |                           |       |           |
| 6       |        |                     |           |           |                           |                           |       |           |
| reverse | 5.243  | (35/19x21/13x37/21) |           |           | 5.243 (35/19x21/13x37/21) | 5.243 (35/19x21/13x37/21) |       |           |

- 278. Overdrive, type
- 279. Forward gears on which overdrive can be selected
- 280. Overdrive ratio

**FINAL DRIVE**

- 290. Type of final drive Hypoid Gear
- 291. Type of differential Bevel Gear
- 292. Type of limited slip differential (if fitted) —
- 293. Final drive ratio 3.889 4.222 4.625 4.875 5.428
- Number of teeth 35/9 38/9 37/8 39/8 38/7

Make Mitsubishi

Model A82

F. I. A. Rec. No.

IMPORTANT - The conformity of the car with the following items of the present recognition form is to be disregarded during the scrutineering, when the vehicle has been entered in group 2 (Touring cars) or 3 (Grand Touring cars) : 41, 72, 80, 91, 142, 143, 144, 145, 146, 153, 156, 157, 160, 161, 162, 163, 164, 182, 184, 186, 187, 188, 189, 199, 201, 202, 203, 212, 213, 215, 216, 222, 225, 230, 250, 251, 252, 253, and photographs I, M, N, and page 8

During the scrutineering of cars entered in group 4 (Sportscars) only the following items of the present recognition form are to be taken into consideration : 1, 2, 3, 9, 20, 21, 22, 23, 24, 25, 26, 70, 71, 78, 79, 90, 130, 131, 132, 133, 134, 135, 136, 137, 138, 139, 140, 141, 147, 148, 149, 150, 158, 159, 170, 171, 172, 173, 185, 200, 270, 271, 274, 275, 290, 291, 292 and photographs A, B, D, E, F, G, H, J, K, and O.

Optional equipment affecting preceding information. This to be stated together with reference number.

|     |                       |          |                |
|-----|-----------------------|----------|----------------|
| 7.  | Capacity of fuel tank | 80 Ltrs. | 21.1 Gallon US |
| 53. | <u>Rim diameter</u>   | 304 mm   | 12.0 inches    |
| 54. | <u>Rim width</u>      | 102 mm   | 4.0 inches     |

• Three door sedan (Photograph A, B)

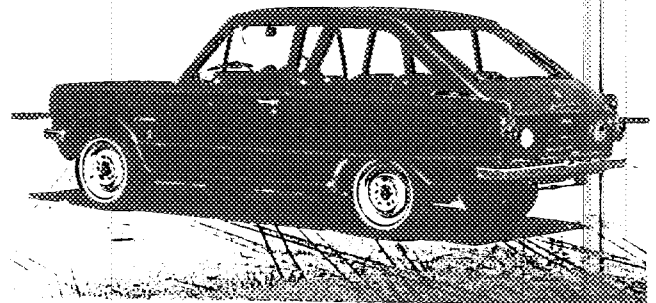

The model produced on the same line as 2 door sedan.

Photograph

interior view of car through driver's door (open or removed) with dashboard

B, 3/4 view of car from rear

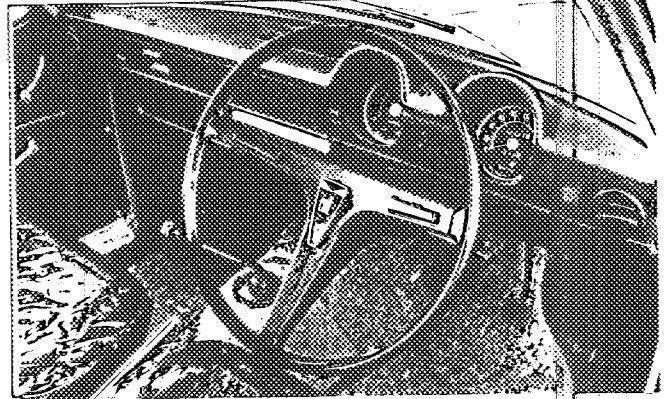
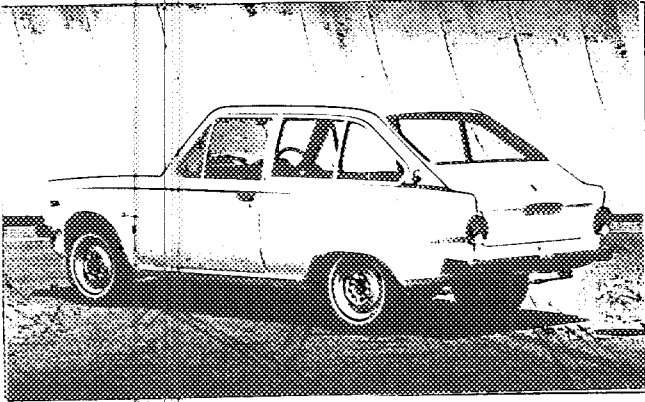

D, front axle complete, removed from car. Without wheels.

E, Rear axle complete without wheels, removed from car.

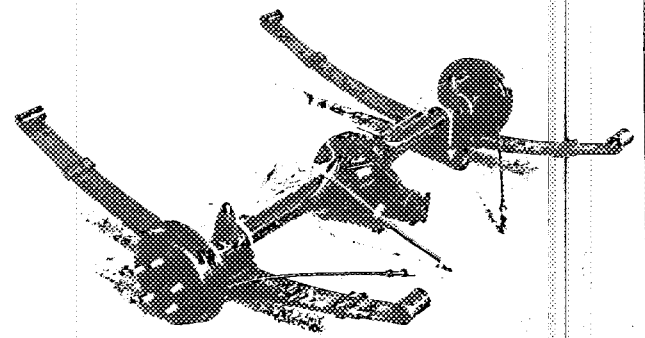
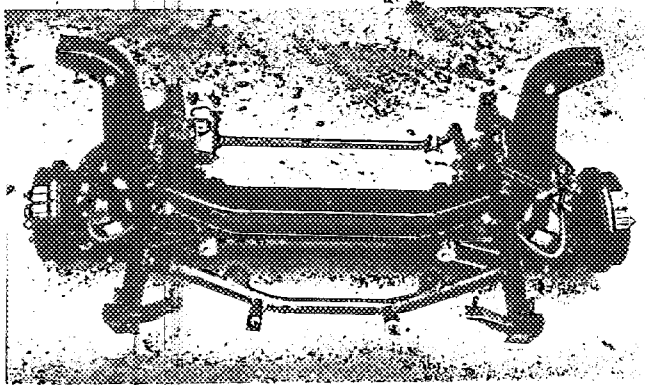

F, front brake, drum removed or disc with caliper(s)

G, rear brake, drum removed or disc with caliper(s)

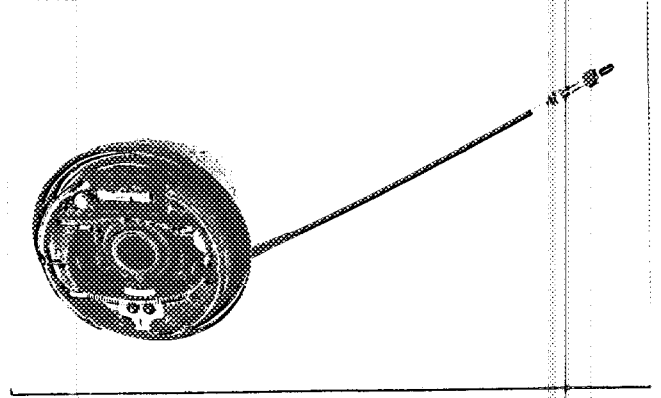
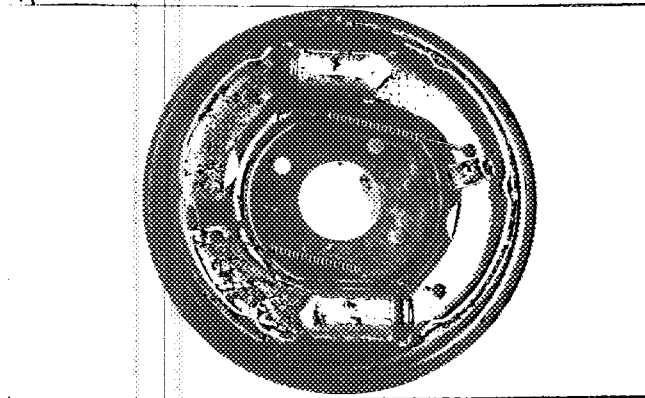

H, gear-box, view from side

I, silencer + exhaust pipes after exhaust manifold

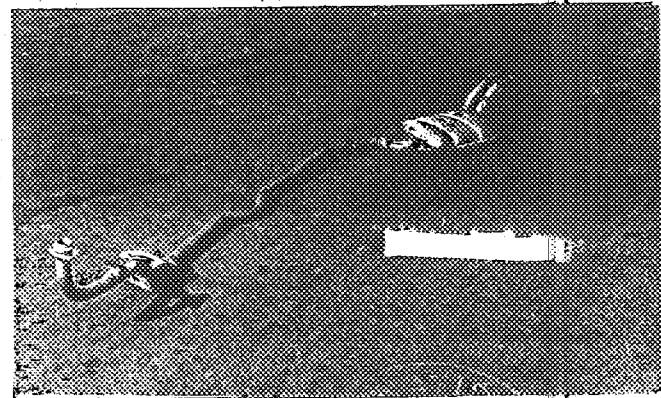
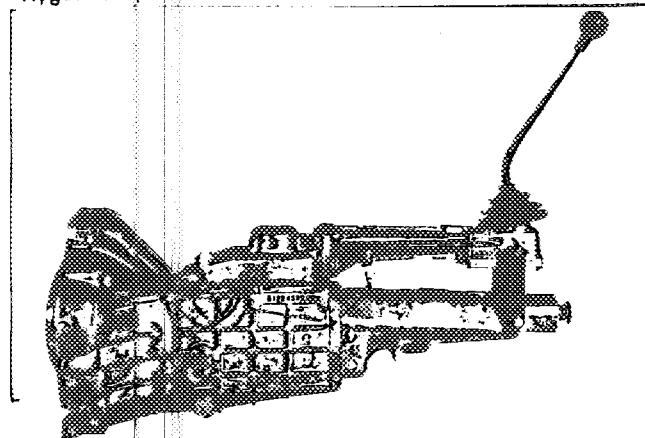

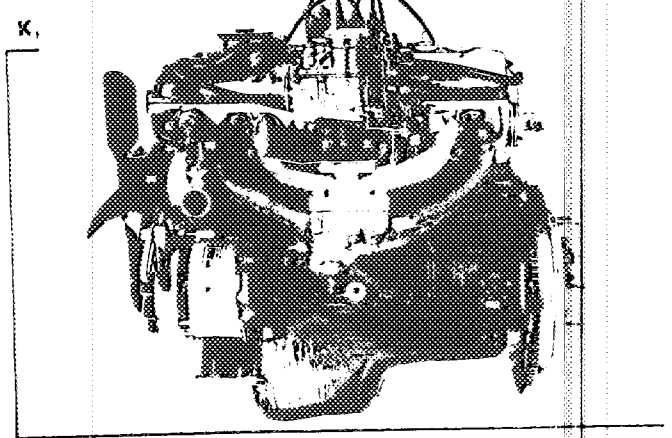
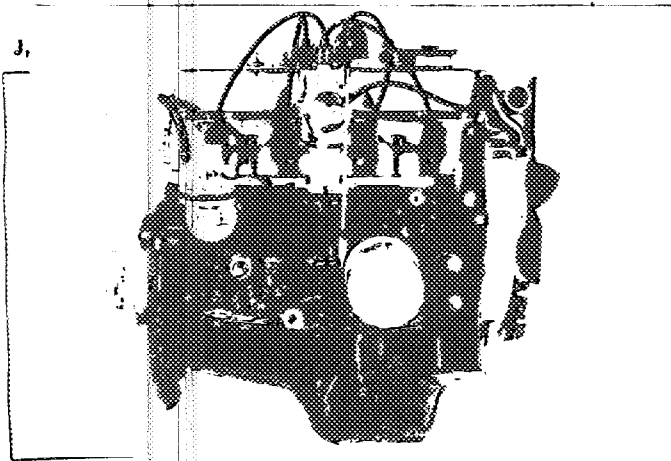

L, combustion chamber

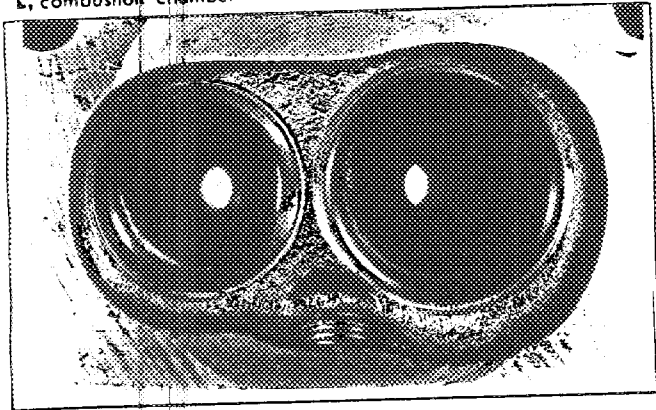

M, piston crown

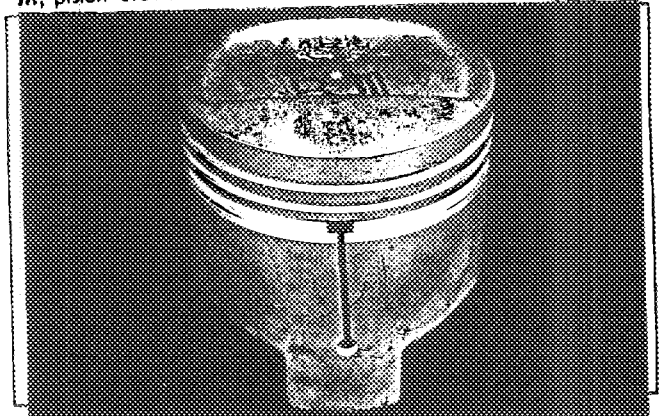

N, Carburetor (view from side of manifold)

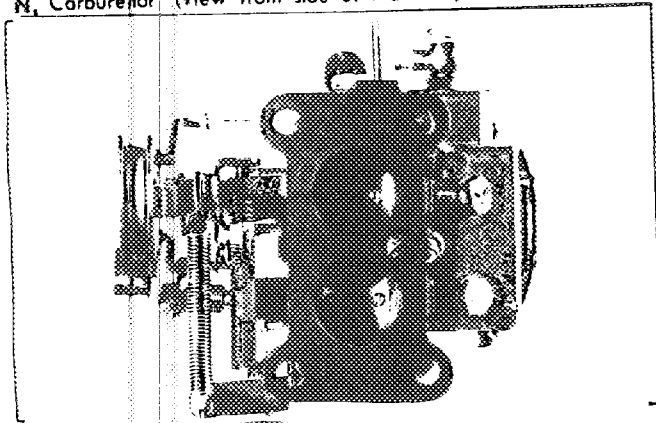

O, engine in car with all accessories, bonnet open or removed.

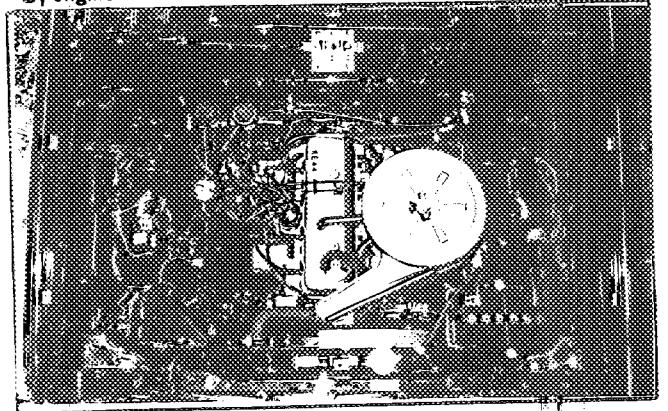

P, inlet manifold

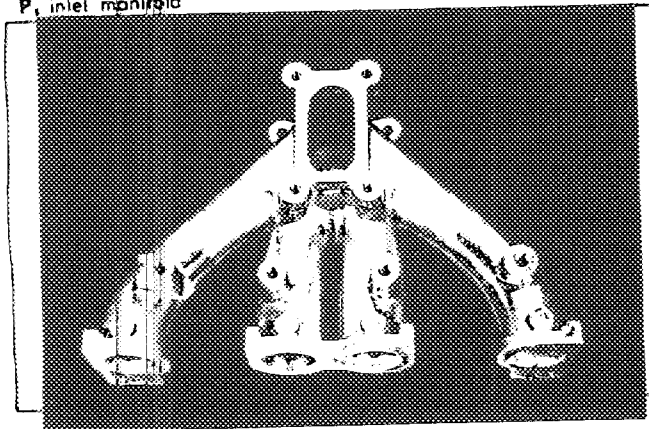

Q, exhaust manifold

