

F.I.A. Recognition No. 1549

Group 2 - Touring



# ROYAL AUTOMOBILE CLUB

31, Belgrave Square, London, S.W.1

Form of recognition in accordance with appendix J to the International Sporting Code of the  
FEDERATION INTERNATIONALE DE L'AUTOMOBILE

Cylinder-capacity 2498 cm.<sup>3</sup> 152 in.<sup>3</sup>

Manufacturer STANDARD TRIUMPH MOTOR CO Model TRIUMPH 2.5 PI.

Serial No. of chassis/body M.D. 1 ONWARDS Manufacturer STANDARD TRIUMPH MOTOR CO

Serial No. of engine CR. 1 HE OR LE ONWARDS Manufacturer STANDARD TRIUMPH MOTOR CO

Recognition is valid from 1st Jan 1969 List 1969/1

The manufacturing of the model described in this recognition form started on 3<sup>rd</sup> MAY 1968

and the minimum production of 1000 identical cars, in accordance with the specifications of

this form was reached on 1-11-68 1968

Photograph A,  $\frac{3}{4}$  view of car from front



F.I.A. Stamp

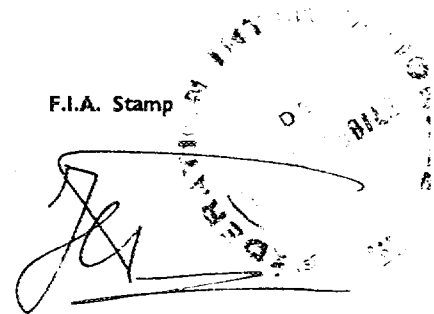

R.A.C. Stamp

B

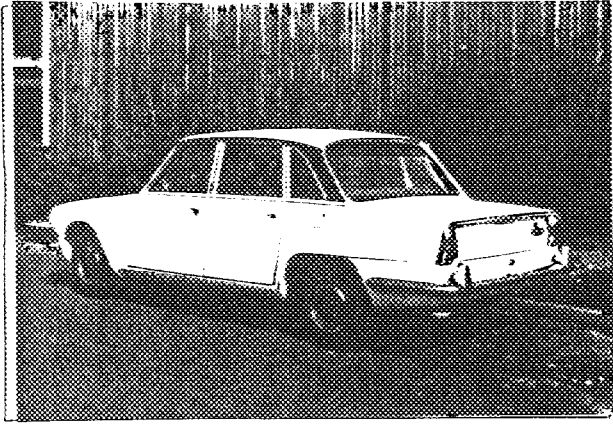

C

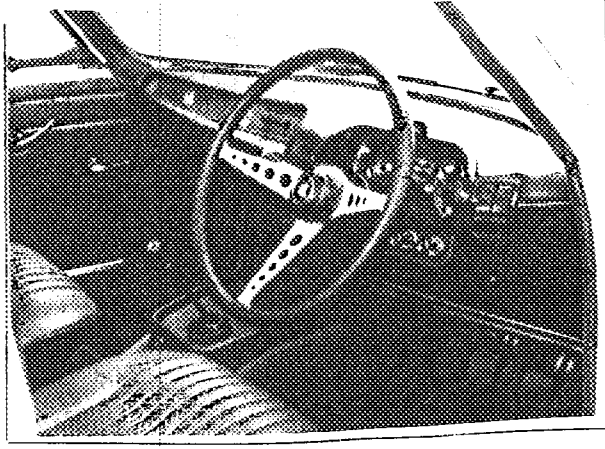

D

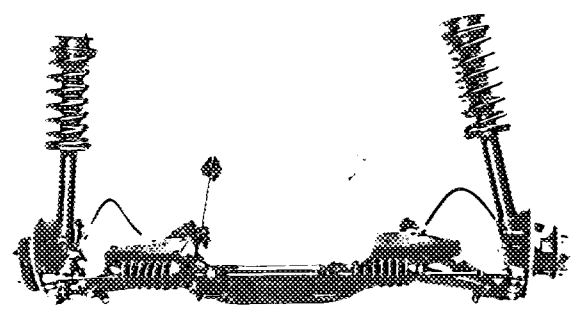

E

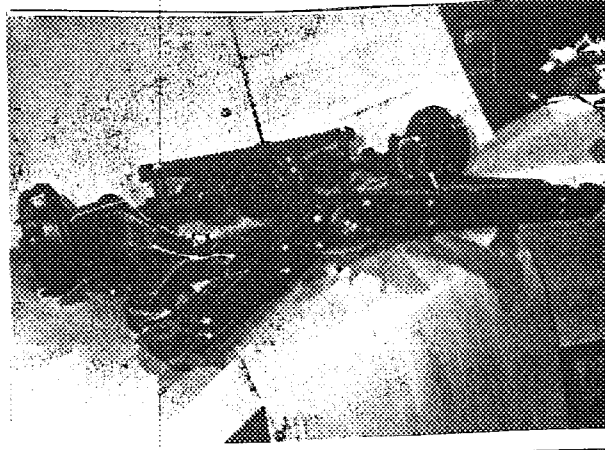

F

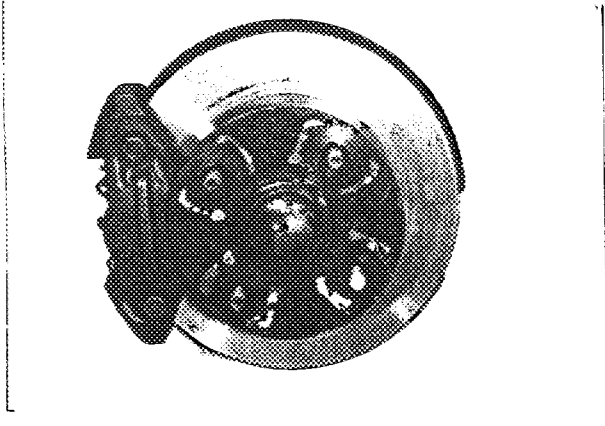

G

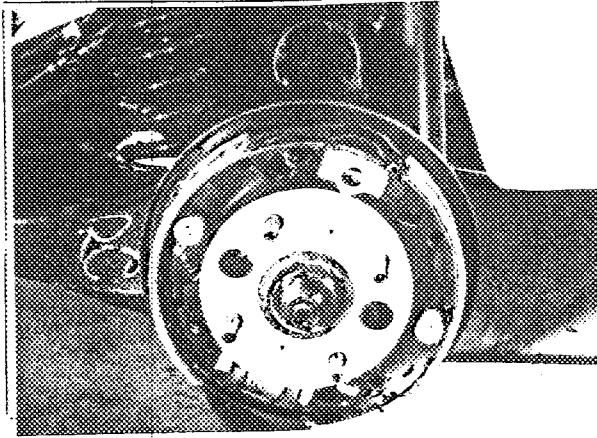

H

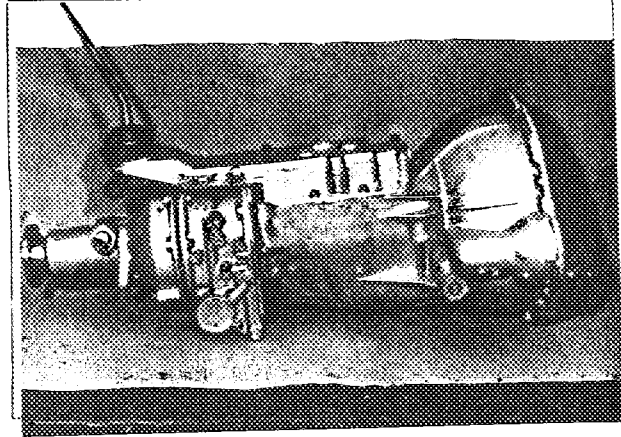

I

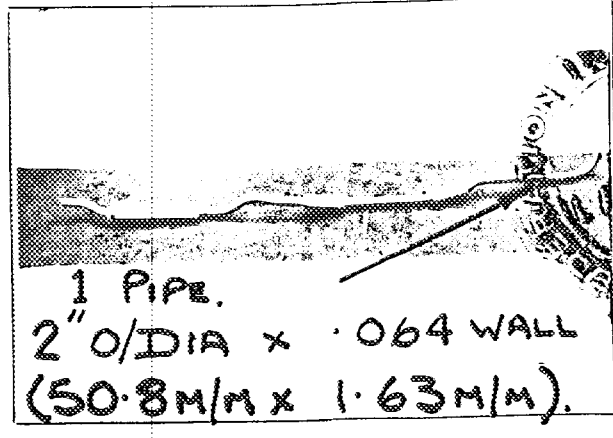

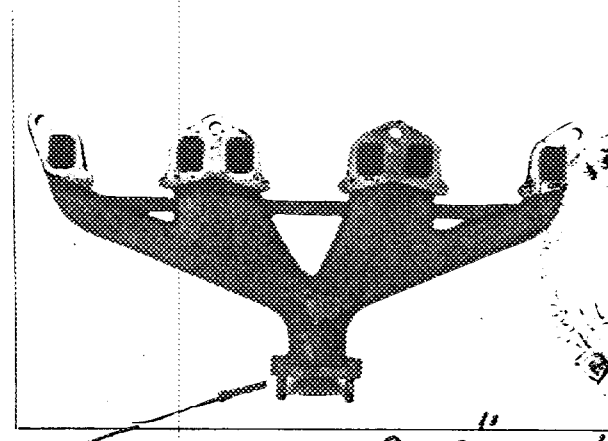
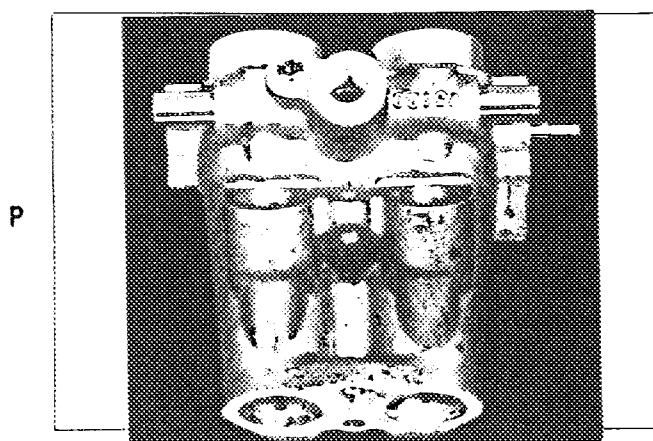
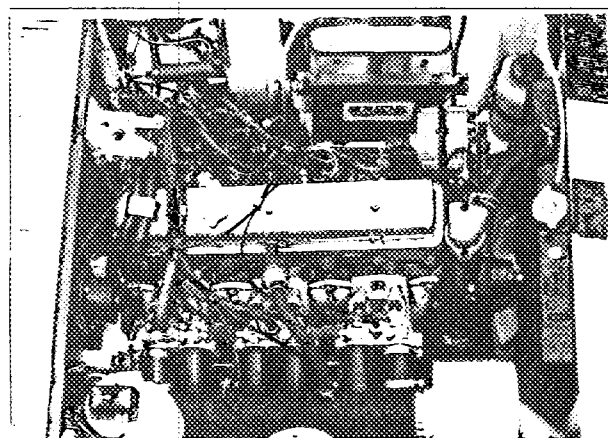
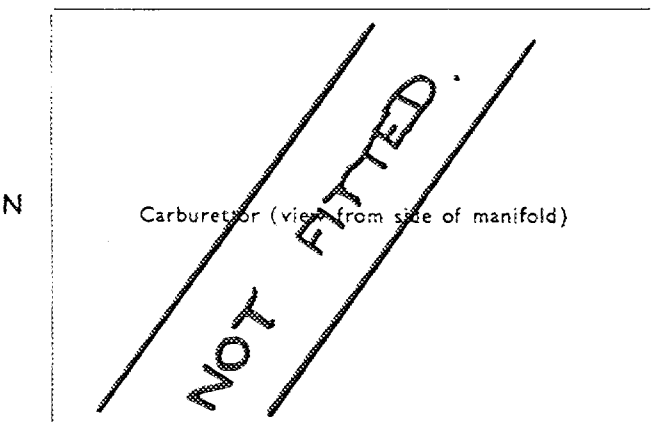
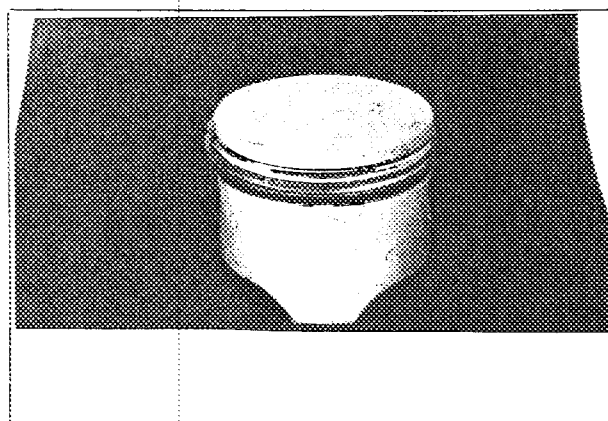
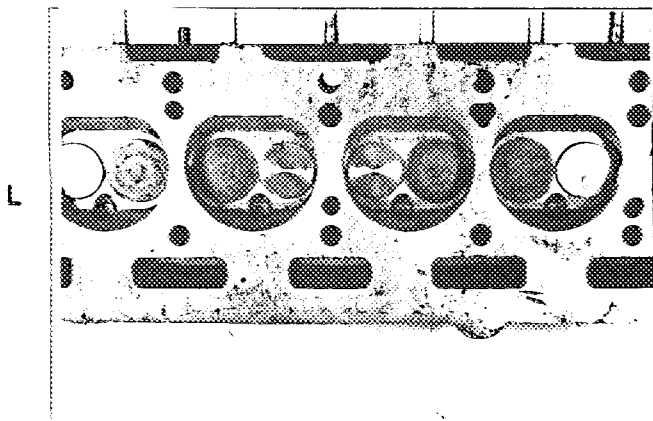
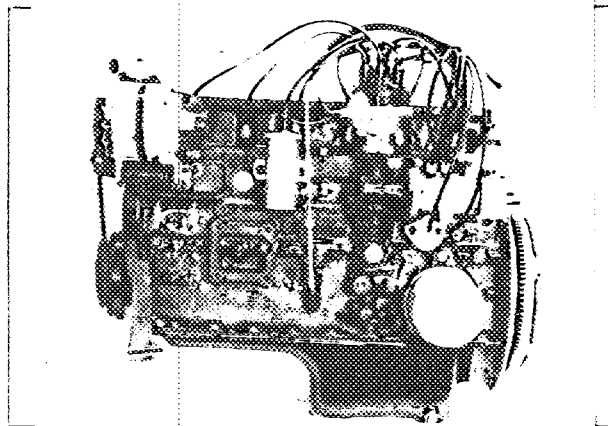
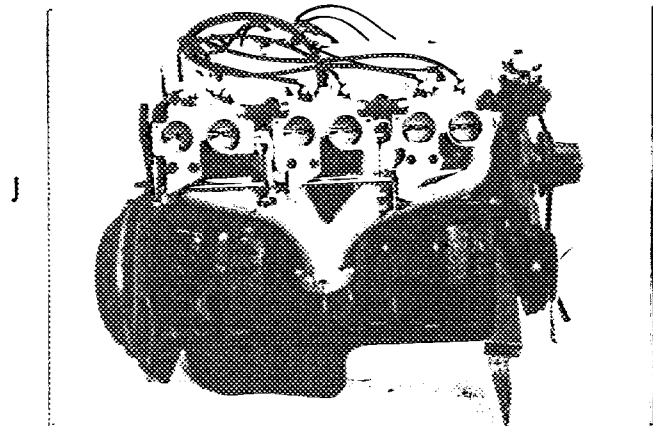

3 SINGLE EXIT 2.03 DIA (51.56) M/M.

Drawing inlet manifold ports, side of cylinderhead. Indicate scale or dimensions and manufacturing tolerance.

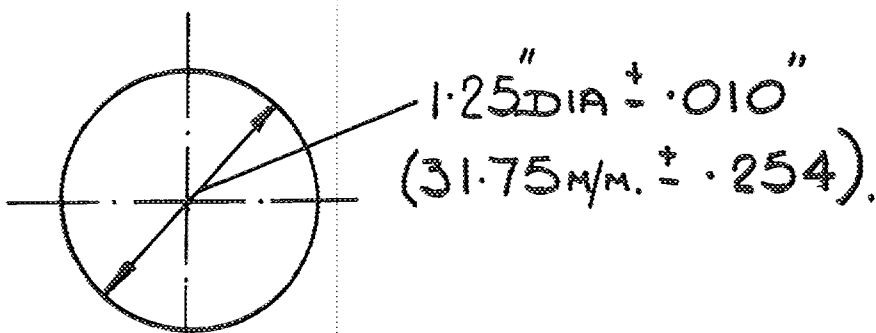

Drawing of entrance to inlet port of cylinderhead. Indicate scale or dimensions and manufacturing tolerance.

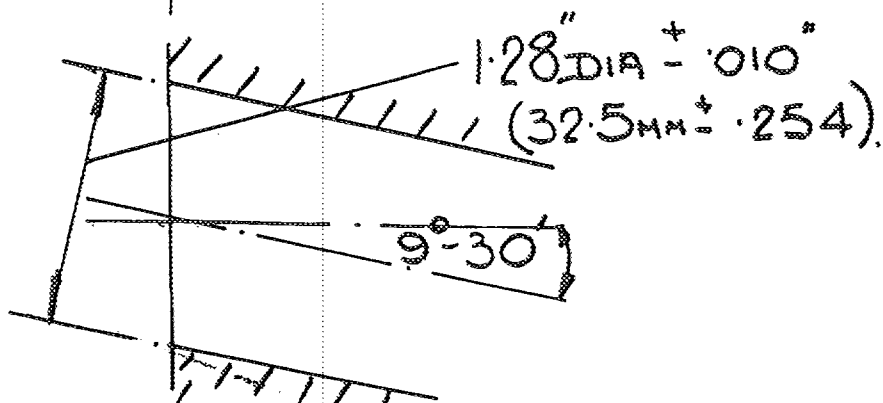

Drawing of exhaust manifold ports, side of cylinderhead. Indicate scale or dimensions and manufacturing tolerance.

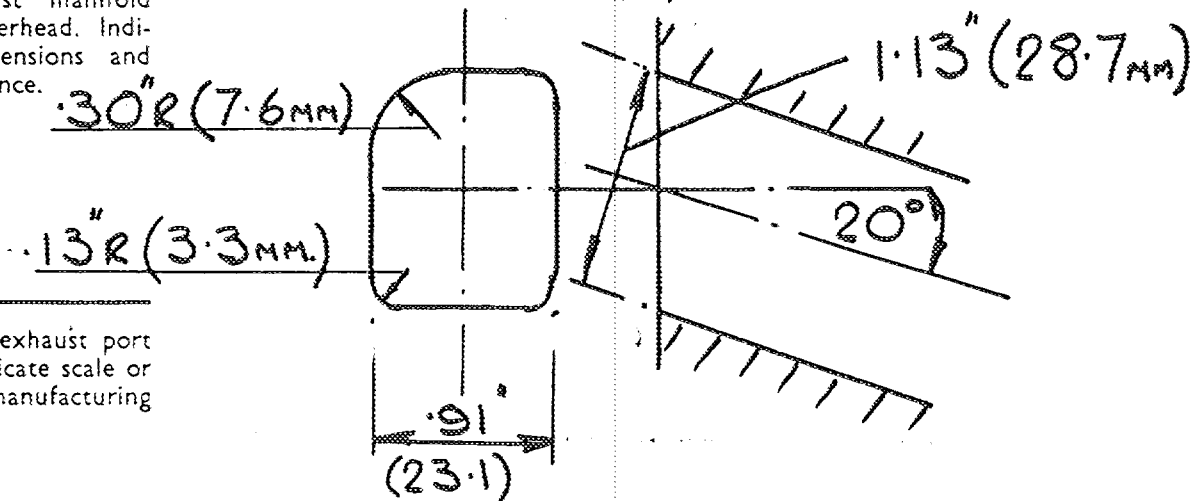

Drawing of exit to exhaust port of cylinderhead. Indicate scale or dimensions and manufacturing tolerance.

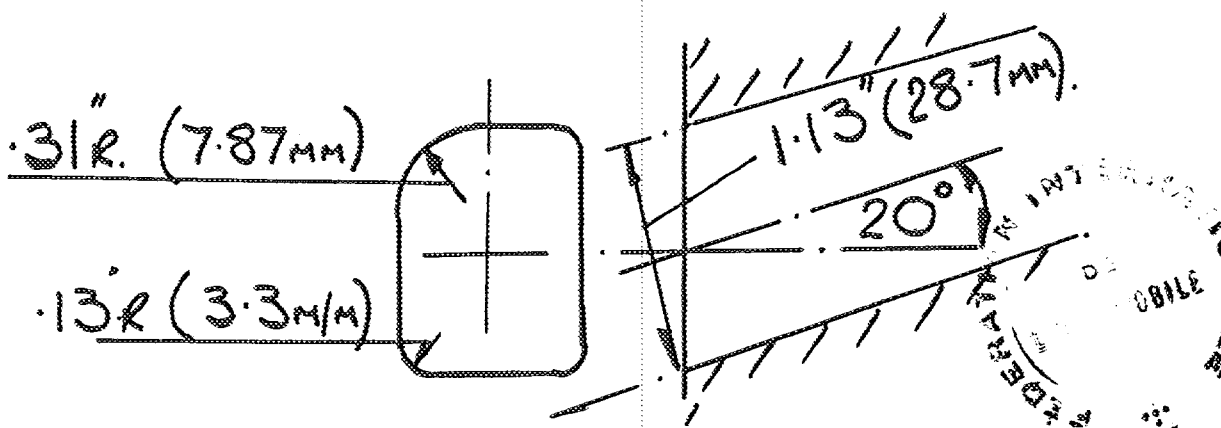

Make **TRIUMPH**

Model **2.5. P.I**

F.I.A. Rec. No.

**NOTE 1.**

All dimensions must be given in two measuring systems, see Note 3.

**CAPACITIES AND DIMENSIONS**

- |                |                 |   |
|----------------|-----------------|---|
| 1. Wheelbase   | <b>2690</b> mm. | <b>106</b> inches                         |
| 2. Front track | <b>1320</b> mm. | <b>52</b> inches                          |
| 3. Rear track  | <b>1280</b> mm. | <b>50<sup>3</sup>/<sub>8</sub></b> inches |

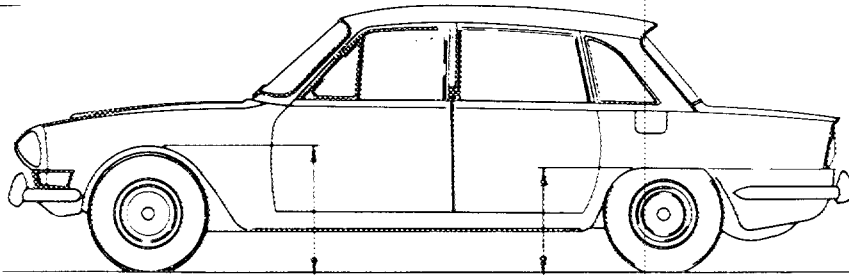

**WING HEIGHTS**

<b>FRONT</b>	<b>REAR</b>
26 INCHES	23.75 INCHES
66.04 CMS.	60.32 CMS.

6.50 x 13 DUNLOP C41 — FULL FUEL TANK.

- |   |                   |                        |  |
|---|-------------------|------------------------|--|
| 4. Overall length of the car  | <b>441.5</b> cm.  | <b>173.75</b> inches   |  |
| 5. Overall width of the car   | <b>165.0</b> cm.  | <b>65</b> inches       |  |
| 6. Overall height of the car  | <b>142.0</b> cm.  | <b>56</b> inches       |  |
| 7. Capacity of fuel tank (reserve included)   | <b>63.6</b> ltrs. | <b>16.8</b> gall. U.S. | <b>14</b> gall. Imp.                     |
| 8. Seating Capacity.  | <b>4/5</b>        |                        |  |
| 9. Weight. Total weight of the car with normal equipment, water, oil, and spare wheel but without fuel or repair tools: | <b>1143</b> kg.   | <b>2520</b> lbs.       | <b>22<sup>1</sup>/<sub>2</sub></b> cwts. |

**NOTE 2.**

Differences in track caused by the use of other wheels with different rim widths must be stated when recognition is requested for the wheels concerned. Specify ground clearance in relation to the track and give drawing of two easily recognisable points at front and rear at which measurements are taken. These ground clearance dimensions are only for information when checking the track and can in no way affect the eligibility of the car.

**NOTE 3.**

**CONVERSION TABLE**

1 inch/pouce	— 2.54	cm.	1 quart US	— 0.9464	ltrs.
1 foot/pied	— 30.4794	cm.	1 pint (pt)	— 0.568	ltrs.
1 sq. inch/pouce carre	— 6.452	cm. <sup>2</sup>	1 gallon Imp.	— 4.546	ltrs.
1 cubic inch/pouce cube	— 16.387	cm. <sup>3</sup>	1 gallon US	— 3.785	ltrs.
1 pound/livre (lb)	— 453.593	gr.	1 hundred weight (cwt.)	— 50.802	kg.

Make **TRIUMPH**

Model **2.5 P.I.**

F.I.A. Rec. No. ....

CHASSIS AND COACHWORK (Photographs A, B and C)

- 20. Chassis/body construction: ~~SEPARATE~~/unitary construction
- 21. Unitary construction, material(s) **STEEL**
- 22. Separate construction, Material(s) of chassis **N.A.**
- 23. Material(s) of coachwork **STEEL**
- 24. Number of doors **4** Material(s) **STEEL.**
- 25. Material(s) of bonnet **STEEL.**
- 26. Material(s) of boot lid **STEEL.**
- 27. Material(s) of rear-window **GLASS.**
- 28. Material(s) of windscreen **LAMINATED GLASS.**
- 29. Material(s) of front-door windows **GLASS**
- 30. Material(s) of rear-door windows **GLASS**
- 31. Sliding system of door windows **REMOTE WINDER.**
- 32. Material(s) of rear-quarter light **GLASS**

ACCESSORIES AND UPHOLSTERY

- 38. Interior heating : yes ~~XX~~
- 39. Air conditioning : ~~XX~~—no **SEPERATE.**
- 40. Ventilation : yes ~~XX~~
- 41. Front seats, type of seat and upholstery **LEATHER.**
- 42. Weight of front seat(s), complete with supports and rails, out of the car : **29** lbs.
- 43. Rear seats, type of seat and upholstery **BENCH. LEATHER.** **13.1** kg.
- 44. Front bumper, material(s) **STEEL** Weight **4.76** kg. **10 1/2** lbs.
- 45. Rear bumper, material(s) **STEEL** Weight **5.2** kg. **11 1/2** lbs.

WHEELS

- 50. Type **STEEL DISC.**
- 51. Weight (per wheel, without tyre) **6.12** kg. **13 1/2** lbs.
- 52. Method of attachment **4 STUD & NUT.**
- 53. Rim diameter **330** mm. **13** ins. 54. Rim width **114** mm. **4.5** ins.

STEERING

- 60. Type **RACK & PINION**
- 61. Servo-assistance : ~~XX~~—no
- 62. Number of turns of steering wheel from lock to lock **4.**
- 63. In case of servo-assistance **N.A.**

SUSPENSION

70. Front suspension (photograph D), type **INDEPENDANT. TELESCOPIC STRUT.**  
 71. Type of spring **COIL**  
 72. Stabiliser (if fitted) **—**  
 73. Number of shock absorbers **1 PER SIDE** 74. Type **TELESCOPIC.**  
 78. Rear suspension (photograph E), type **INDEPENDANT. SEMI-TRAILING ARMS.**  
 79. Type of spring **COIL**  
 80. Stabiliser (if fitted) **—**  
 81. Number of shock absorbers **1 PER SIDE** 82. Type **TELESCOPIC.**

BRAKES (photographs F and G)

90. Method of operation **PEDAL OPERATED HYDRAULIC.**  
 91. Servo-assistance (if fitted), type **LOCKHEED TYPE 8. REMOTE.**

92. Number of hydraulic master cylinders **1**  
 93. Number of cylinders per wheel **2**  
 94. Bore of wheel cylinder(s) **54** mm. **2 1/8** inches **FRONT** | **27** mm. **1 1/16** inches **REAR**

Drum Brakes

95. Inside diameter mm. inches **228** mm. **9** inches  
 96. Length of brake linings mm. inches **445** mm. **17.5** inches  
 97. Width of brake linings mm. inches **44.5** mm. **1.75** inches  
 98. Number of shoes per brake **2**  
 99. Total area per brake mm.<sup>2</sup> sq. in. **19500** mm.<sup>2</sup> **3025** sq. in.

Disc Brakes

100. Outside diameter mm. inches **249** mm. **9.75** inches  
 101. Thickness of disc mm. inches **12.7** mm. **.5** inches  
 102. Length of brake linings mm. inches **79.5** mm. **3.125** inches  
 103. Width of brake linings mm. inches **47.6** mm. **1.875** inches  
 104. Number of pads per brake **2**  
 105. Total area per brake mm.<sup>2</sup> sq. in. **6450** mm.<sup>2</sup> **10** sq. in.

ENGINE (photographs J and K)

130. Cycle **4 STROKE.** 131. Number of cylinders **6**
132. Cylinder Arrangement **IN LINE.**
133. Bore **74.7** mm. **2.94** in. 134. Stroke **95** mm. **3.74** in.
135. Capacity per cylinder **416.3** cm.<sup>3</sup> **25.3** cu. in.
136. Total cylinder capacity **2498** cm.<sup>3</sup> **152** cu. in.
137. Material(s) of cylinder block **CHROME IRON** 138. Material(s) of sleeves (if fitted) **-**
139. Cylinder head, material(s) **CHROME IRON.** Number fitted **1**
140. Number of inlet ports **6** 141. Number of exhaust ports **6**
142. Compression ratio **9.5:1**
143. Volume of one combustion chamber **43.32** cm.<sup>3</sup> **2.64** cu. in.
144. Piston, material **ALUMINIUM ALLOY** 145. Number of rings **3**
146. Distance from gudgeon pin centre line to highest point of piston crown **29** mm. **1.141** in.
147. Crankshaft: ~~xxx~~/stamped 148. Type of crankshaft: integral/~~xxx~~
149. Number of crankshaft main bearings **4**
150. Material of bearing cap **CHROME IRON.**
151. System of lubrication: ~~xxxx~~/oil in sump
152. Capacity, lubricant **4.52** ltrs. **8** pts. **4.8** quarts U.S.
153. Oil cooler: ~~xx~~/no 154. Method of engine cooling **WATER.**
155. Capacity of cooling system **7.66** ltrs. **13 1/2** pts. **8.1** quarts U.S.
156. Cooling fan (if fitted) dia. **31.8** cm. **12.5** in.
157. Number of blades of cooling fan **8.**

Bearings

158. Crankshaft main, type **SHELL.** dia. **58.8** m.m. **2.313** in.
159. Connecting rod big end, type **SHELL** dia. **47.8** m.m. **1.877** in.

Weights

160. Flywheel (clean) **9.18** kg. **20 1/4** lbs.
161. Flywheel with clutch (all turning parts) **14.6** kg. **32 1/4** lbs.
162. Crankshaft **27.4** kg. **60 1/2** lbs. 163. Connecting rod **.65** kg. **1.43** lbs.
164. Piston with rings and pin **.376** kg. **13 1/4** lbs.



Make **TRIUMPH**

Model **2.5 P.I.**

F.I.A. Rec. No.

FOUR STROKE ENGINES

- 170. Number of camshafts **1** 171. Location **SIDE OF GYL BLOCK.**
- 172. Type of camshaft drive **DUPLEX CHAIN.**
- 173. Type of valve operation **PUSH ROD OPERATED O.H.V.**

INLET (see page 4)\*

- 180. Material(s) of inlet manifold **ALUMINIUM ALLOY.**
- 181. Diameter of valves **36.8** mm. **1.443** ins.
- 182. Max. valve lift **8.5** mm. **336** in. 183. Number of valve springs **2**
- 184. Type of spring **COIL** 185. Number of valves per cylinder **1**
- 186. Tappet clearance for checking timing (cold) **.382** mm. **.015** ins.
- 187. Valves open at (with tolerance for tappet clearance indicated) **25° B.T.D.C.**
- 188. Valves close at (with tolerance for tappet clearance indicated) **65° A.B.D.C.**
- 189. Air filter, type **PAPER ELEMENT.**

EXHAUST (see page 4)\*

- 195. Material(s) of exhaust manifold **CAST IRON.**
- 196. Diameter of valves **32** mm. **1.258** ins.
- 197. Max. valve lift **8.5** mm. **336** in. 198. Number of valve springs **2**
- 199. Type of spring **COIL** 200. Number of valves per cylinder **1**
- 201. Tappet clearance for checking timing (cold) **.382** mm. **.015** ins.
- 202. Valves open at (with tolerance for tappet clearance indicated) **65° B.B.D.C.**
- 203. Valves close at (with tolerance for tappet clearance indicated) **25° A.T.D.C.**

CARBURETION (photograph N)

- 210. Number of carburetors fitted
- 212. Make
- 213. Model
- 214. Number of mixture passages per carburetor
- 215. Flange hole diameter of exit port(s) of carburetor mm. ins.
- 216. Minimum diameter of venturi minimum diam., with piston at maximum height (example : SU) mm. ins.

**NOT FITTED**

INJECTION (if fitted)

- 220. Make of pump **LUCAS.** 221. Number of ~~plugs~~ **SHUTTLES.** **1**
- 222. Model or type of pump **730-59** 223. Total number of injectors **6**
- 224. Location of injectors **TOP OF INLET MANIFOLD.**
- 225. Minimum diameter of inlet pipe **31.75** mm. **1.25** ins.

\* For additional information concerning two-stroke engines and super-charged engines, see page 13.

ENGINE ACCESSORIES

- 230. Fuel pump : ~~mechanical~~ or electrical
- 231. No. fitted **1**
- 232. Type of ignition system **COIL**
- 233. No. of distributors **1**
- 234. No. of ignition coils **1**
- 235. No. of spark plugs per cylinder **1**
- 236. Generator, type : ~~AMV~~/alternator—number fitted **1**
- 237. Method of drive **VEE-BELT.**
- 238. Voltage of generator **12** volts
- 239. Battery, number **1**
- 240. Location **UNDER BONNET**
- 241. Voltage of battery **12** volts

ENGINE AND CAR PERFORMANCES (as declared by manufacturer in catalogue)

- 250. Max. engine output **132** (type of horsepower: **B.H.P.**) at **5450** r.p.m.
- 251. Max. r.p.m. **NOT QUOTED** output at that figure **N.Q.**
- 252. Max. torque **1840 LBS IN.** at **2000** r.p.m.
- 253. Max. speed of the car **177** km./hour **110** miles/hour

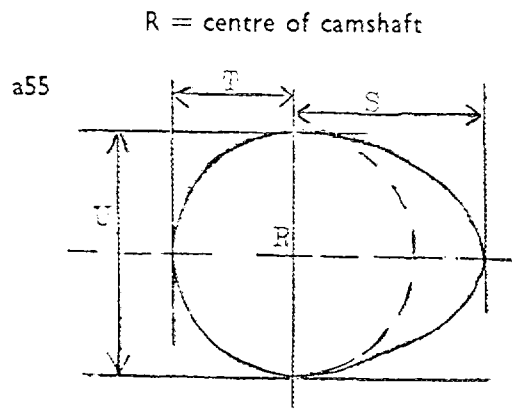

<u>Inlet cam</u>			
S =	19.7	mm.	.774 inches
T =	13.7	mm.	.54 inches
U =	27.2	mm.	1.080 inches
<u>Exhaust cam</u>			
S =	19.7	mm.	.774 inches
T =	13.7	mm.	.54 inches
U =	27.2	mm.	1.080 inches

Make **TRIUMPH**

Model **2.5.P.I.**

F.I.A. Rec. No.

DRIVE TRAIN

CLUTCH

- 260. Type of clutch **DIAPHRAGM.**
- 261. No. of plates **1**
- 262. Dia. of clutch plates **21.6** cm. **8.5** ins.
- 263. Dia. of linings, inside **14.2** cm. **5.75** ins.
- outside **21.4** cm. **8.44** ins.
- 264. Method of operating clutch **HYDRAULIC.**

GEAR BOX (photograph H)

- 270. Manual type, make **TRIUMPH** Method of operation **REMOTE LEVER.**
- 271. No. of gear-box ratios forward **4**
- 272. Synchronized forward ratios **4.**
- 273. Location of gear-shift **CENTRE TUNNEL**
- 274. Automatic, make **BOGE WARNER.** type **35**
- 275. No. of forward ratios **3**
- 276. Location of gear shift **CENTRE TUNNEL.**

277.	Manual		Automatic		Ratio	Alternative manual/automatic		
	Ratio	No. teeth	Ratio	No. teeth		No. teeth	Ratio	No. teeth
1	3.281	$\frac{35}{22} \times \frac{33}{16}$	<del>2.39</del> <del>4.78</del>	<del>8.84</del> <del>17.69</del>				
2	2.100	$\frac{35}{22} \times \frac{33}{25}$	1.45	5.37				
3	1.386	$\frac{35}{22} \times \frac{27}{31}$	2.9	10.73				
4	1.00	DIRECT	1/2	3.7/7.4				
5								
6								
reverse	3.369	$\frac{35}{22} \times \frac{36}{17}$	2.09	7.73				
			4.18	15.47				

- 278. Overdrive, type **LAYCOCK DE NORMANVILLE (ELECTRICALLY OPERATED.)**
- 279. Forward gears on which overdrive can be selected **3rd & 4th**
- 280. Overdrive ratio **.82.**

FINAL DRIVE

- 290. Type of final drive **HYPOID**
- 291. Type of differential **SPUR BEVEL**
- 292. Type of limited slip differential (if fitted) **SEE OPTIONS.**
- 293. Final drive ratio **3.45 & 3.7**
- Number of teeth  **$\frac{38}{11}$  &  $\frac{37}{10}$**

Make **TRIUMPH**

Model **2.5PI**

F.I.A. Rec. No.

**IMPORTANT**—The conformity of the car with the following items of the present recognition form is to be disregarded during the scrutineering, when the vehicle has been entered in group 2 (Touring cars) or 3 (Grand Touring cars) : 41, 72, 80, 91, 142, 143, 144, 145, 146, 153, 156, 157, 160, 161, 162, 163, 164, 182, 186, 187, 188, 189, 201, 202, 203, 212, 213, 215, 216, 222, 225, 230, 250, 251, 252, 253, 255 photographs I, M and N and page 4.

During the scrutineering of cars entered in group 4 (Sportscars) only the following items of the present recognition form are to be taken into consideration : 1, 2, 3, 9, 20, 21, 22, 23, 24, 25, 26, 70, 71, 78, 79, 90, 130, 131, 132, 133, 134, 135, 136, 137, 138, 139, 140, 141, 147, 148, 149, 150, 158, 159, 170, 171, 172, 173, 185, 200, 270, 271, 274, 275, 290, 291, 292 and photographs A, B, D, E, F, G, H, J, K and O.

The vehicle described in this form has been subject to the following amendments :

on	19	rec. no.	List	on	19	rec. no.	List
on	19	rec. no.	List	on	19	rec. no.	List
on	19	rec. no.	List	on	19	rec. no.	List
on	19	rec. no.	List	on	19	rec. no.	List
on	19	rec. no.	List	on	19	rec. no.	List

Optional equipment affecting preceding information. This to be stated together with reference number.

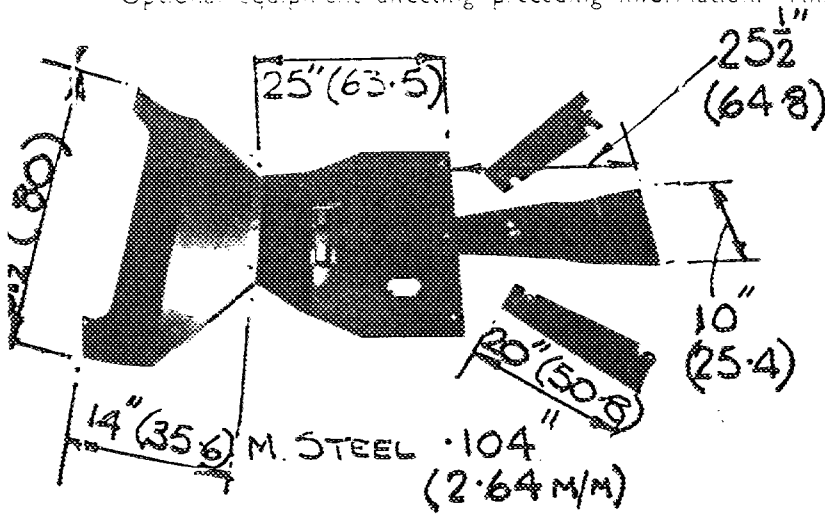

- UNDERSHIELDS
- RADIATOR. 8 1/2 LB. (3.8K) 306826.
  - SUMP 13 LB. (5.8K) 306958.
  - GEARBOX 4 LB. (1.8K) 306971
  - TRAILING ARMS. 3 LB. (1.4K)
- 211569/71.

**NON-OVERDRIVE  
GEARBOX 306757**

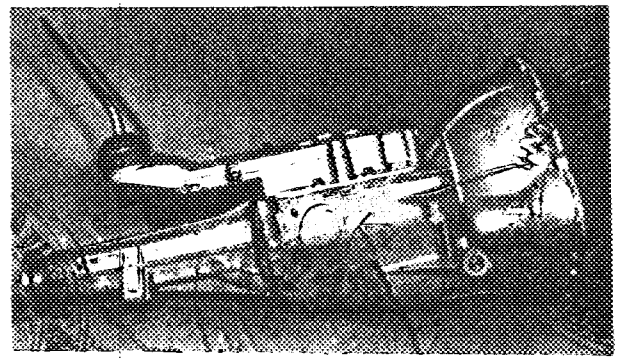

12

LIMITED SLIP DIFFERENTIAL (FRICTION TYPE.) DET N° 212978.

INTERNAL DRIVE RATIO 4.1:1 (N° TEETH 10x41) DET N° 505014.

INTERNAL DRIVE RATIO 4.3:1 (N° TEETH 10x43) DET N° 502523.

INTERNAL DRIVE RATIO 4.5:1 (N° TEETH 9x41) DET N° 503924.

INTERNAL DRIVE RATIO 4.87:1 (N° TEETH 8x39) DET N° 515844.

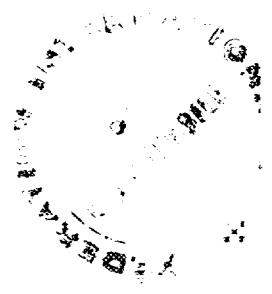

OPERATION UNIT

INSTRUMENT WUFFI BASE

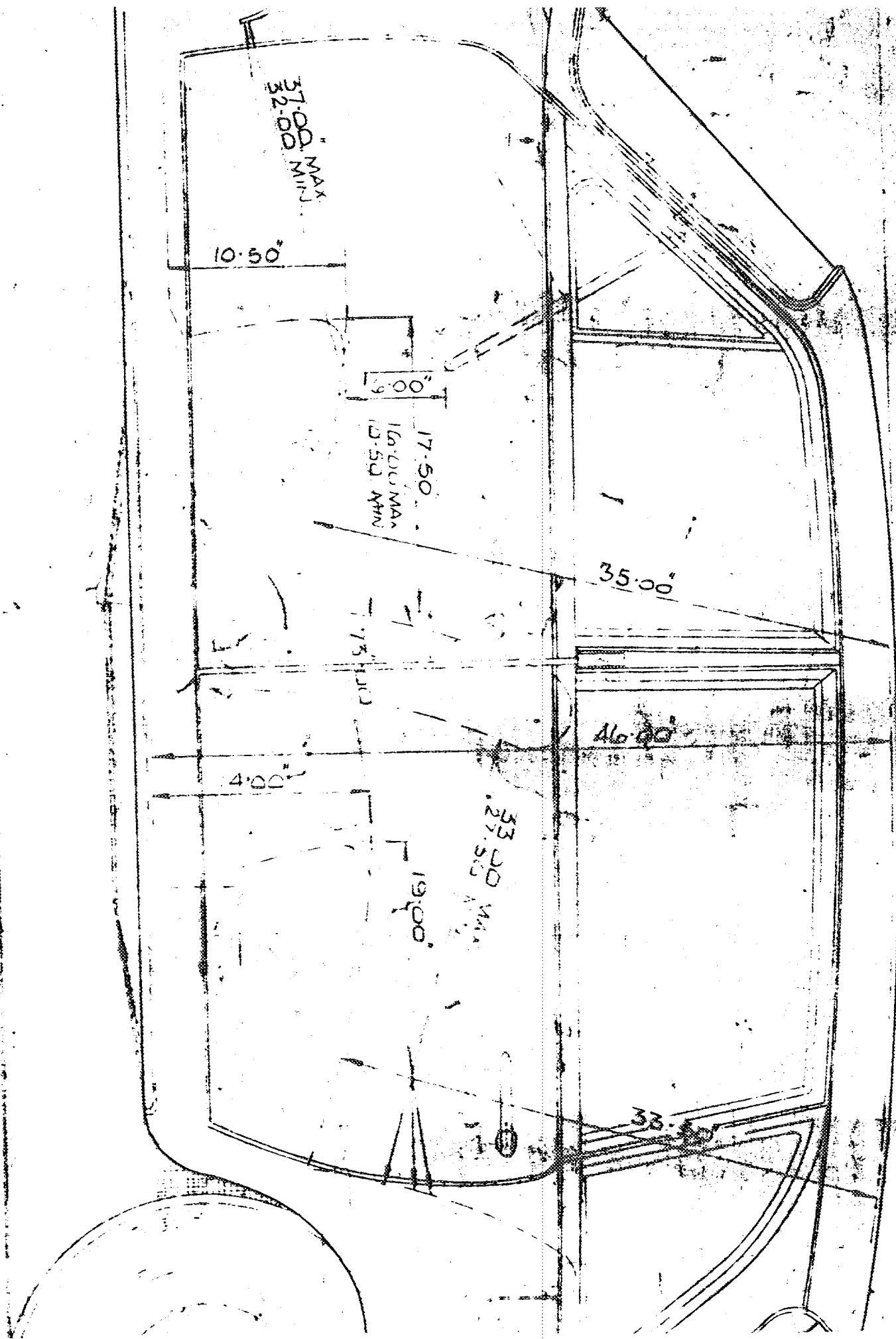



MOTOR SPORT DIVISION  
The Royal Automobile Club,  
31 Belgrave Square, London, S.W.1

Standard Triumph  
Manufacturer Motor Company

Model Triumph 2.5 PI

F.I.A. Recognition No. 1549

Amendment No. 1/1U

Amendment to Form of Recognition

FEDERATION INTERNATIONALE DE L'AUTOMOBILE

No. Reference No.

VARIANT - GROUP 2

- |   |     |   |                         |
|---|-----|---|-------------------------|
| 1 | 50. | Road wheel - Magnesium alloy, Part No. 99-500001. |                         |
|   | 51. | Weight:- 10,5 lbs/4.76 kg.                        |                         |
|   | 52. | 4 studs and nuts.                                 |                         |
|   | 53. | 330.2 mm/13.0 inches                              |                         |
|   | 54. | 177.8 mm/ 7.0 inches.                             |                         |
|   | 2.  | Front track - 1404.6 mm/55.3 inches               | (± 6.35 mm/0.25 inches) |
|   | 3.  | Rear track - 1363.2 mm/53.67 inches               | " " }                   |

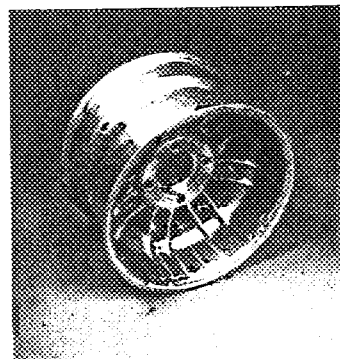

Date amendment is valid from

1st July 1969  
hist 1969/5



Stamp of F.I.A./R.A.C.



FEDERATION INTERNATIONALE DE L'AUTOMOBILE

TRIUMPH 2.5 Pi

MARQUE ET MODELE

1/69

VALIDITE HOMOLOGATION

1549

FICHE NR.

2/2500

GROUPE / CLASSE

EXTENSIONS	DEBUT VALIDITE	DESCRIPTION	NOTES
1/11	7/69	JANTE - VOIE	

Autres homologations du modèle

Vérifiée le 22/7/96 par [Signature] visée ce jour le \_\_\_\_\_ par \_\_\_\_\_