

MAKE Plymouth MODEL Barracuda FIA REC # 1453



Telephone: (203) 348-6233

Cable Address: "ACCUSFIA" Stamford, Conn.

AUTOMOBILE COMPETITION COMMITTEE FOR THE UNITED STATES, FIA, INC.
433 MAIN STREET, STAMFORD, CONN. 06901



Federation Internationale de l'Automobile
FORM OF RECOGNITION

In accordance with Appendix "J" of the International Sporting Code

I N D E X

<u>ITEM</u>	<u>NUMBERS</u>	<u>PAGES</u>
Basic Data & Photo		1
Photos		2-3
Sketches		4
Capacities & Dimensions	1-9	5
Chassis & Bodywork	20-32	6
Accessories & Upholstery	38-45	6
Wheels	50-54	6
Steering	70-82	6-7
Brakes	90-105	7
Engine	130-203	8-10
Carburetion	210-216	10
Injection	220-225	10
Engine Accessories	230-241	11
Engine & Car Performance	250-253	11
Drive Train	260-293	11-12
Optional Equipment		13-14
Variants & Evolutions, if any		

CONVERSION TABLE:

1 inch / pouce	2.54 cm	
1 foot / pied	30.479 cm	
1 square inch / pouce carre	6.452 cm ²	
1 cubic inch / pouce cube	16.387 cm ³	
1 pound (lb.) / livre	453.593 gr	
1 pint (U.S.)	.473 ltrs	.833 pt. Imp.
1 quart (U.S.)	.946 ltrs	.833 qt. Imp.
1 gallon (U.S.)	3.785 ltrs	.833 gal. Imp.
1 pint (Imp.)	.568 ltrs	1.20 pt. U.S.
1 quart (Imp.)	1.136 ltrs	1.20 qt. U.S.
1 gallon (Imp.)	4.546 ltrs	1.20 gal. U.S.



AUTOMOBILE COMPETITION COMMITTEE
FOR THE UNITED STATES, F.I.A., INC.

1453

433 MAIN ST.
STAMFORD, CONN. 06901
(203) 348-6233

Federation Internationale de l'Automobile
FORM OF RECOGNITION

In accordance with Appendix "J" of the International Sporting Code

Cylinder capacity 4482.2 cm3 273.8 in3
 Manufacturer Chrysler Corporation Model Barracuda
 Serial # Chassis Bx2xx7xxxxxxxx Manufacturer Chrysler Corporation
 Serial # Engine x273xx Manufacturer Chrysler Corporation
 Recognition valid from _____ List _____

The manufacturing of the model described in this recognition form was started on Oct. 17, 1966 and the minimum production of 1000 identical cars, in accordance with the specifications of this form, was reached on Nov. 17, 1966.

- (*) need not be answered for Group II and III cars.
- (**) only need to be answered for Group IV cars.

A 3/4 Front View Car **



The vehicle described in this form has been subject to the following amendments:

Variants
 on 19 rec # list
 on 19 rec # list
 on 19 rec # list

Normal evolution of the type
 on 19 rec # list
 on 19 rec # list
 on 19 rec # list

Stamp/Signature of
National Sporting Authority

John L. Chivers

Stamp/Signature
F.I.A.

MAKE

Plymouth

MODEL

Barracuda

FIA REC # 1453

B 3/4 rear car (**)

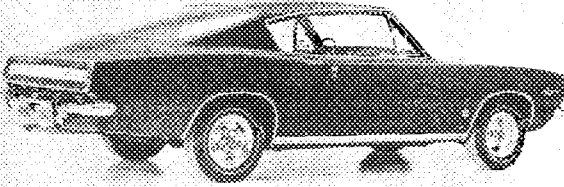

C interior-car (**)

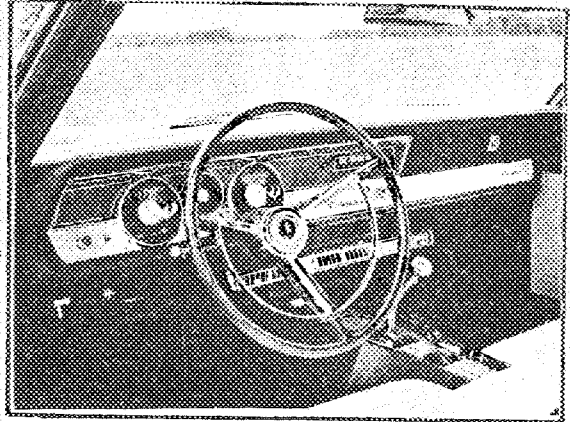

D front axle (**)

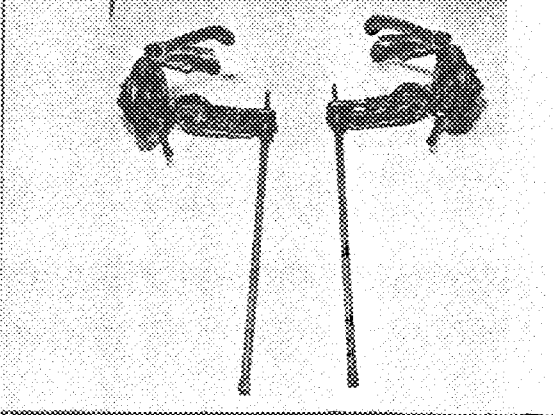

E rear axle (**)

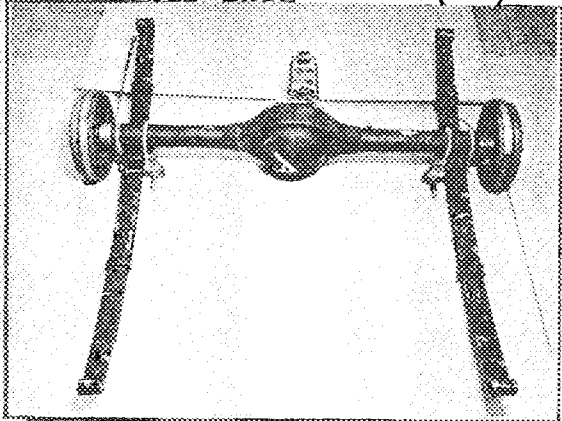

F brake, front (**)

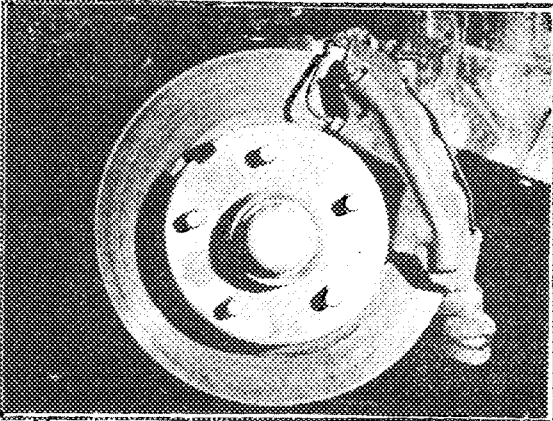

G brake, rear (**)

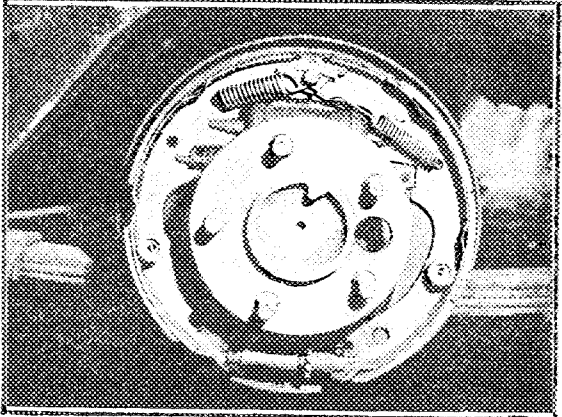

H gear box (**)

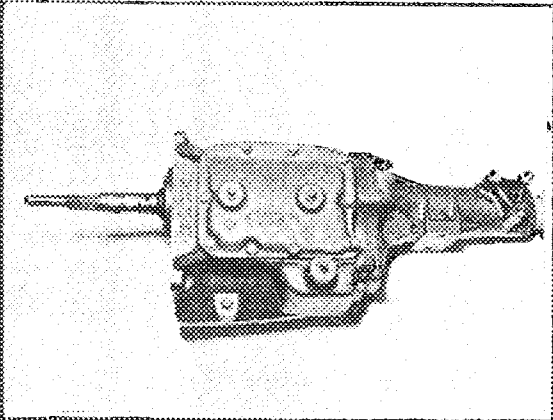

I exhaust system (*)

muffler and exhaust pipes
after exhaust manifold

STAMP

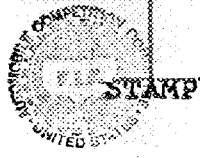

MAKE

Plymouth

MODEL

Barracuda

FIA REC #

1453

J ENGINE RIGHT (**)

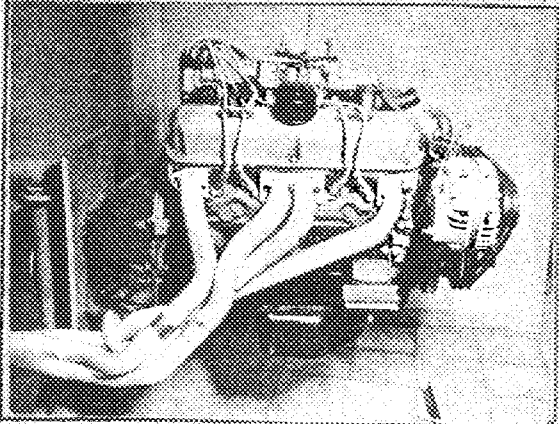

K ENGINE LEFT (**)

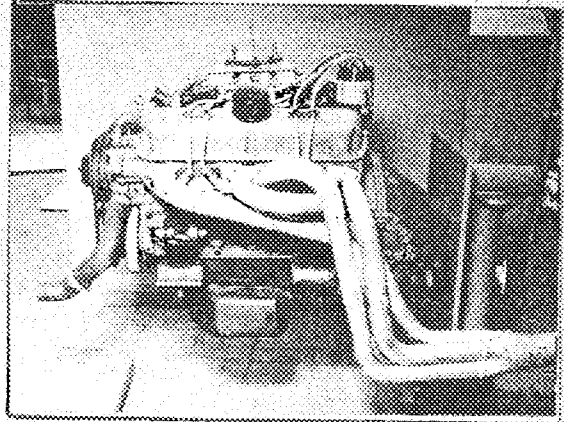

L COMBUSTION CHAMBER (*)

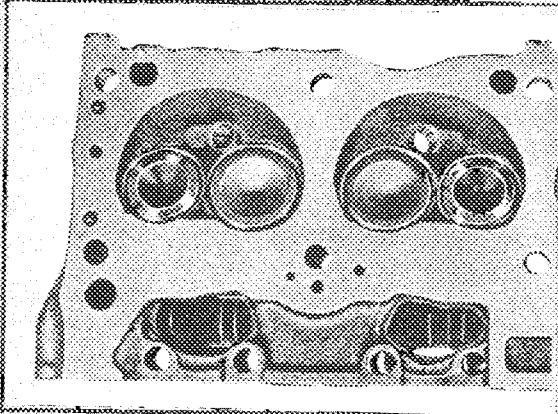

M PISTON TOP (*)

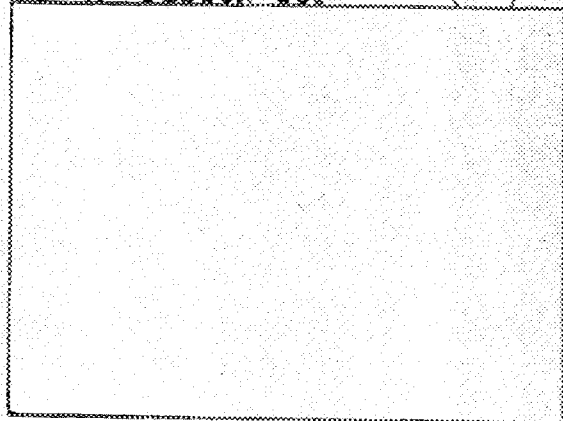

N CARBURETOR (*)

(*)

O ENGINE IN PLACE (**)

view from side of manifold

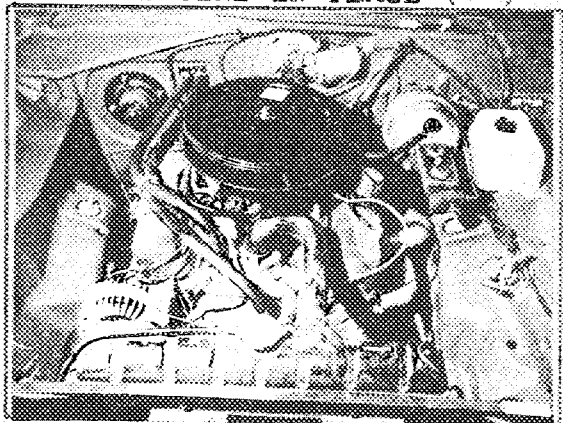

P MANIFOLD INLET

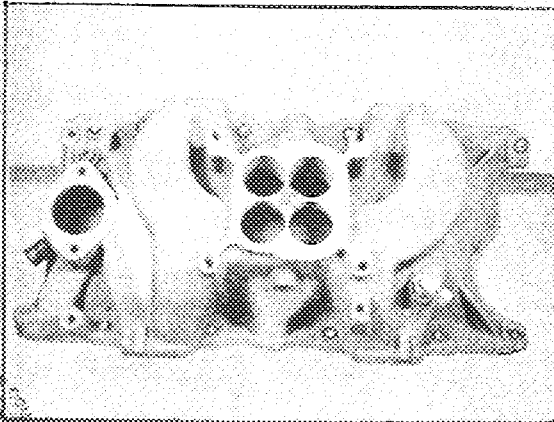

Q MANIFOLD EXHAUST

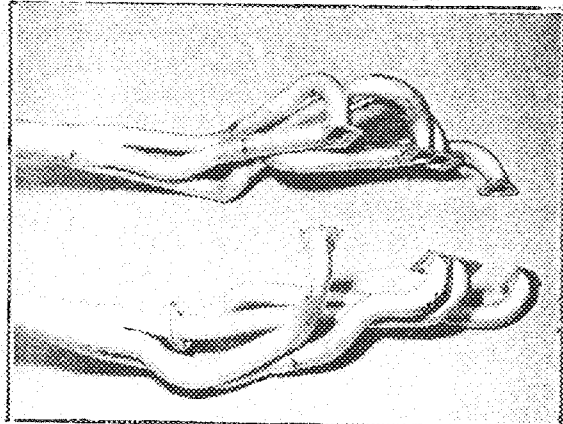

Strip out: ALL SKETCHES MUST INDICATE ACTUAL DIMENSIONS AND MANUFACTURER'S TOLERANCES.

STAMP

STAMP



ALL SKETCHES MUST INDICATE ACTUAL DIMENSIONS AND MANUFACTURER'S TOLERANCES.

*Inlet

Manifold
Porting
Cyl.
Head
Face

*Cylinder

Head
Porting
Inlet
Face

*Exhaust

Manifold
Porting
Cyl. Head
Face

*Cylinder

Head
Porting
Exhaust
Face

CAM

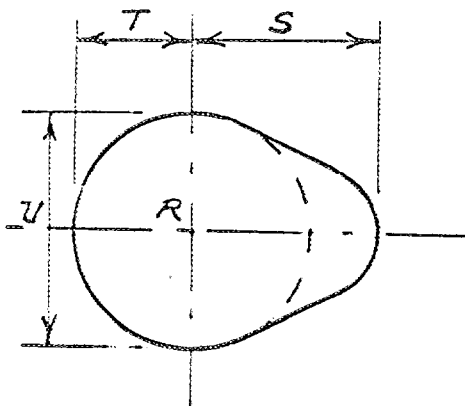

Inlet cam

S= 24.2	mm	.95in
T= 17.0	mm	.67in
U= 34.0	mm	1.34in

Exhaust cam

S= 24.2	mm	.95in
T= 17.0	mm	.67in
U= 34.0	mm	1.34in

STAMP



STAMP

MAKE Plymouth MODEL Barracuda FIA REC # 1453

IMPORTANT: Questions 1 through 9 must be answered in two measuring systems, one of which must be the metric system. See conversion table at index.

CAPACITIES & DIMENSIONS

- (**) 1. Wheelbase 2741 mm 108 in
- (**) 2. Front track 1500 mm 59.0 in +
- (**) 3. Rear track 1449 mm 57.0 in +
 + Differences in track resulting from use of optional wheel and rim sizes must be stipulated on recognition application forms.

Dimensional relationship between track (front and/or rear) and ground clearance resulting from use of optional wheel sizes shall also be stipulated and a sketch illustrating suspension reference points shall be shown below to establish the "reference chassis height." The reference chassis height dimension is to be used only when checking track and shall not affect eligibility of car in any manner.

Sketch, Ground Clearance: Dimensional Suspension & Chassis Reference Points"

Rear Track is unaffected by changes in car height

Front Track Car Height: 2.125 in

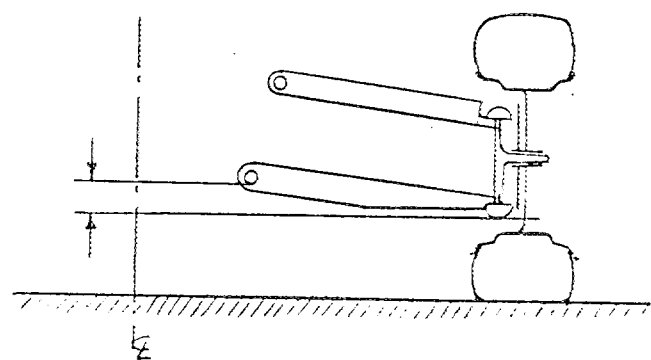

- 4. Overall length of car 489 cm 192.8 in
- 5. Overall width of car 182 cm 71.6 in
- 6. Overall height of car 136 cm 53.4 in
- 7. Capacity of fuel tank (reserve included) 68 ltrs.
18 gallons US gallons, Imp.
- 8. Seating capacity 4
- (**) 9. Weight - total weight of car with normal equipment, water, oil and spare wheel but without fuel or repair tools.

1197 kg 2640 lbs



STAMP

CHASSIS & BODYWORK - Photos A, B, C

- (**) 20. Chassis/body construction - separate/unit construction
- (**) 21. Unit construction - material/s Stamped Steel
- (**) 22. Chassis - material/s - - - separate construction - - - -
- (**) 23. Body - material/s - - - separate construction - - - -
- (**) 24. Doors - number 2 material/s Stamped Steel
- (**) 25. Hood - material/s Stamped Steel
- (**) 26. Trunk Lid - material/s Stamped Steel
- 27. Window, Rear - material/s Safety Glass
- 28. Windshield - material/s Safety Glass - Laminated
- 29. Windows, front door - material/s Safety Glass
- 30. Windows, rear door - material/s none
- 31. Windows - actuating system Rotary Crank
- 32. Window, rear quarter - material/s Safety Glass

ACCESSORIES AND UPHOLSTERY

- 38. Heating, interior - yes no
- 39. Air conditioning - yes no
- 40. Ventilation - yes no
- (*) 41. Seats, front - type of seat and upholstery - - - - -
- 42. Seats, front - weight
(complete with supports & rails out of car) 9.08 kg 20 lbs/seat
- CHECK: BENCH _____ BUCKET x CONSOLE INCLUDED Optional
- 43. Seats, rear - type of seat and upholstery Bench - Vinyl
- 44. Bumper, front - material/s stamped steel kg 6.4 lbs 14.0 Weight
- 45. Bumper, rear - material/s stamped steel kg 6.9 lbs 15.2 Weight

WHEELS

- 50. Type Stamped Steel Disc
- 51. Weight (per wheel, without tire) 9.08kg 20 lbs
- 52. Method of attachment Five Studs and Nuts
- 53. Rim, diameter 381 mm 15 in
- 54. Rim, width 178 mm 7 in

SUSPENSION

- (**) 70. Suspension, front (photo D) - type Independent
- (**) 71. Spring - type Torsion Bar
- (*) 72. Stabilizer - if fitted - - - -



STAMP

- 73. Shock absorbers - number two
- 74. Type - Telescopic
- (**) 78. Suspension, rear (photo E) - type Live Axle
- (**) 79. Spring - type Laminated Leaf
- (*) 80. Stabilizer - if fitted - - - -
- 81. Shock absorbers - number two
- 82. Type Telescopic

BRAKES (Photos E and F)

- (**) 90. Method of operation Hydraulic
- (*) 91. Power assisted (if fitted) - type - - - -
- 92. Master Cylinders - number and type One - Tandem
(indicate if duplex master cylinder) Front Rear
- 93. Cylinders - number per wheel 4 1
- 94. Cylinders - wheel bore 41.7 mm 1.64 in 22.2 mm .875 in
(indicate stepped bore dimensions if applicable)

Drum Brakes

- 95. Diameter, inside Front Rear
mm in 254 mm 10 in
- 96. Linings, length prim + second mm in 496 mm 19.5 in
- 97. Linings, width mm in 63.5 mm 2.5 in
- 98. Shoes - number per brake 31,550 2
- 99. Area, total - per brake mm² in² mm² 48.9 in²

Disc Brakes

- 100. Diameter, outside 283 mm 11.12 in mm in
- 101. Thickness of disc 20.6 mm .81 in mm in
- 102. Lining - length 122 mm 4.82 in mm in
- 103. Lining - width 46.7 mm 1.84 in mm in
- 104. Pads - number per brake 2
- 105. Area, total - per brake 11,490 mm² 17.7 in² mm² in²

STAMP



STAMP

MAKE Plymouth MODEL Barracuda FIA REC # 1453

ENGINE (Photos J and K)

- (**) 130. Cycle two four Wankel
- (**) 131. Cylinders - number Eight
- (**) 132. Cylinders - arrangement Vee Wankel - # of elements and basic dimensions
- (**) 133. Bore 92.1 mm 3.63 in
- (**) 134. Stroke 84.1 mm 3.31 in
- (**) 135. Cylinders - capacity 560.3 cm3 34.23 in3
- (**) 136. Cylinders, total capacity 4482.2 cm3 273.8 in3
- (**) 137. Cylinder Block - material/s Cast Iron
- (**) 138. Sleeves - material/s (if fitted) None
- (*) 139. Head, cylinder - material/s Cast Iron number fitted Two
- (**) 140. Port, inlet - number Four/Head
- (**) 141. Port, exhaust - number Four/Head
- (*) 142. Compression - ratio - - - -
- (*) 143. Combustion chamber - volume - cm3 - - - - in3
- (*) 144. Piston - material/s - - - -
- (*) 145. Rings - number - - - -
- (*) 146. Distance from gudgeon pin centre line to highest point of piston crown - - - - mm - - - - in
- (**) 147. Crankshaft - cast-forged-mach from solid
- (*) 148. Crankshaft - type - integral - sectioned - # of sections
- (**) 149. Crankshaft, main bearings - number Five
- (**) 150. Bearing cap - material/s Cast Iron
- 151. Lubrication - system - dry sump/oil in sump
- 152. Lubricant - capacity 5.68 ltrs 12 pts 6 qts US
- (*) 153. Cooler, oil - yes no
- 154. Cooling - method water
- 155. Cooling - capacity of system 17.99 ltrs 38pts 19qts US

STAMP

STAMP



- (*) 156. Fan, cooling (if fitted) - diameter - - - cm - - - in
- (*) 157. Fan, cooling - number of blades - - - material/s - - -

BEARINGS

- (**) 158. Crankshaft, main - type ^{Babbitt} Steel diameter 63.5 mm 2.5 in
- (**) 159. Connecting rod, big end - type ^{Bi-Metal} grid diameter 54.1 mm 2.13 in

WEIGHTS

- (*) 160. Flywheel (clean) - - - - kg - - - - lbs
- (*) 161. Flywheel with clutch (all rotating parts) - - kg - - lbs
- (*) 162. Crankshaft - - - kg - - - lbs
- 163. Connecting Rod .816 kg 1.8 lbs
- (*) 164. Piston with rings & pin - - - kg - - - lbs

FOUR CYCLE ENGINES

- (**) 170. Camshafts - number One material/s Hardenable Cast Iron
- (*) 171. Camshaft - location in cylinder block
- (**) 172. Camshaft Drive, type Chain and sprocket
- (**) 173. Valve operation - type Push Rod

INLET (See Photo P) (for addtl info re 2 stroke engines and super charged, see page 15)

- 180. Inlet manifold - materials Aluminum
- 181. Valves (overall) - diameter 49.0 mm 1.93 in
- (*) 182. Valve lift - maximum - - - - mm - - - - in
- 183. Springs, valve - number One/Valve
- 184. Spring - type Coil
- (**) 185. Valves, per cylinder - number Two
- (*) 186. Tappet - clearance for checking timing (cold) - - mm - - in
- (*) 187. Valves - open at (with tolerance for tappet clearance indicated) - - - -
- (*) 188. Valves - close at (with tolerance for tappet clearance indicated) - - - -
- (*) 189. Air filter - type - - - -

STAMP



STAMP

EXHAUST (See Photo Q)

- 195. Manifold, exhaust - material/s Steel
- 196. Valves (overall) - diameter 43.7 mm 1.72 in
- 197. Valve, lift - maximum 10.8 mm .425 in
- 198. Valve Springs/valve - number One/Valve
- 199. Springs - type Coil
- (**) 200. Valves - number per cylinder Two
- (*) 201. Tappet - clearance for checking timing (cold)
- - - mm - - - in
- (*) 202. Valves - open at (with tolerance for tappet
clearance indicated) - - -
- (*) 203. Valves - close at (with tolerance for tappet
clearance indicated) - - -

CARBURETION (See Photo N)

- 210. Carburetors, fitted - number One
- 211. Type Downdraft
- (*) 212. Make - - - -
- (*) 213. Model - - - -
- 214. Carburetors - number of mixture passages four
- (*) 215. Carburetor - flange hole diameter of exit port
- - - mm - - - in
- 216. Venturi - throat diameter+

	<u>Primaries</u>	
35.0 mm	1.38	in
	<u>secondaries</u>	
36.6	1.44	

INJECTION

- 220. Pump - make none
- 221. Plungers - number
- (*) 222. Pump - model
- 223. Injectors - location
- 224. Injectors - total number
- (*) 225. Inlet pipe - minimum diameter mm in

+ For variable throat type carburetors, indicate minimum lift of shutter mechanism such as pistons in S.U.



STAMP

MAKE Plymouth MODEL Barracuda FIA REC # 1453

ENGINE ACCESSORIES

- (*) 230. Pump, fuel - mechanical and/or electrical - - -
- 231. Number fitted One
- 232. Ignition system - type Coil
- 233. Distributors - number One
- 234. Coils, ignition - number One
- 235. Spark plugs - number per cylinder One
- 236. Generator (or Alternator) - number fitted One
- 237. Drive - method Belt
- 238. Voltage, generator - volts Twelve
- 239. Battery - number One
- 240. Location In Trunk
- 241. Voltage - volts 12 amp hrs 38

ENGINE & CAR PERFORMANCE as declared by mfr. in catalogue

- (*) 250. Horsepower - maximum engine output - - - at - - - rpm
(indicate SAE or DIN)
- (*) 251. RPM - maximum - - - output at that figure - - -
- (*) 252. Torque - maximum - - - - at - - - rpm
- (*) 253. Speed - maximum - - - - km/hour - - - - miles/hour

DRIVE TRAIN

Clutch

- 260. Type Dry Plate
- 261. Plates - number of driven One
- 262. Plates - diameter 26.65 cm 10.5 in
- 263. Linings - diameter - inside 16.5 cm 6.5 in
Linings - diameter - outside 26.65 cm 10.5 in
- 264. Method of operation Foot Operated Mechanical Linkage

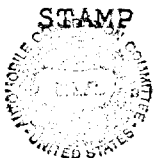

STAMP

Gear Box (Photo H)

- (**) 270. Manual type - make Synchronesh - Chrysler
- (**) 271. Ratios, forward - number Four
- 272. Ratios, forward - number synchronized Four
- 273. Gear-Shift - location Floor optional - - - -
- (**) 274. Automatic - make Chrysler type Planetary Gear Train w/Torque Converter
- (**) 275. Ratios, forward - number Three
- 276. Gear-Shift - location Floor

277.	Manual		Automatic		Alternative manual/automatic			
	Ratio	# Teeth	Ratio	# Teeth	Ratio	# Teeth	Ratio	# Teeth
1	2.66	$\frac{24}{31} \times \frac{17}{35}$	2.45	annulus 62	2.65	$\frac{21}{27} \times \frac{16}{33}$		
2	1.91	$\frac{24}{31} \times \frac{23}{34}$	1.45	sun 28	1.64	$\frac{21}{27} \times \frac{22}{28}$		
3	1.39	$\frac{24}{31} \times \frac{27}{29}$	1.00	planet 17	1.19	$\frac{21}{27} \times \frac{29}{26}$		
4	1.00	- - -			1.00	- - -		
5								
6								
reverse	2.58	$\frac{24}{31} \times \frac{17}{22} \times \frac{22}{34}$	2.20		2.57	$\frac{21}{27} \times \frac{17}{22} \times \frac{22}{34}$		

- 278. Overdrive - type None
- 279. Forward gears on which overdrive can be selected - - - -
- 280. Overdrive - ratio - - - -

FINAL DRIVE

- (**) 290. Type Hotchkiss
- (**) 291. Differential - type Semi-Floating
- (**) 292. Limited Slip Differential (if fitted) - type \neq Friction
- 293. Ratio 3.23 3.55 3.91 4.10
- Teeth - number 13/42 11/39 11/43 10/41
- (\neq) Specify friction or positive locking type



STAMP

MAKE Plymouth

MODEL Barracuda

FIA REC # 1453

IMPORTANT

The conformity of the car with the following items of the present recognition form is to be disregarded during the technical inspection when the vehicle has been entered in Group II (Touring Cars) or III (Grand Touring Cars):

41, 72, 80, 91, 142, 143, 144, 145, 146, 153, 156, 157, 160, 161, 162, 163, 164, 182, 186, 187, 188, 189, 201, 202, 203, 212, 213, 215, 216, 222, 225, 230, 250, 251, 252, 253, 255, photos I, M, N & items on page 5 as indicated.

During the technical inspection of cars entered in Group IV (Sports Cars) only the following items of the present recognition form are to be taken into consideration:

1, 2, 3, 9, 20, 21, 22, 23, 24, 25, 26, 70, 71, 78, 79, 90, 130, 131, 132, 133, 134, 135, 136, 137, 138, 139, 140, 141, 147, 148, 149, 150, 158, 159, 170, 171, 172, 173, 185, 200, 270, 271, 274, 275, 290, 291, 292 & photos A, B, D, E, F, G, H, J, K, O.

Optional equipment affecting preceding information:

CATALOGUE PART NUMBER MUST BE GIVEN

50. Wheels - Stamped Steel Disc - 14 in. dia. x 5.5 in. wide
356 mm 139.8 mm
Part Number: 2298523

7. Gas Tank - Aux. 19 Gallons U.S. 72 ltrs.
Part Number: 2836136

STAMP



STAMP

MAKE Plymouth - MODEL Barracuda FIA REC # 1453

Optional Equipment - CATALOGUE PART NUMBER MUST BE GIVEN

The Barracuda is also available with the optional roofline shown in the photographs below. Car is otherwise identical in all respects to the Plymouth Barracuda Fastback Model.

Serial #: Model Bx23x7xxxxxxx

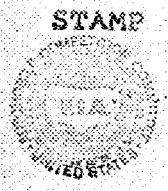
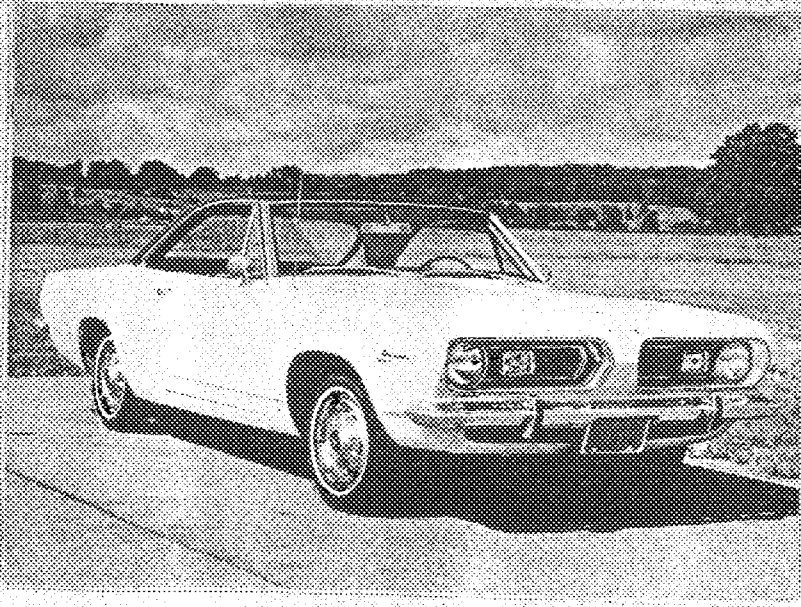

STAMP