



FEDERATION INTERNATIONALE
DU SPORT AUTOMOBILE

Homologation No

C2-0013

EC2-009-93

FICHE D'HOMOLOGATION POUR MOTEUR DE VOITURE DE TOURISME (Classe II)
HOMOLOGATION FORM FOR TOURING CAR ENGINE (Classe II)

1993年 8月31日

Constructeur / Manufacturer: HONDA MOTOR CO., LTD Modèle et type / Model and type: B18B ENGINE

Homologation valable à partir du / Homologation valid as from: 01 OCT. 1993

MOTEUR (version standard)
ENGINE (standard version)

Cycle: 4-Stroke (OTTO)

Nombre et disposition des cylindres / Number and layout of the cylinders: 4-in line

Mode de refroidissement / Cooling system: Liquid

Cylindrée: Unitaire Totale
Cylinder capacity: Unitary Total
458.5 cm³ 1,834.0 cm³

Matériau du bloc cylindres / Cylinder block material: Aluminum-alloy

Vilebrequin :
Crankshaft :

Matériau / Material: Steel

Type de paliers / Type of bearings: Plain

Bielles :
Connecting rods :

Matériau / Material: Steel

Arbres à cames :
Camshafts :

Nombre / Number: 2

Emplacement / Location: Top (DOHC)



Marque
Make HONDA

Modèle
Model B18B ENGINE

Homologation No

EC2-0013

EC2-009-93

Culasse :
Cylinder head :

Nombre
Number 1

Système de commande des soupapes
Type of valve operation Rocker arm

Angle entre axe de la soupape d'admission et axe de la soupape d'échappement
Angle between inlet valve axle and exhaust valve axle 52°

Admission : Nombre de soupapes par cylindre
Inlet : Number of valves per cylinder 2

Echappement : Nombre de soupapes par cylindre
Exhaust : Number of valves per cylinder 2

Système de refroidissement : Mode de refroidissement
Cooling system : Cooling type



PHOTOS

Profil droit du moteur complet déposé
Right hand view of complete dismantled engine

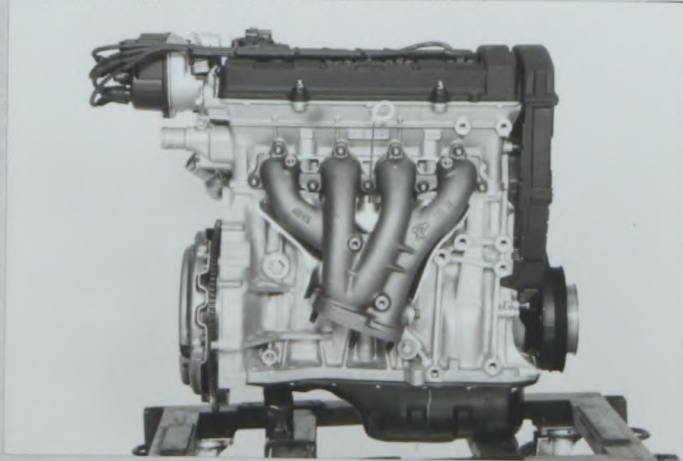

Profil gauche du moteur complet déposé
Left hand view of complete dismantled engine

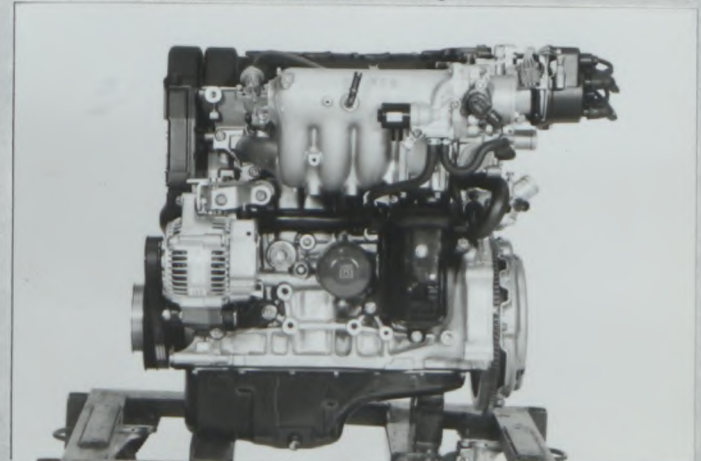

Culasse nue vue de dessus
Bare cylinder head seen from above

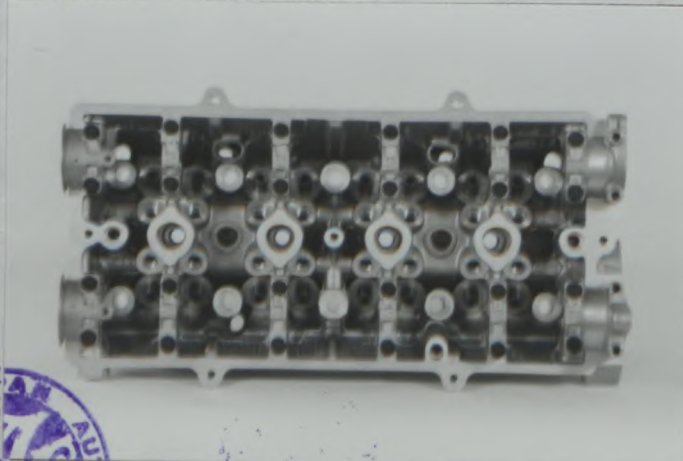

Culasse nue vue de dessous
Bare cylinder head seen from below

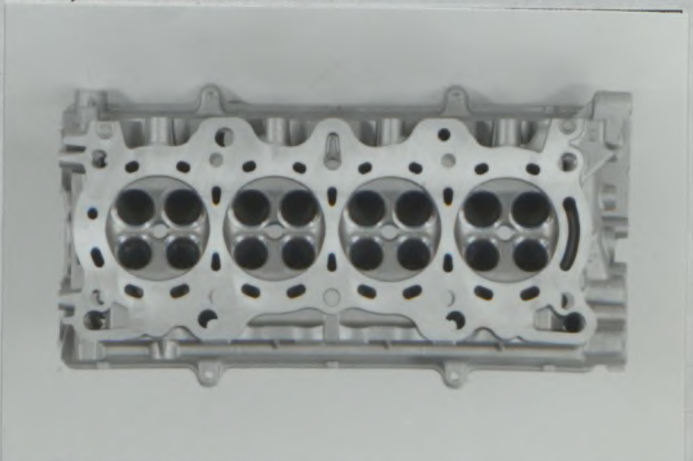

Marque
Make

HONDA

Modèle
Model

B18B ENGINE

Homologation No

C2-0013

EC2-009-93

Profil droit de culasse nue
Right hand view of bare cylinder head

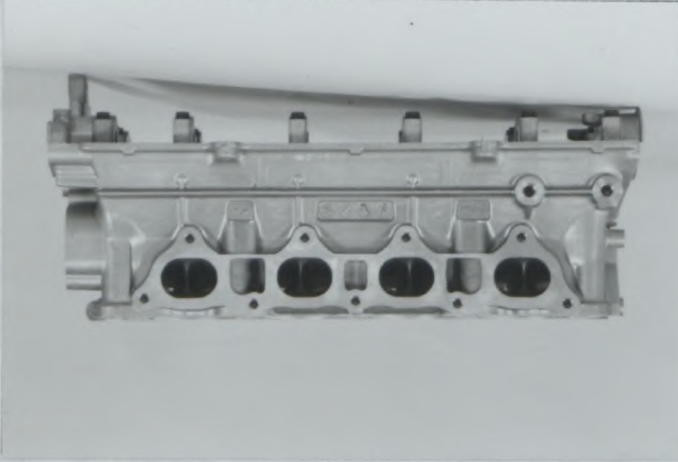

Profil gauche de culasse nue
Left hand view of bare cylinder head

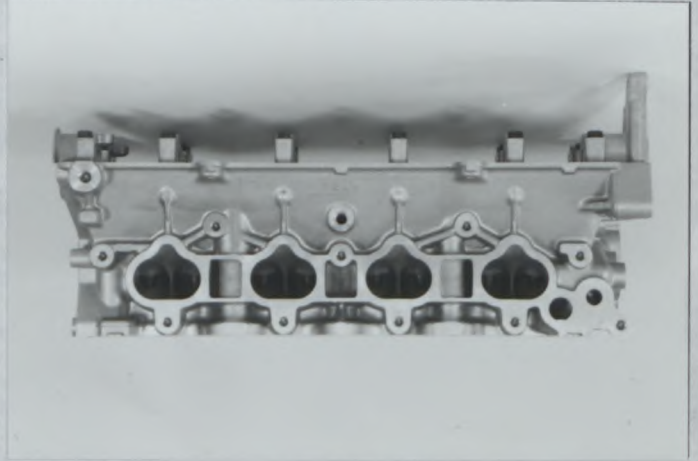

Bloc nu vu de dessus
Bare block seen from above

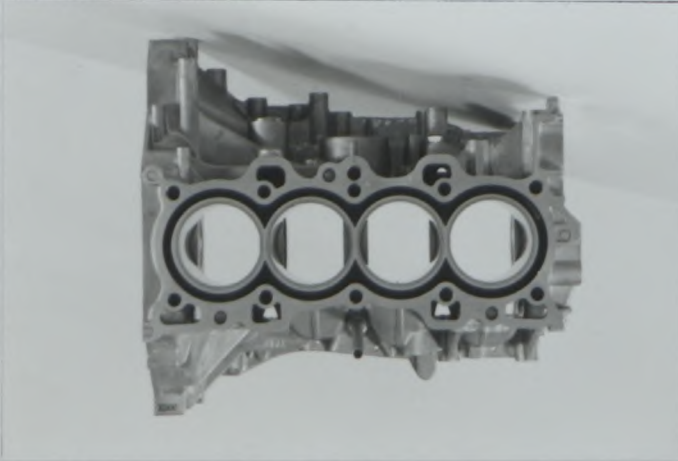

Bloc nu vu de dessous
Bare block seen from below

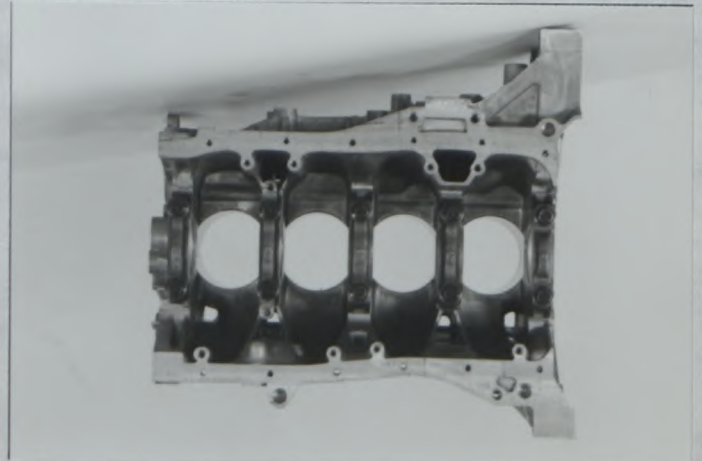

Profil droit du bloc nu
Right hand view of bare block

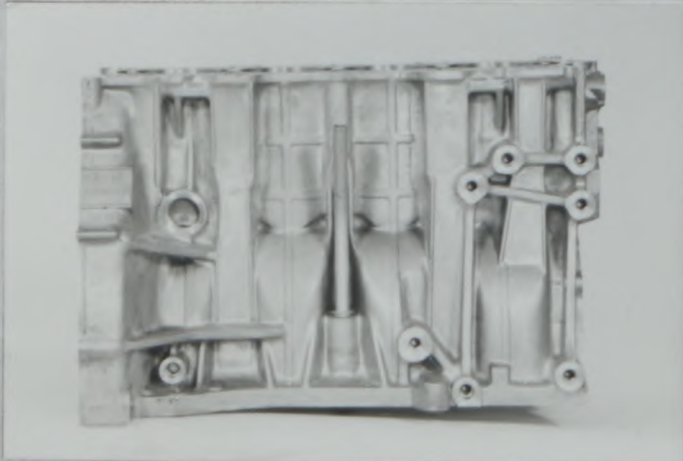

Profil gauche du bloc nu
Left hand view of bare block

