



# FEDERATION INTERNATIONALE DU SPORT AUTOMOBILE

Homologation N°

B-262

Groupe **A/B**  
GroupFICHE D'HOMOLOGATION CONFORME A L'ANNEXE J DU CODE SPORTIF INTERNATIONAL  
HOMOLOGATION FORM IN ACCORDANCE WITH APPENDIX J OF THE INTERNATIONAL SPORTING CODEHomologation valable à partir du **01 AVR. 1984** en groupe  
Homologation valid as from \_\_\_\_\_ in group B

Photo A



Photo B



## 1. DEFINITIONS / DEFINITIONS

101. Constructeur  
Manufacturer PEUGEOT
102. Dénomination(s) commerciale(s) — Modèle et type  
Commercial name(s) — Type and model 205 TURBO 16
103. Cylindrée totale  
Cylinder capacity (1774,6 x 1,4) 2484,4 cm<sup>3</sup>
104. Mode de construction  
Type of car construction
- séparée, matériau du châssis  
separate, material of chassis Tôle Acier
- monocoque  
unitary construction
105. Nombre de volumes  
Number of volumes 2
106. Nombre de places  
Number of places 2



Marque PEUGEOT Modèle 205 T 16 N° Homol. **B-262**

2. DIMENSIONS, POIDS / DIMENSIONS, WEIGHT

202. Longueur hors-tout Overall length 3 825 mm ± 1%
203. Largeur hors-tout Overall width 1,674 mm ± 1% Endroit de la mesure Where measured Axe AV.
204. Largeur de la carrosserie: Width of bodywork:  
a) A la hauteur de l'axe AV At front axle 1 674 mm ± 1%  
b) A la hauteur de l'axe AR At rear axle 1 664 mm ± 1%
206. Empattement: a) Droit Wheelbase: Right 2 540 mm ± 1% b) Gauche: Left: 2 540 mm ± 1%
209. Porte-à-faux: a) AV: Overhang: Front: 671 mm ± 1% b) AR: Rear: 614 mm ± 1%
210. Distance «G» (volant — paroi de séparation AR) Distance «G» (steering wheel — rear bulkhead) 787 mm ± 1%

3. MOTEUR / ENGINE: (En cas de moteur rotatif, voir Article 335 sur fiche complémentaire).  
(In case of rotative engine, see Article 335 on complementary form).

301. Emplacement et position du moteur: Location and position of the engine: Transversal AR incliné à 20° vers l'AR.

303. Cycle 4 temps

304. Suralimentation oui/non; type Supercharging yes/no; type Turbo compresseur entraîné par les gaz d'échappement.  
(En cas de suralimentation, voir également l'Article 334 sur fiche complémentaire)  
(In case of supercharging, see also Article 334 on complementary form)

305. Nombre et disposition des cylindres Number and layout of the cylinders 4 en ligne

306. Mode de refroidissement Cooling system liquide

307. Cylindrée: a) Unitaire 443,75 cm³ b) Totale  
Cylinder capacity: a) Unitary 443,75 cm³ b) Total (1774,6 x 1,4) 2484,4 cm³  
c) Totale maximum autorisée\*: (1785,39 x 1,4) 2499,54 cm³  
c) Maximum total allowed\*: (1785,39 x 1,4) 2499,54 cm³  
\*(Cette indication n'est pas à considérer en Gr. N)  
\*(This indication is not to be considered in Gr. N)



Marque PEUGEOT Modèle 205 T 16 N° Homol. **B-262**  
Make Model

312. Matériau du bloc-cylindres ALLIAGE ALUMINIUM  
Cylinder block material

313. Chemises: a) oui/XXXX c) Type: HUMIDE  
Sleeves: yes/no Type:

314. Alésage Bore 83 mm

315. Alésage maximum autorisé (Cette indication n'est pas à considérer en Gr N)  
Maximum bore allowed 83,25 mm (This indication is not to be considered in Gr N)

316. Course Stroke 82 mm

318. Bielle: a) Matériau ACIER b) Type de la tête de bielle 2 PARTIES  
Connecting rod: Material Big end type

c) Diamètre intérieur de la tête de bielle (sans coussinets): 53,7 mm ± 0,1%  
Interior diameter of the big end (without bearings):

d) Longueur entre axes: 140 mm (± 0,1 mm) e) Poids minimum: 660 g  
Length between the axes: Minimum weight:

319. Vilebrequin: a) Type de construction MONOBLOC  
Crankshaft: Type of manufacture

b) Matériau ACIER  
Material

c)  coulé  estampé  
 moulded  stamped

d) Nombre de paliers 5  
Number of bearings

e) Type de paliers LISSE  
Type of bearings

f) Diamètre des paliers 60 mm ± 0,2%  
Diameter of bearings

g) Matériau des chapeaux des paliers FONTE  
Bearing caps material

h) Poids minimum du vilebrequin nu 17600 g  
Minimum weight of the bare crankshaft

320. Voilant moteur: a) Matériau FONTE  
Flywheel: Material

b) Poids minimum avec couronne de démarreur 5600 g  
Minimum weight of the flywheel with starter ring

321. Culasse: a) Nombre de culasses 1 b) Matériau ALLIAGE D'ALUMINIUM  
Cylinderhead: Number of cylinderheads Material

323. Alimentation par carburateur(s): a) Nombre de carburateurs /  
Fuel feed by carburettor(s): Number of carburators

b) Type / c) Marque et modèle /  
Type Make and model



Marque PEUGEOT Modèle 205 T 16 N° Homol. B-262  
 Make \_\_\_\_\_ Model \_\_\_\_\_

- d) Nombre de passages de gaz par carburateur  
 Number of mixture passages per carburettor \_\_\_\_\_ / \_\_\_\_\_
- e) Diamètre maximum de la tubulure de gaz à la sortie du carburateur  
 Maximum diameter of the flange hole of the carburettor exit port \_\_\_\_\_ / \_\_\_\_\_ mm
- f) Diamètre du diffuseur au point d'étranglement maximum  
 Diameter of the venturi at the narrowest point \_\_\_\_\_ / \_\_\_\_\_ mm

**324. Alimentation par injection:**

**Fuel feed by injection:**

a) Marque: BOSCH  
 Manufacturer: \_\_\_\_\_

b) Modèle du système d'injection: K JETRONIK  
 Model of injection system: \_\_\_\_\_

c) Mode de dosage du carburant:  mécanique  électronique  hydraulique  
 Kind of fuel measurement:  mechanical  electronical  hydraulic

- c1) Plongeur  oui / non  Piston pump  yes / no
- c2) Mesure du volume d'air  oui / non  Measurement of air volume  yes / no
- c3) Mesure de la masse d'air  oui / non  Measurement of air mass  yes / no
- c4) Mesure de la vitesse de l'air  oui / non  Measurement of air speed  yes / no
- c5) Mesure de la pression d'air  oui / non  Measurement of air pressure  yes / no
- Quelle est la pression de réglage?  
 Which pressure is taken for measurement? 3,6 bars

d) Dimensions effectives du point de mesure au(x) papillon(s) ou au(x) tiroir(s) d'étranglement  
 Effective dimensions of measure position in the throttle area 4 conduits Ø 32,2 mm

e) Nombre des sorties effectives de carburant  
 Number of effective fuel outlets 4

f) Position des soupapes d'injection:  Canal d'admission  Culasse  
 Position of injection valves:  Inlet manifold  Cylinderhead

g) Parties du système d'injection servant au dosage du carburant  
 Statement of fuel measuring parts of injection system Débitmètre - doseur calculateur

- 325. Arbre à cames:** a) Nombre 2 b) Emplacement en tête  
**Camshaft:** Number \_\_\_\_\_ Location \_\_\_\_\_
- c) Système d'entraînement courroie d) Nombre de paliers par arbre 5  
 Driving system \_\_\_\_\_ Number of bearings for each shaft \_\_\_\_\_
- f) Système de commande des soupapes poussoir

**326. Distribution:** e) Levée maximum des soupapes Admission Echappement  
**Timing:** Maximum valve lift Inlet 9,15 mm Exhaust 9,15 mm

avec jeu de with clearance 0,5 mm 0,5 mm

- 327. Admission:** a) Matériau du collecteur ALLIAGE ALUMINIUM  
**Inlet:** Material of the manifold \_\_\_\_\_
- b) Nombre d'éléments du collecteur 1 c) Nombre de soupapes par cylindre 2  
 Number of manifold elements \_\_\_\_\_ Number of valves per cylinder \_\_\_\_\_
- d) Diamètre maximum des soupapes 33,4 mm e) Diamètre de la tige de soupape 6,5 mm  
 Maximum diameter of the valves \_\_\_\_\_ Diameter of the valve stem \_\_\_\_\_
- f) Longueur de la soupape 117,15 mm g) Type des ressorts de soupape HELICOIDAL  
 Length of the valve \_\_\_\_\_ Type of valve springs \_\_\_\_\_



Marque Make PEUGEOT Modèle Model 205 T 16 N° Homol. B-262

328. Echappement: a) Matériau du collecteur ACIER
Exhaust: Material of the manifold
b) Nombre d'éléments du collecteur 1
Number of manifold elements
c) Diamètre maximum des soupapes 30 mm
Maximum diameter of the valves
d) Nombre de soupapes par cylindre 2
Number of valves per cylinder
e) Diamètre de la tige de soupape 6,5 mm
Diameter of the valve stem
f) Longueur de la soupape 117,2 mm
Length of the valve
g) Type des ressorts de soupape HELICOIDAL
Type of valve springs

330. Système d'allumage: a) Type ELECTRONIQUE - BATTERIE - BOBINE
Ignition system: Type
b) Nombre de bougies par cylindre 1
Number of plugs per cylinder
c) Nombre de distributeurs /
Number of distributors

333. Système de lubrification: a) Type CARTER HUMIDE
Lubrification system: Type
b) Nombre de pompes à huile 1
Number of oil pumps

4. CIRCUIT DE CARBURANT / FUEL CIRCUIT

401. Réservoir: a) Nombre 2
Fuel tank: Number
b) Emplacement SOUS LES SIEGES
Location
c) Matériau POLYETHYLENE
Material
d) Capacité maximum 110 LITRES
Maximum capacity

5. EQUIPEMENT ELECTRIQUE / ELECTRICAL EQUIPEMENT

501. Batterie(s): a) Nombre 1
Battery(les): Number

6. TRANSMISSION / DRIVE

601. Roues motrices:
Driving wheels: [XX] avant front [XX] arrière rear

602. Embrayage: b) Système de commande HYDRAULIQUE
Clutch: Drive system
c) Nombre de disques 1
Number of plates



Marque PEUGEOT Modèle 205 T 16 N° Homol. B-262  
 Make PEUGEOT Model 205 T 16

603. Boîte de vitesses: a) Emplacement  
 Gear-box: Location TRANSVERSALE AR

b) Marque «manuelle» PEUGEOT c) Marque «automatique»  
 «Manual» make PEUGEOT «Automatic» make

d) Emplacement de la commande  
 Location of the gear lever CENTRALE AU PLANCHER

e) Rapports  
 Ratios

	Manuelle / Manual			Automatique / Automatic			B.V. suppl. / Additional G.B.		
	rappports ratio	nombre de dents / number of teeth	synchro.	rappports ratio	nombre de dents / number of teeth	synchro.	rappports ratio	nombre de dents / number of teeth	synchro.
1	2,923	38/13	XX				2,923	38/13	x
2	1,944	35/18	XX				1,944	35/18	x
3	1,321	37/28	XX				1,407	38/27	x
4	0,969	32/33	XX				1,129	35/31	x
5	0,756	28/37	XX				0,969	32/33	x
AR/R	0,143	41/22/13					0,143	41/22/13	
Constante									
Constant.									

f) Grille de vitesse  
 Gear change gate

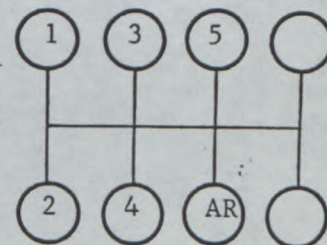
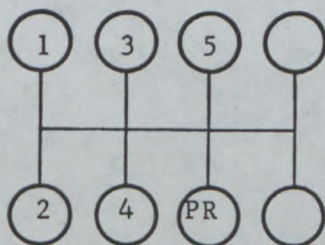

604. Surmultiplication: a) Type  
 Overdrive: Type /

b) Rapport Ratio / c) Nombre de dents Number of teeth /

d) Utilisable avec les vitesses suivantes Usable with the following gears /



Marque PEUGEOT  
Make

Modèle 205 T 16  
Model

N° Homol. B-262

605. Couple final:

Final drive:

- a) Type du couple final  
Type of final drive  
b) Rapport  
Ratio  
c) Nombre de dents  
Teeth number  
d) Type de limitation de  
différentiel (si prévu)  
Type of differential  
limitation (if provided)

AV / Front	AR / Rear
<u>Couple conique hypoïde</u>	<u>couple conique hypoïde</u>
<u>3,888</u>	<u>3,888</u>
<u>35/9</u>	<u>35/9</u>
<u>A glissement limité</u>	<u>A glissement limité</u>

e) Rapport de la boîte de transfert 26/23 1,130  
Ratio of the transfer box

606. Type de l'arbre de transmission Jointts homocinétiques  
Type of the transmission shaft

7. SUSPENSION / SUSPENSION

701. Type de suspension: a) AV / Front Double triangles superposés  
Type of suspension: b) AR / rear Double triangles superposés

702. Ressorts hélicoïdaux: AV: oui/~~non~~  
Helicoidal springs: Front: yes/~~no~~ AR: oui/~~non~~  
Rear: yes/~~no~~

703. Ressorts à lames: AV: ~~oui~~/non  
Leaf springs: Front: ~~yes~~/no AR: ~~oui~~/non  
Rear: ~~yes~~/no

704. Barre de torsion: AV: ~~oui~~/non  
Torsion bar: Front: ~~yes~~/no AR: ~~oui~~/non  
Rear: ~~yes~~/no

705. Autre type de suspension: Voir photo/dessin en page 15  
Other type of suspension: See photo or drawing on page 15



Marque PEUGEOT  
 Make \_\_\_\_\_

Modèle 205 T 16  
 Model \_\_\_\_\_

N° Homol. B-262  
 \_\_\_\_\_

**707. Amortisseurs:**

**Shock Absorbers:**

- a) Nombre par roue  
 Number per wheel  
 b) Type  
 Type  
 c) Principe de fonctionnement  
 Working principle

Avant / Front	Arrière / Rear
1	1
TELESCOPIQUE	TELESCOPIQUE
HYDRAULIQUE	HYDRAULIQUE

**8. TRAIN ROULANT / RUNNING GEAR:**

801. Roues: a) Diamètre AV 15,354 / 390 mm AR 15,354 / 390 mm  
 Wheels: Diameter Front \_\_\_\_\_ mm Rear \_\_\_\_\_ mm

803. Freins: a) Système de freinage HYDRAULIQUE  
 Brakes: Braking system \_\_\_\_\_  
 b) Nombre de maître-cylindres TANDEM b1) Alésage ∅ 22 et 22 mm  
 Number of master cylinders \_\_\_\_\_ Bore \_\_\_\_\_ mm  
 c) Servo-frein oui/yes c1) Marque et type Têtes à dépression  
 Power assisted brakes yes/nox Make and type \_\_\_\_\_  
 d) Régulateur de freinage oui/yes d1) Emplacement AV gauche  
 Braking adjuster yes/nox Location \_\_\_\_\_

e) Nombre de cylindres par roue:  
 Number of cylinders per wheel:

e1) Alésage  
 Bore

f) Freins à tambours:  
 Drum brakes:

f1) Diamètre intérieur  
 Interior diameter

f2) Nombre de mâchoires par roue.  
 Number of shoes per wheel

f3) Surface de freinage  
 Braking surface

f4) Largeur des garnitures  
 Width of the shoes

g) Freins à disques:  
 Disc brakes:

g1) Nombres de sabots par roue  
 Number of pads per wheel

g2) Nombre d'étriers par roue  
 Number of calipers per wheel

Avant / Front	Arrière / Rear
1	1
54 mm	50 mm
_____ mm (± 1,5 mm)	_____ mm (± 1,5 mm)
_____ cm <sup>2</sup>	_____ cm <sup>2</sup>
_____ mm	_____ mm
2	2
1	1





Marque / Make PEUGEOT

Modèle / Model 205 T 16

N° Homol. B-262

	AV / Front	AR / Rear
g3) Matériau des étriers Caliper material	<u>Fonte + Alu</u>	<u>Fonte + Alu</u>
g4) Epaisseur maximale du disque Maximum disc thickness	<u>20,1</u> mm	<u>20,1</u> mm
g5) Diamètre extérieur du disque Exterior diameter of the disc	<u>273</u> mm (± 1 mm)	<u>273</u> mm (± 1 mm)
g6) Diamètre extérieur de frottement des sabots Exterior diameter of the shoe's rubbing surface	<u>272,4</u> mm	<u>272,4</u> mm
g7) Diamètre intérieur de frottement des sabots Interior diameter of the shoe's rubbing surface	<u>184,8</u> mm	<u>184,8</u> mm
g8) Longueur hors-tout des sabots Overall length of the shoes	<u>105</u> mm	<u>105</u> mm
g9) Disques ventilés Ventilated disc	<u>oui/non</u> <u>yes/no</u>	<u>oui/non</u> <u>yes/no</u>
g10) Surface de freinage par roue Braking surface per wheel	<u>629,11</u> cm <sup>2</sup>	<u>629,11</u> cm <sup>2</sup>

h) Frein de stationnement:  
Parking brake:  
h2) Emplacement de la commande  
Location of the lever AU PLANCHER

h1) Système de commande  
Command system CABLE  
h3) Effet sur roues  
On which wheels  Front  Rear AR

804. Direction: a) Type  
Steering: Type CREMAILLERE  
b) Rapport  
Ratio 19,2/1

c) Servo-assistance  oui/non  
Power assisted  yes/no

### 9. CARROSSERIE / BODYWORK

901. Intérieur: a) Ventilation oui/non  
Interior: Ventilation yes/no  
f) Toit ouvrant optionnel oui/non  
Sun roof optional yes/no  
f2) Système de commande  
Command system /

b) Chauffage oui/non  
Heating yes/no  
f1) Type /

g) Système d'ouverture des vitres latérales:  
Opening system for the side windows:  
AV/Front: Lève vitre mécanique  
AR/Rear: /

902. Extérieur: a) Nombre de portes 2  
Exterior: Number of doors  
c) Matériau des portières:  
Door material:

b) Hayon AR oui/non  
Rear tailgate yes/no  
AV/Front: Tôle acier  
AR/Rear: /



Marque PEUGEOT Modèle 205 T 16 N° Homol. B - 262  
Make \_\_\_\_\_ Model \_\_\_\_\_

- d) Matériau du capot AV  
Front bonnet material POLYESTER
- e) Matériau du capot/hayon AR  
Rear bonnet / tailgate material POLYESTER
- f) Matériau de la carrosserie  
Bodywork material TOLE ACIER
- g) Matériau du pare-brise  
Windscreen material VERRE FEUILLETE
- h) Matériau de la lunette AR  
Rear window material VERRE TREMPE
- i) Matériau des glaces de custode  
Rear quarter lights material POLYCARBONATE
- k) Matériau des vitres latérales  
Side window material AV / Front VERRE TREMPE  
AR / Rear /
- l) Matériau du pare-choc avant  
Material of the front bumper POLYURETHANE
- m) Matériau du pare-choc arrière  
Material of the rear bumper POLYURETHANE

**INFORMATIONS COMPLEMENTAIRES**

**COMPLEMENTARY INFORMATION**

- Angle entre soupapes admission et échappement : 49°30
- Rapport de boîte transfert 29/21 28/23  
1,380 1,217



Marque  
Make PEUGEOT

Modèle  
Model 205 T 16

N° Homol. B-262

PHOTOS / PHOTOS

Moteur / Engine

C) Profil droit du moteur déposé  
Right hand view of dismantled engine

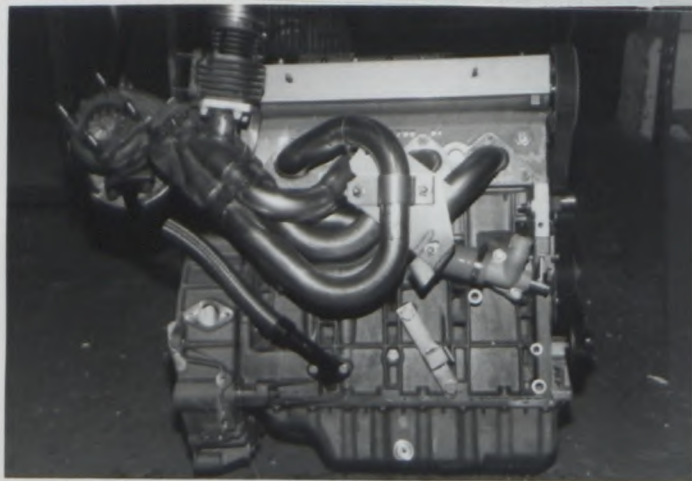

D) Profil gauche du moteur déposé  
Left hand view of dismantled engine

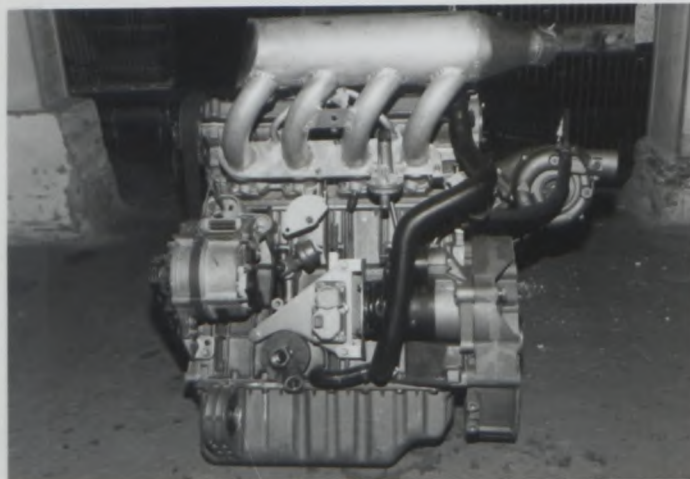

E) Moteur dans son compartiment  
Engine in its compartment



F) Culasse nue

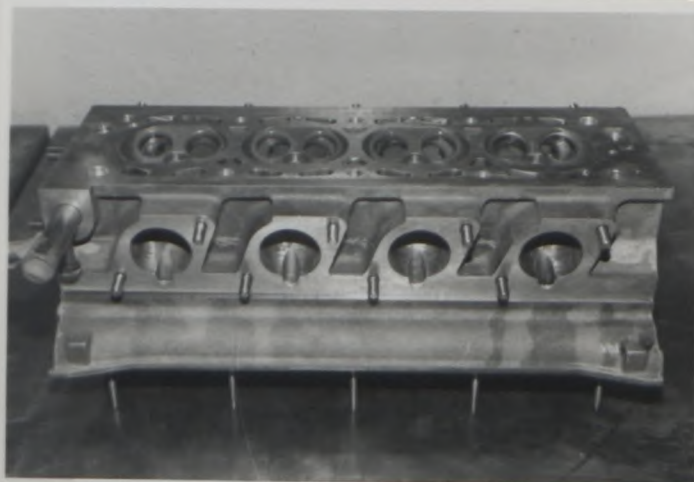

Marque PEUGEOT  
Make PEUGEOT

Modèle 205 T 16  
Model 205 T 16

N° Homol. B-262

G) Chambre de combustion  
Combustion chamber

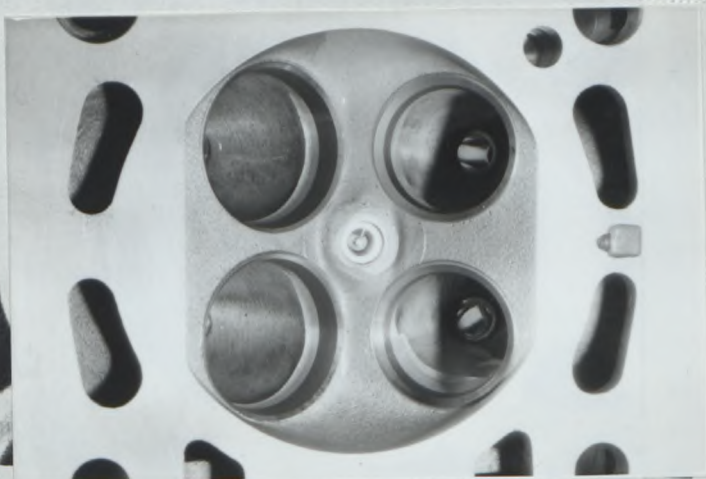

H) Carburateur(s) ou système d'injection

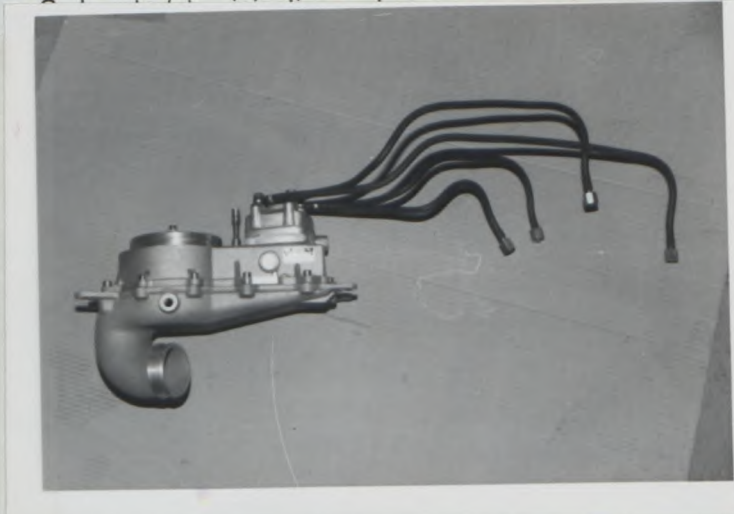

I) Collecteur d'admission  
Inlet manifold

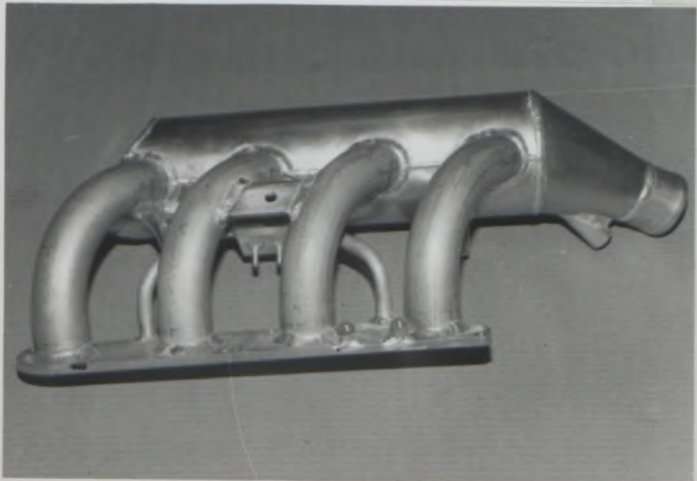

J) Collecteur d'échappement  
Exhaust manifold

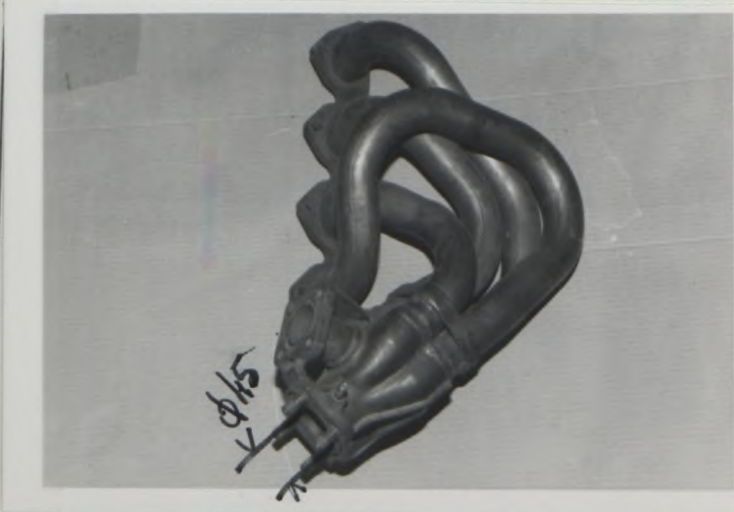

Transmission / Transmission

S) Carter de boîte de vitesse et cloche d'embrayage  
Gearbox casing and clutch bellhousing

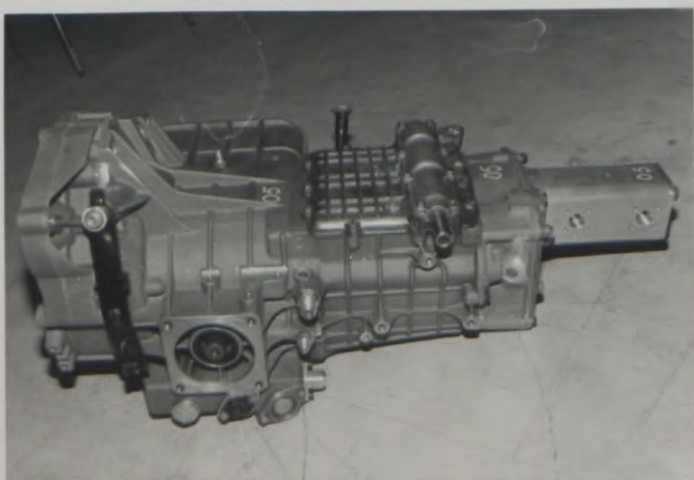

Marque  
Make

PEUGEOT

Modèle  
Model

205 T 16

N° Homol.

B-262

**Suspension / Suspension**

T) Train avant complet déposé

Complete dismantled front running gear

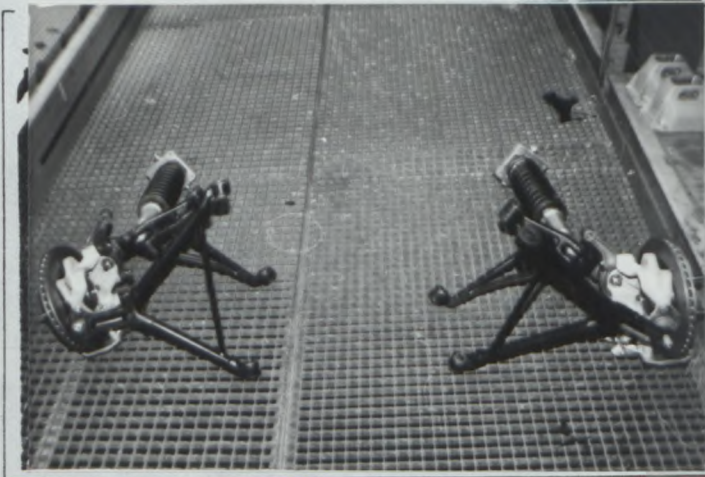

U) Train arrière complet déposé

Complete dismantled rear running gear

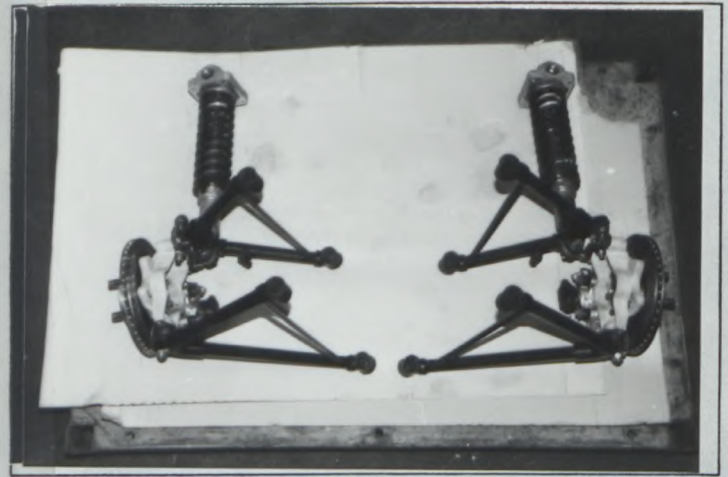

**Train roulant / Running gear**

V) Freins avant

Front brakes

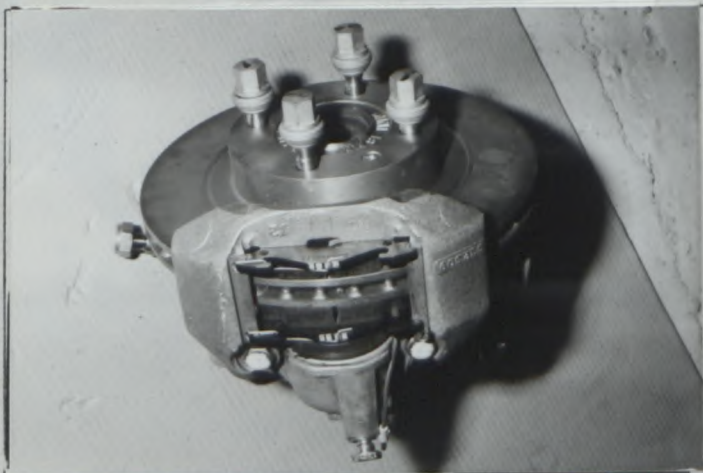

W) Freins arrière

Rear brakes

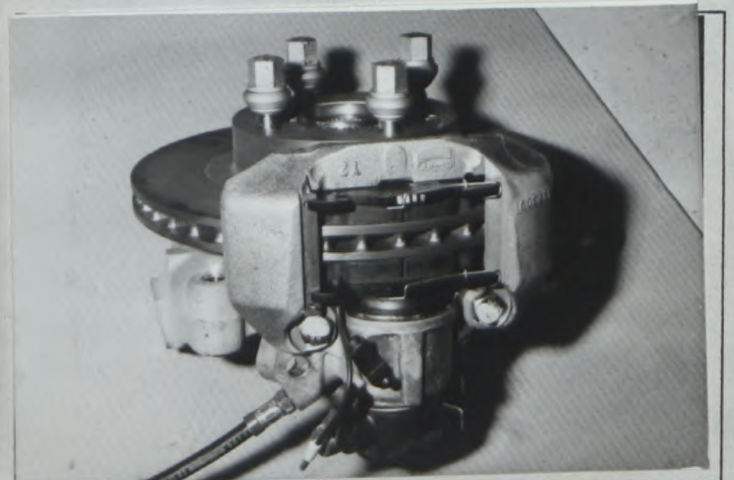

**Carrosserie / Bodywork**

X) Tableau de bord

Dashboard



Y) Toit ouvrant

Sunroof



DESSINS / DRAWINGS

Moteur / Engine

- I Orifices d'admission de la culasse, face collecteur (tolérances sur dimensions: -2%, +4%)  
 Cylinderhead inlet ports, manifold side (tolerances on dimensions: -2%, +4%)

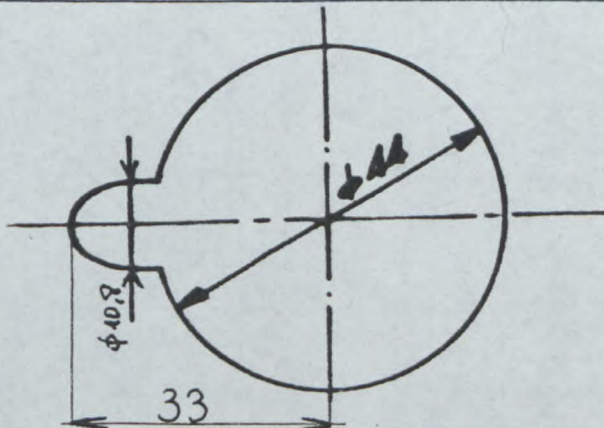

- II Orifices du collecteur d'admission, côté culasse (tolérances sur dimensions: -2%, +4%)  
 Inlet manifold ports, cylinderhead side (tolerances on dimensions: -2%, +4%)

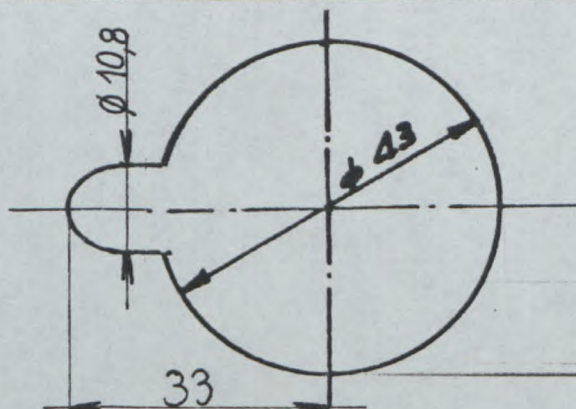

- III Orifices d'échappement de la culasse, face collecteur (tolérances sur dimensions: -2%, +4%)  
 Cylinderhead exhaust ports, manifold side (tolerances on dimensions: -2%, +4%)

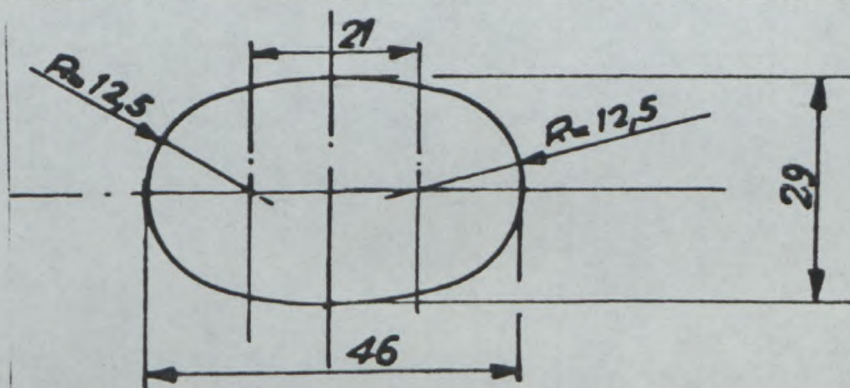

- IV Orifices du collecteur d'échappement, côté culasse (tolérances sur dimensions: -2%, +4%)  
 Exhaust manifold ports, cylinderhead side (tolerances on dimensions: -2%, +4%)

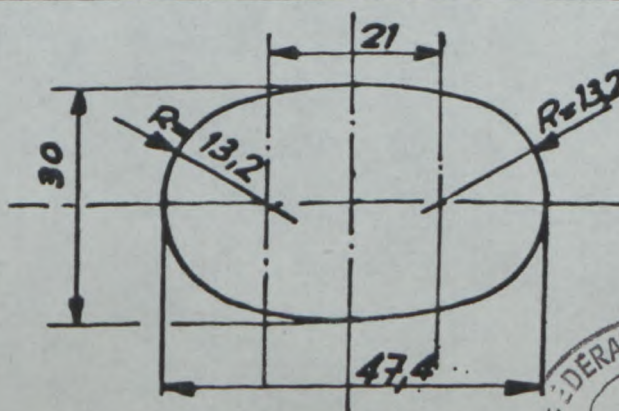



# FEDERATION INTERNATIONALE DU SPORT AUTOMOBILE

Homologation N°

B - 262

Groupe  
Group **A/B**

Marque PEUGEOT Modèle 205 T 16  
Make PEUGEOT Model 205 T 16

Dimensions intérieures comme définies par le Règlement d'Homologation  
Interior dimensions as defined by the Homologation Regulations.

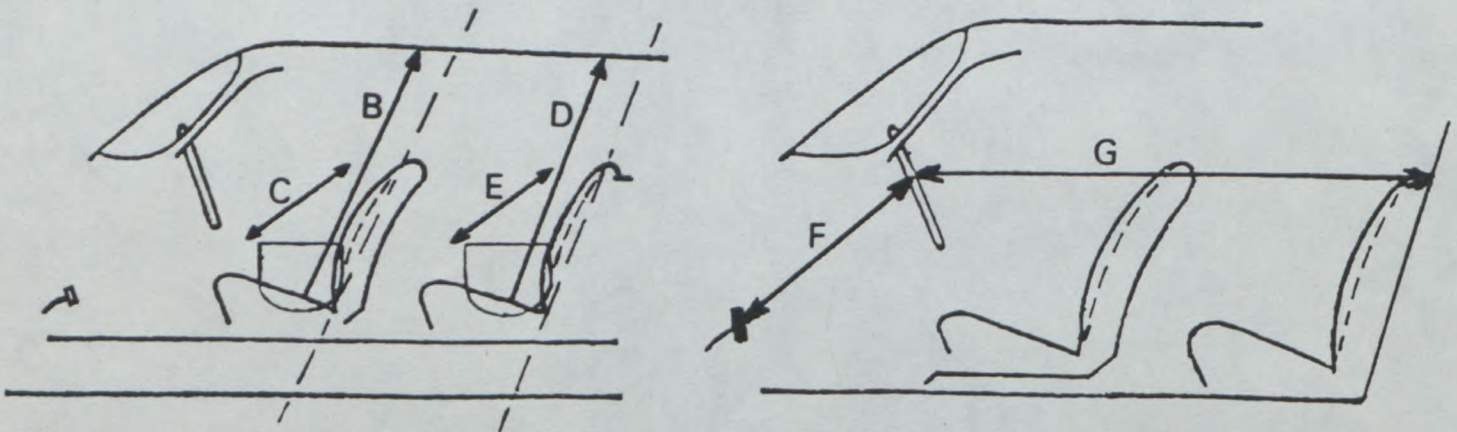

- B (Hauteur sur sièges avant)  
(Height above front seats) 941 mm
- C (Largeur aux sièges avant)  
(Width at front seats) 1308 mm
- D (Hauteur sur sièges arrière)  
(Height above rear seats) / mm
- E (Largeur aux sièges arrière)  
(Width at rear seats) / mm
- F (Volant - Pédale de frein)  
(Steering wheel - brake pedal) 674 mm
- G (Volant - paroi de séparation arrière)  
(Steering wheel - rear bulkhead) 787 mm
- H = F + G = 1461 mm





# FEDERATION INTERNATIONALE DU SPORT AUTOMOBILE

Homologation N°

**B - 262**

Groupe **A/B**  
Group

## FICHE D'HOMOLOGATION ADDITIONNELLE POUR MOTEURS SURALIMENTÉS PAR TURBOCOMPRESSEUR(S) ADDITIONAL HOMOLOGATION FORM FOR TURBO CHARGED ENGINES

Véhicule : Constructeur PEUGEOT Modèle et type 205 T16  
Vehicle : Manufacturer PEUGEOT Model and type 205 T16

Homologation valable à partir du \_\_\_\_\_ en groupe B  
Homologation valid as from \_\_\_\_\_ in group B

334. Suralimentation Turbocharging a) Marque et type du turbo compresseur KKK K26  
Make and type of the turbocharger KKK K26

b) Carter de turbine : Turbine housing : b1) Nombre d'entrées des gaz d'échappement 1  
Number of exhaust gas entries 1

b2) Matériau FONTE  
Material FONTE

c) Roue de turbine : Turbine wheel : c1) Matériau ACIER  
Material ACIER

c2) Nombre d'aubes 12 c3) Hauteur(s) d'une aube 23,3 mm  
Number of blades 12 Height(s) of blade 23,3 mm

c4) Préciser les cotes A,B,C, selon le schéma suivant :  
Indicate the dimensions A, B, C, according to the following sketch :

A = 54,5 mm  
B = \_\_\_\_\_ mm  
C = 64,5 mm

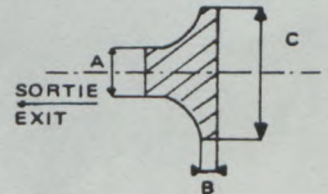

d) Carter de compression : Impeller housing : d1) Nombre d'entrée d'air (mélange) 1  
Number of air entries (gas) 1

d2) Matériau ALLIAGE ALUMINIUM  
Material ALLIAGE ALUMINIUM

e) Roue de compression Impeller wheel : e2) Nombre d'aubes 12 e3) Hauteur(s) d'une aube 22 mm  
Number of blades 12 Height(s) of blade 22 mm

e4) Préciser les cotes A, B, C selon le schéma suivant :  
Indicate the dimensions A, B, C, according to the following sketch,

A = 43 mm  
B = \_\_\_\_\_ mm  
C = 66 mm

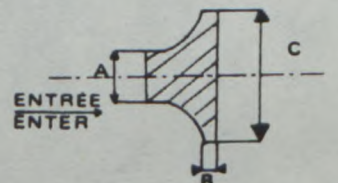





M) Vue de côté du turbocompresseur  
Side view of turbocharger



N) Carter de turbine du turbocompresseur  
Turbine housing of turbocharger



O) Soupape et montage du by-pass du turbocompresseur  
Valve and by-pass installation of turbocharger

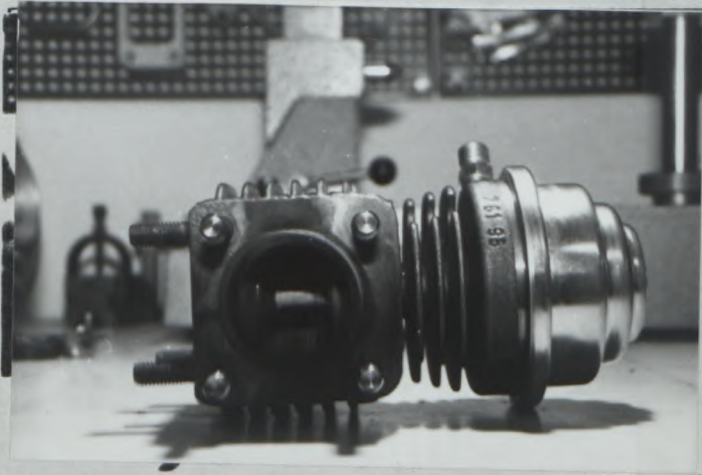

P) Eventuel échappement entre le collecteur d'échappement et le turbocompresseur.  
Eventual exhaust pipes between the exhaust manifold and the turbocharger.

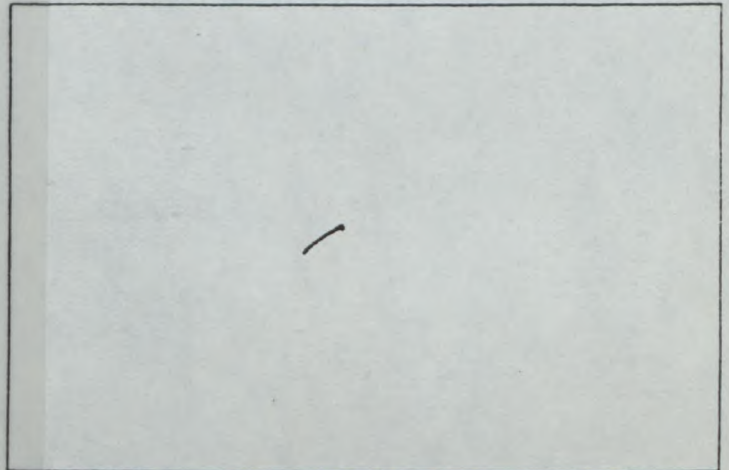

Q) Carter de compression du turbocompresseur  
Impeller housing of turbocharger



DESSINS / DRAWINGS

V) Entrée des gaz d'échappement dans le carter de turbine du turbocompresseur  
Exhaust gas entry in the turbine housing of turbocharger.

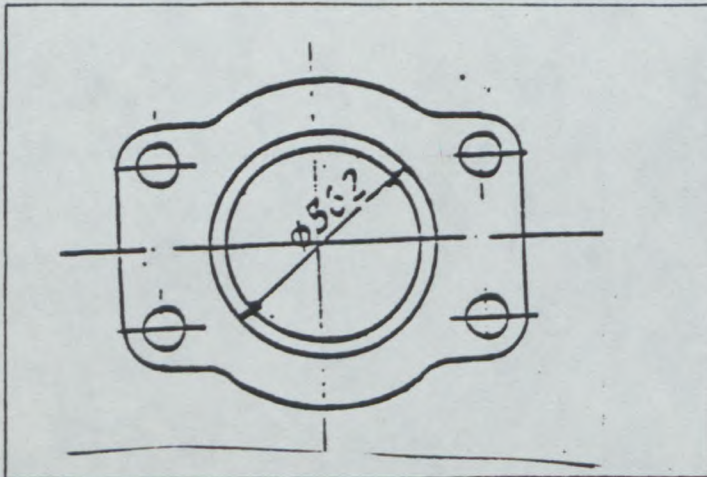

VI) Sortie des gaz d'échappement du carter de turbine c turbocompresseur.  
Exhaust gas exit of the turbine housing of turbocharge

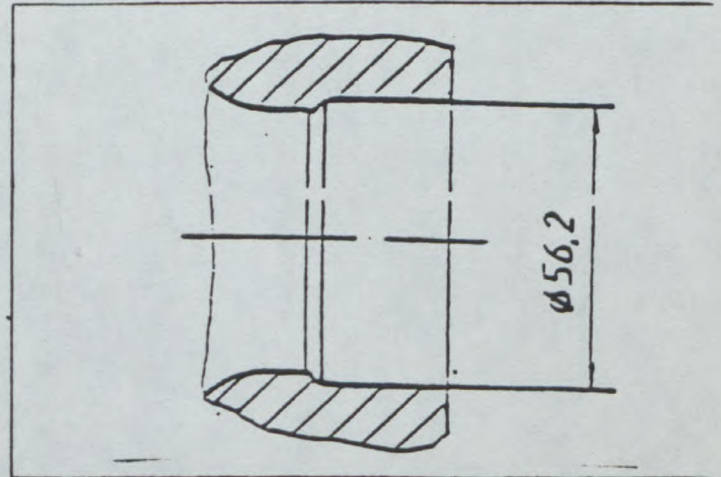

VII) Entrée de l'air (mélange) dans le carter de compression du turbocompresseur.  
Air (gas) entry in the impeller housing of the turbocharger

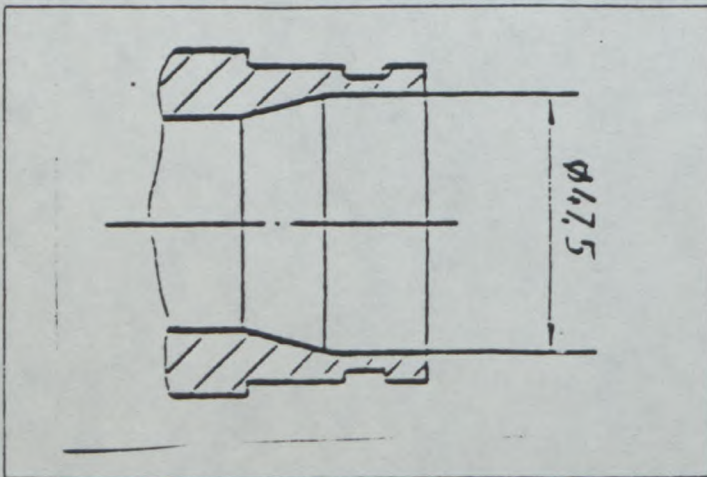

VIII) Sortie de l'air (mélange) du carter de compression d turbocompresseur.  
Air (gas) exit of the impeller housing of the turbocharge

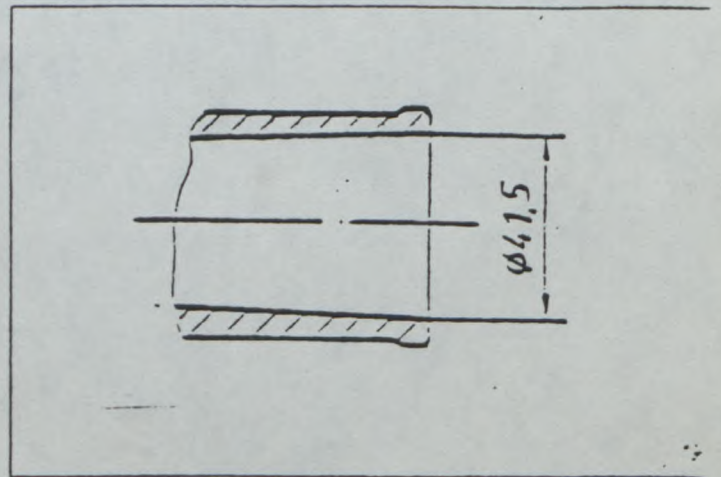

IX. Dispositif réglant la pression de suralimentation  
Device regulating the turbocharging pressure.

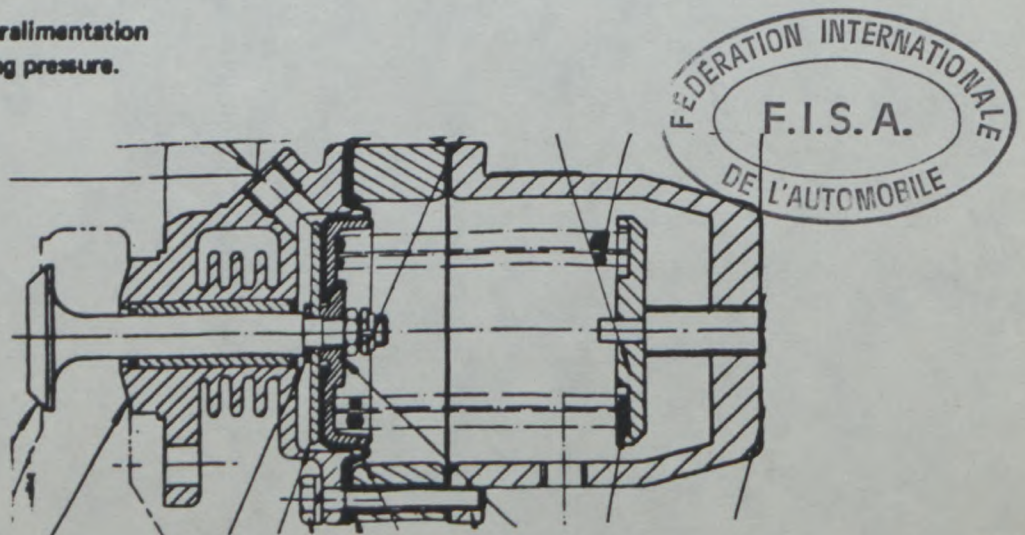



# FEDERATION INTERNATIONALE DU SPORT AUTOMOBILE

Homologation N°

B - 262

Extension N°

01 / 01 VO

FICHE D'EXTENSION A L'HOMOLOGATION OFFICIELLE FISA  
FORM OF EXTENSION TO THE OFFICIAL FISA HOMOLOGATION

ET Evolution normale du type: dès le numéro de châssis  
Normal evolution of the type: as from chassis number \_\_\_\_\_

VF Variante de fourniture / Supply variant

VO Variante option / Option variant

ER Errata / Erratum

Homologation valable dès le  
Homologation valid as from

01 AVR. 1984

en groupe  
in group B

Constructeur  
Manufacturer PEUGEOT

Modèle et type  
Model and type 205 TURBO 16

Page ou ext. Page or ext.	Art. Art.	Description Description		
		Amortisseur AV	Photo	1
		Amortisseur AR avec 2 ressorts	Photo	2
		Triangle de suspension AV inférieur	Photo	3
		supérieur	Photo	4
		Triangle de suspension AR inférieur	Photo	5
		supérieur	Photo	6
		Fixation supérieure d'amortisseur AV	Photo	7
		AR	Photo	8
		Barre anti-devers AV	Photo	9
		AR	Photo	10
9	804	Crémaillère rapport de direction	15,5/1 - 14,1/1	
	606	Arbre de transmission renforcé	Photo 11 et 12	



Marque PEUGEOT  
 Make

Modèle 205 T 16  
 Model

N° Homol. B-262

N° Ext. 01/01V0

Page ou ext. Page or ext.	Art. Art.	Description Description	
		- Pédalier double maître cylindre avec réglage par palonnier	Photo 13
		$\varnothing .75$ 19,05 m/m	
		$\varnothing .70$ 17,78 m/m	
		- Frein à main hydraulique $\varnothing .825$ 20,96 m/m	Photo 14
		- Bielette renforcée de suspension AR	Photo 15
		- Carter sec	
		b) Nb. de pompe 1 à 5 étages	Photo 16
		- Toit ouvrant	Photo 21
		- Joint de cardan de direction	Photo 22
		- Réservoirs essence 54 l et 54 l. même emplacement que ceux d'origine	Photo 23 /23bis
		- Réservoirs essence 54 l. et 25 l. même emplacement que ceux d'origine	Photo 24 /24bis
		- Triangle de suspension AV. Inf.	Photo 25
		Sup. .	Photo 26
		- Triangle de suspension AR. Inf.	Photo 27
		Sup.	Photo 28





# FEDERATION INTERNATIONALE DU SPORT AUTOMOBILE

Homologation N°

**B-262**

Extension N°

**01/01 Vn**

FICHE D'EXTENSION A L'HOMOLOGATION OFFICIELLE FISA  
FORM OF EXTENSION TO THE OFFICIAL FISA HOMOLOGATION

**ET** Evolution normale du type: dès le numéro de châssis  
Normal evolution of the type: as from chassis number \_\_\_\_\_

**VF** Variante de fourniture / Supply variant

**VO** Variante option / Option variant

**ER** Errata / Erratum

Homologation valable dès le  
Homologation valid as from \_\_\_\_\_

en groupe  
in group B

Constructeur  
Manufacturer PEUGEOT

Modèle et type  
Model and type 205 TURBO 16

Page ou ext. Page or ext.	Art. Art.	Description Description	Photo	17-18	19-20																	
				<table border="1"> <thead> <tr> <th>Avant / Front</th> <th>Arrière / Rear</th> </tr> </thead> <tbody> <tr> <td>4</td> <td>4</td> </tr> <tr> <td>38,1 mm</td> <td>38,1 mm</td> </tr> <tr> <td>_____ mm (± 1.5 mm)</td> <td>_____ mm (± 1.5 mm)</td> </tr> <tr> <td>_____ cm<sup>2</sup></td> <td>_____ cm<sup>2</sup></td> </tr> <tr> <td>_____ mm</td> <td>_____ mm</td> </tr> </tbody> </table>	Avant / Front	Arrière / Rear	4	4	38,1 mm	38,1 mm	_____ mm (± 1.5 mm)	_____ mm (± 1.5 mm)	_____ cm <sup>2</sup>	_____ cm <sup>2</sup>	_____ mm	_____ mm						
Avant / Front	Arrière / Rear																					
4	4																					
38,1 mm	38,1 mm																					
_____ mm (± 1.5 mm)	_____ mm (± 1.5 mm)																					
_____ cm <sup>2</sup>	_____ cm <sup>2</sup>																					
_____ mm	_____ mm																					
		<p>e) Nombre de cylindres par roue. Number of cylinders per wheel:</p> <p>e1) Alésage Bore</p> <p>f) Freins à tambours: Drum brakes:</p> <p>f1) Diamètre intérieur Interior diameter</p> <p>f2) Nombre de mâchoires par roue. Number of shoes per wheel</p> <p>f3) Surface de freinage Braking surface</p> <p>f4) Largeur des garnitures Width of the shoes</p> <p>g) Freins à disques: Disc brakes:</p> <p>g1) Nombres de sabots par roue Number of pads per wheel</p> <p>g2) Nombre d'étriers par roue Number of callipers per wheel</p>																				
		<p>g3) Matériau des étriers Calliper material</p> <p>g4) Epaisseur maximale du disque Maximum disc thickness</p> <p>g5) Diamètre extérieur du disque Exterior diameter of the disc</p> <p>g6) Diamètre extérieur de frottement des sabots Exterior diameter of the shoe's rubbing surface</p> <p>g7) Diamètre intérieur de frottement des sabots Interior diameter of the shoe's rubbing surface</p> <p>g8) Longueur hors-tout des sabots Overall length of the shoes</p> <p>g9) Disques ventilés Ventilated disc</p> <p>g10) Surface de freinage par roue Braking surface per wheel</p>		<table border="1"> <thead> <tr> <th>AV / Front</th> <th>AR / Rear</th> </tr> </thead> <tbody> <tr> <td>alu</td> <td>alu</td> </tr> <tr> <td>25,8 mm</td> <td>25,8 mm</td> </tr> <tr> <td>278 mm (± 1 mm)</td> <td>278 mm (± 1 mm)</td> </tr> <tr> <td>278 mm</td> <td>278 mm</td> </tr> <tr> <td>184 mm</td> <td>184 mm</td> </tr> <tr> <td>126,5 mm</td> <td>126,5 mm</td> </tr> <tr> <td>oui/yes yes/no</td> <td>oui/yes yes/no</td> </tr> <tr> <td>682 cm<sup>2</sup></td> <td>682 cm<sup>2</sup></td> </tr> </tbody> </table>	AV / Front	AR / Rear	alu	alu	25,8 mm	25,8 mm	278 mm (± 1 mm)	278 mm (± 1 mm)	278 mm	278 mm	184 mm	184 mm	126,5 mm	126,5 mm	oui/yes yes/no	oui/yes yes/no	682 cm <sup>2</sup>	682 cm <sup>2</sup>
AV / Front	AR / Rear																					
alu	alu																					
25,8 mm	25,8 mm																					
278 mm (± 1 mm)	278 mm (± 1 mm)																					
278 mm	278 mm																					
184 mm	184 mm																					
126,5 mm	126,5 mm																					
oui/yes yes/no	oui/yes yes/no																					
682 cm <sup>2</sup>	682 cm <sup>2</sup>																					





# FEDERATION INTERNATIONALE DU SPORT AUTOMOBILE

Homologation N°

**B-262**

Extension N°

**01/01 VO**

FICHE D'EXTENSION A L'HOMOLOGATION OFFICIELLE FISA  
FORM OF EXTENSION TO THE OFFICIAL FISA HOMOLOGATION

- ET** Evolution normale du type: dès le numéro de châssis  
Normal evolution of the type: as from chassis number \_\_\_\_\_
- VF** Variante de fourniture / Supply variant
- VO** Variante option / Option variant
- ER** Errata / Erratum

Homologation valable dès le \_\_\_\_\_ en groupe **B**  
Homologation valid as from \_\_\_\_\_ in group \_\_\_\_\_

Constructeur PEUGEOT Modèle et type 205 TURBO 16  
Manufacturer \_\_\_\_\_ Model and type \_\_\_\_\_

Page ou ext. Page or ext.	Art. Art.	Description Description	Photo	29	30
				Avant / Front	Arrière / Rear
		e) Nombre de cylindres par roue: Number of cylinders per wheel:		4	4
		e1) Alésage Bore		41,2 mm	41,2 mm
		f) Freins à tambours: Drum brakes:			
		f1) Diamètre intérieur Interior diameter		_____ mm (± 1.5 mm)	_____ mm (± 1.5 mm)
		f2) Nombre de mâchoires par roue. Number of shoes per wheel			
		f3) Surface de freinage Braking surface		_____ cm <sup>2</sup>	_____ cm <sup>2</sup>
		f4) Largeur des garnitures Width of the shoes		_____ mm	_____ mm
		g) Freins à disques: Disc brakes:			
		g1) Nombre de sabots par roue Number of pads per wheel			
		g2) Nombre d'étriers par roue Number of callipers per wheel			
		g3) Matériau des étriers Caliper material		Alu	Alu
		g4) Epaisseur maximale du disque Maximum disc thickness		28 mm	28 mm
		g5) Diamètre extérieur du disque Exterior diameter of the disc		300 mm (± 1 mm)	300 mm (± 1 mm)
		g6) Diamètre extérieur de frottement des sabots Exterior diameter of the shoe's rubbing surface		300 mm	300 mm
		g7) Diamètre intérieur de frottement des sabots Interior diameter of the shoe's rubbing surface		195,10 mm	_____ mm
		g8) Longueur hors-tout des sabots Overall length of the shoes		126,5 mm	126,5 mm
		g9) Disques ventilés Ventilated disc		oui/yes yes/yes	oui/yes yes/per
		g10) Surface de freinage par roue Braking surface per wheel		816 cm <sup>2</sup>	816 cm <sup>2</sup>



Marque  
Make PEUGEOT

Modèle  
Model 205 T 16

N° Homol. **B-262**

PHOTOS / PHOTOS

N° Ext. **01/01V0**

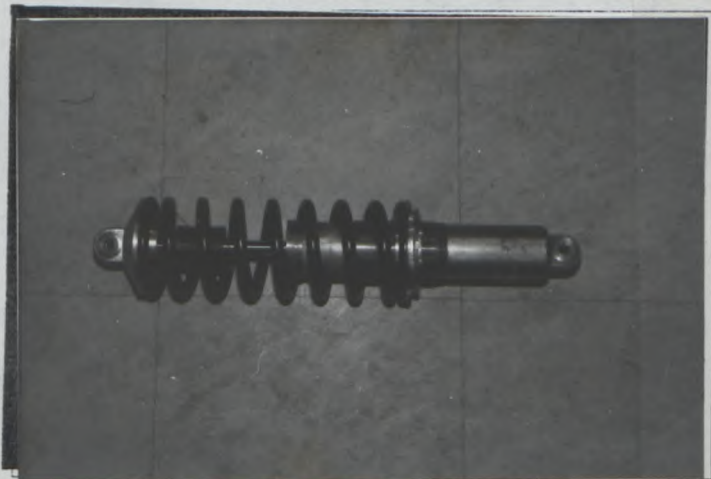

1

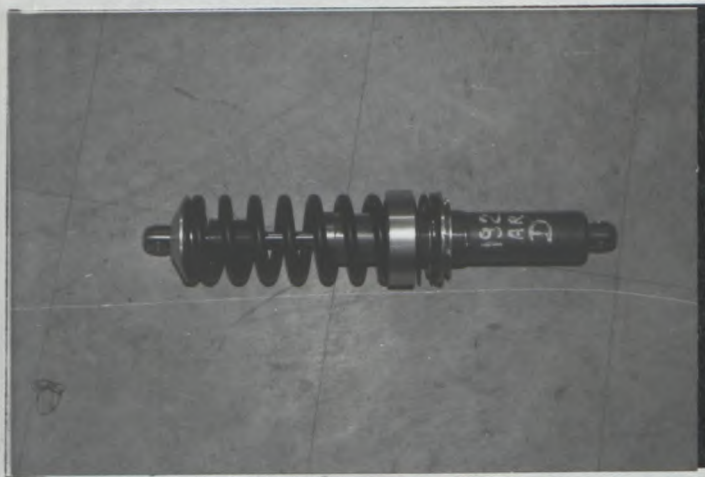

2



3



4



5



6





PHOTOS / PHOTOS

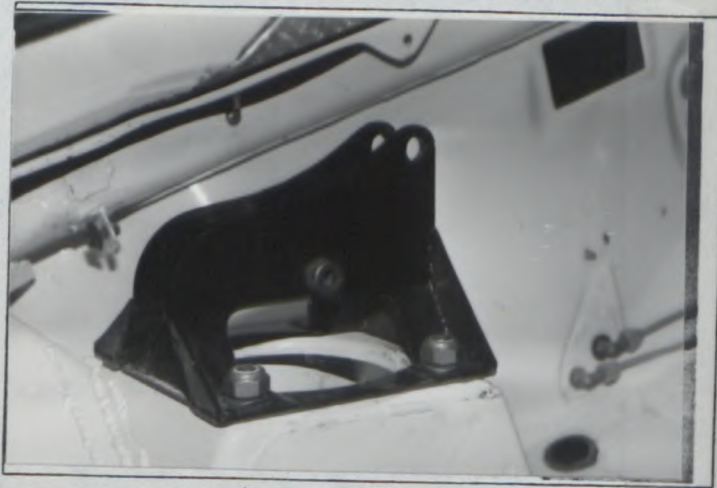

7



8



9

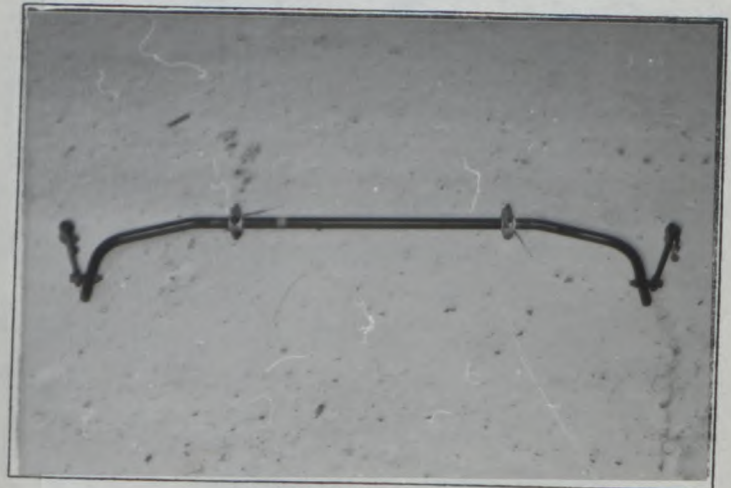

10



11

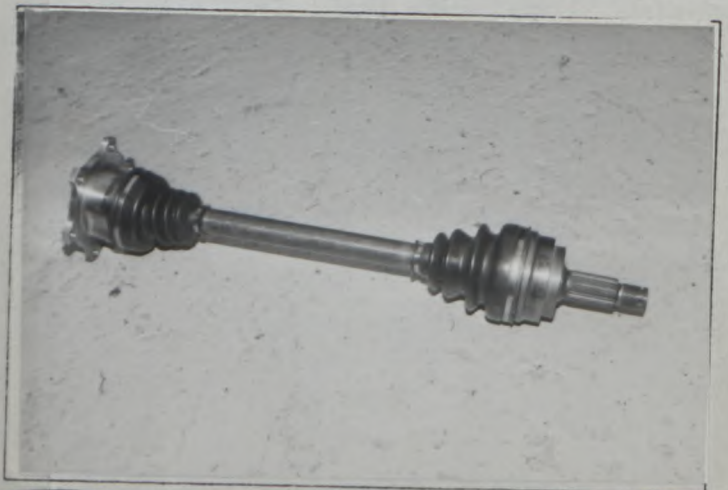

12



Marque PEUGEOT  
Make PEUGEOT

Modèle 205 T 16  
Model 205 T 16

B-262

N° Homol. \_\_\_\_\_

PHOTOS / PHOTOS

N° Ext. 01 / 01 V0

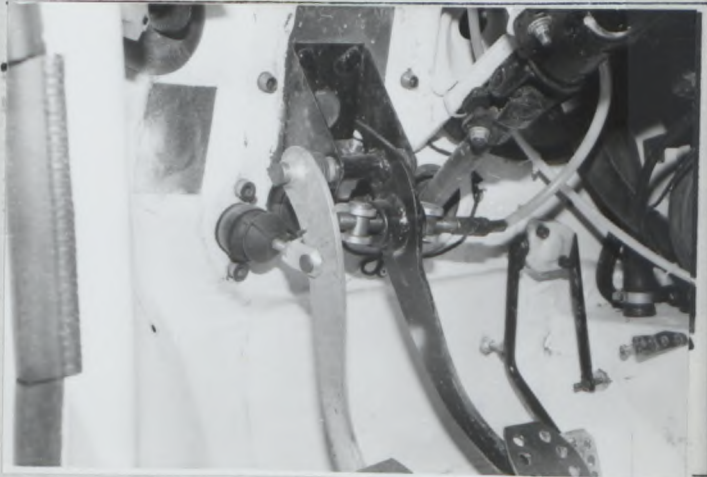

13

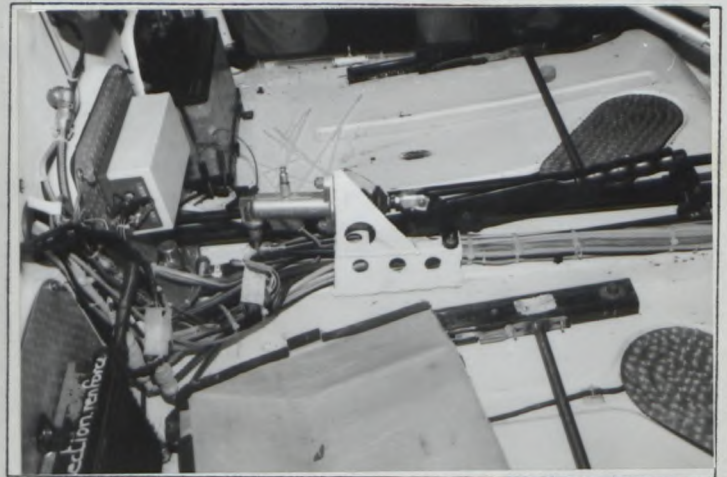

14

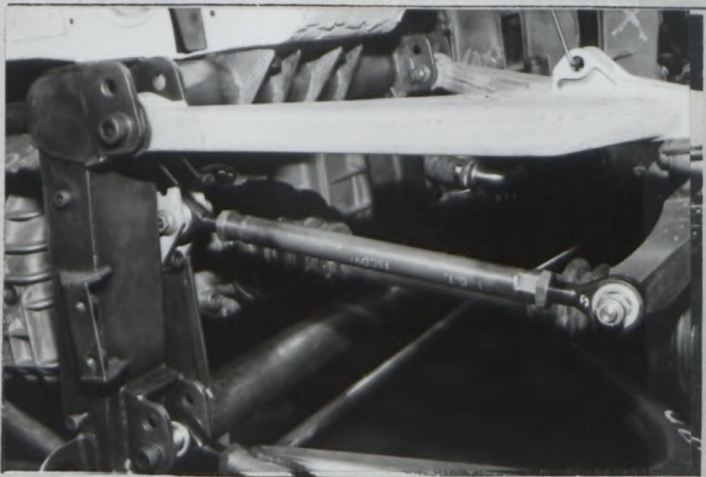

15

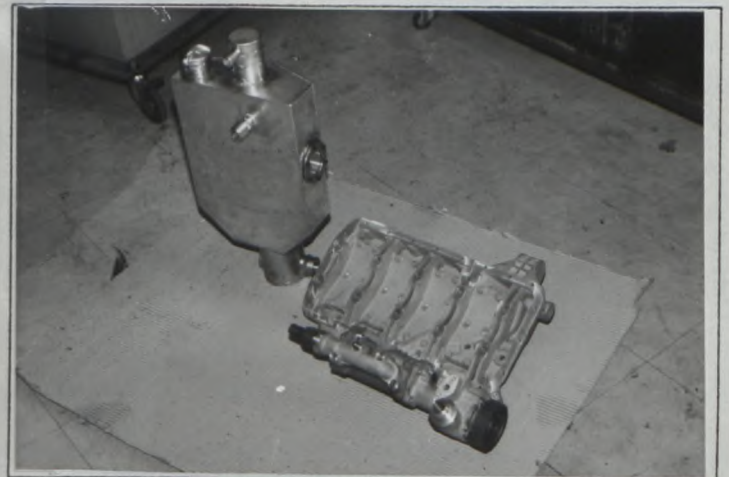

16

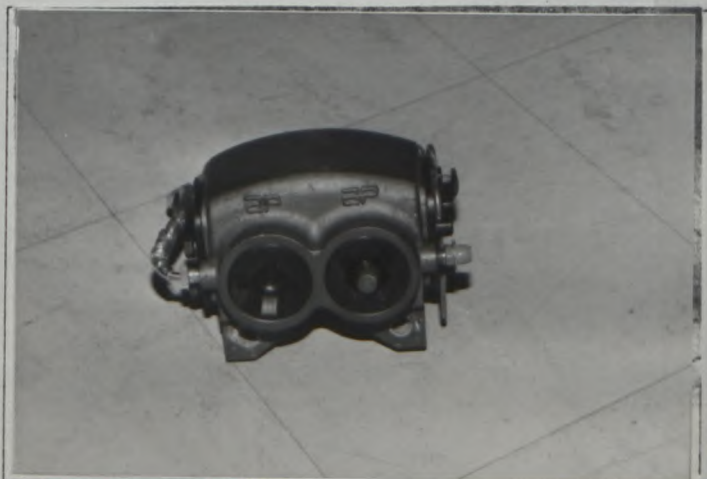

17

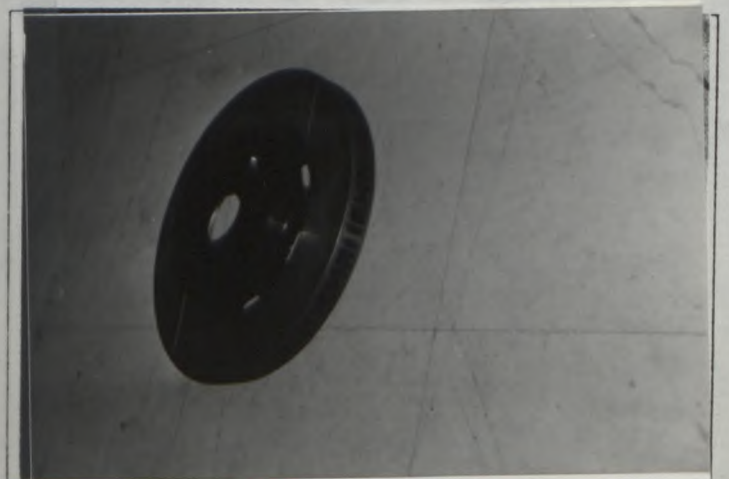

18



Marque PEUGEOT  
Make

Modèle 205 T 16  
Model

N° Homol. \_\_\_\_\_

**B-262**

PHOTOS / PHOTOS

N° Ext. 01/01V0

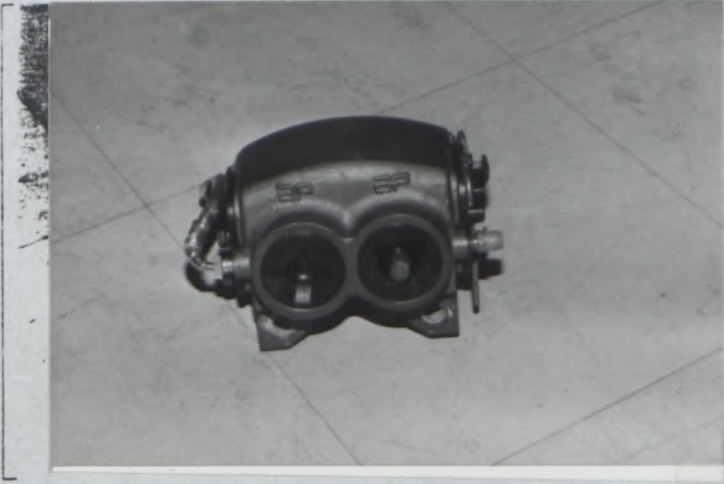

19

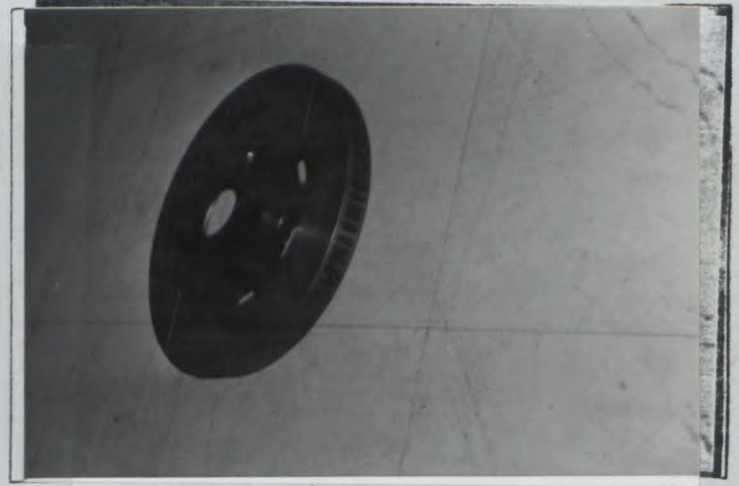

20



21

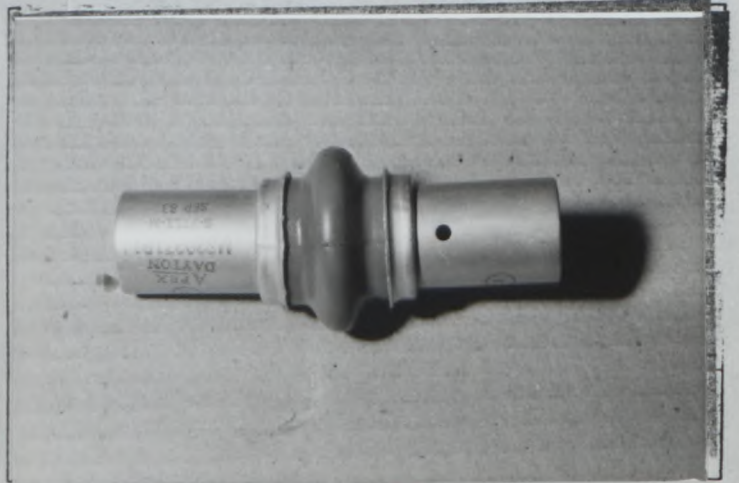

22



Marque  
Make

Modèle  
Model

N° Homol. **B - 262**

PHOTOS / PHOTOS

N° Ext. **01 / 01 vn**



23

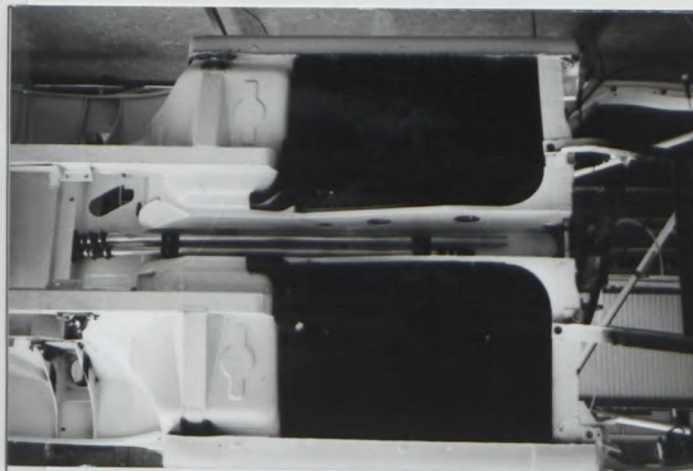

23 bis



24



24 bis

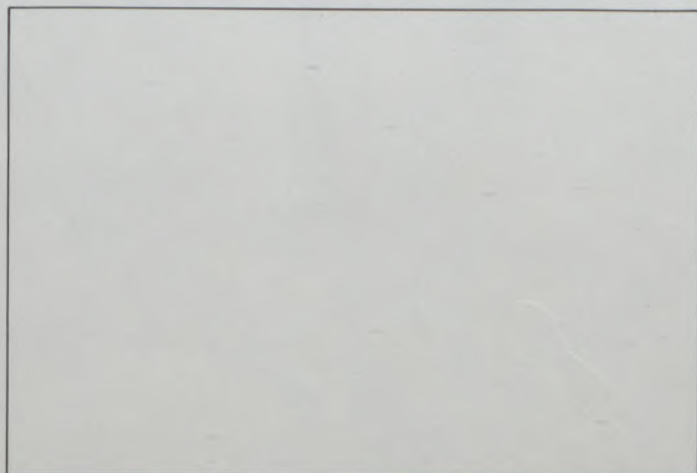

Marque  
Make PEUGEOT

Modèle  
Model 205 T 16

N° Homol. B-262

PHOTOS / PHOTOS

N° Ext. 01/01V0

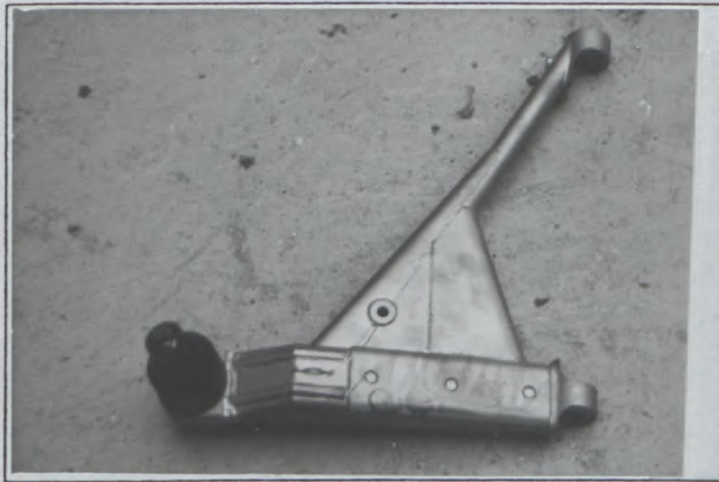

25



26



27



28



29



30





# FEDERATION INTERNATIONALE DU SPORT AUTOMOBILE

Homologation N°

B-262

Extension N°

02/01 ET

FICHE D'EXTENSION A L'HOMOLOGATION OFFICIELLE FISA  
FORM OF EXTENSION TO THE OFFICIAL FISA HOMOLOGATION

**ET** Evolution normale du type: dès le numéro de châssis  
Normal evolution of the type: as from chassis number \_\_\_\_\_

**VF** Variante de fourniture / Supply variant

**VO** Variante option / Option variant

**ER** Errata / Erratum

Homologation valable dès le 01 AVR. 1984 en groupe B  
Homologation valid as from \_\_\_\_\_ in group \_\_\_\_\_

Constructeur PEUGEOT Modèle et type 205 TURBO 16  
Manufacturer \_\_\_\_\_ Model and type \_\_\_\_\_

Page ou ext. Page or ext.	Art. Art	Description Description
3	318	- Bielle e) Poids minimum : 66,0 g
	319	- Vilebrequin h) Poids minimum : 15400 g
	320	- Volant moteur b) Poids : 3900 g
4	325	- Distribution e) Levée maximum des soupapes admission : 11,5 Echappement : 11,5 avec jeu : 0,3 : 0,3
4	327	- Admission a) Matériau du collecteur : alliage aluminium Photo 1 b) Nombre d'éléments : 2 e) Diamètre de la tige de soupape : 8 m/m
4	324	Alimentation par injection - débitmètre 8 sorties d) dimension effectives du joint de mesure au papillon : 60 m/m



Photo 2

Marque PEUGEOT Modèle 205 T 16 N° Homol. **B-262**

N° Ext. **02/01 ET**

Page ou ext. Page or ext.	Art. Art.	Description Description	
	327	- Dispositif de régulation de l'air d'admission monté en amont de la turbine de compresseur commande groupée avec celle du papillon.  - Nouveau turbo compresseur : voir fiche spécifique	Photo 3
5	328	Echappement a) Matériau du collecteur : tôle acier f) Diamètre de la tige de soupape : 8 m/m	Photo 4
	330	Système d'allumage a) type distributeur - bobine - batterie  - moteur profil droit  - moteur profil gauche	Photo 5 Photo 6
5	602	- Embrayage c) nombre de disques : 2	



Marque  
Make PEUGEOT

Modèle  
Model 205 TURBO 16

N° Homol. B-262

N° Ext. 02/01 FT

Page ou ext. Page or ext.	Art. Art.	Description Description	
		- Arceau intégré à la carrosserie Matériau acier 15 CD V6	Photo 7
		- Plancher abaissé sous les sièges	Photo 8
		- Berceau AR	Photo 9
		- Ouverture dans le pare-choc AV	Photo 10
		- Divers renforts de caisse Photo 11 à 22	
		- Voiture de 3/4 AV	Photo 23
		3/4 AR	Photo 24
		- Amélioration de l'entrée d'air sur les ailes AR droite et gauche	Photo 25 Photo 26
		- Amélioration de la sortie d'air sur capot AV	Photo 27
		- Sur capot moteur	
		- Prise d'air supérieur	Photo 28
		- Ouverture latérale	Photo 29
		- + Manche à air intégré	Photo 30
		- Suppression de la plage AR	Photo 31
		- Nouvelle planche de bord	Photo 32
		- Matériau de la lunette arrière : Polycarbonate	
		- Matériau des vitres latérales : Polycarbonate	
901		- <u>Intérieur</u> : Suppression de tout le garnissage	
		a) Ventilation : OUI	
		b) Chauffage : NON	
		c) Fenêtres ) glissières pratiquées dans les glaces fixes de portières en plastique	Photo 33
		- Tirant gauche caisse - berceau	Photo 34
		- Tirant droit berceau - moteur	Photo 35
		- Ouverture dans la cloison arrière pour logement de la batterie.	Photo 36 37
		- Renfort d'appui de pédalier	Photo 38





Marque PEUGEOT  
Make

Modèle 205 T 16  
Model

N° Homol B-262

PHOTOS / PHOTOS

N-Ext 02/01 ET



1

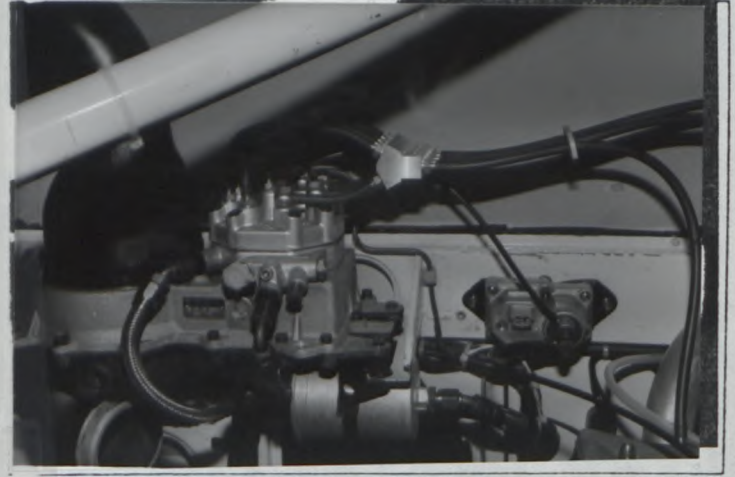

2



3

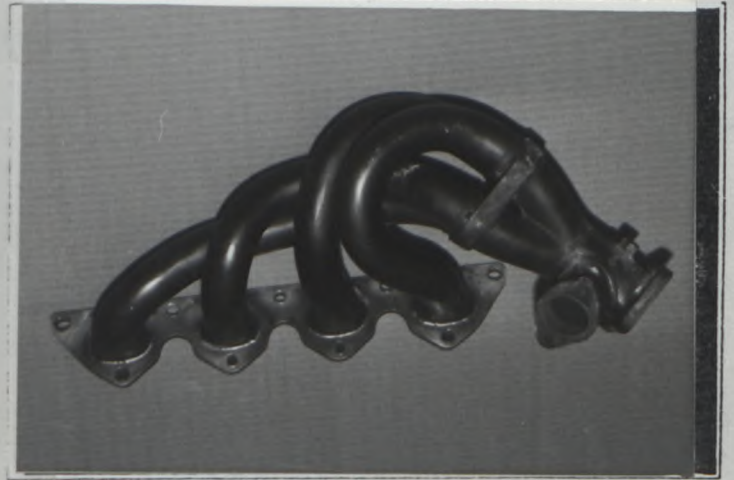

4

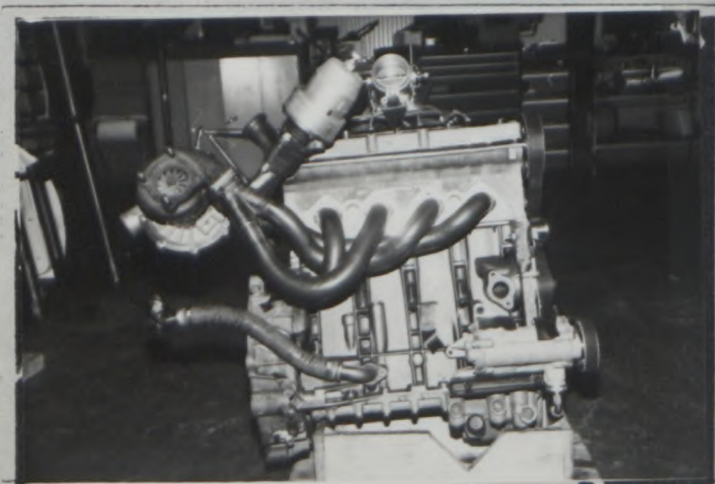

5

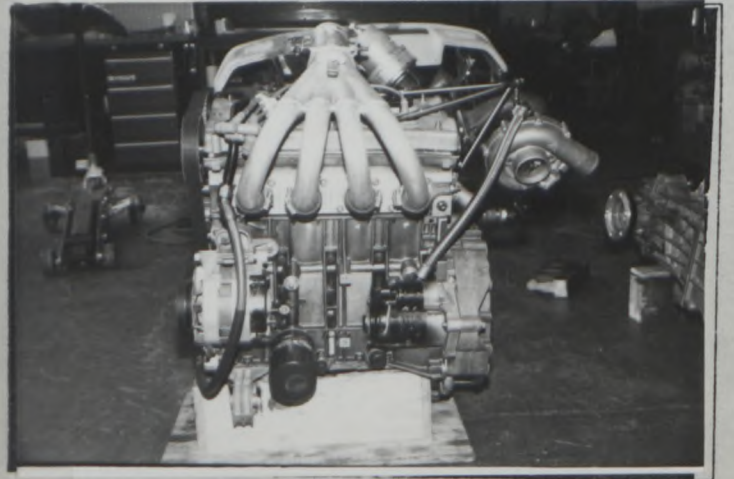

Marque PEUGEOT  
Make

Modèle 205 T 16  
Model

N° Homol B-262

02/01 ET

PHOTOS / PHOTOS

N° Ext.



7

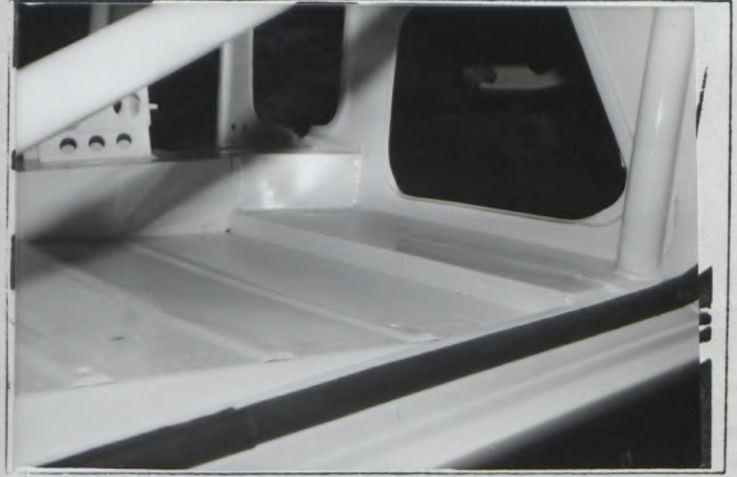

8

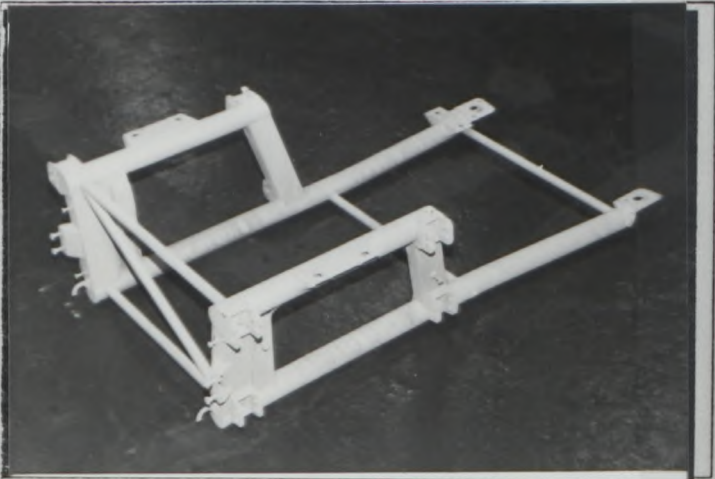

9



10

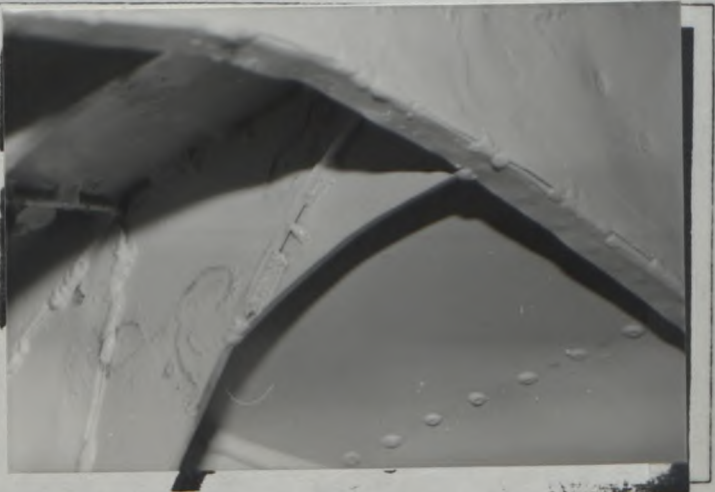

11



Marque  
Make PEUGEOT

Modèle  
Model 205 T 16

N° Homol. **B-262**

PHOTOS / PHOTOS

N° Ext. **02/01 ET**

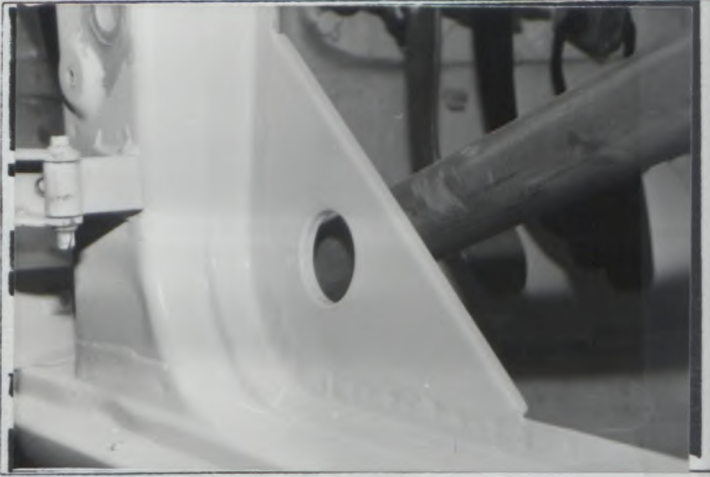

13



14



15



16

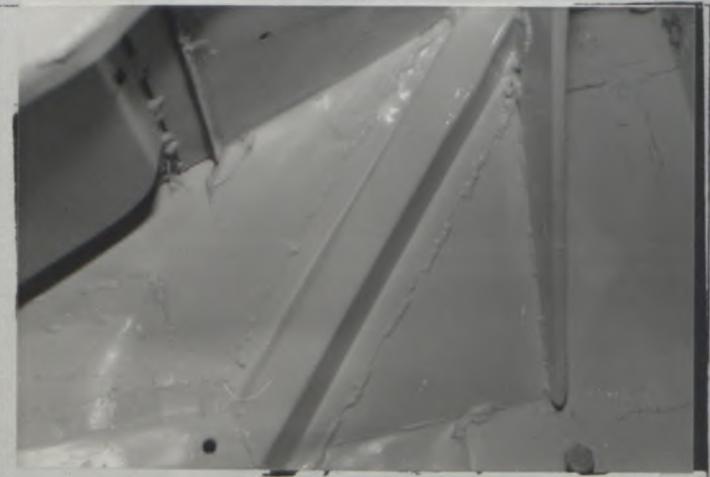

17



18



Marque  
Make

PEUGEOT

Modèle  
Model

205 T 16

N° Homol.

B-262

PHOTOS / PHOTOS

N° Ext.

02 / 01 FT

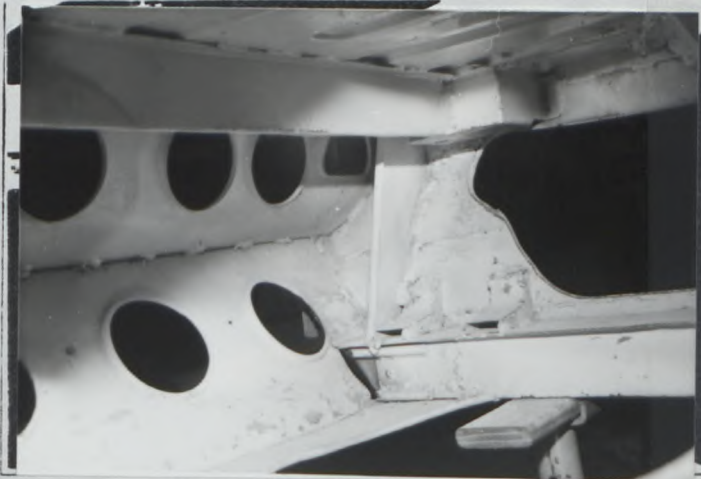

19



20

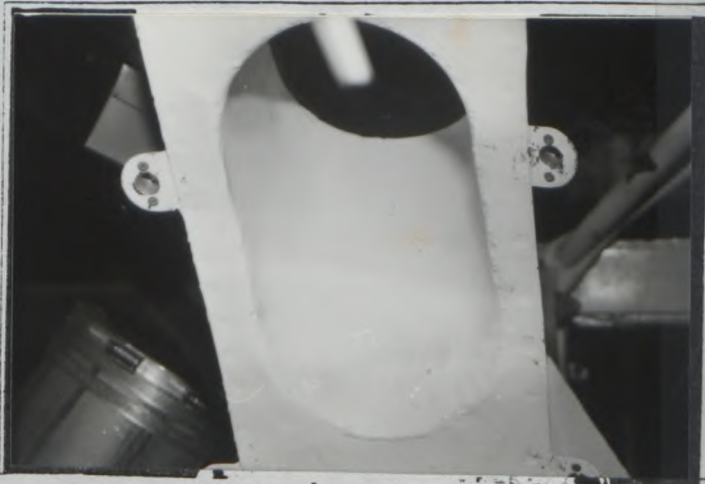

21

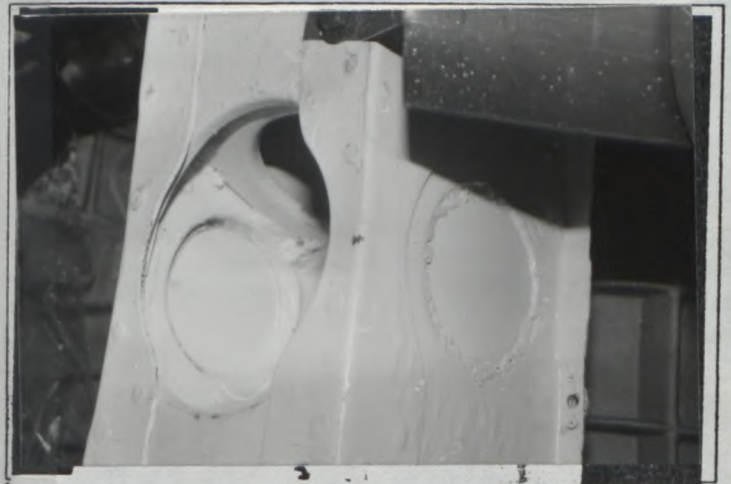

22



23



24



Marque  
Make PEUGEOT

Modèle  
Model 205 T 16

N° Homol B-262

PHOTOS / PHOTOS

N° Ext. 02/01 ET



25



26



27



28



29



Marque  
Make

PEUGEOT

Modèle  
Model

205 T 16

N° Homol.

B-262

PHOTOS / PHOTOS

N° Ext.

02/01 ET



31



32



33

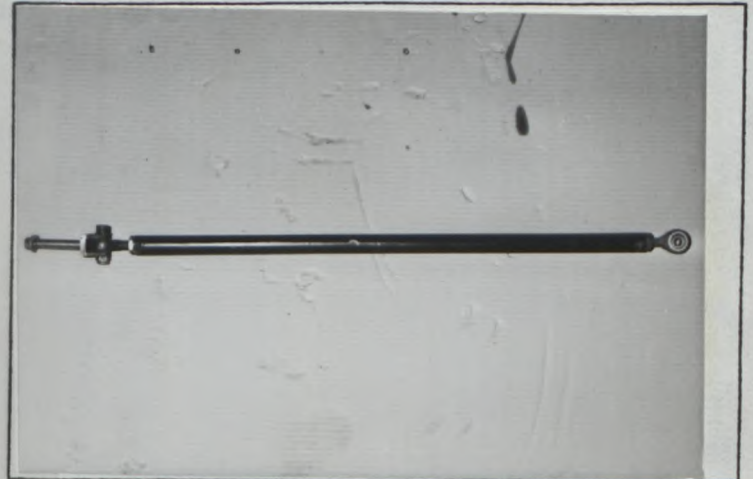

34



35



36



Marque PEUGEOT  
Make

Modèle 205 T 16  
Model

N° Homol. B-262

PHOTOS / PHOTOS

N° Ext. 02/01 ET



37

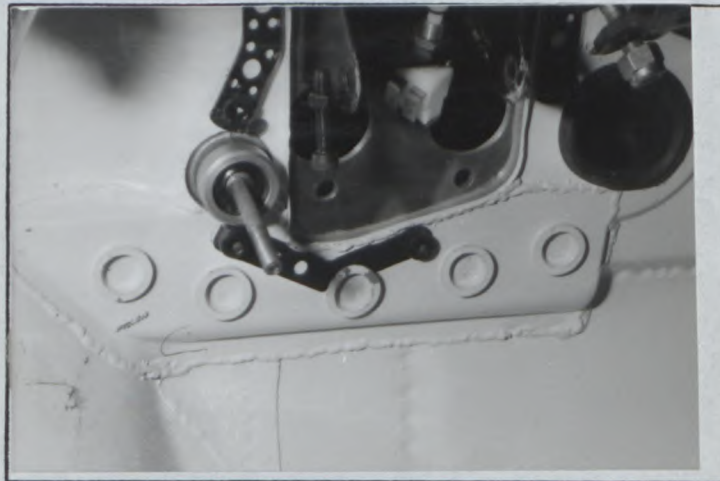

38

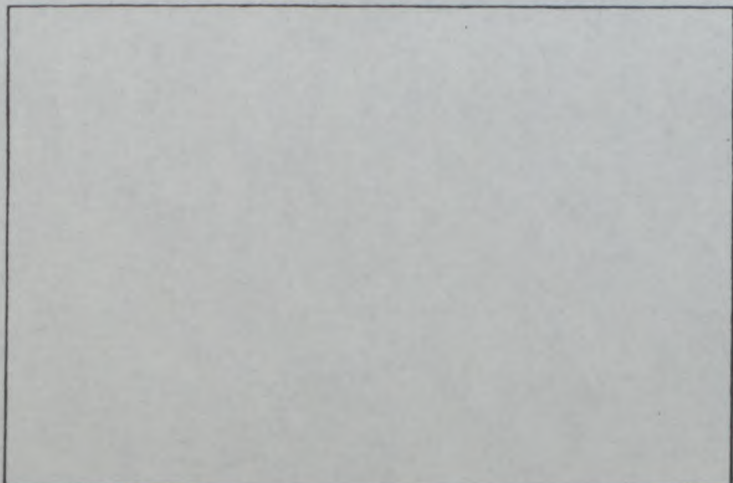
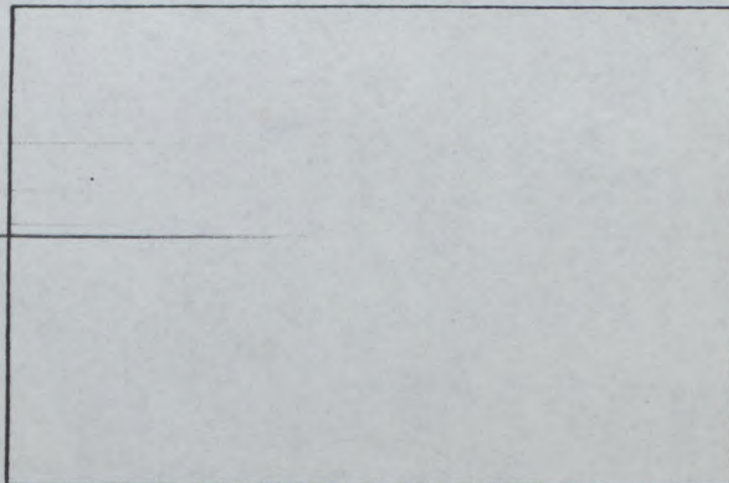
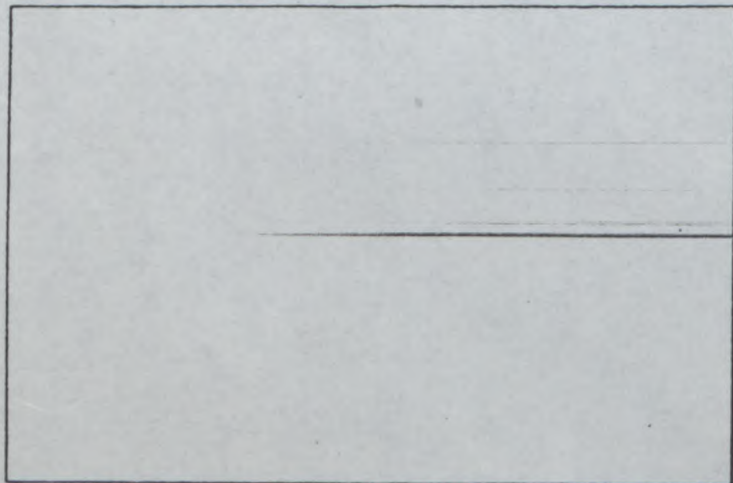



# FEDERATION INTERNATIONALE DU SPORT AUTOMOBILE

Homologation N°

**B - 262****02 / 01 ET**Groupe  
Group **A/B**

## FICHE D'HOMOLOGATION ADDITIONNELLE POUR MOTEURS SURALIMENTÉS PAR TURBOCOMPRESSEUR(S) ADDITIONAL HOMOLOGATION FORM FOR TURBO CHARGED ENGINES

Véhicule : Constructeur PEUGEOT Modèle et type 205 T16  
 Vehicle : Manufacturer PEUGEOT Model and type 205 T16

Homologation valable à partir du \_\_\_\_\_ en groupe B  
 Homologation valid as from \_\_\_\_\_ in group B

334. Suralimentation  
Turbocharging

a) Marque et type du turbo compresseur  
Make and type of the turbocharger KKK K26

b) Carter de turbine :  
Turbine housing :

b1) Nombre d'entrées des gaz d'échappement  
Number of exhaust gas entries 2

b2) Matériau  
Material FONTE

c) Roue de turbine :  
Turbine wheel :

c1) Matériau  
Material ACIER

c2) Nombre d'aubes  
Number of blades 12

c3) Hauteur(s) d'une aube  
Height(s) of blade 23,3 mm

c4) Préciser les cotes A, B, C, selon le schéma suivant :  
Indicate the dimensions A, B, C, according the following sketch :

A = 54,5 mm  
 B = \_\_\_\_\_ mm  
 C = 64,5 mm

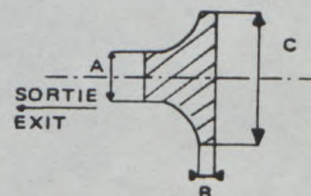

d) Carter de compression :  
Impeller housing :

d1) Nombre d'entrée d'air (mélange)  
Number of air entries (gas) 1

d2) Matériau  
Material ALLIAGE D'ALUMINIUM

e) Roue de compression  
Impeller wheel :

e2) Nombre d'aubes  
Number of blades 12

e3) Hauteur(s) d'une aube  
Height(s) of blade 26 mm

e4) Préciser les cotes A, B, C selon le schéma suivant :  
Indicate the dimensions A, B, C, according to the following sketch,

A = 51 mm  
 B = \_\_\_\_\_ mm  
 C = 76 mm

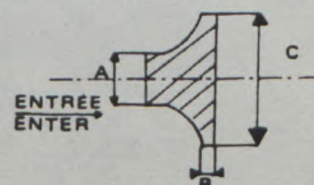



Marque PEUGEOT Modèle 205 T16 N° Homol. B-262  
Make \_\_\_\_\_ Model \_\_\_\_\_

02/01 ET

f) Régulation de la pression :  
Pressure regulation :

f1) Type de régulation de la pression :  by-pass  soupape de décharge relief valve  autre cas other case  
Type of pressure adjustment :

f2) Préciser le type de la soupape et son contrôle WASTE GATE REGLABLE  
Indicate the type of the valve and its control \_\_\_\_\_

g) Système d'échappement :  
Exhaust system :

Dimensions intérieures de l'éventuel tuyau d'échappement entre le collecteur d'échappement et le turbocompresseur (dessin)  
Internal dimensions of the eventual exhaust pipes between exhaust manifold and turbocharger (sketch)

h) Refroidissement de l'air d'admission : oui/yes  
Cooling of intake air : yes/no



PHOTOS

k) Vue de dessus du turbo compresseur  
Plan view of turbocharger

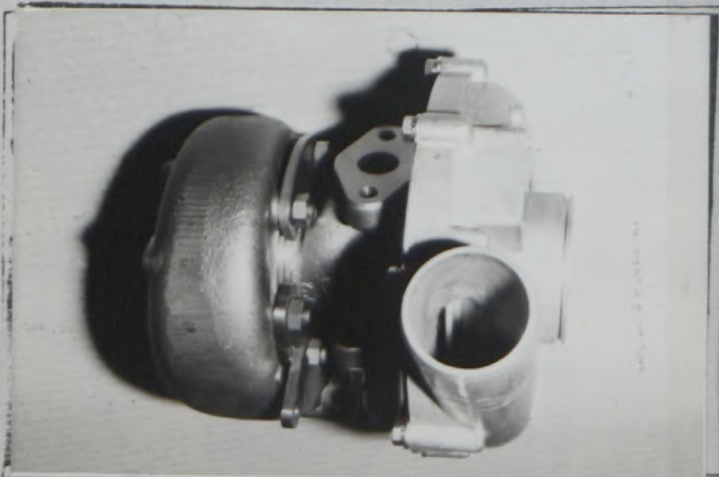

l) Vue de face du turbo compresseur  
Front view of turbocharger

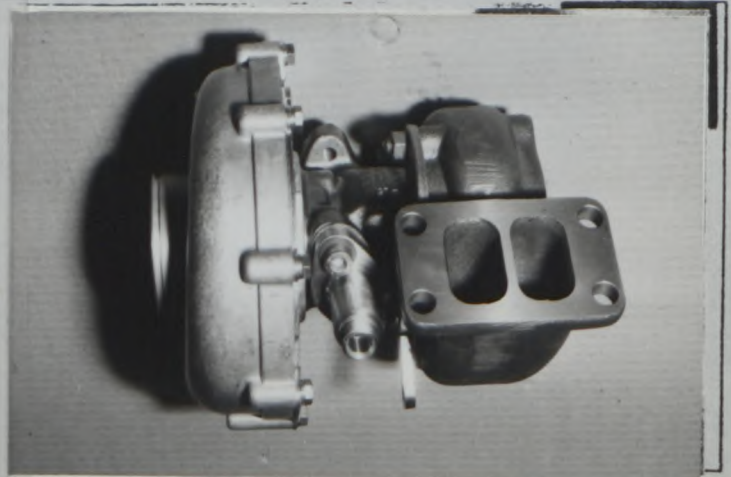

M) Vue de côté du turbocompresseur  
Side view of turbocharger



N) Carter de turbine du turbocompresseur  
Turbine housing of turbocharger



O) Soupape et montage du by-pass du turbocompresseur  
Valve and by-pass installation of turbocharger

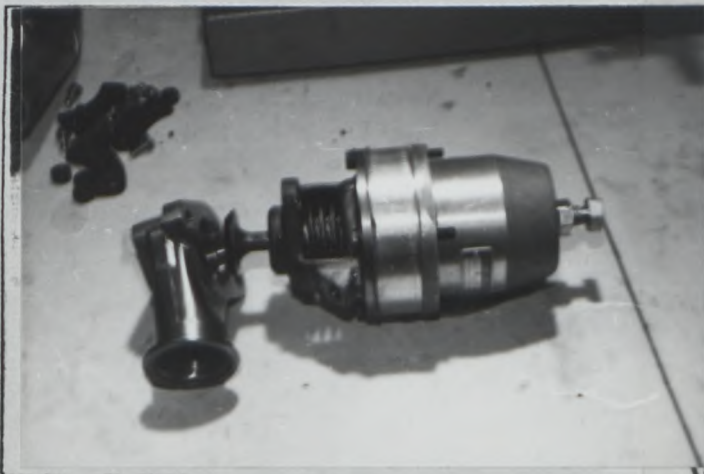

P) Eventuel échappement entre le collecteur d'échappement et le turbocompresseur.  
Eventual exhaust pipes between the exhaust manifold and the turbocharger.

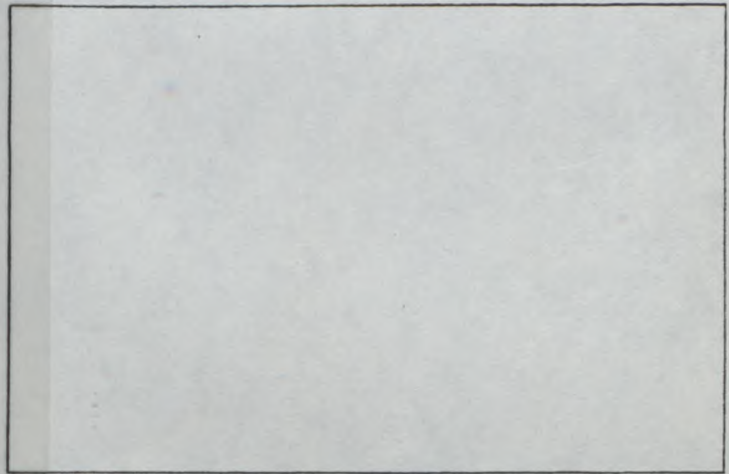

Q) Carter de compression du turbocompresseur  
Impeller housing of turbocharger

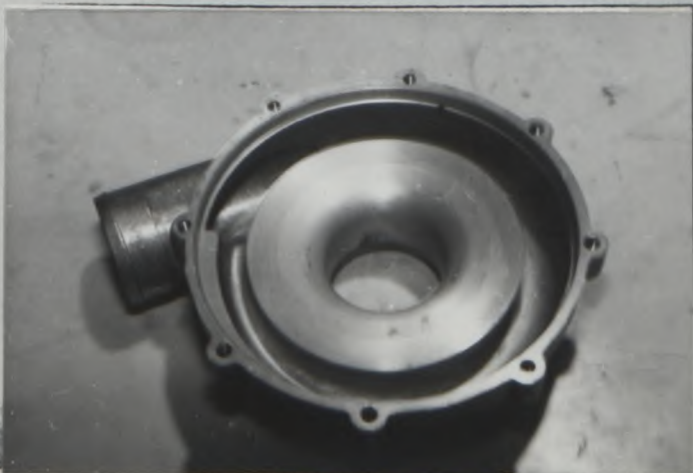

DESSINS / DRAWINGS

V) Entrée des gaz d'échappement dans le carter de turbine du turbocompresseur  
Exhaust gas entry in the turbine housing of turbocharger.

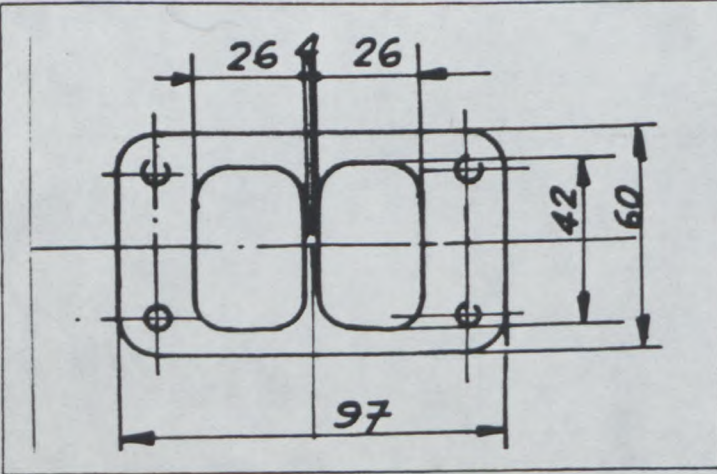

VI) Sortie des gaz d'échappement du carter de turbine de turbocompresseur.  
Exhaust gas exit of the turbine housing of turbocharger.

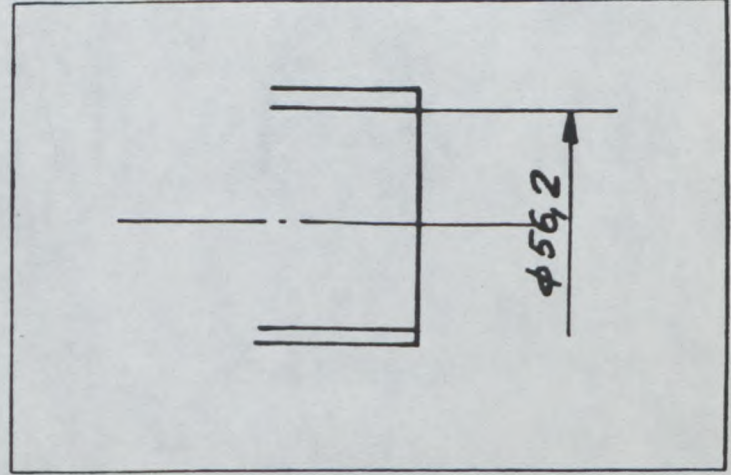

VII) Entrée de l'air (mélange) dans le carter de compression du turbocompresseur.  
Air (gas) entry in the impeller housing of the turbocharger

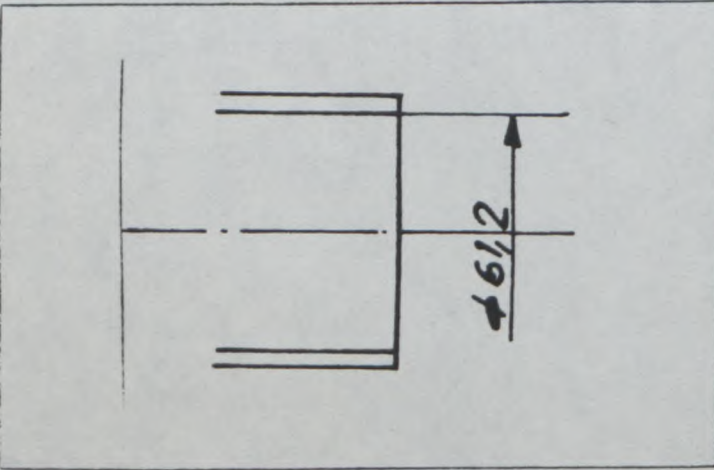

VIII) Sortie de l'air (mélange) du carter de compression du turbocompresseur.  
Air (gas) exit of the impeller housing of the turbocharger.

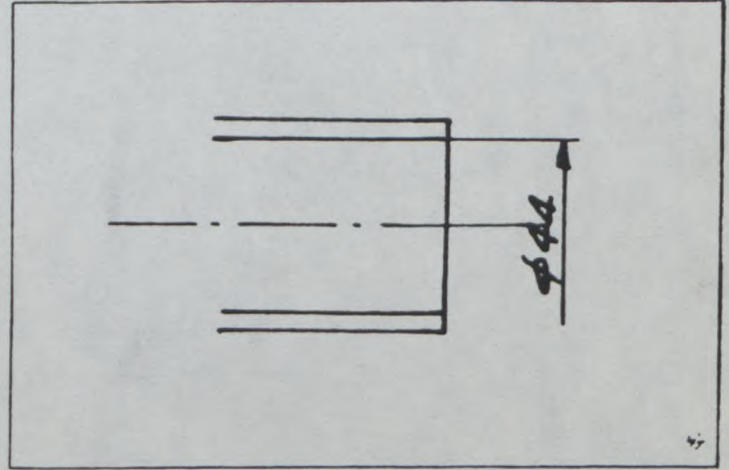

IX. Dispositif réglant la pression de suralimentation  
Device regulating the turbocharging pressure.

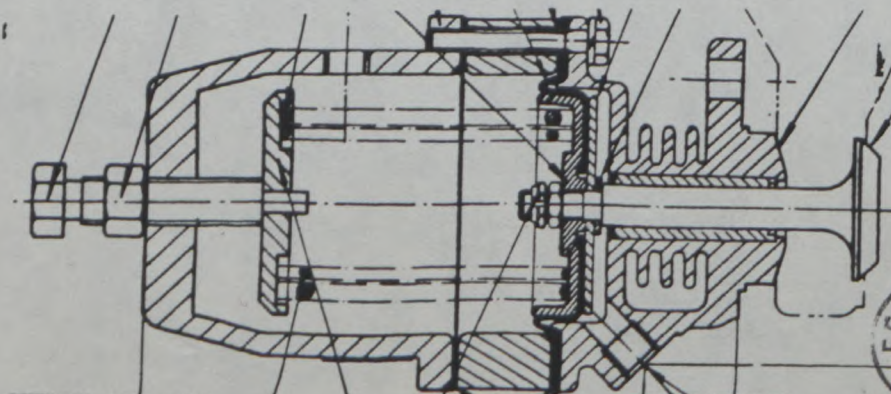



# FEDERATION INTERNATIONALE DU SPORT AUTOMOBILE

Homologation N°

B 262

Extension N°

**03 / 01 ER**

FICHE D'EXTENSION A L'HOMOLOGATION OFFICIELLE FISA  
FORM OF EXTENSION TO THE OFFICIAL FISA HOMOLOGATION

- ET Evolution normale du type: dès le numéro de châssis  
Normal evolution of the type: as from chassis number \_\_\_\_\_
- VF Variante de fourniture / Supply variant
- VO Variante option / Option variant
- ER Errata / Erratum

Homologation valable dès le \_\_\_\_\_ en groupe \_\_\_\_\_  
Homologation valid as from **- 1 JUIL. 1984** in group **B**

Constructeur PEUGEOT Modèle et type 205 TURBO 16  
Manufacturer \_\_\_\_\_ Model and type \_\_\_\_\_

Page ou ext. Page or ext.	Art. Art	Description Description
2	203	<ul style="list-style-type: none"><li>- Largeur hors tout 1 700 m/m au lieu de 1 674.</li><li>- Endroit de la mesure axe de roue AR au lieu de axe de roue AV.</li><li>- Largeur de la carrosserie :<ul style="list-style-type: none"><li>b) à la hauteur de l'axe AR 1 700 au lieu de 1 664</li></ul></li></ul>





# FEDERATION INTERNATIONALE DU SPORT AUTOMOBILE

Homologation N°

B 262

Extension N°

04 / 02 VO

FICHE D'EXTENSION A L'HOMOLOGATION OFFICIELLE FISA  
FORM OF EXTENSION TO THE OFFICIAL FISA HOMOLOGATION

- ET** Evolution normale du type: dès le numéro de châssis  
Normal evolution of the type: as from chassis number \_\_\_\_\_
- VF** Variante de fourniture / Supply variant
- VO** Variante option / Option variant
- ER** Errata / Erratum

Homologation valable dès le **- 1 AOUT 1984** en groupe **B**  
Homologation valid as from \_\_\_\_\_ in group \_\_\_\_\_

Constructeur **PEUGEOT** Modèle et type **205 T 16**  
Manufacturer \_\_\_\_\_ Model and type \_\_\_\_\_

Page ou ext. Page or ext	Art Art	Description Description	
		- Pivot AV renforcé	Photo 1
		- Pivot AR renforcé	Photo 2
		- Bielle de crémaillère renforcée	Photo 3
		- Arbre de transmission longitudinal renforcé	Photo 4
		- Tube de transmission longitudinal renforcé	Photo 5
		- Colonne de direction	Photo 6



Marque  
Make

PEUGEOT

Modèle  
Model

205 T 16

N° Homol.

B 262

PHOTOS / PHOTOS

N° Ext.

04 / 02 V0

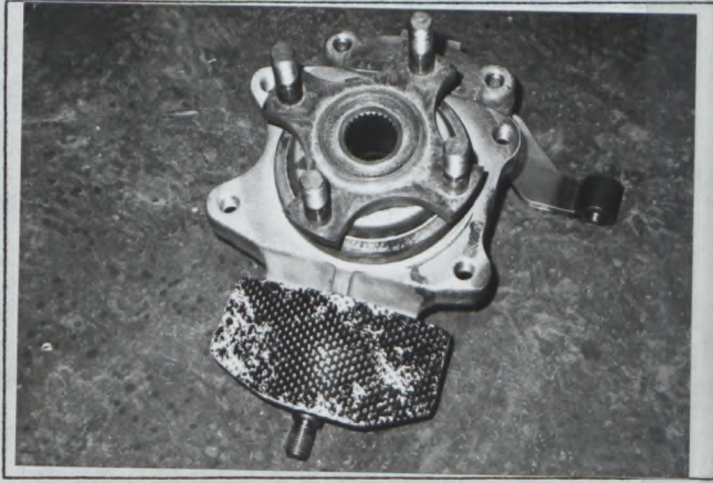

Photo 1

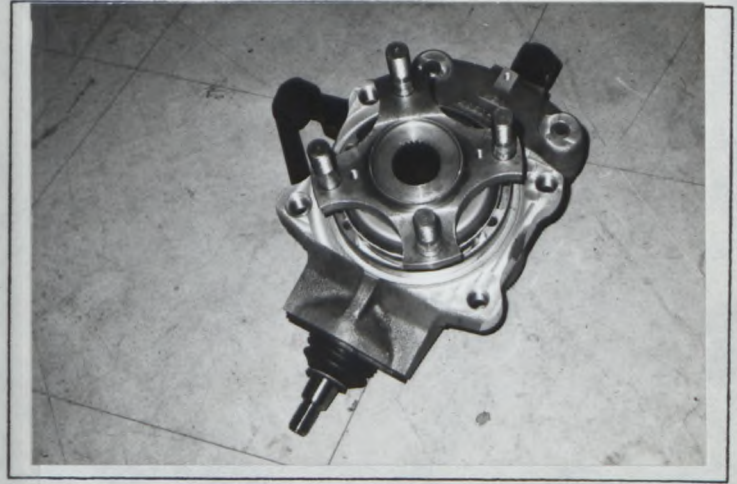

Photo 2



Photo 3



Photo 4



Photo 5



Photo 6





# FEDERATION INTERNATIONALE DU SPORT AUTOMOBILE

Homologation N°

B 262

Extension N°

05 - 03 VO

FICHE D'EXTENSION A L'HOMOLOGATION OFFICIELLE FISA  
FORM OF EXTENSION TO THE OFFICIAL FISA HOMOLOGATION

ET Evolution normale du type: dès le numéro de châssis  
Normal evolution of the type: as from chassis number \_\_\_\_\_

VF Variante de fourniture / Supply variant

VO Variante option / Option variant

ER Errata / Erratum

Homologation valable dès le  
Homologation valid as from \_\_\_\_\_

01 JAN. 1985

en groupe  
in group \_\_\_\_\_ B

Constructeur  
Manufacturer \_\_\_\_\_ PEUGEOT

Modèle et type  
Model and type \_\_\_\_\_ 205 TURBO 16

Page ou ext. Page or ext.	Art. Art.	Description Description	PHOTO 1	PHOTO 3
			Avant / Front	Arrière / Rear
		e) Nombre de cylindres par roue: Number of cylinders per wheel:	4	4
		e1) Alésage Bore	de 38,1 à 41,2 mm	de 38,1 à 41,2 mm
		f) Freins à tambours: Drum brakes:		
		(1) Diamètre intérieur Interior diameter	_____ mm (± 1.5 mm)	_____ mm (± 1.5 mm)
		(2) Nombre de mâchoires par roue. Number of shoes per wheel	_____	_____
		(3) Surface de freinage Braking surface	_____ cm <sup>2</sup>	_____ cm <sup>2</sup>
		(4) Largeur des garnitures Width of the shoes	_____ mm	_____ mm
		g) Freins à disques: Disc brakes:		
		g1) Nombre de sabots par roue Number of pads per wheel	_____	_____
		g2) Nombre d'étriers par roue Number of calipers per wheel	_____	_____
			AV / Front	AR / Rear
		g3) Matériau des étriers Caliper material	alu	alu
		g4) Epaisseur maximale du disque Maximum disc thickness	de 25,8 à 28 mm	de 25,8 à 28 mm
		g5) Diamètre extérieur du disque Exterior diameter of the disc	de 278 à 300 mm (± 1 mm)	de 278 à 300 mm (± 1 mm)
		g6) Diamètre extérieur de frottement des sabots Exterior diameter of the shoe's rubbing surface	de 278 à 300 mm	de 278 à 300 mm
		g7) Diamètre intérieur de frottement des sabots Interior diameter of the shoe's rubbing surface	de 184 à 195 mm	de 184 à 195 mm
		g8) Longueur hors-tout des sabots Overall length of the shoes	126,5 mm	126,5 mm
		g9) Disques ventilés Vented disc	oui/yes	oui/yes
		g10) Surface de freinage par roue Braking surface per wheel	de 682 à 816 cm <sup>2</sup>	de 682 à 816 cm <sup>2</sup>



*Signature*

Marque PEUGEOT  
Make \_\_\_\_\_

Modèle 205 T 16  
Model \_\_\_\_\_

N° Homol. B 262

PHOTOS / PHOTOS

N° Ext. 05 - 03 V0

PHOTO 1

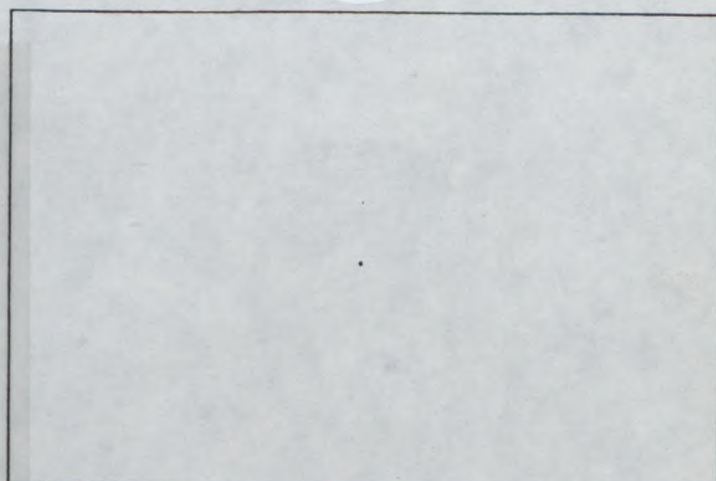
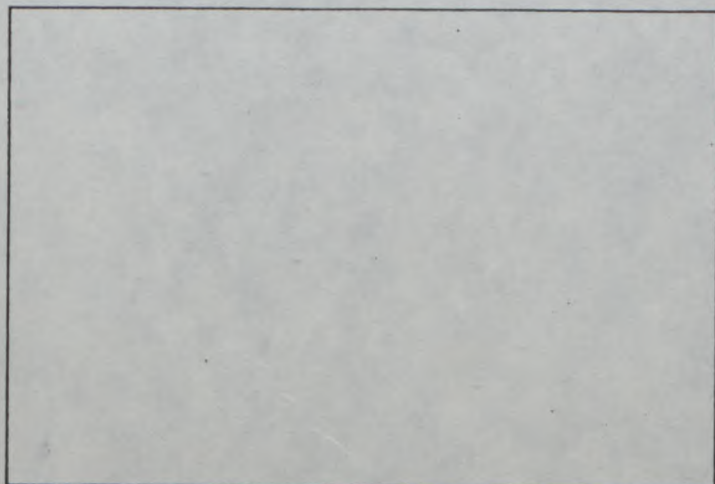
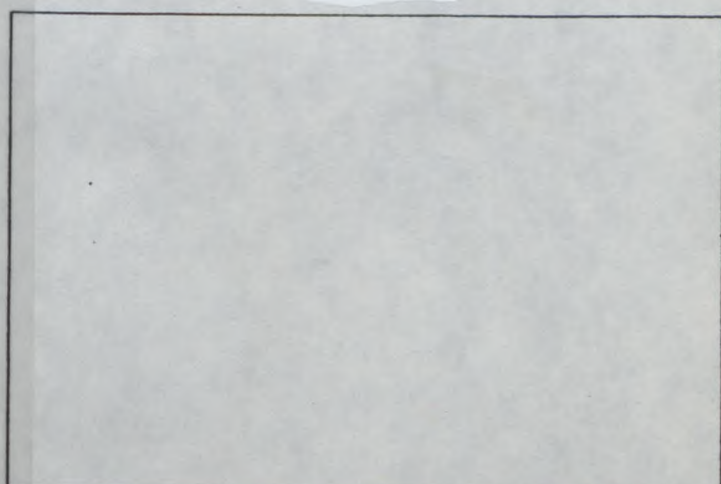

PHOTO 3







# FEDERATION INTERNATIONALE DU SPORT AUTOMOBILE

Homologation N°

B 262

Extension N°

06 - 04 VO

FICHE D'EXTENSION A L'HOMOLOGATION OFFICIELLE FISA  
FORM OF EXTENSION TO THE OFFICIAL FISA HOMOLOGATION

ET Evolution normale du type: dès le numéro de châssis  
Normal evolution of the type: as from chassis number \_\_\_\_\_

VF Variante de fourniture / Supply variant

VO Variante option / Option variant

ER Errata / Erratum

Homologation valable dès le  
Homologation valid as from

01 JAN. 1985

en groupe  
in group

B

Constructeur  
Manufacturer

PEUGEOT

Modèle et type  
Model and type

205 T16

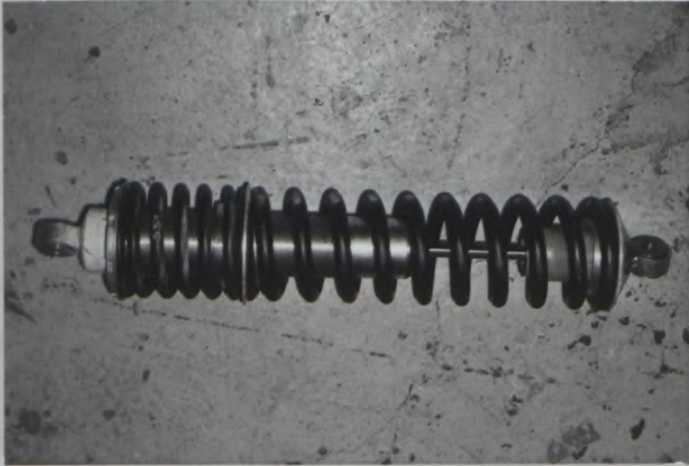
Page ou ext. Page or ext	Art. Art	Description Description
		<p>Amortisseur AV avec 2 ressorts</p> 





# FEDERATION INTERNATIONALE DU SPORT AUTOMOBILE

Homologation N°

B 262

Extension N°

07 - 02 FR

FICHE D'EXTENSION A L'HOMOLOGATION OFFICIELLE FISA  
FORM OF EXTENSION TO THE OFFICIAL FISA HOMOLOGATION

- ET** Evolution normale du type: dès le numéro de châssis  
Normal evolution of the type: as from chassis number \_\_\_\_\_
- VF** Variante de fourniture / Supply variant
- VO** Variante option / Option variant
- ER** Errata / Erratum

Homologation valable dès le 01 JAN. 1985 en groupe B  
Homologation valid as from \_\_\_\_\_ in group \_\_\_\_\_

Constructeur PEUGEOT Modèle et type 205 Turbo 16  
Manufacturer \_\_\_\_\_ Model and type \_\_\_\_\_

Page ou ext. Page or ext	Art. Art	Description Description
02/01 ET	334	e4 cote A 54,7 au lieu de 51





# FEDERATION INTERNATIONALE DU SPORT AUTOMOBILE

Homologation N°

B 262

Extension N°

08 - 05 VO

FICHE D'EXTENSION A L'HOMOLOGATION OFFICIELLE FISA  
FORM OF EXTENSION TO THE OFFICIAL FISA HOMOLOGATION

- ES** Evolution sportive du type / Sporting evolution of the type
- ET** Evolution normale du type / Normal evolution of the type
- VF** Variante de fourniture / Supply variant
- VO** Variante option / Option variant
- ER** Errata / Erratum

Homologation valable dès le 01 AVR. 1985 en groupe B  
Homologation valid as from \_\_\_\_\_ in group \_\_\_\_\_

Constructeur PEUGEOT Modèle et type 205 TURBO 16  
Manufacturer \_\_\_\_\_ Model and type \_\_\_\_\_

Page ou ext. Page or ext.	Art. Art.	Description Description	
		- Carter sec Nombre de pompe 1 à 5 étages	Photo 1
		- Suspension AV Bras Inf. renforcé	Photo 2
		Bras Sup. renforcé	Photo 3
		- Suspension AR Bras Inf. renforcé	Photo 4
		Bras Sup. renforcé	Photo 6
		- Frein à main hydraulique Sans maitre-cylindre	Photo 9

*Signature*



Marque  
Make PEUGEOT

Modèle  
Model 205 TURBO 16

N° Homol. B 262

N° Ext. 08 - 05 V0

Page ou ext. Page or ext.	Art. Art.	Description Description	
		- Réservoir à essence 54 1 et 54 1	Photo 10 - 11
		- Réservoir essence 54 1 et 25 1	Photo 12 - 13
		- Brasse anti devers AV	Photo 14
		- Bielle de suspension AR	Photo 15
		- Maître cylindre AV $\phi$ de 17,78 à 22,20 m/m AR $\phi$ de 17,78 à 22,20 m/m	
		- Pivot AV renforcé	Photo 16
		- Pivot AR renforcé	Photo 17
		- Amortisseur de direction	Photo 18
		- Colonne de direction de sécurité	Photo 19
		- Toit ouvrant	Photo 20





# FEDERATION INTERNATIONALE DU SPORT AUTOMOBILE

Homologation N°

B 262

Extension N°

08 - 05 VO

## FICHE D'EXTENSION A L'HOMOLOGATION OFFICIELLE FISA FORM OF EXTENSION TO THE OFFICIAL FISA HOMOLOGATION

**ET** Evolution normale du type: dès le numéro de châssis  
Normal evolution of the type: as from chassis number \_\_\_\_\_

**VF** Variante de fourniture / Supply variant

**VO** Variante option / Option variant

**ER** Errata / Erratum

Homologation valable dès le  
Homologation valid as from \_\_\_\_\_

en groupe  
in group B

Constructeur  
Manufacturer PEUGEOT

Modèle et type  
Model and type 205 TURBO 16

Page ou ext. Page or ext.	Art. Art.	Description Description
		Frein inboard accolé au pont AV et AR et, ou frein outboard. Photo 21-22-23-24 Photo 21-22-23-24

	Avant / Front		Arrière / Rear	
e) Nombre de cylindres par roue: Number of cylinders per wheel:	4 à 8		4 à 8	
e1) Alésage Bore	de 38 à 42 mm		de 38 à 42 mm	
f) Freins à tambours: Drum brakes:				
f1) Diamètre intérieur Interior diameter	_____ mm (± 1.5 mm)		_____ mm (± 1.5 mm)	
f2) Nombre de mâchoires par roue Number of shoes per wheel	_____		_____	
f3) Surface de freinage Braking surface	_____ cm <sup>2</sup>		_____ cm <sup>2</sup>	
f4) Largeur des garnitures Width of the shoes	_____ mm		_____ mm	
g) Freins à disques: Disc brakes:				
g1) Nombre de sabots par roue Number of pads per wheel	2 à 4		2 à 4	
g2) Nombre d'étriers par roue Number of callipers per wheel	1 à 2		1 à 2	
g3) Matériau des étriers Caliper material	Alu + magnésium		Alu + magnésium	
g4) Epaisseur maximale du disque Maximum disc thickness	28,2 mm		28,2 mm	
g5) Diamètre extérieur du disque Exterior diameter of the disc	de 278 à 303 mm (± 1 mm)		de 278 à 303 mm (± 1 mm)	
g6) Diamètre extérieur de frottement des sabots Exterior diameter of the shoe's rubbing surface	de 277 à 302 mm		de 277 à 302 mm	
g7) Diamètre intérieur de frottement des sabots Interior diameter of the shoe's rubbing surface	de 184 à 205 mm		de 184 à 205 mm	
g8) Longueur hors-tout des sabots Overall length of the shoes	de 127 à 131 mm		de 127 à 131 mm	
g9) Disques ventilés Ventilated disc	oui/non yes/no		oui/non yes/no	
g10) Surface de freinage par roue Braking surface per wheel	de 682 à 772 cm <sup>2</sup>		de 682 à 772 cm <sup>2</sup>	



PHOTOS / PHOTOS

N° Ext. 08 - 05 VO

Photo 1

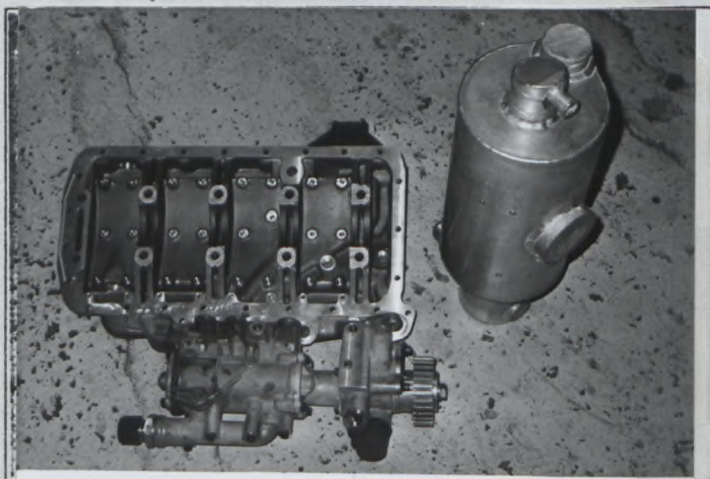

Photo 2



Photo 3



Photo 4



Photo 6



PHOTOS / PHOTOS

N° Ext. 08 - 05 VO

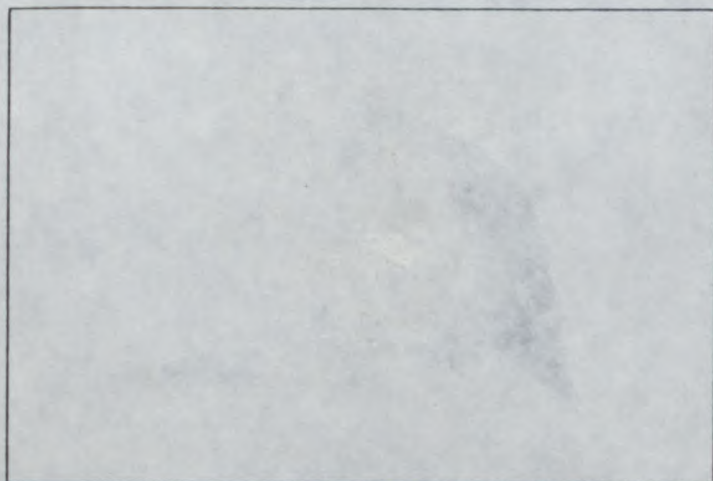

Photo 9

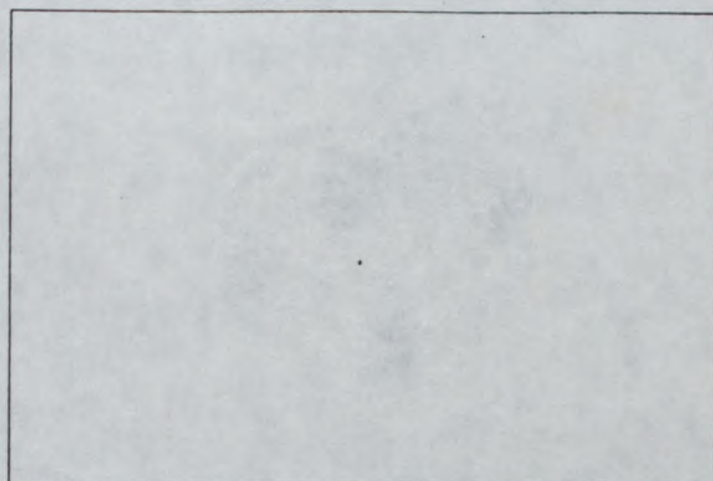

Photo 10



Photo 11

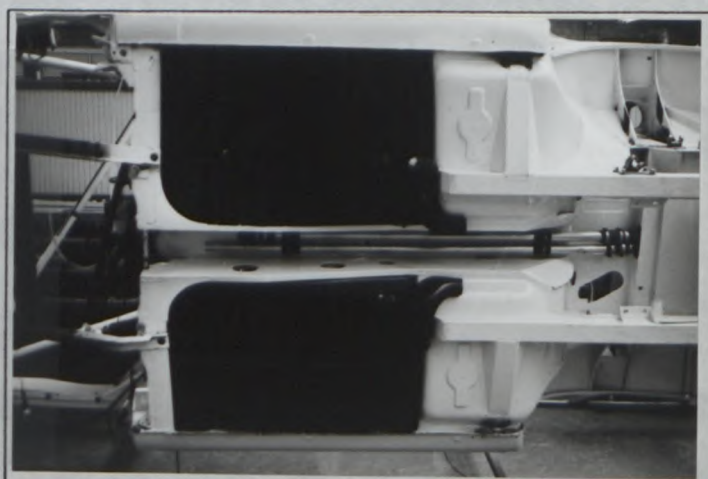

Photo 12



Marque

Make PEUGEOT

Modèle

Model 205 TURBO 16

N° Homol. B 262

PHOTOS / PHOTOS

N° Ext. 08 - 05 V0

Photo 13

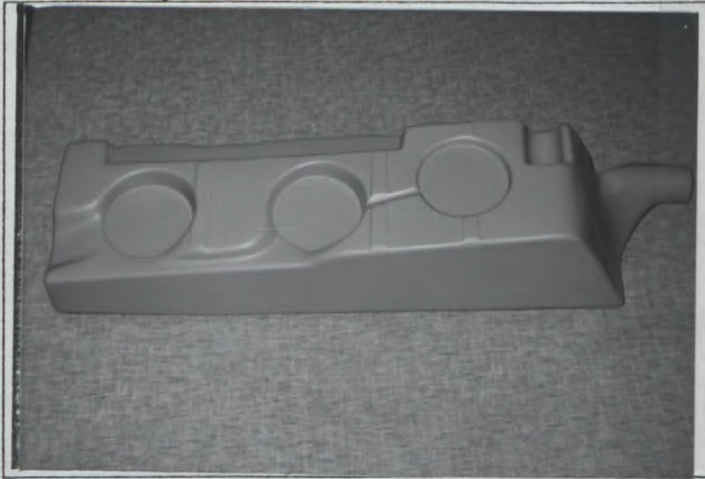

Photo 14

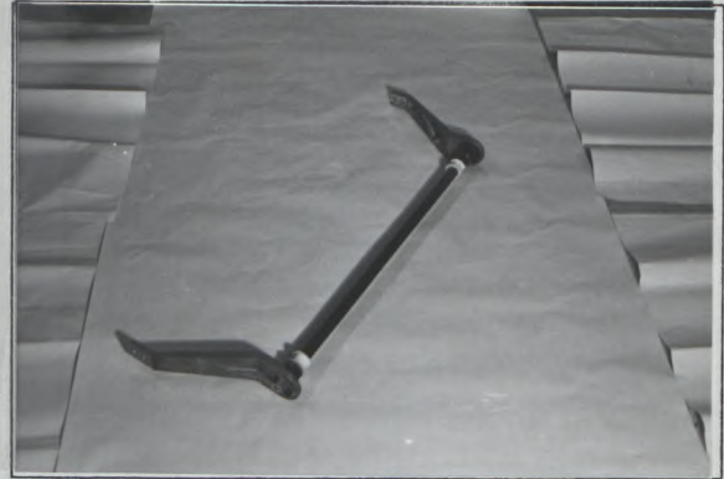

Photo 15



Photo 16

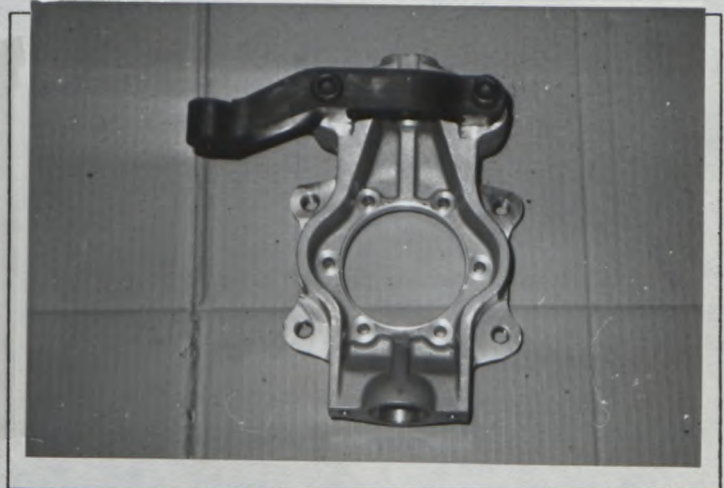

Photo 17

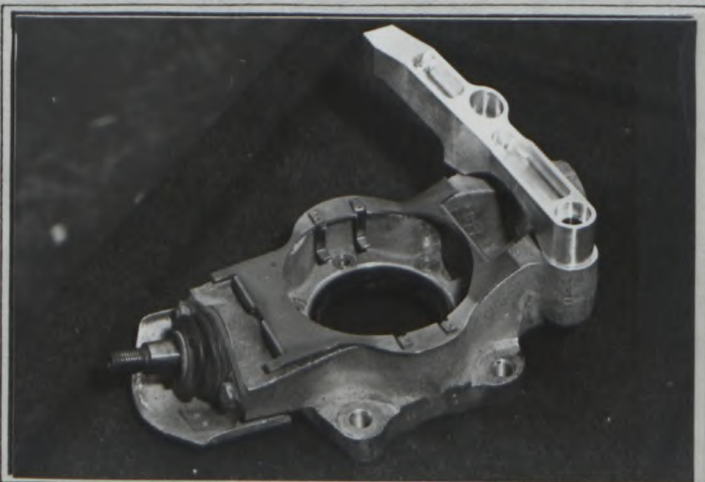

Photo 18





Marque

Make PEUGEOT

Modèle

Model 205 TURBO 16

N° Homol

B 262

PHOTOS / PHOTOS

N° Ext.

08-05V0

Photo 19



20



21

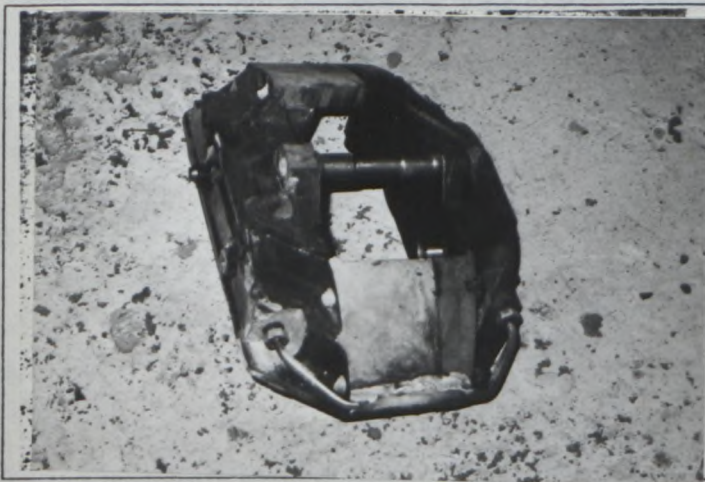

22

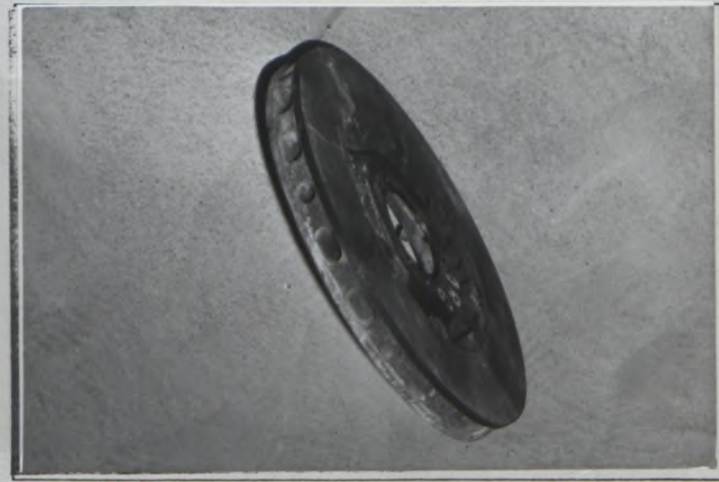

23



24

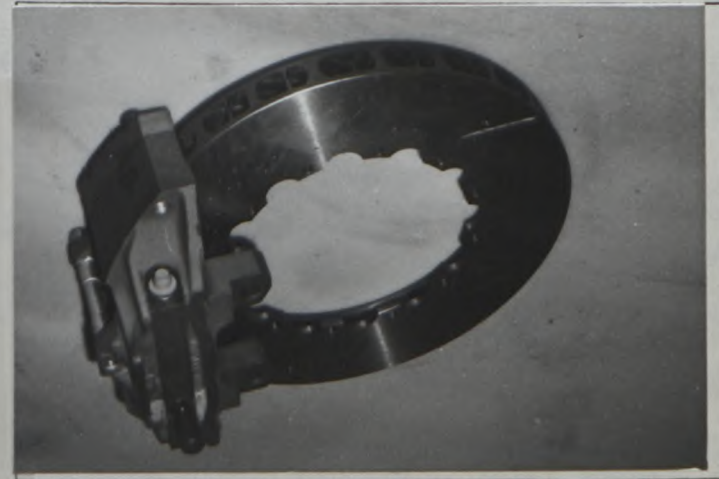



# FEDERATION INTERNATIONALE DU SPORT AUTOMOBILE

Homologation N°

B 262

Extension N°

09 - 02 ET

FICHE D'EXTENSION A L'HOMOLOGATION OFFICIELLE FISA  
FORM OF EXTENSION TO THE OFFICIAL FISA HOMOLOGATION

- ES** Evolution sportive du type / Sporting evolution of the type
- ET** Evolution normale du type / Normal evolution of the type
- VF** Variante de fourniture / Supply variant
- VO** Variante option / Option variant
- ER** Errata / Erratum

Homologation valable dès le 01 MAI 1985 en groupe B  
Homologation valid as from \_\_\_\_\_ in group \_\_\_\_\_

Constructeur PEUGEOT Modèle et type 205 TURBO 16  
Manufacturer \_\_\_\_\_ Model and type \_\_\_\_\_

Page ou ext. Page or ext.	Art. Art.	Description Description	
		- Culasse	Photo 1
		- Chambre de combustion	Photo 2
	319	- Poids du vilebrequin 15.960 g	
	320	- Poids minimum du volant moteur 3.230 g.	
	324	- Alimentation par injection	Photo 3
		- Débitmètre 8 sorties	
		d) dimension effective du point de mesure au papillon : $\varnothing$ 60,1	
	327	- Collecteur d'admission 8 éléments	Photo 4
		f) Longueur des soupapes 118,15 mm	
		- Dispositif de régulation de l'air d'admission à commande mécanique et asservie monté en amont de la turbine de compresseur	Photo 5
		- Régulation de la pression de suralimentation par détenteur ou asservie	Photo 6



Marque PEUGEOT Modèle 205 TURBO 16 N° Homol. B 262  
 Make Model N° Ext.

09 - 02 ET

Page ou ext. Page or ext.	Art. Art.	Description Description	
	328	- Nouveau turbo compresseur : voir feuille spécifique	
		- Echappement	
		a) Matériau de collecteur : tôle acier	Photo 7
		- Longueur des soupapes 116,9 mm	
		- Moteur Profil D	Photo 8
		Profil G	Photo 9
		- Injection d'eau pompe immergée	Photo 10
		- Moteur dans son compartiment	Photo 11
		- Arceau intégré à la carrosserie	Photo 12
		Matériau : acier 15 CD V6	
	104	* Matériaux du châssis : acier et composite	
		- Structure AV	Photo 13
		- Structure AR	Photo 14
		- Berceau AR	Photo 15
		- Nouveau plancher sous siège	Photo 16
		- Implantation radiateur d'eau + Echangeur	Photo 17
		- Voiture 3/4 AV	Photo 18
		- Voiture 3/4 AR	Photo 19
	203	- Largeur hors tout 1770 m/m	
		- Endroit de la mesure bouclier AV	
		- Largeur à l'axe AR 1737 mm	
	707	- Amortisseurs	
		c) principe de fonctionnement :	
		Hydraulique à refroidissement hydraulique.	



Marque  
Make PEUGEOT

Modèle  
Model 205 TURBO 16

N° Homol. B 262

N° Ext. 09-02 ET

Page ou ext. Page or ext.	Art. Art.	Description Description	
		- Nouveau carter et nouvelle fixation de pont AR.	Photo 20
		- Nouveau carter et nouvelle fixation de pont AV.	Photo 21
		- Nouvelle partie AR avec aileron réglable	Photo 22
		- Nouveau pare-choc AV avec lame réglable	Photo 23
		- Nouveau capot AV	Photo 24
		- Tirant côté moteur	Photo 25
		- Tirant côté boîte de vitesses	Photo 25
		- Diagonale caisse droite et gauche	Photo 26
		- Divers renforts de caisse	Photo 27-28- 29-30
		- Tirant moteur	Photo 31
		- Nouveau rapport boîte de vitesses (voir page spécifique)	
		- Tirant berceau caisse	Photo 32
		- Crémaillère de direction boîtier renforcé	Photo 33
		- Ouverture dans lunette arrière	Photo 22
		- Glace de porte avec ouverture et écope d'air	Photo 34





# FEDERATION INTERNATIONALE DU SPORT AUTOMOBILE

Homologation N°

B 262

Extension N°

09-02 ET

FICHE D'EXTENSION A L'HOMOLOGATION OFFICIELLE FISA  
FORM OF EXTENSION TO THE OFFICIAL FISA HOMOLOGATION

- ES** Evolution sportive du type / Sporting evolution of the type
- ET** Evolution normale du type / Normal evolution of the type
- VF** Variante de fourniture / Supply variant
- VO** Variante option / Option variant
- ER** Errata / Erratum

Homologation valable dès le \_\_\_\_\_ en groupe \_\_\_\_\_  
Homologation valid as from \_\_\_\_\_ in group \_\_\_\_\_ B

Constructeur PEUGEOT Modèle et type 205 TURBO 16  
Manufacturer \_\_\_\_\_ Model and type \_\_\_\_\_

Page ou ext. Page or ext.	Art. Art.	Description Description

e) Rapports  
Ratios

	Manuelle / Manual			Automatique / Automatic			B.V. suppl. / Additional G.B.		
	rappports ratio	nombre de dents / number of teeth	synchro.	rappports ratio	nombre de dents / number of teeth	synchro.	rappports ratio	nombre de dents / number of teeth	synchro.
1	2,923	38/13	X				2,533	38/15	X
2	1,944	35/18	X				1,789	34/19	X
3	1,407	38/27	X				1,357	38/28	X
4	1,129	35/31	X				1,129	35/31	X
5	0,969	32/33	X				0,961	25/26	X
AR/R	2,695	41/22/13					2,695	41/22/13	
Constante Constant									

f) Grille de vitesse  
Gear change gate

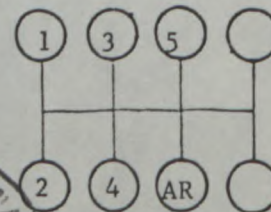
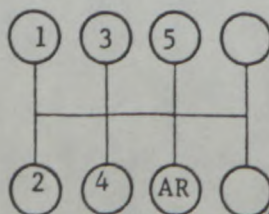

DESSINS / DRAWINGS

Moteur / Engine

- I Orifices d'admission de la culasse, face collecteur (tolérances sur dimensions: -2%, +4%)  
 Cylinderhead inlet ports, manifold side (tolerances on dimensions: -2%, +4%)

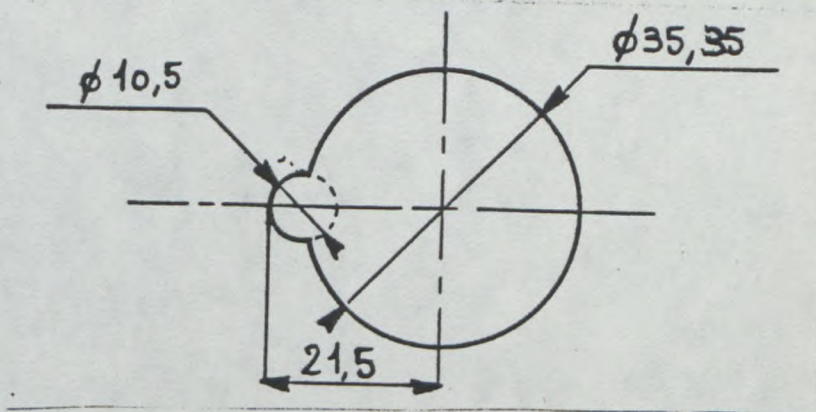

- II Orifices du collecteur d'admission, côté culasse (tolérances sur dimensions: -2%, +4%)  
 Inlet manifold ports, cylinderhead side (tolerances on dimensions: -2%, +4%)

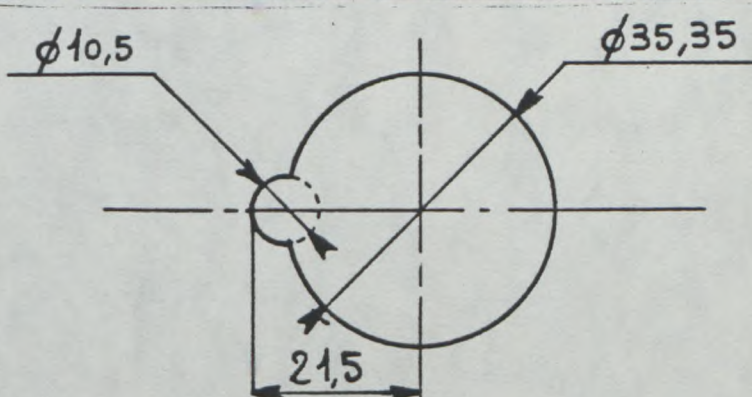

- III Orifices d'échappement de la culasse, face collecteur (tolérances sur dimensions: -2%, +4%)  
 Cylinderhead exhaust ports, manifold side (tolerances on dimensions: -2%, +4%)

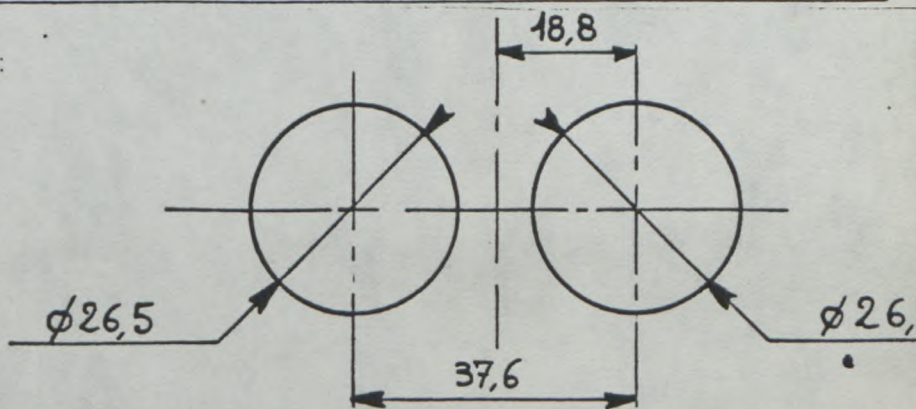

- IV Orifices du collecteur d'échappement, côté culasse (tolérances sur dimensions: -2%, +4%)  
 Exhaust manifold ports, cylinderhead side (tolerances on dimensions: -2%, +4%)

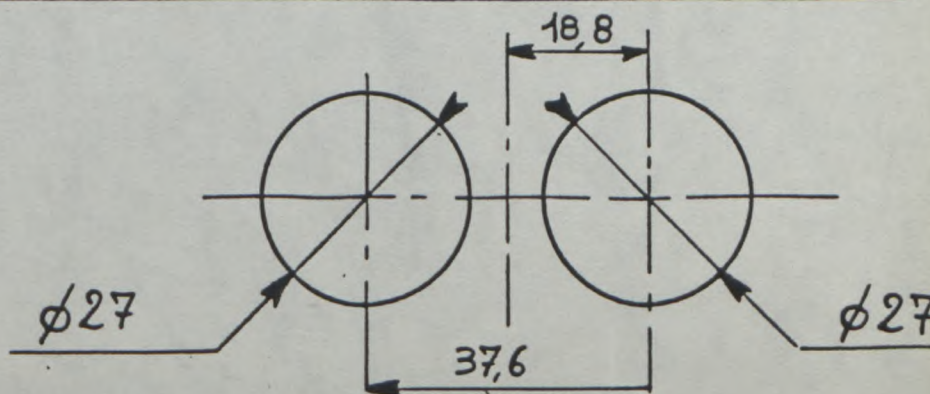

Marque PEUGEOT  
Make PEUGEOT

Modèle 205 TURBO 16  
Model 205 TURBO 16

N° Homol. B 262

PHOTOS / PHOTOS

N° Ext. 09-02 FT

Photo 1



Photo 2

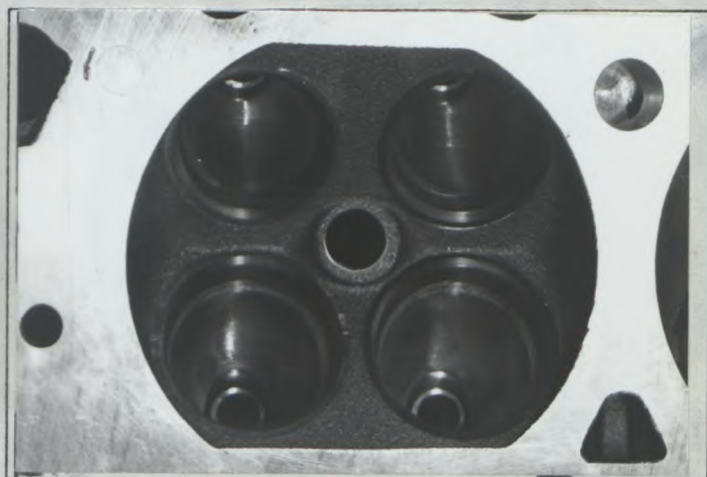

Photo 3

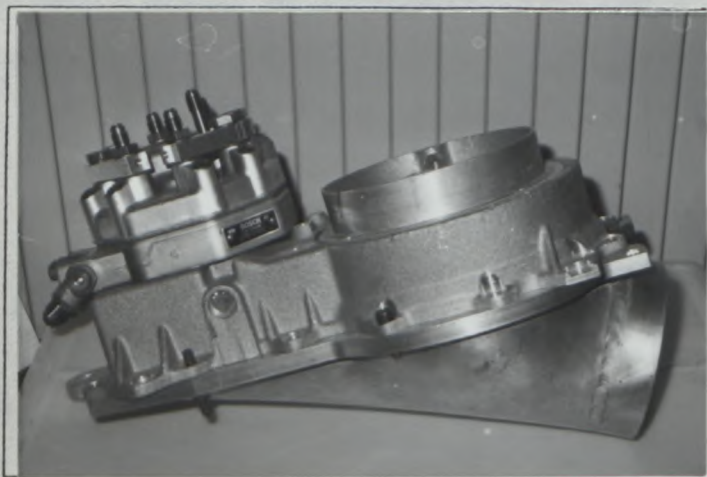

Photo 4

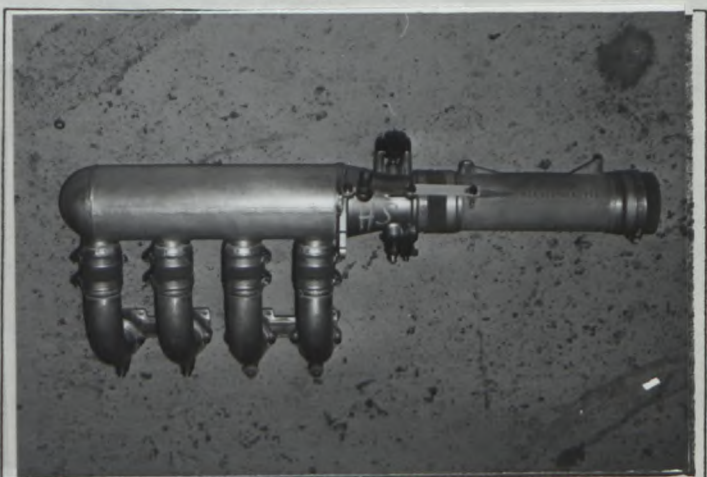

Photo 5

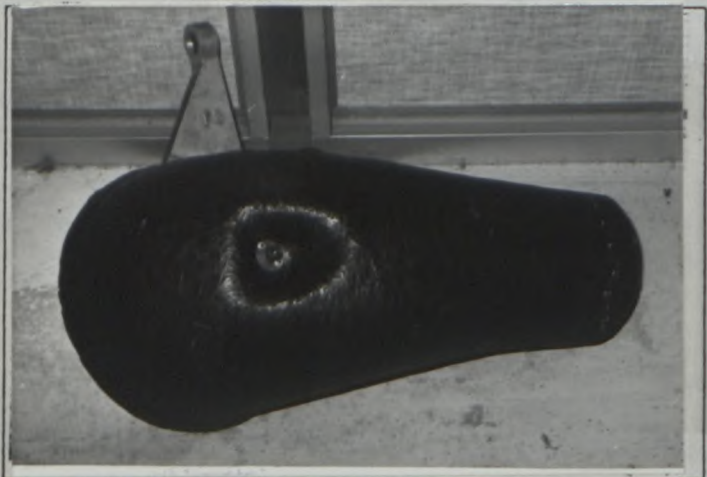

Photo 6



Marque  
Make PEUGEOT

Modèle  
Model 205 TURBO 16

N° Homol. B 262

PHOTOS / PHOTOS

N° Ext. 09 - 02 ET

Photo 7



Photo 8

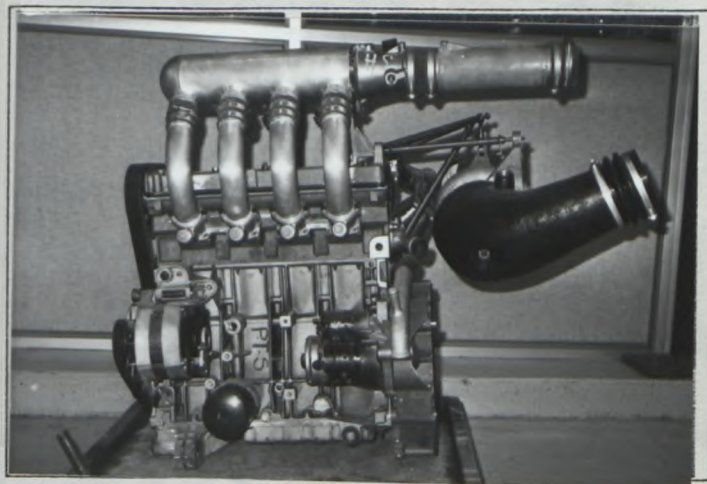

Photo 9

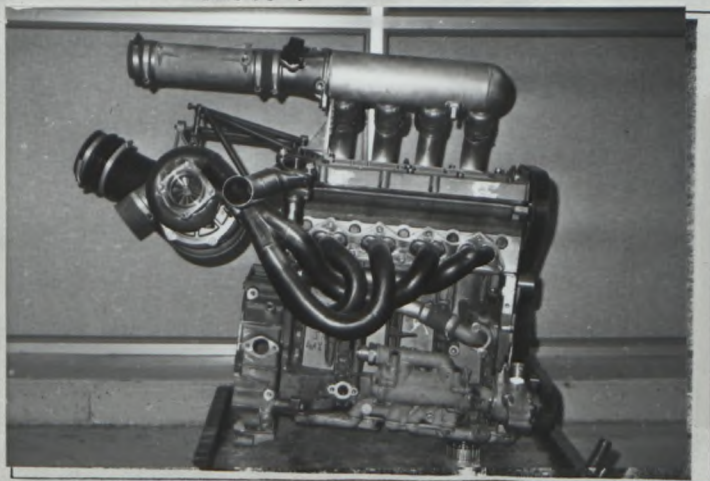

Photo 10

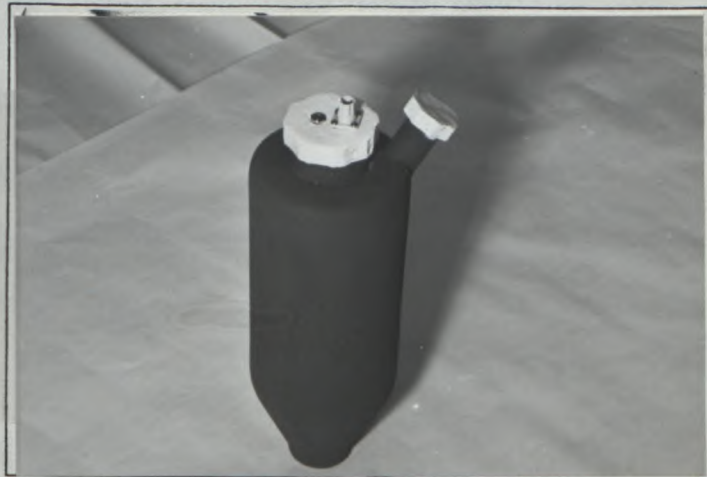

Photo 11

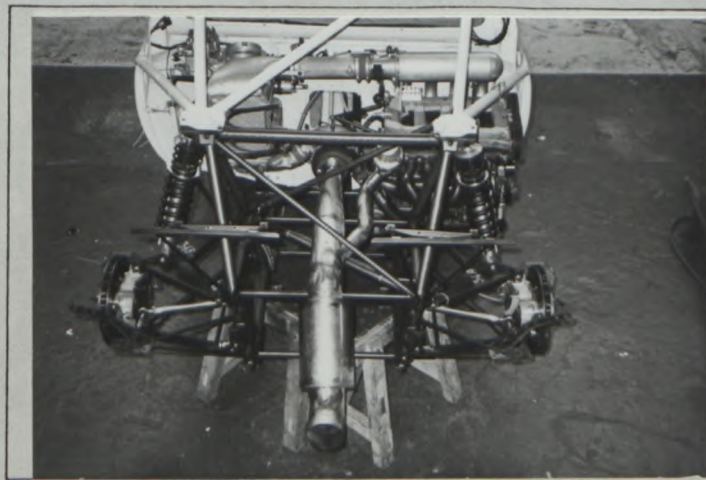

Photo 12





Marque  
Make PEUGEOT

Modèle  
Model 205 TURBO 16

N° Homol. B 262

PHOTOS / PHOTOS

N° Ext. 09-02 ET

Photo 13

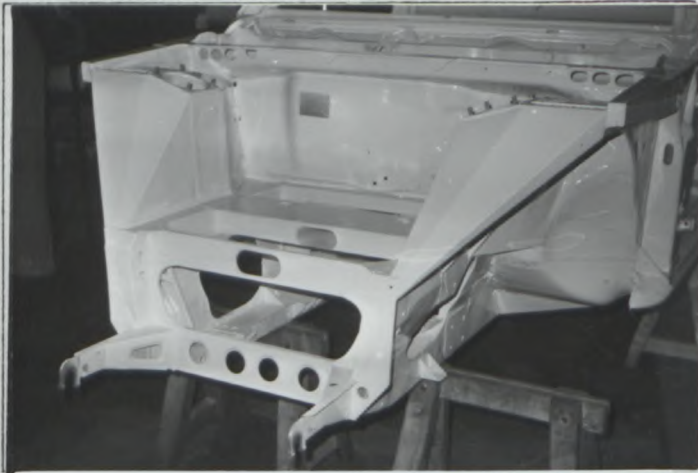

Photo 14

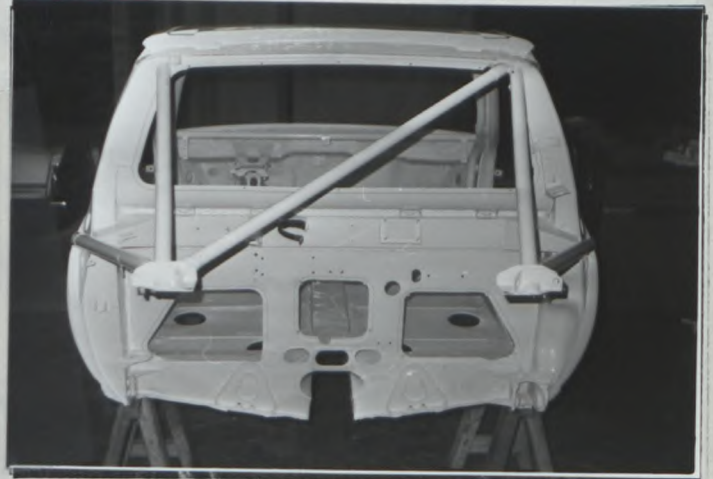

Photo 15

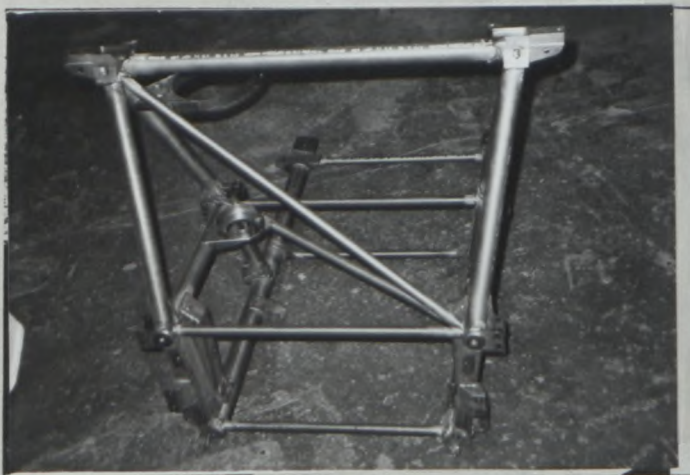

Photo 16



Photo 17

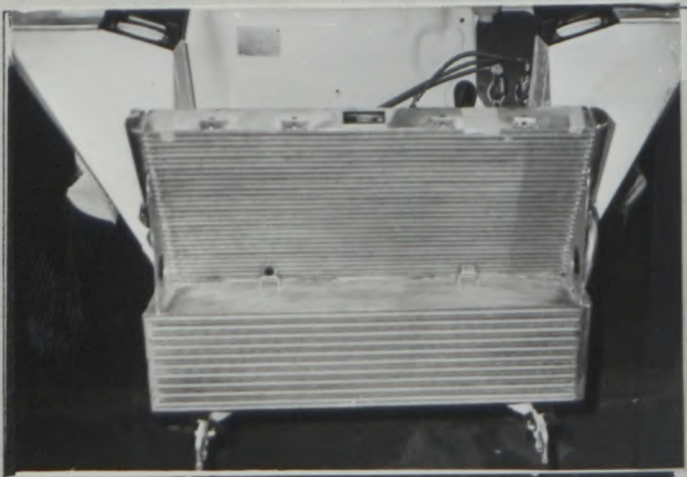

Photo 18



Marque PEUGEOT Modèle 205 TURBO 16 N° Homol. B 262  
Make Model N° Ext.

PHOTOS / PHOTOS

N° Ext. **09 - 02 FT**

Photo 19

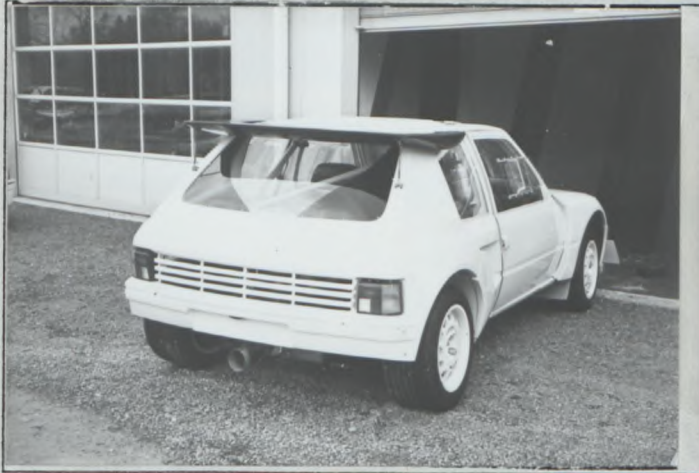

Photo 20

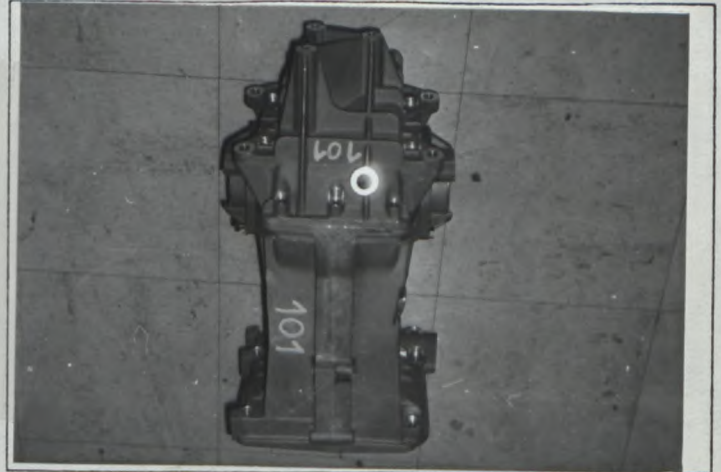

Photo 21

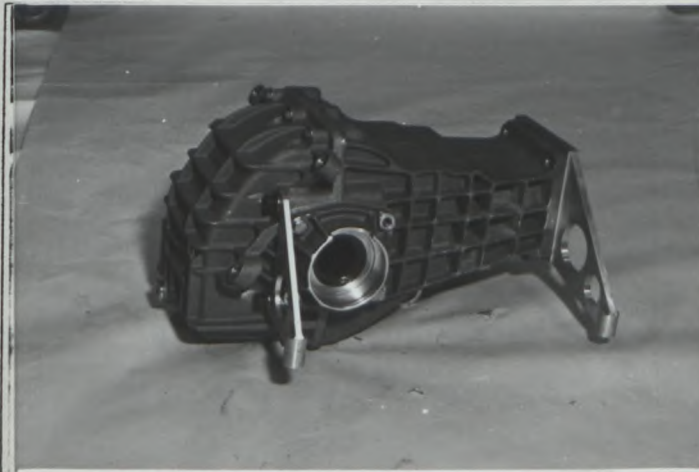

Photo 22



Photo 23



Photo 24



Marque  
Make PEUGEOT

Modèle  
Model 205 TURBO 16

N° Homol B 262

PHOTOS / PHOTOS

N° Ext 09-02 FT

25



26



27



28

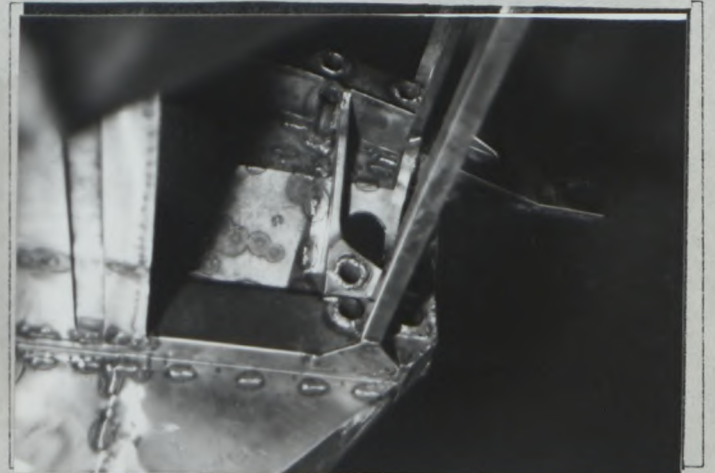

29



30



Marque PEUGEOT  
Make

Modèle 205 TURBO 16  
Model

N° Homol B 262

PHOTOS / PHOTOS

N° Ext. 09-02 ET

31



32



33



34





# FEDERATION INTERNATIONALE DU SPORT AUTOMOBILE

Homologation N°

B 262

09 - 02 FT

Groupe  
Group **A/B**

## FICHE D'HOMOLOGATION ADDITIONNELLE POUR MOTEURS SURALIMENTÉS PAR TURBOCOMPRESSEUR(S) ADDITIONAL HOMOLOGATION FORM FOR TURBO CHARGED ENGINES

Véhicule : Constructeur PEUGEOT Modèle et type 205 TURBO 16  
 Vehicle : Manufacturer PEUGEOT Model and type 205 TURBO 16

Homologation valable à partir du \_\_\_\_\_ en groupe B  
 Homologation valid as from \_\_\_\_\_ in group B

334. Suralimentation  
Turbocharging

a) Marque et type du turbo compresseur GARETT T 31  
 Make and type of the turbocharger \_\_\_\_\_

b) Carter de turbine :  
Turbine housing :

b1) Nombre d'entrées des gaz d'échappement 1  
 Number of exhaust gas entries \_\_\_\_\_

b2) Matériau FONTE  
 Material \_\_\_\_\_

c) Roue de turbine :  
Turbine wheel :

c1) Matériau ACIER  
 Material \_\_\_\_\_

c2) Nombre d'aubes 11  
 Number of blades \_\_\_\_\_

c3) Hauteur(s) d'une aube + 0,30  
 Height(s) of blade 24,08 / - 0,20 mm

c4) Préciser les cotes A,B,C, selon le schéma suivant :  
 Indicate the dimensions A, B, C, according the following sketch :

$$A = \frac{56,62}{+0,1} \text{ mm}$$

$$B = \frac{9,74}{-0,7} \text{ mm}$$

$$C = \frac{64,95}{+0,3} \text{ mm}$$

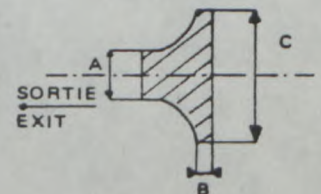

d) Carter de compression :  
Impeller housing :

d1) Nombre d'entrée d'air (mélange) 1  
 Number of air entries (gas) \_\_\_\_\_

d2) Matériau Alliage d'aluminium  
 Material \_\_\_\_\_

e) Roue de compression  
Impeller wheel :

e2) Nombre d'aubes 7+7 e3) Hauteur(s) d'une aube + 0,3  
 Number of blades \_\_\_\_\_ Height(s) of blade 31,19 / - 0,2 mm

e4) Préciser les cotes A, B, C selon le schéma suivant :  
 Indicate the dimensions A, B, C, according to the following sketch,

$$A = \frac{54,92}{+0,1} \text{ mm}$$

$$B = \frac{7,4}{-0,7} \text{ mm}$$

$$C = \frac{75,95}{-0,3} \text{ mm}$$

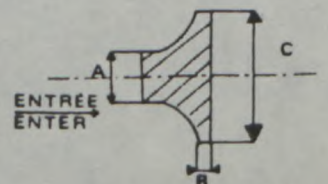

09-02 FT

f) Régulation de la pression :  
 Pressure regulation :

f1) Type de régulation de la pression :  by-pass  soupape de décharge  autre cas  
 Type of pressure adjustment :  by-pass  relief valve  other case

f2) Préciser le type de la soupape et son contrôle Waste gate réglable  
 Indicate the type of the valve and its control \_\_\_\_\_

g) Système d'échappement :  
 Exhaust system :

Dimensions intérieures de l'éventuel tuyau d'échappement entre le collecteur d'échappement et le turbocompresseur (dessin)  
 Internal dimensions of the eventual exhaust pipes between exhaust manifold and turbocharger (sketch)

///

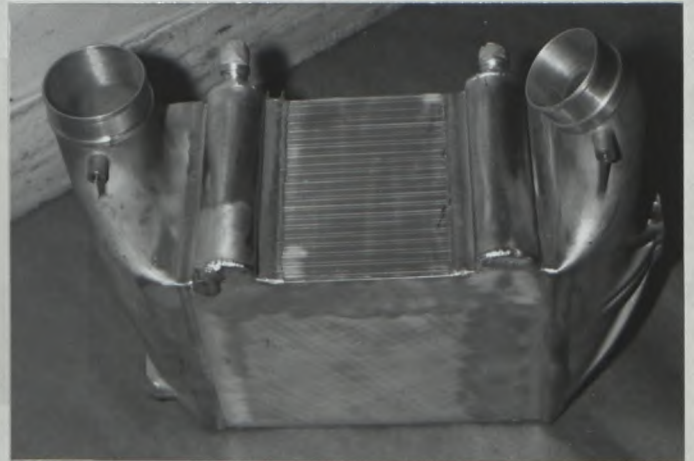

h) Refroidissement de l'air d'admission : oui/~~NON~~  
 Cooling of intake air : yes/~~NO~~

PHOTOS

k) Vue de dessus du turbo compresseur  
 Plan view of turbocharger

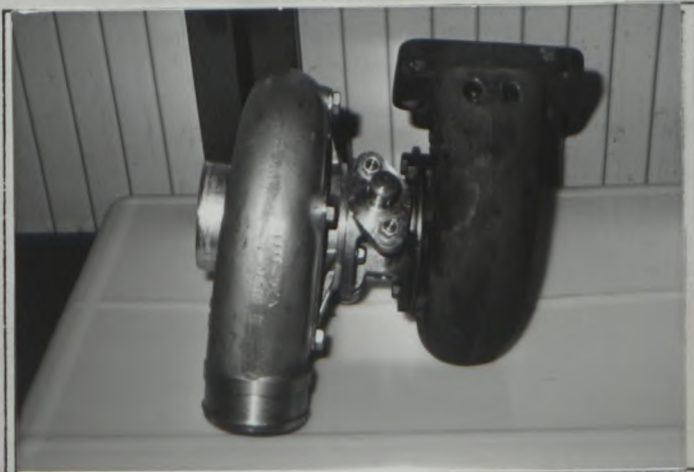

L) Vue de face du turbo compresseur  
 Front view of turbocharger



09-02 FT

M) Vue de côté du turbocompresseur  
Side view of turbocharger

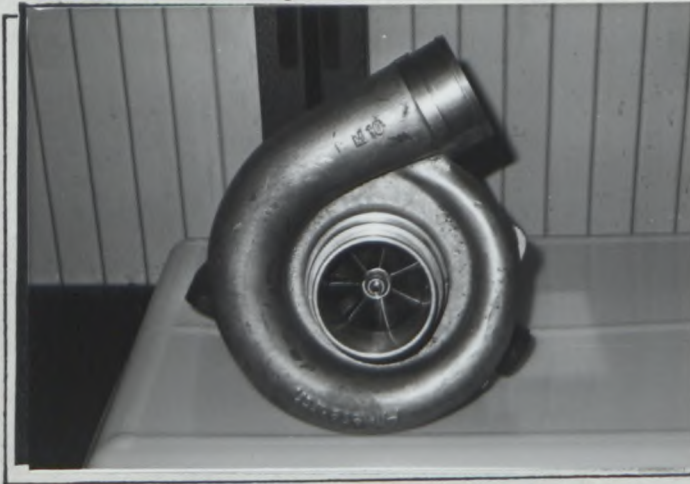

N) Carter de turbine du turbocompresseur  
Turbine housing of turbocharger

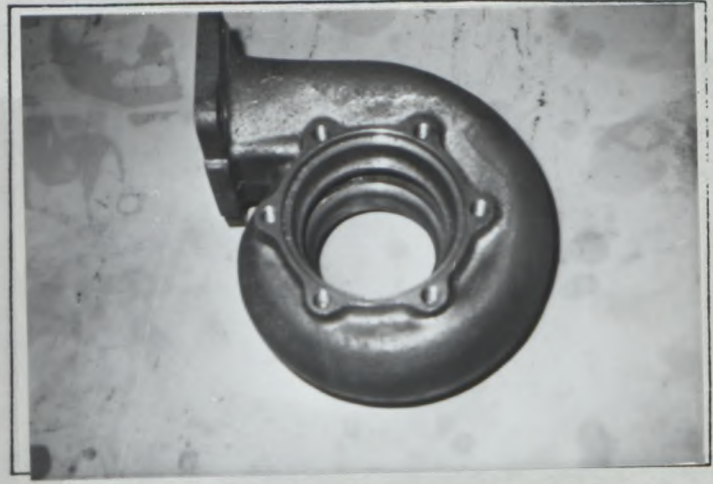

O) Soupape et montage du by-pass du turbocompresseur  
Valve and by-pass installation of turbocharger



P) Eventuel échappement entre le collecteur d'échappement et le turbocompresseur.  
Eventual exhaust pipes between the exhaust manifold and the turbocharger.

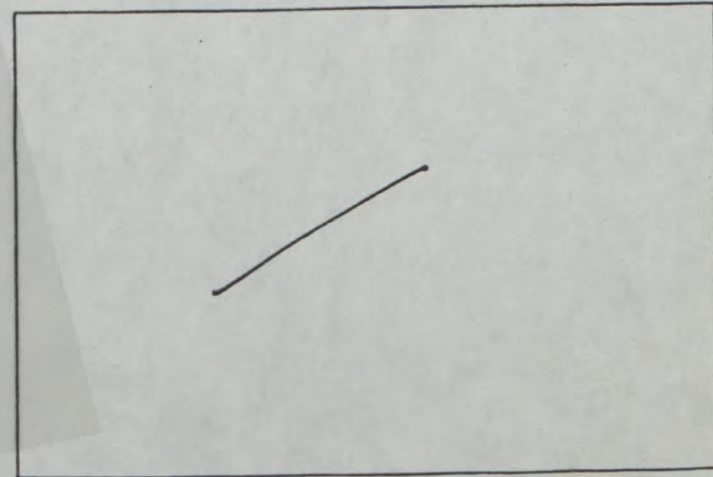

Q) Carter de compression du turbocompresseur  
Impeller housing of turbocharger

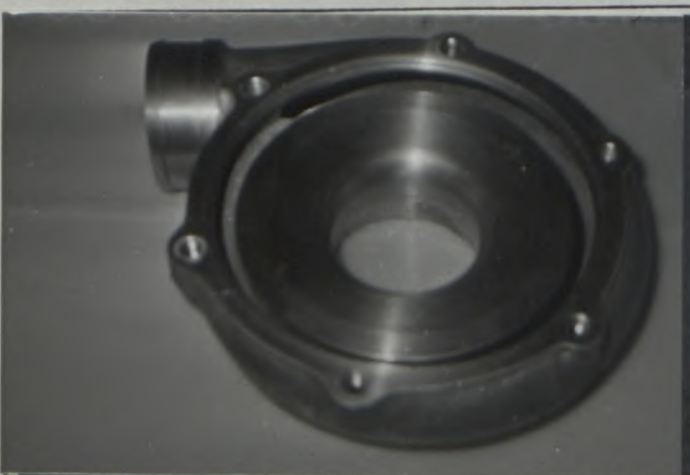

09 - 02 FT

DESSINS / DRAWINGS

V) Entrée des gaz d'échappement dans le carter de turbine du turbocompresseur  
Exhaust gas entry in the turbine housing of turbocharger.

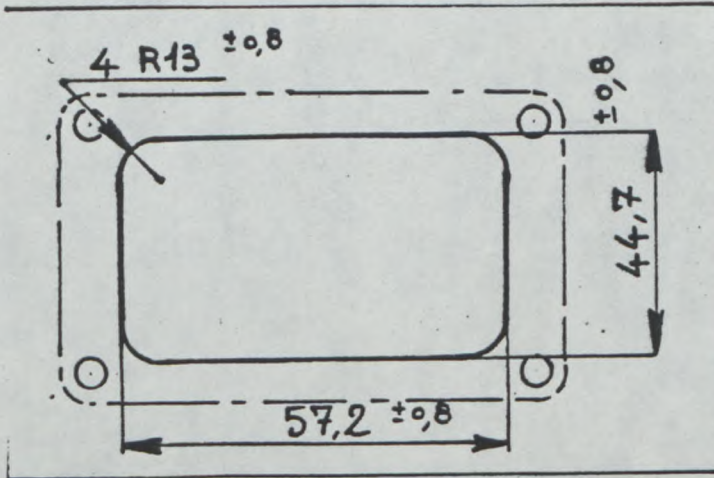

VI) Sortie des gaz d'échappement du carter de turbine du turbocompresseur.  
Exhaust gas exit of the turbine housing of turbocharger.

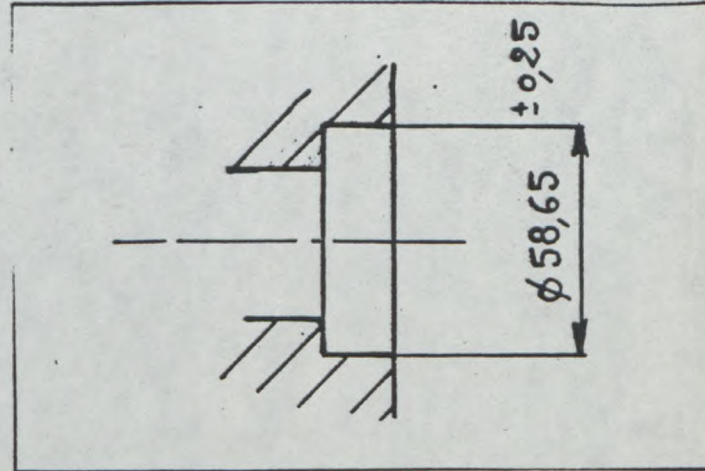

VII) Entrée de l'air (mélange) dans le carter de compression du turbocompresseur.  
Air (gas) entry in the impeller housing of the turbocharger

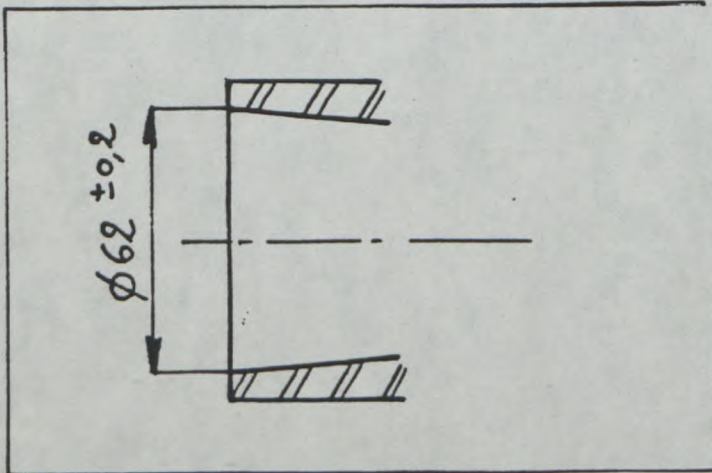

VIII) Sortie de l'air (mélange) du carter de compression du turbocompresseur.  
Air (gas) exit of the impeller housing of the turbocharger

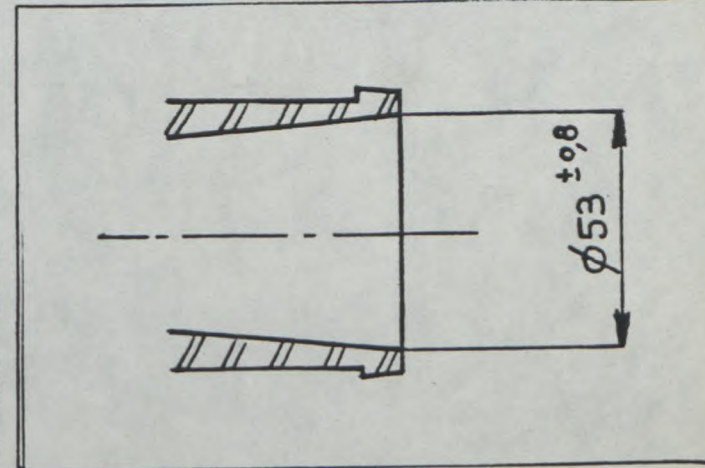

IX. Dispositif réglant la pression de suralimentation  
Device regulating the turbocharging pressure.

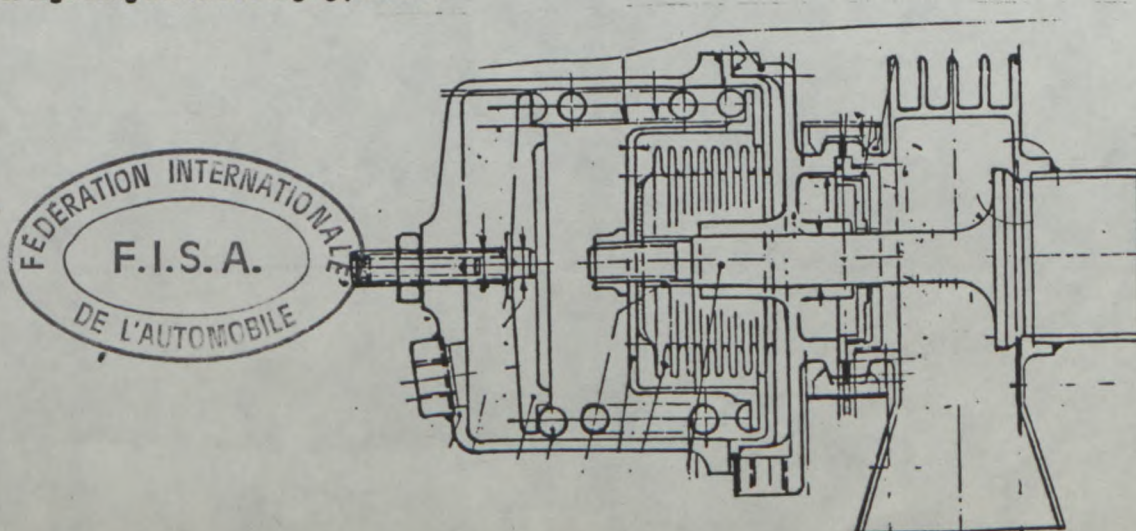





# FEDERATION INTERNATIONALE DU SPORT AUTOMOBILE

Homologation N°

B 262

Extension N°

10-06 VO

FICHE D'EXTENSION A L'HOMOLOGATION OFFICIELLE FISA  
FORM OF EXTENSION TO THE OFFICIAL FISA HOMOLOGATION

VO Variante option / Option variant

Homologation valable dès le 01 MAI 1985 en groupe B  
Homologation valid as from \_\_\_\_\_ in group \_\_\_\_\_

Constructeur de la voiture PEUGEOT Modèle et type 205 TURBO 16  
Manufacturer of the car \_\_\_\_\_ Model and type \_\_\_\_\_

## ARCEAU / CAGE DE SECURITE

## ROLLBAR / ROLLCAGE

ARCEAU INTEGRE  
A LA CARROSSERIE

Arceau principal

Entretoise  
longitudinale/diagonale  
Longitudinal/diagonal  
strut

Arceau avant

Main rollbar

Front rollbar

Fabricant de l'arceau  
Rollbar manufacturer

PEUGEOT TALBOT SPORT

Matériau

15 CD V6

15 /CD V6

15 CD V6

Material

Diamètre extérieur

\_\_\_\_\_ mm

\_\_\_\_\_ mm / \_\_\_\_\_ mm

\_\_\_\_\_ mm

Exterior diameter

Epaisseur de paroi

\_\_\_\_\_ mm

\_\_\_\_\_ mm / \_\_\_\_\_ mm

\_\_\_\_\_ mm

Wall thickness

Limite élastique

\_\_\_\_\_ kg/mm<sup>2</sup>\_\_\_\_\_ kg/mm<sup>2</sup> / \_\_\_\_\_ kg/mm<sup>2</sup>\_\_\_\_\_ kg/mm<sup>2</sup>

Elastic limit

Résistance à la traction

\_\_\_\_\_ kg/mm<sup>2</sup>\_\_\_\_\_ kg/mm<sup>2</sup> / \_\_\_\_\_ kg/mm<sup>2</sup>\_\_\_\_\_ kg/mm<sup>2</sup>

Tensile strength

Poids total y-compris les fixations

Total weight including fixings \_\_\_\_\_ kg

Arceau/cage complet(e) hors de la voiture

Complete rollbar/rollcage outside the car

*Signature*



Nous attestons que le présent arceau / la présente cage de sécurité répond aux dispositions de l'Annexe J de la FIA, en particulier en ce qui concerne ses implantations, ses connexions et ses résistances aux contraintes.

We certify that the present rollbar/rollcage complies with the conditions of the FIA Appendix J, in particular with regard to its attachments, its connections and its stress resistances.

Signature du représentant du constructeur du véhicule  
Signature of the car manufacturer representative

J. TODT

*Jean Todt*

Marque  
Make PEUGEOT

Modèle  
Model 205 TURBO 16

N° Homol. B 262

PHOTOS OU DESSINS DES FIXATIONS SUR LA COQUE :  
PHOTOS OR DRAWINGS OF THE ATTACHMENTS ON THE BODY :

N° Ext. 10 - 06 V0





# FEDERATION INTERNATIONALE DU SPORT AUTOMOBILE

Homologation N°

B 262

Extension N°

11 - 07 VO

FICHE D'EXTENSION A L'HOMOLOGATION OFFICIELLE FISA  
FORM OF EXTENSION TO THE OFFICIAL FISA HOMOLOGATION

- ES** Evolution sportive du type / Sporting evolution of the type
- ET** Evolution normale du type / Normal evolution of the type
- VF** Variante de fourniture / Supply variant
- VO** Variante option / Option variant
- ER** Errata / Erratum

- 1 JUIL. 1985

Homologation valable dès le

Homologation valid as from

en groupe

in group

B

Constructeur

Manufacturer

PEUGEOT

Modèle et type

Model and type

205 TURBO 16

Page ou ext. Page or ext.	Art. Art.	Description Description	
	804	Rapport de direction 17,28/1 - 15,70/1	
		c) Servo assistance oui	Photo 1
		- Anti rebond avant	Photo 2
		- Anti rebond arrière	Photo 3
		- Bras de suspension AV renforcé inférieur	Photo 4
		supérieur	Photo 5
		- Bras de suspension AR renforcé inférieur	Photo 6
		supérieur	Photo 7
		- Bielle renforcée de suspension AR	Photo 8
		- Bielle de crémaillère renforcée	Photo 9
		- Transmission renforcée	Photo 10
		- Colonne de direction	Photo 11



*Signature*

Marque PEUGEOT  
Make PEUGEOT

Modèle 205 TURBO 16  
Model 205 TURBO 16

N° Homol. B 262

PHOTOS / PHOTOS

N° Ext. 11-07 V0

Photo 1

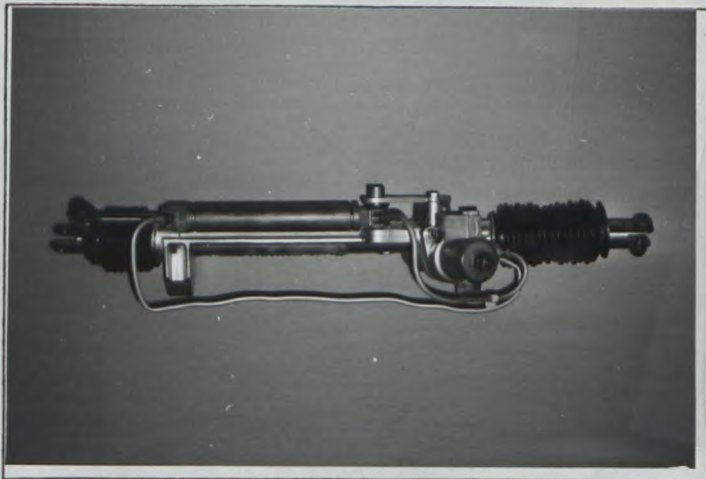

Photo 2

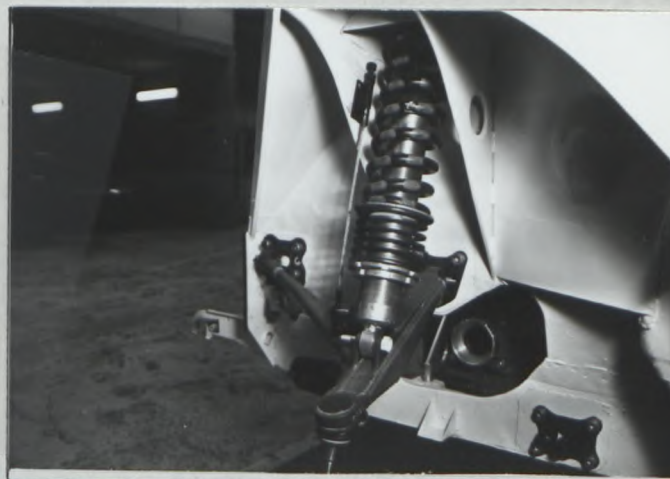

Photo 3

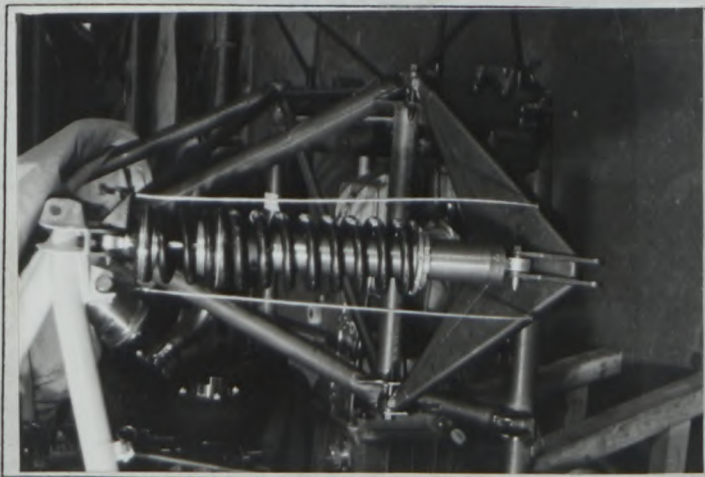

Photo 4



Photo 5

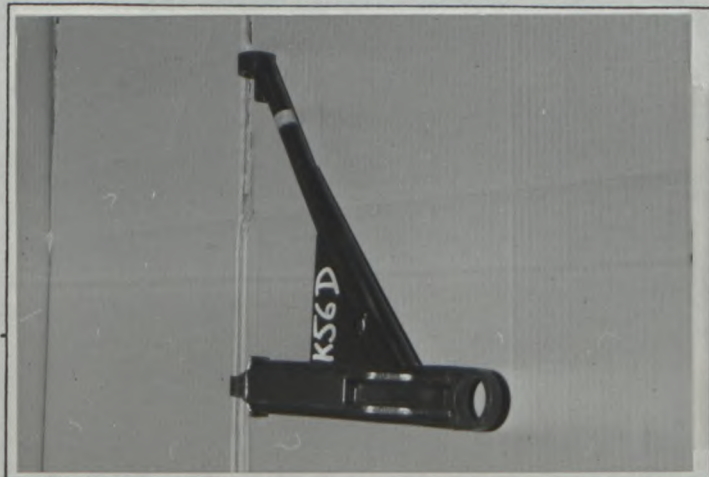
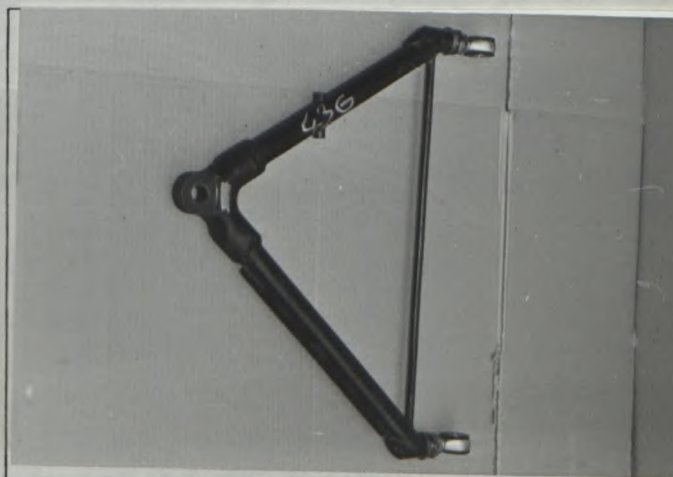

Photo 6



Marque

Make PEUGEOT

Modèle

Model 205 TURBO 16

N° Homol. B 262

PHOTOS / PHOTOS

N° Ext. 11-07 V0

Photo 7

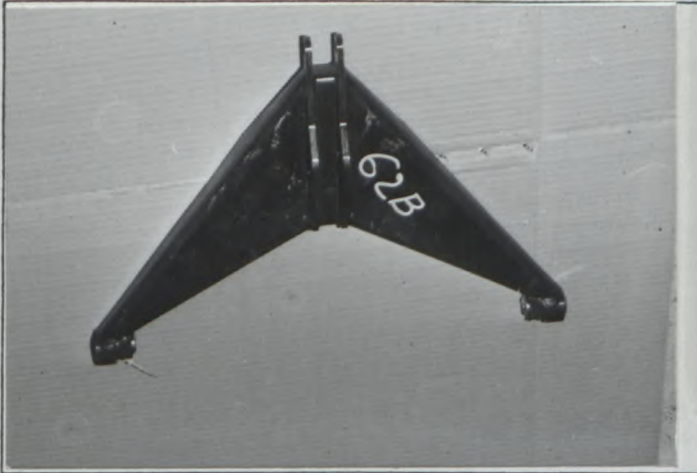

Photo 8

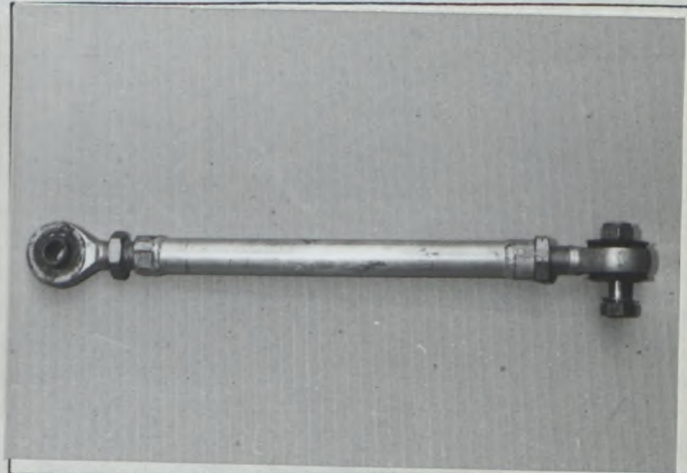

Photo 9



Photo 10

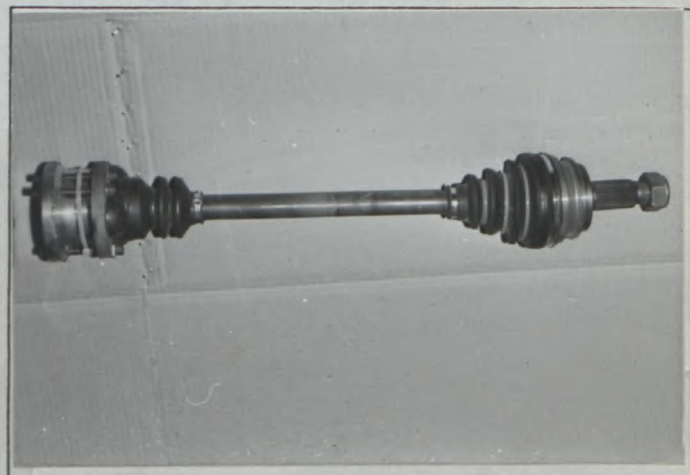
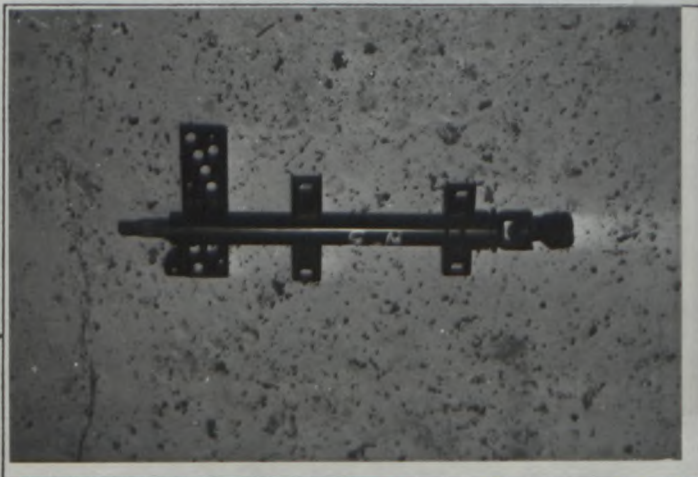

Photo 11





# FEDERATION INTERNATIONALE DU SPORT AUTOMOBILE

Homologation N°

B 262

Extension N°

**12 - 0 8 VO**

FICHE D'EXTENSION A L'HOMOLOGATION OFFICIELLE FISA  
FORM OF EXTENSION TO THE OFFICIAL FISA HOMOLOGATION

- ES** Evolution sportive du type / Sporting evolution of the type
- ET** Evolution normale du type / Normal evolution of the type
- VF** Variante de fourniture / Supply variant
- VO** Variante option / Option variant
- ER** Errata / Erratum

Homologation valable dès le  
Homologation valid as from

**- 1 OCT. 1985**

en groupe  
in group **B**

Constructeur  
Manufacturer **PEUGEOT**

Modèle et type  
Model and type **205 TURBO 16**

Page ou ext. Page or ext.	Art. Art.	Description Description
		<p>- Carter sec</p> <p>Nombre de pompes 2</p> <ul style="list-style-type: none"> <li>. 1 à 1 étage</li> <li>. 1 à 4 étages</li> </ul>

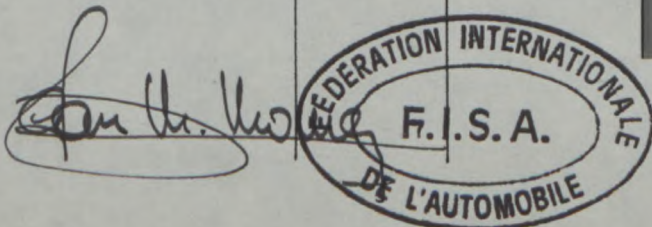
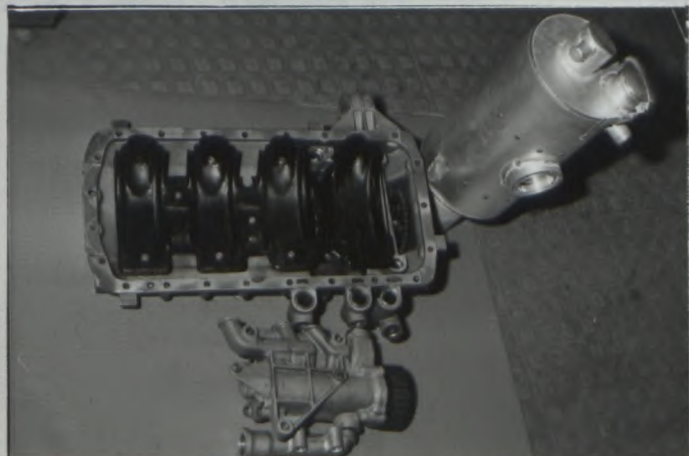



# FEDERATION INTERNATIONALE DU SPORT AUTOMOBILE

Homologation N°

B262

Extension N°

13 - 09 VO

FICHE D'EXTENSION A L'HOMOLOGATION OFFICIELLE FISA  
FORM OF EXTENSION TO THE OFFICIAL FISA HOMOLOGATION

ET Evolution normale du type: dès le numéro de châssis  
Normal evolution of the type: as from chassis number \_\_\_\_\_

VF Variante de fourniture / Supply variant

VO Variante option / Option variant

ER Errata / Erratum

Homologation valable dès le  
Homologation valid as from \_\_\_\_\_

- 1 OCT. 1985

en groupe B  
in group \_\_\_\_\_

Constructeur  
Manufacturer PEUGEOT

Modèle et type  
Model and type 265 Turbo 16

Page ou ext. Page or ext.	Art. Art.	Description Description	photo 1	photo 1																																
		e) Nombre de cylindres par roue: Number of cylinders per wheel. e1) Alésage Bore f) Freins à tambours: Drum brakes. f1) Diamètre intérieur Interior diameter f2) Nombre de mâchoires par roue Number of shoes per wheel f3) Surface de freinage Braking surface f4) Largeur des garnitures Width of the shoes g) Freins à disques Disc brakes g1) Nombres de sabots par roue Number of pads per wheel g2) Nombre d'étriers par roue Number of calipers per wheel g3) Matériau des étriers Caliper material g4) Epaisseur maximale du disque Maximum disc thickness g5) Diamètre extérieur du disque Exterior diameter of the disc g6) Diamètre extérieur de frottement des sabots Exterior diameter of the shoe's rubbing surface g7) Diamètre intérieur de frottement des sabots Interior diameter of the shoe's rubbing surface g8) Longueur hors-sabot des sabots Overall length of the shoes g9) Disques ventilés Ventilated disc g10) Surface de freinage par roue Braking surface per wheel	<table border="1"> <thead> <tr> <th>Avant / Front</th> <th>Arrière / Rear</th> </tr> </thead> <tbody> <tr> <td>4 à 8</td> <td>4 à 8</td> </tr> <tr> <td>32 à 42 mm</td> <td>32 à 42 mm</td> </tr> <tr> <td>_____ mm (± 1.5 mm)</td> <td>_____ mm (± 1.5 mm)</td> </tr> <tr> <td>_____ cm<sup>2</sup></td> <td>_____ cm<sup>2</sup></td> </tr> <tr> <td>_____ mm</td> <td>_____ mm</td> </tr> <tr> <td>2 à 4</td> <td>2 à 4</td> </tr> <tr> <td>1 à 2</td> <td>1 à 2</td> </tr> </tbody> </table>	Avant / Front	Arrière / Rear	4 à 8	4 à 8	32 à 42 mm	32 à 42 mm	_____ mm (± 1.5 mm)	_____ mm (± 1.5 mm)	_____ cm <sup>2</sup>	_____ cm <sup>2</sup>	_____ mm	_____ mm	2 à 4	2 à 4	1 à 2	1 à 2	<table border="1"> <thead> <tr> <th>AV / Front</th> <th>AR / Rear</th> </tr> </thead> <tbody> <tr> <td>alu+magnesium</td> <td>alu+magnesium</td> </tr> <tr> <td>_____ mm</td> <td>_____ mm</td> </tr> <tr> <td>_____ mm (± 1 mm)</td> <td>_____ mm (± 1 mm)</td> </tr> <tr> <td>_____ mm</td> <td>_____ mm</td> </tr> <tr> <td>_____ mm</td> <td>_____ mm</td> </tr> <tr> <td>oui/non yes/no</td> <td>oui/non yes/no</td> </tr> <tr> <td>_____ cm<sup>2</sup></td> <td>_____ cm<sup>2</sup></td> </tr> </tbody> </table>	AV / Front	AR / Rear	alu+magnesium	alu+magnesium	_____ mm	_____ mm	_____ mm (± 1 mm)	_____ mm (± 1 mm)	_____ mm	_____ mm	_____ mm	_____ mm	oui/non yes/no	oui/non yes/no	_____ cm <sup>2</sup>	_____ cm <sup>2</sup>
Avant / Front	Arrière / Rear																																			
4 à 8	4 à 8																																			
32 à 42 mm	32 à 42 mm																																			
_____ mm (± 1.5 mm)	_____ mm (± 1.5 mm)																																			
_____ cm <sup>2</sup>	_____ cm <sup>2</sup>																																			
_____ mm	_____ mm																																			
2 à 4	2 à 4																																			
1 à 2	1 à 2																																			
AV / Front	AR / Rear																																			
alu+magnesium	alu+magnesium																																			
_____ mm	_____ mm																																			
_____ mm (± 1 mm)	_____ mm (± 1 mm)																																			
_____ mm	_____ mm																																			
_____ mm	_____ mm																																			
oui/non yes/no	oui/non yes/no																																			
_____ cm <sup>2</sup>	_____ cm <sup>2</sup>																																			



*Signature*





# FEDERATION INTERNATIONALE DU SPORT AUTOMOBILE

Homologation N°

B 262

Extension N°

14 - 10 VO

FICHE D'EXTENSION A L'HOMOLOGATION OFFICIELLE FISA  
FORM OF EXTENSION TO THE OFFICIAL FISA HOMOLOGATION

VO Variante option / Option variant

Homologation valable dès le - 1 NOV. 1985 en groupe B  
Homologation valid as from \_\_\_\_\_ in group \_\_\_\_\_

Constructeur de la voiture PEUGEOT Modèle et type 205 TURBO 16  
Manufacturer of the car \_\_\_\_\_ Model and type \_\_\_\_\_

## ARCEAU / CAGE DE SECURITE

## ROLLBAR / ROLLCAGE

Arceau principal

Entretoise  
longitudinale/diagonale  
Longitudinal/diagonal  
strut

Arceau avant

Main rollbar

Front rollbar

Fabricant de l'arceau  
Rollbar manufacturer

PEUGEOT TALBOT SPORT

Matériau  
Material

ALZ-NMG1

ALZ NMG1 /

ALZ NMG1

Diamètre extérieur  
Exterior diameter

40 mm

40 mm / 40 mm

40 mm

Epaisseur de paroi  
Wall thickness

3 mm

3 mm / 3 mm

3 mm

Limite élastique  
Elastic limit

29 kg/mm<sup>2</sup>29 kg/mm<sup>2</sup> / 29 kg/mm<sup>2</sup>29 kg/mm<sup>2</sup>

Résistance à la traction  
Tensile strength

29 kg/mm<sup>2</sup>25 kg/mm<sup>2</sup> / 25 kg/mm<sup>2</sup>29 kg/mm<sup>2</sup>

Poids total y-compris les fixations  
Total weight including fixings

11 kg

Arceau/cage complet (e) hors de la voiture  
Complete rollbar/rollcage outside the car

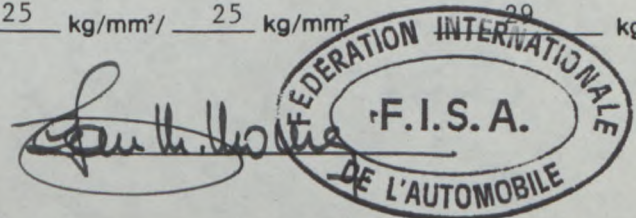

Nous attestons que le présent arceau / la présente cage de sécurité répond aux dispositions de l'Annexe J de la FIA, en particulier en ce qui concerne ses implantations, ses connexions et ses résistances aux contraintes.

We certify that the present rollbar/rollcage complies with the conditions of the FIA Appendix J, in particular with regard to its attachments, its connections and its stress resistances.

Signature du représentant du constructeur du véhicule  
Signature of the car manufacturer representative

J. TODT



Marque PEUGEOT . Modèle 205 TURBO 16 N° Homol. B 262  
Make PEUGEOT . Model 205 TURBO 16 N° Ext. 14 - 10 VO

PHOTOS OU DESSINS DES FIXATIONS SUR LA COQUE :  
PHOTOS OR DRAWINGS OF THE ATTACHMENTS ON THE BODY :

N° Ext. 14 - 10 VO

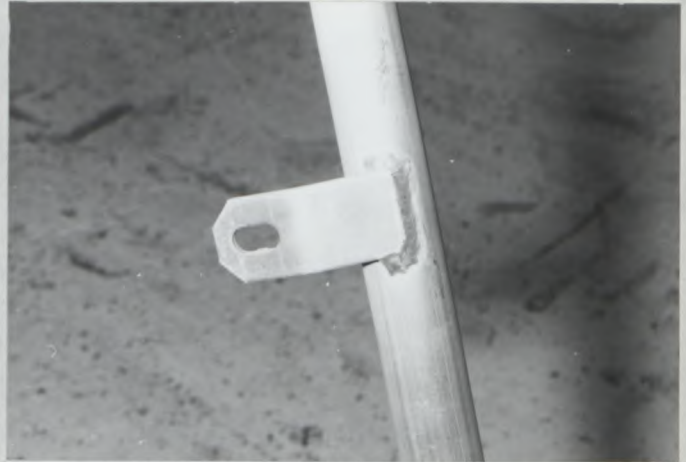



# FEDERATION INTERNATIONALE DU SPORT AUTOMOBILE

Homologation

B 262

Extension

**15 - 03 ER**

FICHE D'EXTENSION A L'HOMOLOGATION OFFICIELLE FISA  
FORM OF EXTENSION TO THE OFFICIAL FISA HOMOLOGATION

- ES** Evolution sportive du type / Sporting evolution of the type
- ET** Evolution normale du type / Normal evolution of the type
- VF** Variante de fourniture / Supply variant
- VO** Variante option / Option variant
- ER** Errata / Erratum

Homologation valable dès le - 1 NOV. 1985 en groupe B  
Homologation valid as from \_\_\_\_\_ in group \_\_\_\_\_

Constructeur PEUGEOT Modèle et type 205 T 16  
Manufacturer \_\_\_\_\_ Model and type \_\_\_\_\_

Page ou ext. Page or ext.	Art. Art.	Description Description
		<p>09 - 02 ET</p> <p>Sur feuille spécifique turbo dessin VI sortie des gaz d'échappement du carter de turbine cote <math>\phi 64,05 \pm 0,25</math> au lieu de <math>58,65 \pm 0,25</math></p>

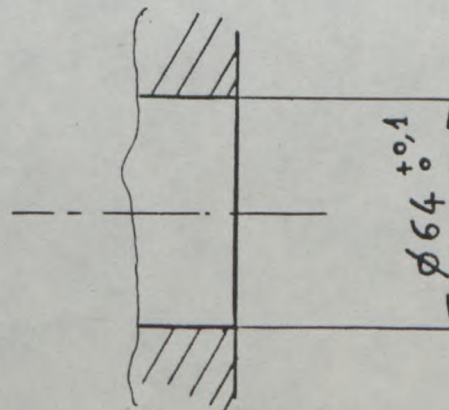

*Santh. Houng*



# FEDERATION INTERNATIONALE DU SPORT AUTOMOBILE

Homologation N°

B 262

Extension N°

16-11 VO

FICHE D'EXTENSION A L'HOMOLOGATION OFFICIELLE FISA  
FORM OF EXTENSION TO THE OFFICIAL FISA HOMOLOGATION

 VO Variante option / Option variant

Homologation valable dès le - 1 JAN. 1986 en groupe B  
Homologation valid as from \_\_\_\_\_ in group \_\_\_\_\_

Constructeur de la voiture PEUGEOT Modèle et type 205 TURBO 16  
Manufacturer of the car \_\_\_\_\_ Model and type \_\_\_\_\_

## ARCEAU / CAGE DE SECURITE

## ROLLBAR / ROLLCAGE

Arceau principal

Entretoise  
longitudinale/diagonale  
Longitudinal/diagonal  
strut

Arceau avant

Main rollbar

Front rollbar

Fabricant de l'arceau Rollbar manufacturer	PEUGEOT TALBOT SPORT		
Matériau Material	ALZ-NMG1	ALZ-NMG1 /	ALZ-NMG1
Diamètre extérieur Exterior diameter	40 mm	40 mm / 40 mm	40 mm
Epaisseur de paroi Wall thickness	3 mm	3 mm / 3 mm	3 mm
Limite élastique Elastic limit	29 kg/mm <sup>2</sup>	29 kg/mm <sup>2</sup> / 29 kg/mm <sup>2</sup>	29 kg/mm <sup>2</sup>
Résistance à la traction Tensile strength	29 kg/mm <sup>2</sup>	25 kg/mm <sup>2</sup> / 25 kg/mm <sup>2</sup>	29 kg/mm <sup>2</sup>
Poids total y-compris les fixations Total weight including fixings	11 kg		

Arceau/cage complet(e) hors de la voiture  
Complete rollbar/rollcage outside the car

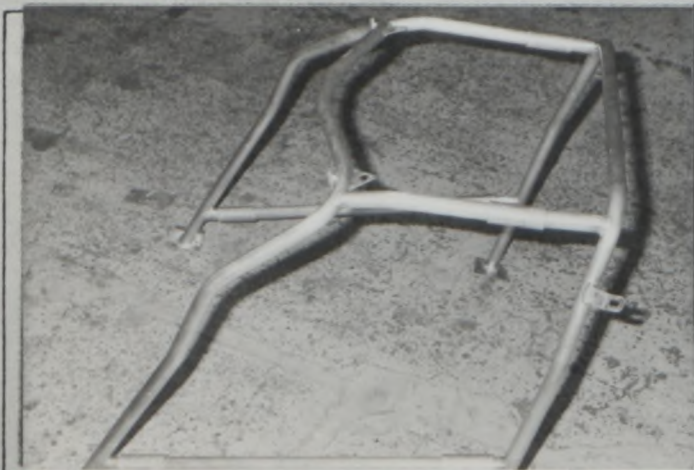

Nous attestons que le présent arceau / la présente cage de sécurité répond aux dispositions de l'Annexe J de la FIA, en particulier en ce qui concerne ses implantations, ses connexions et ses résistances aux contraintes.  
We certify that the present rollbar/rollcage complies with the conditions of the FIA Appendix J, in particular with regard to its attachments, its connections and its stress resistances.

Signature du représentant du constructeur du véhicule  
Signature of the car manufacturer representative

J. TODT



Marque PEUGEOT      Modèle 205 TURBO 16      N° Homol. B 262  
Make \_\_\_\_\_      Model \_\_\_\_\_

PHOTOS OU DESSINS DES FIXATIONS SUR LA COQUE :  
PHOTOS OR DRAWINGS OF THE ATTACHMENTS ON THE BODY :

N° Ext. 16-11V0

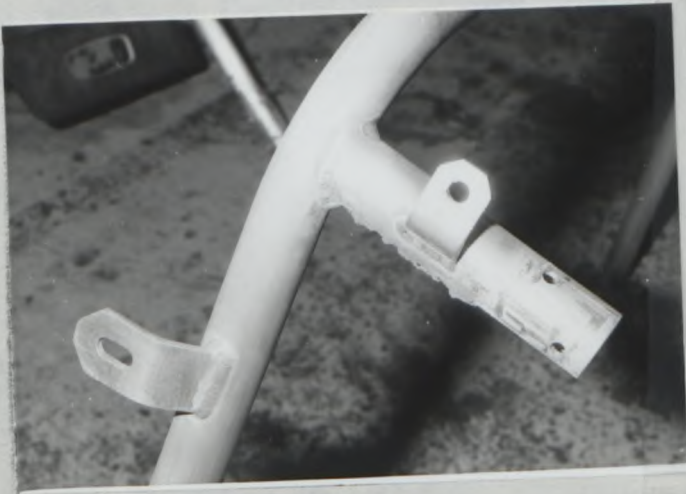
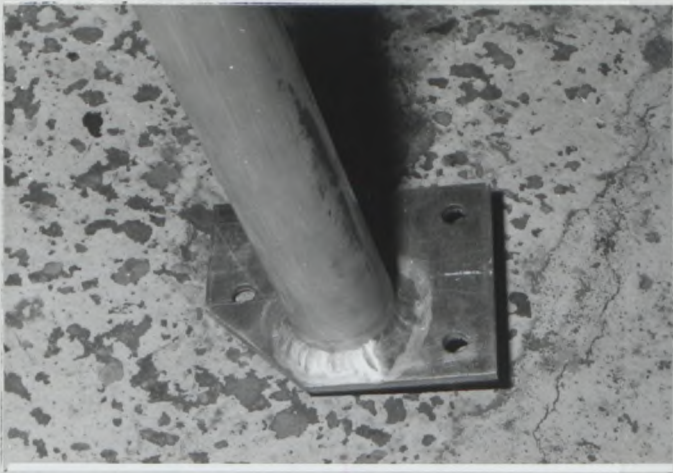



# FEDERATION INTERNATIONALE DU SPORT AUTOMOBILE

Homologation N°

B 262

Extension N°

17-12 VO

FICHE D'EXTENSION A L'HOMOLOGATION OFFICIELLE FISA  
FORM OF EXTENSION TO THE OFFICIAL FISA HOMOLOGATION

- ES Evolution sportive du type / Sporting evolution of the type
- ET Evolution normale du type / Normal evolution of the type
- VF Variante de fourniture / Supply variant
- VO Variante option / Option variant
- ER Errata / Erratum

Homologation valable dès le  
Homologation valid as from

- 1 JAN. 1986

en groupe B  
in group

Constructeur PEUGEOT  
Manufacturer

Modèle et type 205 TURBO 16  
Model and type

Page ou ext. Page or ext.	Art. Art.	Description Description	Photo 17-18-19	Photo 17-18-19																																		
		e) Nombre de cylindres par roue: Number of cylinders per wheel: e1) Alésage Bore f) Freins à tambours: Drum brakes: f1) Diamètre intérieur Interior diameter f2) Nombre de mâchoires par roue Number of shoes per wheel f3) Surface de freinage Braking surface f4) Largeur des garnitures Width of the shoes g) Freins à disques: Disc brakes: g1) Nombres de sabots par roue Number of pads per wheel g2) Nombre d'étriers par roue Number of calipers per wheel	<table border="1"> <thead> <tr> <th>Avant / Front</th> <th>Arrière / Rear</th> </tr> </thead> <tbody> <tr> <td>4 à 8</td> <td>4 à 8</td> </tr> <tr> <td>_____ mm</td> <td>_____ mm</td> </tr> <tr> <td>_____ mm (± 1.5 mm)</td> <td>_____ mm (± 1.5 mm)</td> </tr> <tr> <td>_____ cm<sup>2</sup></td> <td>_____ cm<sup>2</sup></td> </tr> <tr> <td>_____ mm</td> <td>_____ mm</td> </tr> <tr> <td>2 à 4</td> <td>2 à 4</td> </tr> <tr> <td>1 à 2</td> <td>1 à 2</td> </tr> </tbody> </table>	Avant / Front	Arrière / Rear	4 à 8	4 à 8	_____ mm	_____ mm	_____ mm (± 1.5 mm)	_____ mm (± 1.5 mm)	_____ cm <sup>2</sup>	_____ cm <sup>2</sup>	_____ mm	_____ mm	2 à 4	2 à 4	1 à 2	1 à 2	<table border="1"> <thead> <tr> <th>AV / Front</th> <th>AR / Rear</th> </tr> </thead> <tbody> <tr> <td>Alu + Magnesium</td> <td>Alu + Magnesium</td> </tr> <tr> <td>28,2 _____ mm</td> <td>28,2 _____ mm</td> </tr> <tr> <td>327,5 _____ mm (± 1 mm)</td> <td>327,5 _____ mm (± 1 mm)</td> </tr> <tr> <td>327,5 _____ mm</td> <td>327,5 _____ mm</td> </tr> <tr> <td>220 _____ mm</td> <td>220 _____ mm</td> </tr> <tr> <td>133 _____ mm</td> <td>133 _____ mm</td> </tr> <tr> <td>oui/non yes/no</td> <td>oui/non yes/no</td> </tr> <tr> <td>924,5 _____ cm<sup>2</sup></td> <td>924,5 _____ cm<sup>2</sup></td> </tr> </tbody> </table>	AV / Front	AR / Rear	Alu + Magnesium	Alu + Magnesium	28,2 _____ mm	28,2 _____ mm	327,5 _____ mm (± 1 mm)	327,5 _____ mm (± 1 mm)	327,5 _____ mm	327,5 _____ mm	220 _____ mm	220 _____ mm	133 _____ mm	133 _____ mm	oui/non yes/no	oui/non yes/no	924,5 _____ cm <sup>2</sup>	924,5 _____ cm <sup>2</sup>
Avant / Front	Arrière / Rear																																					
4 à 8	4 à 8																																					
_____ mm	_____ mm																																					
_____ mm (± 1.5 mm)	_____ mm (± 1.5 mm)																																					
_____ cm <sup>2</sup>	_____ cm <sup>2</sup>																																					
_____ mm	_____ mm																																					
2 à 4	2 à 4																																					
1 à 2	1 à 2																																					
AV / Front	AR / Rear																																					
Alu + Magnesium	Alu + Magnesium																																					
28,2 _____ mm	28,2 _____ mm																																					
327,5 _____ mm (± 1 mm)	327,5 _____ mm (± 1 mm)																																					
327,5 _____ mm	327,5 _____ mm																																					
220 _____ mm	220 _____ mm																																					
133 _____ mm	133 _____ mm																																					
oui/non yes/no	oui/non yes/no																																					
924,5 _____ cm <sup>2</sup>	924,5 _____ cm <sup>2</sup>																																					
		g3) Matériau des étriers Caliper material g4) Epaisseur maximale du disque Maximum disc thickness g5) Diamètre extérieur du disque Exterior diameter of the disc g6) Diamètre extérieur de frottement des sabots Exterior diameter of the shoe's rubbing surface g7) Diamètre intérieur de frottement des sabots Interior diameter of the shoe's rubbing surface g8) Longueur hors-tout des sabots Overall length of the shoes g9) Disques ventilés Ventilated disc g10) Surface de freinage par roue Braking surface per wheel																																				



*Signature*

Marque PEUGEOT Modèle 205 TURBO 16 N° Homol. B 262  
Make \_\_\_\_\_ Model \_\_\_\_\_

PHOTOS / PHOTOS

N° Ext. 17-12 VO

Photo 17

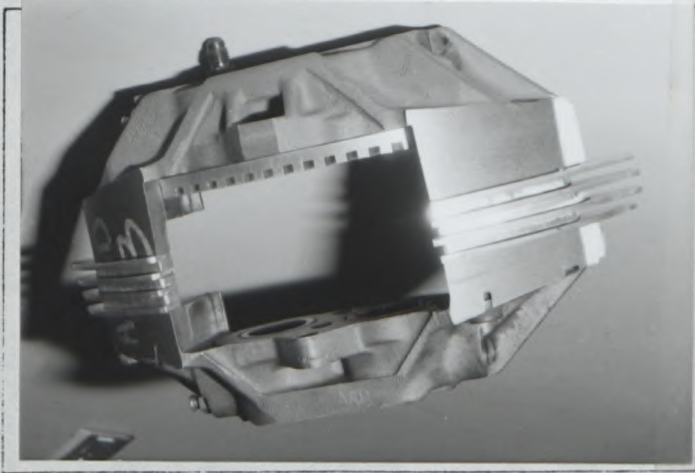
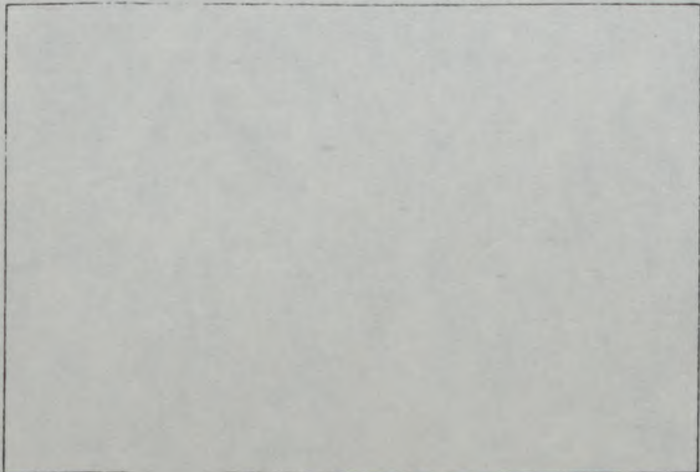
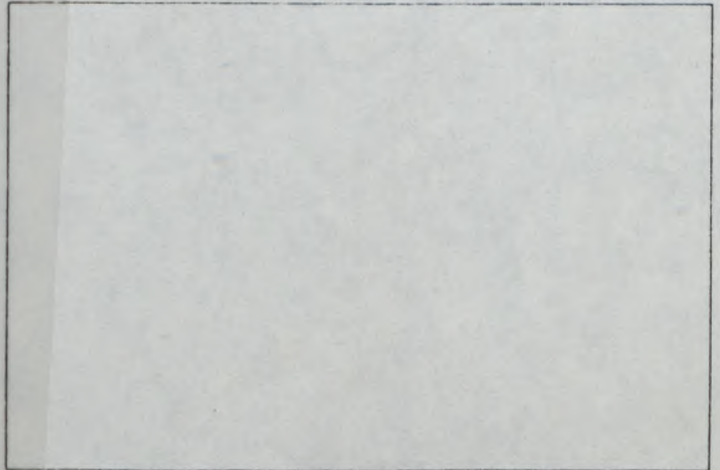
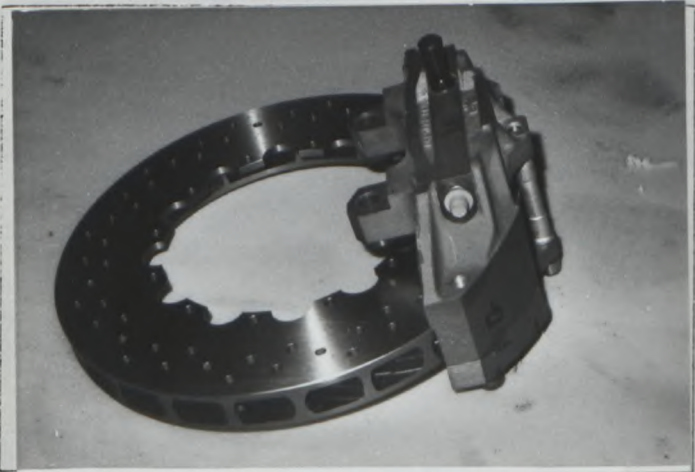

Photo 18



Photo 19





# FEDERATION INTERNATIONALE DU SPORT AUTOMOBILE

Homologation N°

B-262

Extension N°

18 - 13 VO

FICHE D'EXTENSION A L'HOMOLOGATION OFFICIELLE FISA  
FORM OF EXTENSION TO THE OFFICIAL FISA HOMOLOGATION

ET Evolution normale du type: dès le numéro de châssis  
Normal evolution of the type: as from chassis number \_\_\_\_\_

VF Variante de fourniture / Supply variant

VO Variante option / Option variant

ER Errata / Erratum

Homologation valable dès le \_\_\_\_\_ - 1 JAN. 1986 \_\_\_\_\_ en groupe B  
Homologation valid as from \_\_\_\_\_ in group \_\_\_\_\_

Constructeur PEUGEOT Modèle et type 205 TURBO 16  
Manufacturer \_\_\_\_\_ Model and type \_\_\_\_\_

Page ou ext. Page or ext.	Art. Art.	Description Description	Photo 1-2-3	
			Avant / Front	Arrière / Rear
	803	e) Nombre de cylindres par roue: Number of cylinders per wheel:	4	4
		e1) Alésage Bore	41.2 mm	41.2 mm
		f) Freins à tambours Drum brakes:		
		f1) Diamètre intérieur Interior diameter	mm (± 1,5 mm)	mm (± 1,5 mm)
		f2) Nombre de mâchoires par roue: Number of shoes per wheel		
		f3) Surface de freinage Braking surface	cm <sup>2</sup>	cm <sup>2</sup>
		f4) Largeur des garnitures Width of the shoes	mm	mm
		g) Freins à disques Disc brakes:		
		g1) Nombre de sabots par roue Number of pads per wheel	2	2
		g2) Nombre d'étriers par roue Number of calipers per wheel	1	1
		g3) Matériau des étriers Caliper material	ALU	ALU
		g4) Epaisseur maximale du disque Maximum disc thickness	28 mm	28 mm
		g5) Diamètre extérieur du disque Exterior diameter of the disc	298 mm (± 1 mm)	298 mm (± 1 mm)
		g6) Diamètre extérieur de frottement des sabots Exterior diameter of the shoe's rubbing surface	298 mm	298 mm
		g7) Diamètre intérieur de frottement des sabots Interior diameter of the shoe's rubbing surface	209 mm	209 mm
		g8) Longueur hors-tout des sabots Overall length of the shoes	126.5 mm	126.5 mm
		g9) Disques ventilés Ventilated disc	oui/non yes/no	oui/non yes/no
		g10) Surface de freinage par roue: Braking surface per wheel:	709 cm <sup>2</sup>	709 cm <sup>2</sup>



*Signature*

Marque PEUGEOT Modèle 205 TURBO 16 N° Homol. B-262  
Make \_\_\_\_\_ Model \_\_\_\_\_ N° Ext. \_\_\_\_\_

**18 - 13 V0**

N° Ext. \_\_\_\_\_

Page ou ext. Page or ext.	Art. Art.	Description Description	
	803	Frein Etrier (comme photo 1) avec frein à main.	Photo 4.
	803	Frein Tôle de protection.	Photo 5.





Marque PEUGEOT Modèle 205 TURBO 16 N° Homol. B-262  
Make \_\_\_\_\_ Model \_\_\_\_\_ N° Ext. \_\_\_\_\_

**18 - 13 V0**

PHOTOS / PHOTOS

N° Ext. \_\_\_\_\_

1.

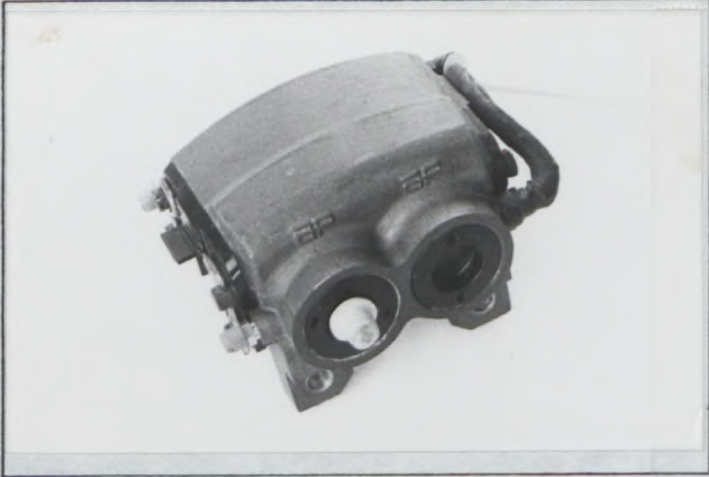

2.

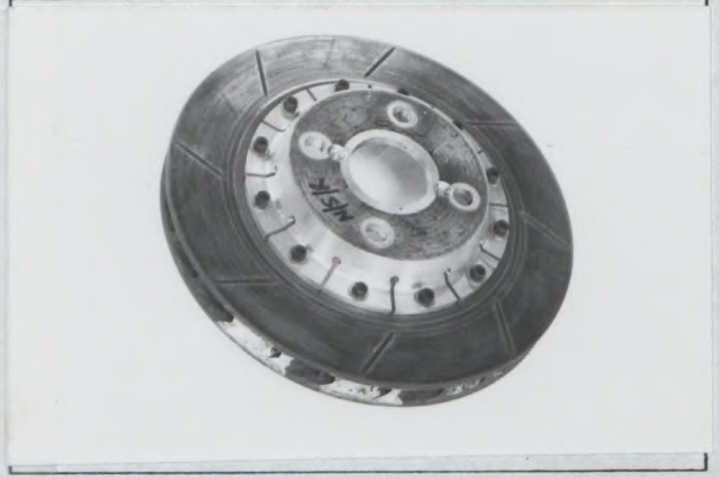

3.

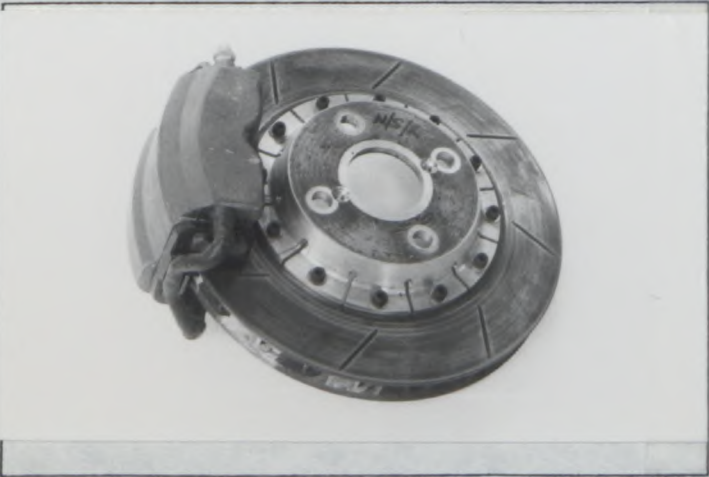

4.



5.





# FEDERATION INTERNATIONALE DU SPORT AUTOMOBILE

Homologation N°

B 262

Extension N°

19 - 14 VO

FICHE D'EXTENSION A L'HOMOLOGATION OFFICIELLE FISA  
FORM OF EXTENSION TO THE OFFICIAL FISA HOMOLOGATION

- ES Evolution sportive du type / Sporting evolution of the type
- ET Evolution normale du type / Normal evolution of the type
- VF Variantè de fourniture / Supply variant
- VO Variante option / Option variant
- ER Errata / Erratum

Homologation valable dès le - 1 FEV. 1986 en groupe B  
Homologation valid as from \_\_\_\_\_ in group \_\_\_\_\_

Constructeur PEUGEOT Modèle et type 205 TURBO 16  
Manufacturer \_\_\_\_\_ Model and type \_\_\_\_\_

Page ou ext. Page or ext.	Art. Art.	Description Description	
		- Bras de suspension supérieur AV renforcé	Photo 1
			Photo 2
		- Fixations supérieures d'amortisseurs AV	Photo 3
			Photo 4
			Photo 5
		- Refroidissement AV. et AR. par eau pompe électrique (pour Freins - Capacité 5 litres)	Photo 10
		- Toutes glaces teintées	
		- Colonne de direction renforcée	Photo 11
		- Bras de suspension renforcé INF. AV.	photo 12
		- Bras de suspension renforcé SUP. AR.	Photo 13
		- Bras de suspension renforcé INF. AR.	Photo 14
		- Bielle de crémaillère renforcée	Photo 15
		- Bielle de suspension AR. renforcée	Photo 16



Marque PEUGEOT  
Make

Modèle 205 TURBO 16  
Model

N° Homol. B 262

PHOTOS / PHOTOS

N° Ext. 19 - 14 V0

Photo 1



Photo 2



Photo 3



Photo 4

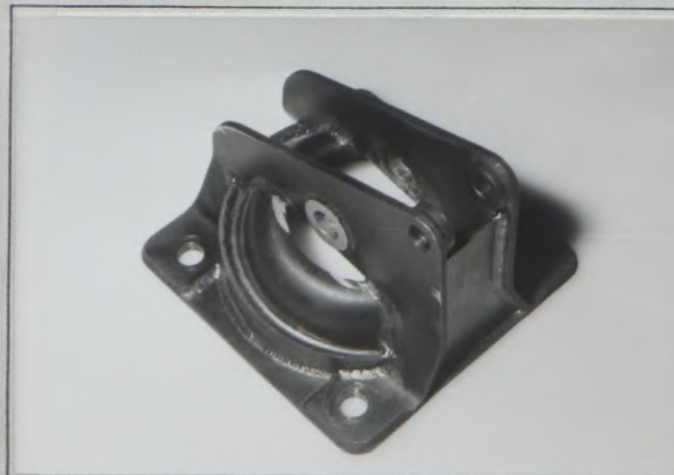
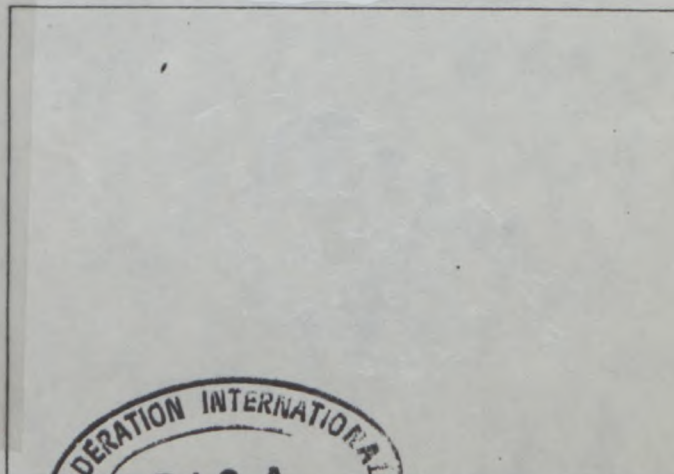

Photo 5



FÉDÉRATION INTERNATIONALE  
F.I.S.A.  
DE L'AUTOMOBILE

Marque Make PEUGEOT

Modèle Model 205 TURBO 16

N° Homol. B 262

PHOTOS / PHOTOS

N° Ext. 19 - 14 VO

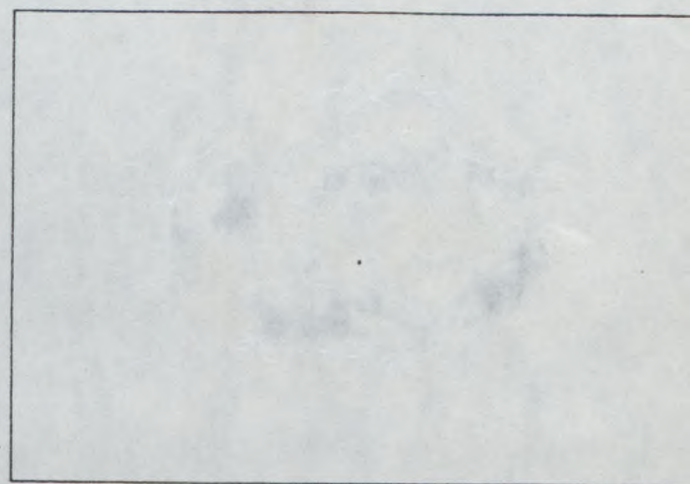
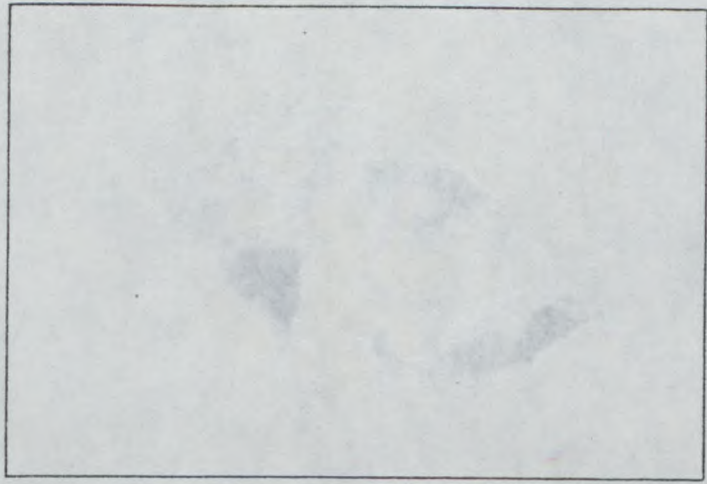

Photo 10

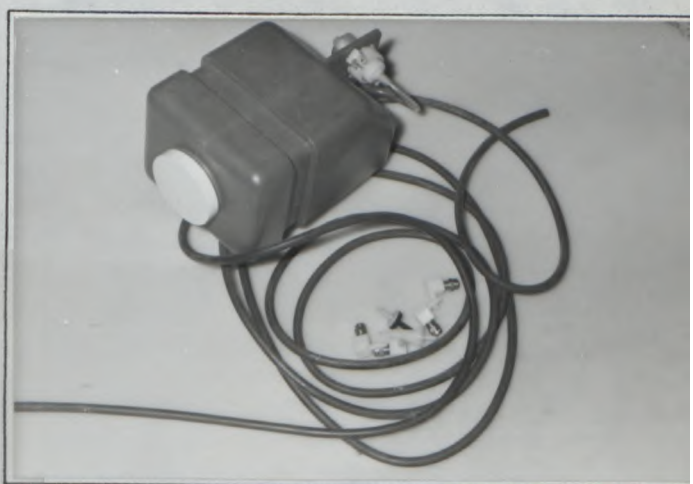
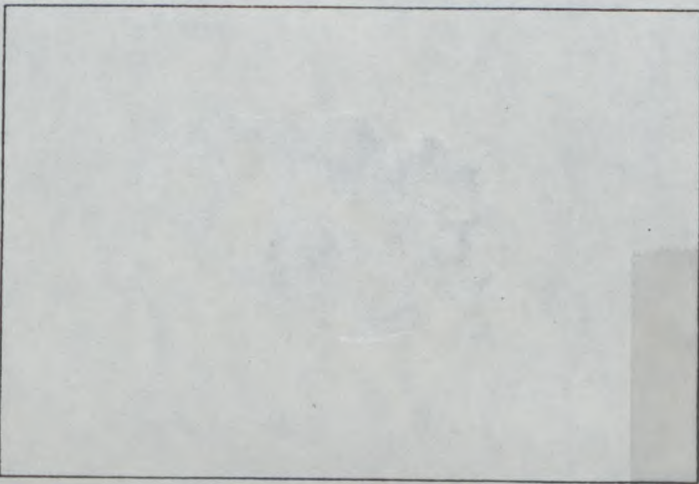
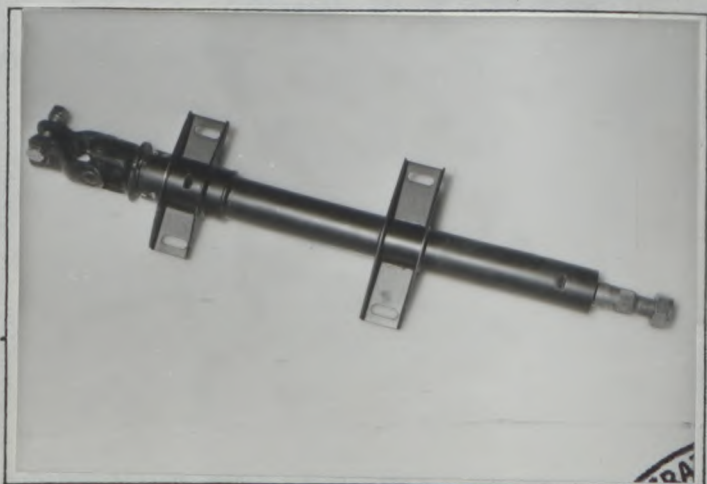

Photo 11

Photo 12



FEDERATION INTERNATIONALE F.I.S.A. DE L'AUTOMOBILE

Marque PEUGEOT      Modèle 205 TURBO 16      N° Homol B 262  
Make \_\_\_\_\_      Model \_\_\_\_\_

PHOTOS / PHOTOS

N° Ext. 19 - 14 VO

Photo 13



Photo 14

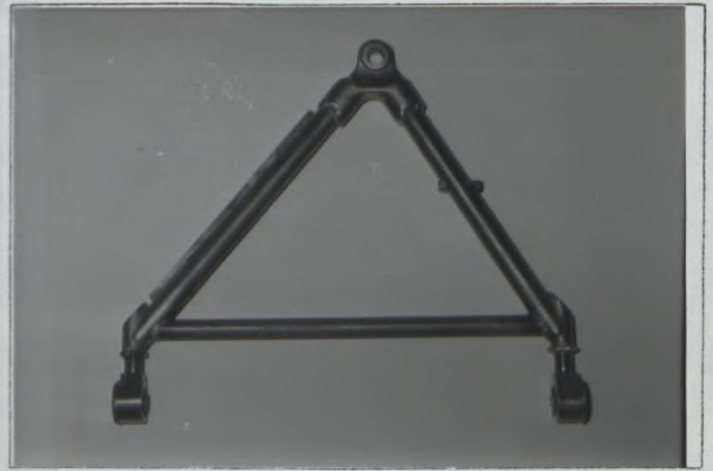

Photo 15



Photo 16





# FEDERATION INTERNATIONALE DU SPORT AUTOMOBILE

Homologation N°

B 262

Extension N°

20-04 ER

FICHE D'EXTENSION A L'HOMOLOGATION OFFICIELLE FISA  
FORM OF EXTENSION TO THE OFFICIAL FISA HOMOLOGATION

- ES Evolution sportive du type / Sporting evolution of the type
- ET Evolution normale du type / Normal evolution of the type
- VF Variante de fourniture / Supply variant
- VO Variante option / Option variant
- ER Errata / Erratum

Homologation valable dès le - 1 AVR. 1986 en groupe B  
Homologation valid as from \_\_\_\_\_ in group \_\_\_\_\_

Constructeur PEUGEOT Modèle et type 205 TURBO 16  
Manufacturer \_\_\_\_\_ Model and type \_\_\_\_\_

Page ou ext. Page or ext.	Art. Art.	Description Description
------------------------------	--------------	----------------------------

09-02 ET

603

e) Rapports  
Ratios

BV. ANNULEE

	Manuelle / Manual			Automatique / Automatic			E.V. suppl. / Additional G.B.		
	rappports ratio	nombre de dents/ number of teeth	synchro.	rappports ratio	nombre de dents/ number of teeth	synchro.	rappports ratio	nombre de dents/ number of teeth	synchro.
1	2,533	38/15	X				2,533	38/15	X
2	1,789	34/19	X				1,789	34,19	X
3	1,357	38/28	X				1,357	38/28	X
4	1,129	35/31	X				1,129	35/31	X
5	0,961	25/26	X				0,961	25/26	X
6							0,806	25/31	X
AR/R Constante Constant.	2,695	41/22/13					2,695	41/22/13	

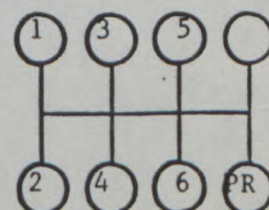
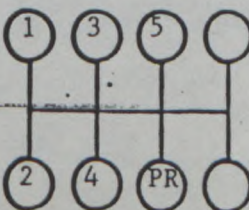
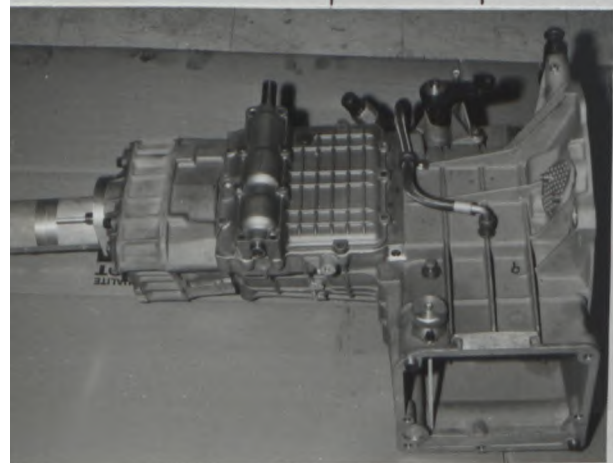

*Signature*



# FEDERATION INTERNATIONALE DU SPORT AUTOMOBILE

Homologation N°

B 262

Extension N°

21-15 VO

FICHE D'EXTENSION A L'HOMOLOGATION OFFICIELLE FISA  
FORM OF EXTENSION TO THE OFFICIAL FISA HOMOLOGATION

- ES** Evolution sportive du type / Sporting evolution of the type
- ET** Evolution normale du type / Normal evolution of the type
- VF** Variante de fourniture / Supply variant
- VO** Variante option / Option variant
- ER** Errata / Erratum

Homologation valable dès le \_\_\_\_\_ en groupe B  
Homologation valid as from - 1 AVR. 1986 in group \_\_\_\_\_

Constructeur PEUGEOT Modèle et type 205 TURBO 16  
Manufacturer \_\_\_\_\_ Model and type \_\_\_\_\_

Page ou ext. Page or ext.	Art. Art.	Description Description	Bi-disques																																			
			Photo 1	Photo 1																																		
	803	e) Nombre de cylindres par roue: Number of cylinders per wheel: e1) Alésage Bore f) Freins à tambours: Drum brakes: f1) Diamètre intérieur Interior diameter f2) Nombre de mâchoires par roue Number of shoes per wheel f3) Surface de freinage Braking surface f4) Largeur des garnitures Width of the shoes g) Freins à disques: Disc brakes: g1) Nombres de sabots par roue Number of pads per wheel g2) Nombre d'étriers par roue Number of calipers per wheel g3) Matériau des étriers Caliper material g4) Epaisseur maximale du disque Maximum disc thickness g5) Diamètre extérieur du disque Exterior diameter of the disc g6) Diamètre extérieur de frottement des sabots Exterior diameter of the shoe's rubbing surface g7) Diamètre intérieur de frottement des sabots Interior diameter of the shoe's rubbing surface g8) Longueur hors-tout des sabots Overall length of the shoes g9) Disques ventilés Ventilated disc g10) Surface de freinage par roue Braking surface per wheel	<table border="1"> <thead> <tr> <th>Avant / Front</th> <th>Arrière / Rear</th> </tr> </thead> <tbody> <tr> <td>1</td> <td>1</td> </tr> <tr> <td>44,45 mm</td> <td>44,45 mm</td> </tr> <tr> <td>mm (± 1.5 mm)</td> <td>mm (± 1.5 mm)</td> </tr> <tr> <td>cm<sup>2</sup></td> <td>cm<sup>2</sup></td> </tr> <tr> <td>mm</td> <td>mm</td> </tr> <tr> <td>4</td> <td>4</td> </tr> <tr> <td>1</td> <td>1</td> </tr> </tbody> </table>	Avant / Front	Arrière / Rear	1	1	44,45 mm	44,45 mm	mm (± 1.5 mm)	mm (± 1.5 mm)	cm <sup>2</sup>	cm <sup>2</sup>	mm	mm	4	4	1	1	<table border="1"> <thead> <tr> <th>AV / Front</th> <th>AR / Rear</th> </tr> </thead> <tbody> <tr> <td>Aluminium</td> <td>Aluminium</td> </tr> <tr> <td>10,10 mm</td> <td>10,10 mm</td> </tr> <tr> <td>324 mm (± 1 mm)</td> <td>324 mm (± 1 mm)</td> </tr> <tr> <td>324 mm</td> <td>324 mm</td> </tr> <tr> <td>234 mm</td> <td>234 mm</td> </tr> <tr> <td>133,33 mm</td> <td>133,33 mm</td> </tr> <tr> <td>oui/non yes/no</td> <td>oui/non yes/no</td> </tr> <tr> <td>1577,72 cm<sup>2</sup></td> <td>1577,72 cm<sup>2</sup></td> </tr> </tbody> </table>	AV / Front	AR / Rear	Aluminium	Aluminium	10,10 mm	10,10 mm	324 mm (± 1 mm)	324 mm (± 1 mm)	324 mm	324 mm	234 mm	234 mm	133,33 mm	133,33 mm	oui/non yes/no	oui/non yes/no	1577,72 cm <sup>2</sup>	1577,72 cm <sup>2</sup>
Avant / Front	Arrière / Rear																																					
1	1																																					
44,45 mm	44,45 mm																																					
mm (± 1.5 mm)	mm (± 1.5 mm)																																					
cm <sup>2</sup>	cm <sup>2</sup>																																					
mm	mm																																					
4	4																																					
1	1																																					
AV / Front	AR / Rear																																					
Aluminium	Aluminium																																					
10,10 mm	10,10 mm																																					
324 mm (± 1 mm)	324 mm (± 1 mm)																																					
324 mm	324 mm																																					
234 mm	234 mm																																					
133,33 mm	133,33 mm																																					
oui/non yes/no	oui/non yes/no																																					
1577,72 cm <sup>2</sup>	1577,72 cm <sup>2</sup>																																					



*Signature*



# FEDERATION INTERNATIONALE DU SPORT AUTOMOBILE

Homologation N°

B 262

Extension N°

21 - 15 VO

FICHE D'EXTENSION A L'HOMOLOGATION OFFICIELLE FISA  
FORM OF EXTENSION TO THE OFFICIAL FISA HOMOLOGATION

- ES Evolution sportive du type / Sporting evolution of the type
- ET Evolution normale du type / Normal evolution of the type
- VF Variante de fourniture / Supply variant
- VO Variante option / Option variant
- ER Errata / Erratum

Homologation valable dès le - 1 AVR. 1986 en groupe B  
Homologation valid as from \_\_\_\_\_ in group \_\_\_\_\_

Constructeur PEUGEOT Modèle et type 205 TURBO 16  
Manufacturer \_\_\_\_\_ Model and type \_\_\_\_\_

Page ou ext. Page or ext.	Art. Art.	Description Description	Bi-disques	
			Photo 1	Photo 1
	803	e) Nombre de cylindres par roue: Number of cylinders per wheel: e1) Alésage Bore f) Freins à tambours: Drum brakes: f1) Diamètre intérieur Interior diameter f2) Nombre de mâchoires par roue. Number of shoes per wheel f3) Surface de freinage Braking surface f4) Largeur des garnitures Width of the shoes g) Freins à disques: Disc brakes: g1) Nombre de sabots par roue Number of pads per wheel g2) Nombre d'étriers par roue Number of calipers per wheel  g3) Matériau des étriers Caliper material g4) Epaisseur maximale du disque Maximum disc thickness g5) Diamètre extérieur du disque Exterior diameter of the disc g6) Diamètre extérieur de frottement des sabots Exterior diameter of the shoe's rubbing surface g7) Diamètre intérieur de frottement des sabots Interior diameter of the shoe's rubbing surface g8) Longueur hors-tout des sabots Overall length of the shoes g9) Disques ventilés Ventilated disc g10) Surface de freinage par roue Braking surface per wheel	Avant / Front <u>1</u> <u>44,45</u> mm _____ mm (± 1.5 mm) _____ _____ cm' _____ mm 4 1 Aluminium <u>10,10</u> mm <u>322,15</u> mm (± 1 mm) <u>322</u> mm <u>234</u> mm <u>133,33</u> mm oui/non yes/no <u>1537,12</u> cm'	Arrière / Rear <u>1</u> <u>44,45</u> mm _____ mm (± 1.5 mm) _____ _____ cm' _____ mm 4 1 Aluminium <u>10,10</u> mm <u>322,15</u> mm (± 1 mm) <u>322</u> mm <u>234</u> mm <u>133,33</u> mm oui/non yes/no <u>1537,12</u> cm'







# FEDERATION INTERNATIONALE DU SPORT AUTOMOBILE

Homologation N°

B 262

Extension N°

21 - 15 VO

FICHE D'EXTENSION A L'HOMOLOGATION OFFICIELLE FISA  
FORM OF EXTENSION TO THE OFFICIAL FISA HOMOLOGATION

- ES Evolution sportive du type / Sporting evolution of the type
- ET Evolution normale du type / Normal evolution of the type
- VF Variante de fourniture / Supply variant
- VO Variante option / Option variant
- ER Errata / Erratum

Homologation valable dès le - 1 AVR. 1986 en groupe B  
Homologation valid as from \_\_\_\_\_ in group \_\_\_\_\_

Constructeur PEUGEOT Modèle et type 205 TURBO 16  
Manufacturer \_\_\_\_\_ Model and type \_\_\_\_\_

Page ou ext. Page or ext.	Art. Art.	Description Description	Bi-disques																																			
			Photo 1	Photo 1																																		
	803	e) Nombre de cylindres par roue: Number of cylinders per wheel: e1) Alésage Bore f) Freins à tambours: Drum brakes: f1) Diamètre intérieur Interior diameter f2) Nombre de mâchoires par roue. Number of shoes per wheel f3) Surface de freinage Braking surface f4) Largeur des garnitures Width of the shoes g) Freins à disques: Disc brakes: g1) Nombres de sabots par roue Number of pads per wheel g2) Nombre d'étriers par roue Number of calipers per wheel  g3) Matériau des étriers Caliper material g4) Epaisseur maximale du disque Maximum disc thickness g5) Diamètre extérieur du disque Exterior diameter of the disc g6) Diamètre extérieur de frottement des sabots Exterior diameter of the shoe's rubbing surface g7) Diamètre intérieur de frottement des sabots Interior diameter of the shoe's rubbing surface g8) Longueur hors-tout des sabots Overall length of the shoes g9) Disques ventilés Ventilated disc g10) Surface de freinage par roue Braking surface per wheel	<table border="1"> <thead> <tr> <th>Avant / Front</th> <th>Arrière / Rear</th> </tr> </thead> <tbody> <tr> <td>1</td> <td>1</td> </tr> <tr> <td>44,45 mm</td> <td>44,45 mm</td> </tr> <tr> <td>_____ mm (± 1,5 mm)</td> <td>_____ mm (± 1,5 mm)</td> </tr> <tr> <td>_____ cm<sup>2</sup></td> <td>_____ cm<sup>2</sup></td> </tr> <tr> <td>_____ mm</td> <td>_____ mm</td> </tr> <tr> <td>4</td> <td>4</td> </tr> <tr> <td>1</td> <td>1</td> </tr> </tbody> </table>	Avant / Front	Arrière / Rear	1	1	44,45 mm	44,45 mm	_____ mm (± 1,5 mm)	_____ mm (± 1,5 mm)	_____ cm <sup>2</sup>	_____ cm <sup>2</sup>	_____ mm	_____ mm	4	4	1	1	<table border="1"> <thead> <tr> <th>AV / Front</th> <th>AR / Rear</th> </tr> </thead> <tbody> <tr> <td>Aluminium</td> <td>Aluminium</td> </tr> <tr> <td>10,10 mm</td> <td>10,10 mm</td> </tr> <tr> <td>320 mm (± 1 mm)</td> <td>320 mm (± 1 mm)</td> </tr> <tr> <td>320 mm</td> <td>320 mm</td> </tr> <tr> <td>234 mm</td> <td>234 mm</td> </tr> <tr> <td>133,33 mm</td> <td>133,33 mm</td> </tr> <tr> <td>oui/yes oui/yes</td> <td>oui/yes oui/yes</td> </tr> <tr> <td>1496,76 cm<sup>2</sup></td> <td>1496,76 cm<sup>2</sup></td> </tr> </tbody> </table>	AV / Front	AR / Rear	Aluminium	Aluminium	10,10 mm	10,10 mm	320 mm (± 1 mm)	320 mm (± 1 mm)	320 mm	320 mm	234 mm	234 mm	133,33 mm	133,33 mm	oui/yes oui/yes	oui/yes oui/yes	1496,76 cm <sup>2</sup>	1496,76 cm <sup>2</sup>
Avant / Front	Arrière / Rear																																					
1	1																																					
44,45 mm	44,45 mm																																					
_____ mm (± 1,5 mm)	_____ mm (± 1,5 mm)																																					
_____ cm <sup>2</sup>	_____ cm <sup>2</sup>																																					
_____ mm	_____ mm																																					
4	4																																					
1	1																																					
AV / Front	AR / Rear																																					
Aluminium	Aluminium																																					
10,10 mm	10,10 mm																																					
320 mm (± 1 mm)	320 mm (± 1 mm)																																					
320 mm	320 mm																																					
234 mm	234 mm																																					
133,33 mm	133,33 mm																																					
oui/yes oui/yes	oui/yes oui/yes																																					
1496,76 cm <sup>2</sup>	1496,76 cm <sup>2</sup>																																					





# FEDERATION INTERNATIONALE DU SPORT AUTOMOBILE

Homologation N°

B 262

Extension N°

21-15 VO

FICHE D'EXTENSION A L'HOMOLOGATION OFFICIELLE FISA  
FORM OF EXTENSION TO THE OFFICIAL FISA HOMOLOGATION

- ES** Evolution sportive du type / Sporting evolution of the type
- ET** Evolution normale du type / Normal evolution of the type
- VF** Variante de fourniture / Supply variant
- VO** Variante option / Option variant
- ER** Errata / Erratum

Homologation valable dès le  
Homologation valid as from

- 1 AVR. 1986

en groupe  
in group B

Constructeur  
Manufacturer PEUGEOT

Modèle et type  
Model and type 205 TURBO 16

Page ou ext. Page or ext.	Art. Art.	Description Description	Bi-disques	
			Photo 1	Photo 1
	803	e) Nombre de cylindres par roue: Number of cylinders per wheel: e1) Alésage Bore f) Freins à tambours: Drum brakes: f1) Diamètre intérieur Interior diameter f2) Nombre de mâchoires par roue. Number of shoes per wheel f3) Surface de freinage Braking surface f4) Largeur des garnitures Width of the shoes g) Freins à disques: Disc brakes: g1) Nombres de sabots par roue Number of pads per wheel g2) Nombre d'étriers par roue Number of calipers per wheel g3) Matériau des étriers Caliper material g4) Epaisseur maximale du disque Maximum disc thickness g5) Diamètre extérieur du disque Exterior diameter of the disc g6) Diamètre extérieur de frottement des sabots Exterior diameter of the shoe's rubbing surface g7) Diamètre intérieur de frottement des sabots Interior diameter of the shoe's rubbing surface g8) Longueur hors-tout des sabots Overall length of the shoes g9) Disques ventilés Ventilated disc g10) Surface de freinage par roue Braking surface per wheel	Avant / Front 1 44,45 mm   mm (± 1.5 mm)  cm' mm 4 1  Aluminium 10,10 mm 318 mm (± 1 mm) 318 mm 234 mm 133,33 mm oui/XXX yes/XXX 1456,68 cm'	Arrière / Rear 1 44,45 mm   mm (± 1.5 mm)  cm' mm 4 1  Aluminium 10,10 mm 318 mm (± 1 mm) 318 mm 234 mm 133,33 mm oui/XXX yes/XXX 1456,68 cm'





# FEDERATION INTERNATIONALE DU SPORT AUTOMOBILE

Homologation N°

B 262

Extension N°

21-15 V

FICHE D'EXTENSION A L'HOMOLOGATION OFFICIELLE FISA  
FORM OF EXTENSION TO THE OFFICIAL FISA HOMOLOGATION

- ES** Evolution sportive du type / Sporting evolution of the type
- ET** Evolution normale du type / Normal evolution of the type
- VF** Variante de fourniture / Supply variant
- VO** Variante option / Option variant
- ER** Errata / Erratum

Homologation valable dès le -1 AVR. 1986 en groupe B  
Homologation valid as from \_\_\_\_\_ in group \_\_\_\_\_

Constructeur PEUGEOT Modèle et type 205 TURBO 16  
Manufacturer \_\_\_\_\_ Model and type \_\_\_\_\_

Page ou ext. Page or ext.	Art. Art.	Description Description	Photo 2-3	Photo 2-3																																		
	803	e) Nombre de cylindres par roue: Number of cylinders per wheel: e1) Alésage Bore f) Freins à tambours: Drum brakes: f1) Diamètre intérieur Interior diameter f2) Nombre de mâchoires par roue. Number of shoes per wheel f3) Surface de freinage Braking surface f4) Largeur des garnitures Width of the shoes g) Freins à disques: Disc brakes: g1) Nombre de sabots par roue Number of pads per wheel g2) Nombre d'étriers par roue Number of calipers per wheel  g3) Matériau des étriers Caliper material g4) Epaisseur maximale du disque Maximum disc thickness g5) Diamètre extérieur du disque Exterior diameter of the disc g6) Diamètre extérieur de frottement des sabots Exterior diameter of the shoe's rubbing surface g7) Diamètre intérieur de frottement des sabots Interior diameter of the shoe's rubbing surface g8) Longueur hors-tout des sabots Overall length of the shoes g9) Disques ventilés Ventilated disc g10) Surface de freinage par roue Braking surface per wheel	<table border="1"> <thead> <tr> <th>Avant / Front</th> <th>Arrière / Rear</th> </tr> </thead> <tbody> <tr> <td>4</td> <td>4</td> </tr> <tr> <td>42 et 38 mm</td> <td>42 et 38 mm</td> </tr> <tr> <td>_____ mm (± 1.5 mm)</td> <td>_____ mm (± 1.5 mm)</td> </tr> <tr> <td>_____ cm<sup>2</sup></td> <td>_____ cm<sup>2</sup></td> </tr> <tr> <td>_____ mm</td> <td>_____ mm</td> </tr> <tr> <td>2</td> <td>2</td> </tr> <tr> <td>1</td> <td>1</td> </tr> </tbody> </table>	Avant / Front	Arrière / Rear	4	4	42 et 38 mm	42 et 38 mm	_____ mm (± 1.5 mm)	_____ mm (± 1.5 mm)	_____ cm <sup>2</sup>	_____ cm <sup>2</sup>	_____ mm	_____ mm	2	2	1	1	<table border="1"> <thead> <tr> <th>AV / Front</th> <th>AR / Rear</th> </tr> </thead> <tbody> <tr> <td>Aluminium</td> <td>Aluminium</td> </tr> <tr> <td>28,1 mm</td> <td>28,1 mm</td> </tr> <tr> <td>315 mm (± 1 mm)</td> <td>315 mm (± 1 mm)</td> </tr> <tr> <td>315 mm</td> <td>315 mm</td> </tr> <tr> <td>220 mm</td> <td>220 mm</td> </tr> <tr> <td>133 mm</td> <td>133 mm</td> </tr> <tr> <td>oui/yes</td> <td>oui/yes</td> </tr> <tr> <td>798,36 cm<sup>2</sup></td> <td>798,36 cm<sup>2</sup></td> </tr> </tbody> </table>	AV / Front	AR / Rear	Aluminium	Aluminium	28,1 mm	28,1 mm	315 mm (± 1 mm)	315 mm (± 1 mm)	315 mm	315 mm	220 mm	220 mm	133 mm	133 mm	oui/yes	oui/yes	798,36 cm <sup>2</sup>	798,36 cm <sup>2</sup>
Avant / Front	Arrière / Rear																																					
4	4																																					
42 et 38 mm	42 et 38 mm																																					
_____ mm (± 1.5 mm)	_____ mm (± 1.5 mm)																																					
_____ cm <sup>2</sup>	_____ cm <sup>2</sup>																																					
_____ mm	_____ mm																																					
2	2																																					
1	1																																					
AV / Front	AR / Rear																																					
Aluminium	Aluminium																																					
28,1 mm	28,1 mm																																					
315 mm (± 1 mm)	315 mm (± 1 mm)																																					
315 mm	315 mm																																					
220 mm	220 mm																																					
133 mm	133 mm																																					
oui/yes	oui/yes																																					
798,36 cm <sup>2</sup>	798,36 cm <sup>2</sup>																																					





# FEDERATION INTERNATIONALE DU SPORT AUTOMOBILE

Homologation N°

B 262

Extension N°

21 - 15 VO

FICHE D'EXTENSION A L'HOMOLOGATION OFFICIELLE FISA  
FORM OF EXTENSION TO THE OFFICIAL FISA HOMOLOGATION

- ES** Evolution sportive du type / Sporting evolution of the type
- ET** Evolution normale du type / Normal evolution of the type
- VF** Variante de fourniture / Supply variant
- VO** Variante option / Option variant
- ER** Errata / Erratum

Homologation valable dès le \_\_\_\_\_ - 1 AVR. 1966 \_\_\_\_\_ en groupe B  
Homologation valid as from \_\_\_\_\_ in group \_\_\_\_\_

Constructeur PEUGEOT Modèle et type 205 TURBO 16  
Manufacturer \_\_\_\_\_ Model and type \_\_\_\_\_

Page ou ext. Page or ext.	Art. Art.	Description Description
	605	- Différentiel central • Rapport : 1,526 • Nombre de dents : 29/19



Marque PEUGEOT  
Make

Modèle 205 TURBO 16  
Model

N° Homol B 262

PHOTOS / PHOTOS

N° Ext. 21-15 V0

Photo 1

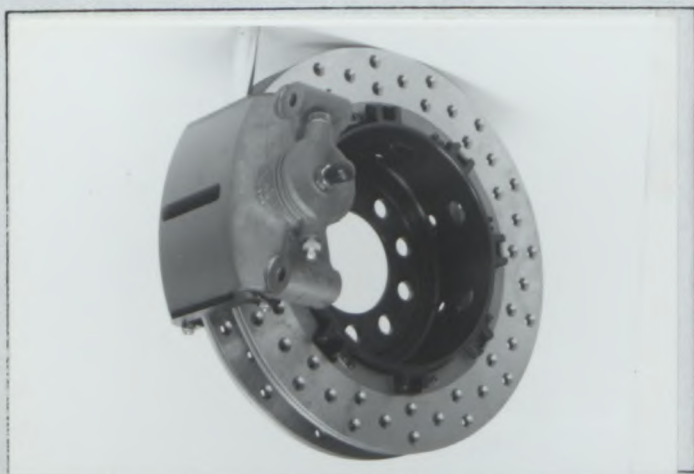

Photo 2

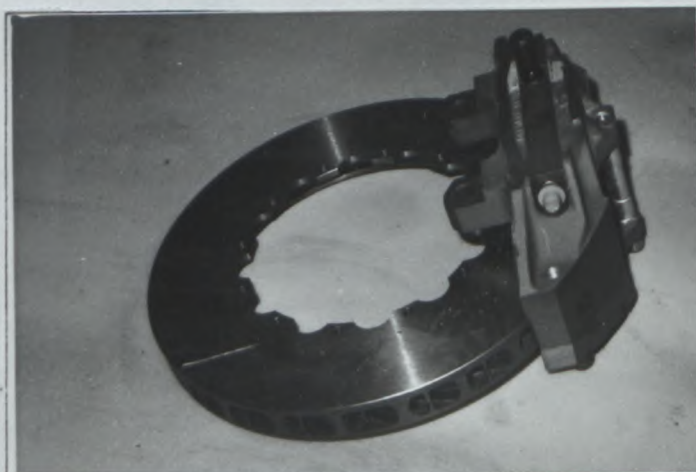
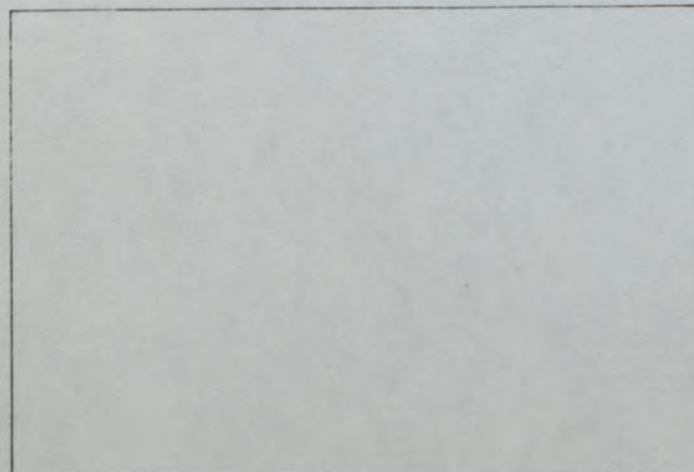
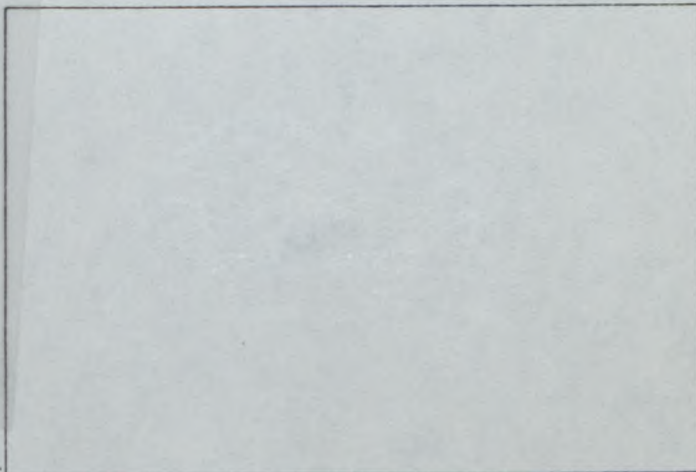
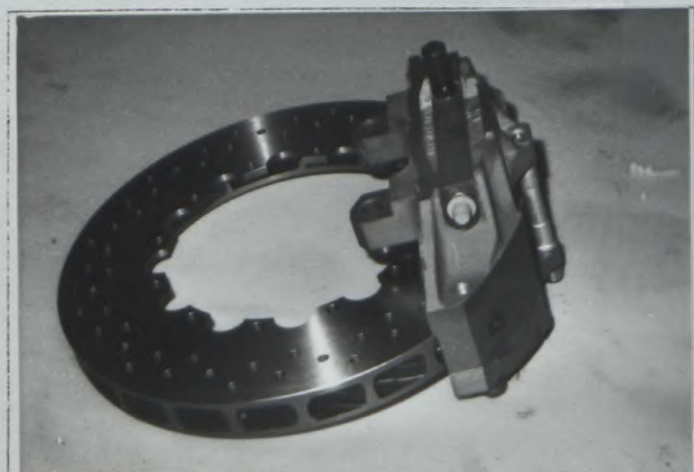

Photo 3





# FEDERATION INTERNATIONALE DU SPORT AUTOMOBILE

Homologation N°

B 262

Extension N°

**22 - 05 ER**

FICHE D'EXTENSION A L'HOMOLOGATION OFFICIELLE FISA  
FORM OF EXTENSION TO THE OFFICIAL FISA HOMOLOGATION

- ES Evolution sportive du type / Sporting evolution of the type
- ET Evolution normale du type / Normal evolution of the type
- VF Variante de fourniture / Supply variant
- VO Variante option / Option variant
- ER Errata / Erratum

Homologation valable dès le - 1 MAI 1986 en groupe B  
Homologation valid as from \_\_\_\_\_ in group \_\_\_\_\_

Constructeur PEUGEOT Modèle et type 205 TURBO 16  
Manufacturer \_\_\_\_\_ Model and type \_\_\_\_\_

Page ou ext. Page or ext.	Art. Art.	Description Description	Frein outbord et/ou inbord accolés aux ponts AV et AR																																			
05-03-VO	803	e) Nombre de cylindres par roue: Number of cylinders per wheel: e1) Alésage Bore f) Freins à tambours: Drum brakes: (1) Diamètre intérieur Interior diameter (2) Nombre de mâchoires par roue. Number of shoes per wheel (3) Surface de freinage Braking surface (4) Largeur des garnitures Width of the shoes g) Freins à disques: Disc brakes: g1) Nombre de sabots par roue Number of pads per wheel g2) Nombre d'étriers par roue Number of callipers per wheel g3) Matériau des étriers Caliper material g4) Epaisseur maximale du disque Maximum disc thickness g5) Diamètre extérieur du disque Exterior diameter of the disc g6) Diamètre extérieur de frottement des sabots Exterior diameter of the shoe's rubbing surface g7) Diamètre intérieur de frottement des sabots Interior diameter of the shoe's rubbing surface g8) Longueur hors-tout des sabots Overall length of the shoes g9) Disques ventilés Ventilated disc g10) Surface de freinage par roue Braking surface per wheel	<table border="1"> <thead> <tr> <th>Avent / Front</th> <th>Arrière / Rear</th> </tr> </thead> <tbody> <tr> <td>4</td> <td>4</td> </tr> <tr> <td>38,1 et 41,2 mm</td> <td>38,1 et 41,2 mm</td> </tr> <tr> <td>_____ mm (± 1.5 mm)</td> <td>_____ mm (± 1.5 mm)</td> </tr> <tr> <td>_____ cm<sup>2</sup></td> <td>_____ cm<sup>2</sup></td> </tr> <tr> <td>_____ mm</td> <td>_____ mm</td> </tr> <tr> <td>2</td> <td>2</td> </tr> <tr> <td>1</td> <td>1</td> </tr> </tbody> </table>	Avent / Front	Arrière / Rear	4	4	38,1 et 41,2 mm	38,1 et 41,2 mm	_____ mm (± 1.5 mm)	_____ mm (± 1.5 mm)	_____ cm <sup>2</sup>	_____ cm <sup>2</sup>	_____ mm	_____ mm	2	2	1	1	<table border="1"> <thead> <tr> <th>AV / Front</th> <th>AR / Rear</th> </tr> </thead> <tbody> <tr> <td>alu</td> <td>alu</td> </tr> <tr> <td>28 mm</td> <td>28 mm</td> </tr> <tr> <td>300 mm (± 1 mm)</td> <td>300 mm (± 1 mm)</td> </tr> <tr> <td>300 mm</td> <td>300 mm</td> </tr> <tr> <td>195 mm</td> <td>195 mm</td> </tr> <tr> <td>126,5 mm</td> <td>126,5 mm</td> </tr> <tr> <td>Oui/yes yes/yes</td> <td>Oui/yes yes/yes</td> </tr> <tr> <td>816 cm<sup>2</sup></td> <td>816 cm<sup>2</sup></td> </tr> </tbody> </table>	AV / Front	AR / Rear	alu	alu	28 mm	28 mm	300 mm (± 1 mm)	300 mm (± 1 mm)	300 mm	300 mm	195 mm	195 mm	126,5 mm	126,5 mm	Oui/yes yes/yes	Oui/yes yes/yes	816 cm <sup>2</sup>	816 cm <sup>2</sup>
Avent / Front	Arrière / Rear																																					
4	4																																					
38,1 et 41,2 mm	38,1 et 41,2 mm																																					
_____ mm (± 1.5 mm)	_____ mm (± 1.5 mm)																																					
_____ cm <sup>2</sup>	_____ cm <sup>2</sup>																																					
_____ mm	_____ mm																																					
2	2																																					
1	1																																					
AV / Front	AR / Rear																																					
alu	alu																																					
28 mm	28 mm																																					
300 mm (± 1 mm)	300 mm (± 1 mm)																																					
300 mm	300 mm																																					
195 mm	195 mm																																					
126,5 mm	126,5 mm																																					
Oui/yes yes/yes	Oui/yes yes/yes																																					
816 cm <sup>2</sup>	816 cm <sup>2</sup>																																					



*Signature*



# FEDERATION INTERNATIONALE DU SPORT AUTOMOBILE

Homologation N°

B 262

Extension N°

22 - 05 ER

FICHE D'EXTENSION A L'HOMOLOGATION OFFICIELLE FISA  
FORM OF EXTENSION TO THE OFFICIAL FISA HOMOLOGATION

- ES Evolution sportive du type / Sporting evolution of the type
- ET Evolution normale du type / Normal evolution of the type
- VF Variante de fourniture / Supply variant
- VO Variante option / Option variant
- ER Errata / Erratum

Homologation valable dès le \_\_\_\_\_ en groupe B  
Homologation valid as from \_\_\_\_\_ in group B

Constructeur PEUGEOT Modèle et type 205 TURBO 16  
Manufacturer PEUGEOT Model and type 205 TURBO 16

Page ou ext. Page or ext.	Art. Art.	Description Description	Photo 1	Photo 3																																		
05 -03-V0	803	e) Nombre de cylindres par roue: Number of cylinders per wheel: e1) Alésage Bore f) Freins à tambours: Drum brakes: f1) Diamètre intérieur Interior diameter f2) Nombre de mâchoires par roue. Number of shoes per wheel f3) Surface de freinage Braking surface f4) Largeur des garnitures Width of the shoes g) Freins à disques: Disc brakes: g1) Nombre de sabots par roue Number of pads per wheel g2) Nombre d'étriers par roue Number of calipers per wheel	<table border="1"> <thead> <tr> <th>Avant / Front</th> <th>Arrière / Rear</th> </tr> </thead> <tbody> <tr> <td>4</td> <td>4</td> </tr> <tr> <td>38,1 et 41,2 mm</td> <td>38,1 et 41,2 mm</td> </tr> <tr> <td>_____ mm (± 1,5 mm)</td> <td>_____ mm (± 1,5 mm)</td> </tr> <tr> <td>_____ cm<sup>2</sup></td> <td>_____ cm<sup>2</sup></td> </tr> <tr> <td>_____ mm</td> <td>_____ mm</td> </tr> <tr> <td>2</td> <td>2</td> </tr> <tr> <td>1</td> <td>1</td> </tr> </tbody> </table>	Avant / Front	Arrière / Rear	4	4	38,1 et 41,2 mm	38,1 et 41,2 mm	_____ mm (± 1,5 mm)	_____ mm (± 1,5 mm)	_____ cm <sup>2</sup>	_____ cm <sup>2</sup>	_____ mm	_____ mm	2	2	1	1	<table border="1"> <thead> <tr> <th>AV / Front</th> <th>AR / Rear</th> </tr> </thead> <tbody> <tr> <td>alu</td> <td>alu</td> </tr> <tr> <td>25,8 mm</td> <td>25,8 mm</td> </tr> <tr> <td>278 mm (± 1 mm)</td> <td>278 mm (± 1 mm)</td> </tr> <tr> <td>278 mm</td> <td>278 mm</td> </tr> <tr> <td>184 mm</td> <td>184 mm</td> </tr> <tr> <td>126,5 mm</td> <td>126,5 mm</td> </tr> <tr> <td>oui/yes oui/yes</td> <td>oui/yes oui/yes</td> </tr> <tr> <td>682 cm<sup>2</sup></td> <td>682 cm<sup>2</sup></td> </tr> </tbody> </table>	AV / Front	AR / Rear	alu	alu	25,8 mm	25,8 mm	278 mm (± 1 mm)	278 mm (± 1 mm)	278 mm	278 mm	184 mm	184 mm	126,5 mm	126,5 mm	oui/yes oui/yes	oui/yes oui/yes	682 cm <sup>2</sup>	682 cm <sup>2</sup>
Avant / Front	Arrière / Rear																																					
4	4																																					
38,1 et 41,2 mm	38,1 et 41,2 mm																																					
_____ mm (± 1,5 mm)	_____ mm (± 1,5 mm)																																					
_____ cm <sup>2</sup>	_____ cm <sup>2</sup>																																					
_____ mm	_____ mm																																					
2	2																																					
1	1																																					
AV / Front	AR / Rear																																					
alu	alu																																					
25,8 mm	25,8 mm																																					
278 mm (± 1 mm)	278 mm (± 1 mm)																																					
278 mm	278 mm																																					
184 mm	184 mm																																					
126,5 mm	126,5 mm																																					
oui/yes oui/yes	oui/yes oui/yes																																					
682 cm <sup>2</sup>	682 cm <sup>2</sup>																																					
		g3) Matériau des étriers Caliper material g4) Epaisseur maximale du disque Maximum disc thickness g5) Diamètre extérieur du disque Exterior diameter of the disc g6) Diamètre extérieur de frottement des sabots Exterior diameter of the shoe's rubbing surface g7) Diamètre intérieur de frottement des sabots Interior diameter of the shoe's rubbing surface g8) Longueur hors-tout des sabots Overall length of the shoes g9) Disques ventilés Ventilated disc g10) Surface de freinage par roue Braking surface per wheel																																				





# FEDERATION INTERNATIONALE DU SPORT AUTOMOBILE

Homologation N°

B 262

Extension N°

**22 - 05 ER**

FICHE D'EXTENSION A L'HOMOLOGATION OFFICIELLE FISA  
FORM OF EXTENSION TO THE OFFICIAL FISA HOMOLOGATION

- ES Evolution sportive du type / Sporting evolution of the type
- ET Evolution normale du type / Normal evolution of the type
- VF Variante de fourniture / Supply variant
- VO Variante option / Option variant
- ER Errata / Erratum

Homologation valable dès le \_\_\_\_\_ en groupe B  
Homologation valid as from \_\_\_\_\_ in group B

Constructeur PEUGEOT Modèle et type 205 TURBO 16  
Manufacturer PEUGEOT Model and type 205 TURBO 16

Page ou ext. Page or ext.	Art. Art.	Description Description	Frein outbord et/ou inbord accolés aux ponts AV et AR Photo 1	Photo 3																																		
05-03-V0	803	e) Nombre de cylindres par roue: Number of cylinders per wheel: e1) Alésage Bore f) Freins à tambours: Drum brakes: f1) Diamètre intérieur Interior diameter f2) Nombre de mâchoires par roue. Number of shoes per wheel f3) Surface de freinage Braking surface f4) Largeur des garnitures Width of the shoes g) Freins à disques: Disc brakes: g1) Nombre de sabots par roue Number of pads per wheel g2) Nombre d'étriers par roue Number of callipers per wheel	<table border="1"> <thead> <tr> <th>Avant / Front</th> <th>Arrière / Rear</th> </tr> </thead> <tbody> <tr> <td>4</td> <td>4</td> </tr> <tr> <td>38,1 et 41,2 mm</td> <td>38,1 et 41,2 mm</td> </tr> <tr> <td>_____ mm (± 1.5 mm)</td> <td>_____ mm (± 1.5 mm)</td> </tr> <tr> <td>_____ cm²</td> <td>_____ cm²</td> </tr> <tr> <td>_____ mm</td> <td>_____ mm</td> </tr> <tr> <td>2</td> <td>2</td> </tr> <tr> <td>1</td> <td>1</td> </tr> </tbody> </table>	Avant / Front	Arrière / Rear	4	4	38,1 et 41,2 mm	38,1 et 41,2 mm	_____ mm (± 1.5 mm)	_____ mm (± 1.5 mm)	_____ cm²	_____ cm²	_____ mm	_____ mm	2	2	1	1	<table border="1"> <thead> <tr> <th>AV / Front</th> <th>AR / Rear</th> </tr> </thead> <tbody> <tr> <td>Alu</td> <td>Alu</td> </tr> <tr> <td>28 mm</td> <td>28 mm</td> </tr> <tr> <td>278 mm (± 1 mm)</td> <td>278 mm (± 1 mm)</td> </tr> <tr> <td>278 mm</td> <td>278 mm</td> </tr> <tr> <td>184 mm</td> <td>184 mm</td> </tr> <tr> <td>126,5 mm</td> <td>126,5 mm</td> </tr> <tr> <td>Oui/Non yes/no</td> <td>Oui/Non yes/no</td> </tr> <tr> <td>682 cm²</td> <td>682 cm²</td> </tr> </tbody> </table>	AV / Front	AR / Rear	Alu	Alu	28 mm	28 mm	278 mm (± 1 mm)	278 mm (± 1 mm)	278 mm	278 mm	184 mm	184 mm	126,5 mm	126,5 mm	Oui/Non yes/no	Oui/Non yes/no	682 cm²	682 cm²
Avant / Front	Arrière / Rear																																					
4	4																																					
38,1 et 41,2 mm	38,1 et 41,2 mm																																					
_____ mm (± 1.5 mm)	_____ mm (± 1.5 mm)																																					
_____ cm²	_____ cm²																																					
_____ mm	_____ mm																																					
2	2																																					
1	1																																					
AV / Front	AR / Rear																																					
Alu	Alu																																					
28 mm	28 mm																																					
278 mm (± 1 mm)	278 mm (± 1 mm)																																					
278 mm	278 mm																																					
184 mm	184 mm																																					
126,5 mm	126,5 mm																																					
Oui/Non yes/no	Oui/Non yes/no																																					
682 cm²	682 cm²																																					
		g3) Matériau des étriers Calliper material g4) Epaisseur maximale du disque Maximum disc thickness g5) Diamètre extérieur du disque Exterior diameter of the disc g6) Diamètre extérieur de frottement des sabots Exterior diameter of the shoe's rubbing surface g7) Diamètre intérieur de frottement des sabots Interior diameter of the shoe's rubbing surface g8) Longueur hors-tout des sabots Overall length of the shoes g9) Disques ventilés Ventilated disc g10) Surface de freinage par roue Braking surface per wheel																																				







# FEDERATION INTERNATIONALE DU SPORT AUTOMOBILE

Homologation N°

B 262

Extension N°

22 - 05 ER

FICHE D'EXTENSION A L'HOMOLOGATION OFFICIELLE FISA  
FORM OF EXTENSION TO THE OFFICIAL FISA HOMOLOGATION

- ES Evolution sportive du type / Sporting evolution of the type
- ET Evolution normale du type / Normal evolution of the type
- VF Variante de fourniture / Supply variant
- VO Variante option / Option variant
- ER Errata / Erratum

Homologation valable dès le \_\_\_\_\_ en groupe B  
Homologation valid as from \_\_\_\_\_ in group B

Constructeur PEUGEOT Modèle et type 205 TURBO 16  
Manufacturer Manufacturer Model and type

Page ou ext. Art. Description Frein outbord et/ou inbord accolés aux ponts AV et AR  
Page or ext. Art. Description

05-03-V0

803

e) Nombre de cylindres par roue:  
Number of cylinders per wheel:

e1) Alésage

Bore

f) Freins à tambours:

Drum brakes:

f1) Diamètre intérieur

Interior diameter

f2) Nombre de mâchoires par roue.

Number of shoes per wheel

f3) Surface de freinage

Braking surface

f4) Largeur des garnitures

Width of the shoes

g) Freins à disques:

Disc brakes:

g1) Nombre de sabots par roue

Number of pads per wheel

g2) Nombre d'étriers par roue

Number of calipers per wheel

g3) Matériau des étriers

Caliper material

g4) Epaisseur maximale du disque

Maximum disc thickness

g5) Diamètre extérieur du disque

Exterior diameter of the disc

g6) Diamètre extérieur de

frottement des sabots

Exterior diameter of the

shoe's rubbing surface

g7) Diamètre intérieur de

frottement des sabots

Interior diameter of the

shoe's rubbing surface

g8) Longueur hors-tout des sabots

Overall length of the shoes

g9) Disques ventilés

Ventilated disc

g10) Surface de freinage par roue

Braking surface per wheel

		Avant / Front	Arrière / Rear
		4	4
		38,1 et 41,2 mm	38,1 et 41,2 mm
		mm (± 1.5 mm)	mm (± 1.5 mm)
		cm <sup>2</sup>	cm <sup>2</sup>
		mm	mm
		2	2
		1	1
		AV / Front	AR / Rear
		alu	alu
		25,8 mm	25,8 mm
		300 mm (± 1 mm)	300 mm (± 1 mm)
		300 mm	300 mm
		195 mm	195 mm
		126,5 mm	126,5 mm
		oui/non yes/no	oui/non yes/no
		816 cm <sup>2</sup>	816 cm <sup>2</sup>





# FEDERATION INTERNATIONALE DU SPORT AUTOMOBILE

Homologation N°

B 262

Extension N°

22-05 ER

FICHE D'EXTENSION A L'HOMOLOGATION OFFICIELLE FISA  
FORM OF EXTENSION TO THE OFFICIAL FISA HOMOLOGATION

- ES Evolution sportive du type / Sporting evolution of the type
- ET Evolution normale du type / Normal evolution of the type
- VF Variante de fourniture / Supply variant
- VO Variante option / Option variant
- ER Errata / Erratum

Homologation valable dès le \_\_\_\_\_ en groupe \_\_\_\_\_  
Homologation valid as from \_\_\_\_\_ in group B

Constructeur PEUGEOT Modèle et type 205 TURBO 16  
Manufacturer \_\_\_\_\_ Model and type \_\_\_\_\_

Page ou ext. Page or ext.	Art. Art.	Description Description	Frein outbord et/ou inbord accolés aux pont AV et AR Photo 21-22-23-24	Photo 21-22-23-24																																																																
08-05-VO	803	e) Nombre de cylindres par roue: Number of cylinders per wheel: e1) Alésage Bore f) Freins à tambours: Drum brakes: f1) Diamètre intérieur Interior diameter f2) Nombre de mâchoires par roue. Number of shoes per wheel f3) Surface de freinage Braking surface f4) Largeur des garnitures Width of the shoes g) Freins à disques: Disc brakes: g1) Nombres de sabots par roue Number of pads per wheel g2) Nombre d'étriers par roue Number of calipers per wheel  g3) Matériau des étriers Caliper material g4) Epaisseur maximale du disque Maximum disc thickness g5) Diamètre extérieur du disque Exterior diameter of the disc g6) Diamètre extérieur de frottement des sabots Exterior diameter of the shoe's rubbing surface g7) Diamètre intérieur de frottement des sabots Interior diameter of the shoe's rubbing surface g8) Longueur hors-tout des sabots Overall length of the shoes g9) Disques ventilés Ventilated disc g10) Surface de freinage par roue Braking surface per wheel	<table border="1"> <thead> <tr> <th>Avant / Front</th> <th>Arrière / Rear</th> </tr> </thead> <tbody> <tr> <td>4</td> <td>4</td> </tr> <tr> <td>41,2 mm</td> <td>41,2 mm</td> </tr> <tr> <td>_____ mm (± 1,5 mm)</td> <td>_____ mm (± 1,5 mm)</td> </tr> <tr> <td>_____ cm<sup>2</sup></td> <td>_____ cm<sup>2</sup></td> </tr> <tr> <td>_____ mm</td> <td>_____ mm</td> </tr> <tr> <td>2</td> <td>2</td> </tr> <tr> <td>1</td> <td>1</td> </tr> </tbody> </table> <table border="1"> <thead> <tr> <th>AV / Front</th> <th>AR / Rear</th> </tr> </thead> <tbody> <tr> <td>alu + magnésium</td> <td>alu + magnésium</td> </tr> <tr> <td>28,2 mm</td> <td>28,2 mm</td> </tr> <tr> <td>278 mm (± 1 mm)</td> <td>278 mm (± 1 mm)</td> </tr> <tr> <td>278 mm</td> <td>278 mm</td> </tr> <tr> <td>184 mm</td> <td>184 mm</td> </tr> <tr> <td>127 mm</td> <td>127 mm</td> </tr> <tr> <td>oui/non yes/no 682 cm<sup>2</sup></td> <td>oui/non yes/no 682 cm<sup>2</sup></td> </tr> </tbody> </table>	Avant / Front	Arrière / Rear	4	4	41,2 mm	41,2 mm	_____ mm (± 1,5 mm)	_____ mm (± 1,5 mm)	_____ cm <sup>2</sup>	_____ cm <sup>2</sup>	_____ mm	_____ mm	2	2	1	1	AV / Front	AR / Rear	alu + magnésium	alu + magnésium	28,2 mm	28,2 mm	278 mm (± 1 mm)	278 mm (± 1 mm)	278 mm	278 mm	184 mm	184 mm	127 mm	127 mm	oui/non yes/no 682 cm <sup>2</sup>	oui/non yes/no 682 cm <sup>2</sup>	<table border="1"> <thead> <tr> <th>Avant / Front</th> <th>Arrière / Rear</th> </tr> </thead> <tbody> <tr> <td>4</td> <td>4</td> </tr> <tr> <td>41,2 mm</td> <td>41,2 mm</td> </tr> <tr> <td>_____ mm (± 1,5 mm)</td> <td>_____ mm (± 1,5 mm)</td> </tr> <tr> <td>_____ cm<sup>2</sup></td> <td>_____ cm<sup>2</sup></td> </tr> <tr> <td>_____ mm</td> <td>_____ mm</td> </tr> <tr> <td>2</td> <td>2</td> </tr> <tr> <td>1</td> <td>1</td> </tr> </tbody> </table> <table border="1"> <thead> <tr> <th>AV / Front</th> <th>AR / Rear</th> </tr> </thead> <tbody> <tr> <td>alu + magnésium</td> <td>alu + magnésium</td> </tr> <tr> <td>28,2 mm</td> <td>28,2 mm</td> </tr> <tr> <td>278 mm (± 1 mm)</td> <td>278 mm (± 1 mm)</td> </tr> <tr> <td>278 mm</td> <td>278 mm</td> </tr> <tr> <td>184 mm</td> <td>184 mm</td> </tr> <tr> <td>127 mm</td> <td>127 mm</td> </tr> <tr> <td>oui/non yes/no 682 cm<sup>2</sup></td> <td>oui/non yes/no 682 cm<sup>2</sup></td> </tr> </tbody> </table>	Avant / Front	Arrière / Rear	4	4	41,2 mm	41,2 mm	_____ mm (± 1,5 mm)	_____ mm (± 1,5 mm)	_____ cm <sup>2</sup>	_____ cm <sup>2</sup>	_____ mm	_____ mm	2	2	1	1	AV / Front	AR / Rear	alu + magnésium	alu + magnésium	28,2 mm	28,2 mm	278 mm (± 1 mm)	278 mm (± 1 mm)	278 mm	278 mm	184 mm	184 mm	127 mm	127 mm	oui/non yes/no 682 cm <sup>2</sup>	oui/non yes/no 682 cm <sup>2</sup>
Avant / Front	Arrière / Rear																																																																			
4	4																																																																			
41,2 mm	41,2 mm																																																																			
_____ mm (± 1,5 mm)	_____ mm (± 1,5 mm)																																																																			
_____ cm <sup>2</sup>	_____ cm <sup>2</sup>																																																																			
_____ mm	_____ mm																																																																			
2	2																																																																			
1	1																																																																			
AV / Front	AR / Rear																																																																			
alu + magnésium	alu + magnésium																																																																			
28,2 mm	28,2 mm																																																																			
278 mm (± 1 mm)	278 mm (± 1 mm)																																																																			
278 mm	278 mm																																																																			
184 mm	184 mm																																																																			
127 mm	127 mm																																																																			
oui/non yes/no 682 cm <sup>2</sup>	oui/non yes/no 682 cm <sup>2</sup>																																																																			
Avant / Front	Arrière / Rear																																																																			
4	4																																																																			
41,2 mm	41,2 mm																																																																			
_____ mm (± 1,5 mm)	_____ mm (± 1,5 mm)																																																																			
_____ cm <sup>2</sup>	_____ cm <sup>2</sup>																																																																			
_____ mm	_____ mm																																																																			
2	2																																																																			
1	1																																																																			
AV / Front	AR / Rear																																																																			
alu + magnésium	alu + magnésium																																																																			
28,2 mm	28,2 mm																																																																			
278 mm (± 1 mm)	278 mm (± 1 mm)																																																																			
278 mm	278 mm																																																																			
184 mm	184 mm																																																																			
127 mm	127 mm																																																																			
oui/non yes/no 682 cm <sup>2</sup>	oui/non yes/no 682 cm <sup>2</sup>																																																																			





# FEDERATION INTERNATIONALE DU SPORT AUTOMOBILE

Homologation N°

B 262

Extension N°

22 - 05 ER

FICHE D'EXTENSION A L'HOMOLOGATION OFFICIELLE FISA  
FORM OF EXTENSION TO THE OFFICIAL FISA HOMOLOGATION

- ES Evolution sportive du type / Sporting evolution of the type
- ET Evolution normale du type / Normal evolution of the type
- VF Variante de fourniture / Supply variant
- VO Variante option / Option variant
- ER Errata / Erratum

Homologation valable dès le \_\_\_\_\_ en groupe  
Homologation valid as from \_\_\_\_\_ in group B

Constructeur PEUGEOT Modèle et type 205 TURBO 16  
Manufacturer \_\_\_\_\_ Model and type \_\_\_\_\_

Page ou ext. \_\_\_\_\_ Art. \_\_\_\_\_ Description Frein outbord et/ou inbord accolés aux pont AV et AR  
Page or ext. \_\_\_\_\_ Art. \_\_\_\_\_ Description Photo 21-22-23-24 Photo 21-22-23-24

Page ou ext. Page or ext.	Art. Art.	Description	Avant / Front		Arrière / Rear	
08-05-VO	803	e) Nombre de cylindres par roue: Number of cylinders per wheel: e1) Alésage Bore f) Freins à tambours: Drum brakes: f1) Diamètre intérieur Interior diameter f2) Nombre de mâchoires par roue. Number of shoes per wheel f3) Surface de freinage Braking surface f4) Largeur des garnitures Width of the shoes g) Freins à disques: Disc brakes: g1) Nombre de sabots par roue Number of pads per wheel g2) Nombre d'étriers par roue Number of calipers per wheel	8 41,2 mm	8 41,2 mm	8 41,2 mm	8 41,2 mm
		g3) Matériau des étriers Caliper material g4) Epaisseur maximale du disque Maximum disc thickness g5) Diamètre extérieur du disque Exterior diameter of the disc g6) Diamètre extérieur de frottement des sabots Exterior diameter of the shoe's rubbing surface g7) Diamètre intérieur de frottement des sabots Interior diameter of the shoe's rubbing surface g8) Longueur hors-tout des sabots Overall length of the shoes g9) Disques ventilés Ventilated disc g10) Surface de freinage par roue Braking surface per wheel	4 2	4 2	4 2	4 2
			AV / Front	AR / Rear	AV / Front	AR / Rear
			alu + magnésium	alu + magnésium	alu + magnésium	alu + magnésium
			28,2 mm	28,2 mm	28,2 mm	28,2 mm
			278 mm (± 1 mm)	278 mm (± 1 mm)	278 mm (± 1 mm)	278 mm (± 1 mm)
			278 mm	278 mm	278 mm	278 mm
			184 mm	184 mm	184 mm	184 mm
			127 mm	127 mm	127 mm	127 mm
			oui/yes yes/yes	oui/yes yes/yes	oui/yes yes/yes	oui/yes yes/yes
			682 cm²	682 cm²	682 cm²	682 cm²





# FEDERATION INTERNATIONALE DU SPORT AUTOMOBILE

Homologation N°

B 262

Extension N°

22-05 ER

FICHE D'EXTENSION A L'HOMOLOGATION OFFICIELLE FISA  
FORM OF EXTENSION TO THE OFFICIAL FISA HOMOLOGATION

- ES Evolution sportive du type / Sporting evolution of the type
- ET Evolution normale du type / Normal evolution of the type
- VF Variante de fourniture / Supply variant
- VO Variante option / Option variant
- ER Errata / Erratum

Homologation valable dès le \_\_\_\_\_ en groupe  
Homologation valid as from \_\_\_\_\_ in group B

Constructeur PEUGEOT Modèle et type 205 TURBO 16  
Manufacturer \_\_\_\_\_ Model and type \_\_\_\_\_

Page ou ext. Page or ext.	Art. Art.	Description Description	Avant / Front	Arrière / Rear
08-05-VO	803	Frein outbord et/ou inbord accolés aux pont AV et AR Photo 21-22-23-24 Photo 21-22-23-24		
		e) Nombre de cylindres par roue: Number of cylinders per wheel: e1) Alésage Bore f) Freins à tambours: Drum brakes: f1) Diamètre intérieur Interior diameter f2) Nombre de mâchoires par roue. Number of shoes per wheel f3) Surface de freinage Braking surface f4) Largeur des garnitures Width of the shoes g) Freins à disques: Disc brakes: g1) Nombre de sabots par roue Number of pads per wheel g2) Nombre d'étriers par roue Number of calipers per wheel	8 41,2 mm	8 41,2 mm
			_____ mm (± 1.5 mm)	_____ mm (± 1.5 mm)
			_____ cm²	_____ cm²
			_____ mm	_____ mm
			4	4
			2	2
		g3) Matériau des étriers Caliper material g4) Epaisseur maximale du disque Maximum disc thickness g5) Diamètre extérieur du disque Exterior diameter of the disc g6) Diamètre extérieur de frottement des sabots Exterior diameter of the shoe's rubbing surface g7) Diamètre intérieur de frottement des sabots Interior diameter of the shoe's rubbing surface g8) Longueur hors-tout des sabots Overall length of the shoes g9) Disques ventilés Ventilated disc g10) Surface de freinage par roue Braking surface per wheel	aluminium + magnésium 28,2 mm 303 mm (± 1 mm) 303 mm 205 mm 131 mm oui/yes 782 cm²	aluminium + magnésium 28,2 mm 303 mm (± 1 mm) 303 mm 205 mm 131 mm oui/yes 782 cm²





# FEDERATION INTERNATIONALE DU SPORT AUTOMOBILE

Homologation N°

B 262

Extension N°

22-05 ER

## FICHE D'EXTENSION A L'HOMOLOGATION OFFICIELLE FISA FORM OF EXTENSION TO THE OFFICIAL FISA HOMOLOGATION

- ES Evolution sportive du type / Sporting evolution of the type
- ET Evolution normale du type / Normal evolution of the type
- VF Variante de fourniture / Supply variant
- VO Variante option / Option variant
- ER Errata / Erratum

Homologation valable dès le \_\_\_\_\_ en groupe  
Homologation valid as from \_\_\_\_\_ in group B

Constructeur PEUGEOT Modèle et type 205 TURBO 16  
Manufacturer PEUGEOT Model and type 205 TURBO 16

Page ou ext. Page or ext.	Art. Art.	Description Description	Frein outbord et/ou inbord accolés aux pont AV et AR Photo 21-22-23-24	Photo 21-22-23-24																																		
08-05-VO	803	e) Nombre de cylindres par roue: Number of cylinders per wheel: e1) Alésage Bore f) Freins à tambours: Drum brakes: f1) Diamètre intérieur Interior diameter f2) Nombre de mâchoires par roue. Number of shoes per wheel f3) Surface de freinage Braking surface f4) Largeur des garnitures Width of the shoes g) Freins à disques: Disc brakes: g1) Nombre de sabots par roue Number of pads per wheel g2) Nombre d'étriers par roue Number of callipers per wheel g3) Matériau des étriers Caliper material g4) Epaisseur maximale du disque Maximum disc thickness g5) Diamètre extérieur du disque Exterior diameter of the disc g6) Diamètre extérieur de frottement des sabots Exterior diameter of the shoe's rubbing surface g7) Diamètre intérieur de frottement des sabots Interior diameter of the shoe's rubbing surface g8) Longueur hors-tout des sabots Overall length of the shoes g9) Disques ventilés Vented disc g10) Surface de freinage par roue Braking surface per wheel	<table border="1"> <thead> <tr> <th>Avant / Front</th> <th>Arrière / Rear</th> </tr> </thead> <tbody> <tr> <td>4</td> <td>4</td> </tr> <tr> <td>41,2 mm</td> <td>41,2 mm</td> </tr> <tr> <td>mm (± 1.5 mm)</td> <td>mm (± 1.5 mm)</td> </tr> <tr> <td>cm<sup>2</sup></td> <td>cm<sup>2</sup></td> </tr> <tr> <td>mm</td> <td>mm</td> </tr> <tr> <td>2</td> <td>2</td> </tr> <tr> <td>1</td> <td>1</td> </tr> </tbody> </table>	Avant / Front	Arrière / Rear	4	4	41,2 mm	41,2 mm	mm (± 1.5 mm)	mm (± 1.5 mm)	cm <sup>2</sup>	cm <sup>2</sup>	mm	mm	2	2	1	1	<table border="1"> <thead> <tr> <th>AV / Front</th> <th>AR / Rear</th> </tr> </thead> <tbody> <tr> <td>alu + magnésium</td> <td>alu + magnésium</td> </tr> <tr> <td>28,2 mm</td> <td>28,2 mm</td> </tr> <tr> <td>303 mm (± 1 mm)</td> <td>303 mm (± 1 mm)</td> </tr> <tr> <td>303 mm</td> <td>303 mm</td> </tr> <tr> <td>205 mm</td> <td>205 mm</td> </tr> <tr> <td>131 mm</td> <td>131 mm</td> </tr> <tr> <td>oui/yes</td> <td>oui/yes</td> </tr> <tr> <td>782 cm<sup>2</sup></td> <td>782 cm<sup>2</sup></td> </tr> </tbody> </table>	AV / Front	AR / Rear	alu + magnésium	alu + magnésium	28,2 mm	28,2 mm	303 mm (± 1 mm)	303 mm (± 1 mm)	303 mm	303 mm	205 mm	205 mm	131 mm	131 mm	oui/yes	oui/yes	782 cm <sup>2</sup>	782 cm <sup>2</sup>
Avant / Front	Arrière / Rear																																					
4	4																																					
41,2 mm	41,2 mm																																					
mm (± 1.5 mm)	mm (± 1.5 mm)																																					
cm <sup>2</sup>	cm <sup>2</sup>																																					
mm	mm																																					
2	2																																					
1	1																																					
AV / Front	AR / Rear																																					
alu + magnésium	alu + magnésium																																					
28,2 mm	28,2 mm																																					
303 mm (± 1 mm)	303 mm (± 1 mm)																																					
303 mm	303 mm																																					
205 mm	205 mm																																					
131 mm	131 mm																																					
oui/yes	oui/yes																																					
782 cm <sup>2</sup>	782 cm <sup>2</sup>																																					





# FEDERATION INTERNATIONALE DU SPORT AUTOMOBILE

Homologation N°

B 262

Extension N°

22-05 ER

## FICHE D'EXTENSION A L'HOMOLOGATION OFFICIELLE FISA FORM OF EXTENSION TO THE OFFICIAL FISA HOMOLOGATION

- ES Evolution sportive du type / Sporting evolution of the type
- ET Evolution normale du type / Normal evolution of the type
- VF Variante de fourniture / Supply variant
- VO Variante option / Option variant
- ER Errata / Erratum

Homologation valable dès le \_\_\_\_\_ en groupe B  
Homologation valid as from \_\_\_\_\_ in group

Constructeur PEUGEOT Modèle et type 205 TURBO 16  
Manufacturer PEUGEOT Model and type 205 TURBO 16

Page ou ext. Page or ext.	Art. Art.	Description Description	Avant / Front	Arrière / Rear
13-09-VO	803	<p>e) Nombre de cylindres par roue: Number of cylinders per wheel:</p> <p>e1) Alésage Bore</p> <p>f) Freins à tambours: Drum brakes:</p> <p>f1) Diamètre intérieur Interior diameter</p> <p>f2) Nombre de mâchoires par roue. Number of shoes per wheel</p> <p>f3) Surface de freinage Braking surface</p> <p>f4) Largeur des garnitures Width of the shoes</p> <p>g) Freins à disques: Disc brakes:</p> <p>g1) Nombre de sabots par roue Number of pads per wheel</p> <p>g2) Nombre d'étriers par roue Number of calipers per wheel</p> <p>g3) Matériau des étriers Caliper material</p> <p>g4) Epaisseur maximale du disque Maximum disc thickness</p> <p>g5) Diamètre extérieur du disque Exterior diameter of the disc</p> <p>g6) Diamètre extérieur de frottement des sabots Exterior diameter of the shoe's rubbing surface</p> <p>g7) Diamètre intérieur de frottement des sabots Interior diameter of the shoe's rubbing surface</p> <p>g8) Longueur hors-tout des sabots Overall length of the shoes</p> <p>g9) Disques ventilés Ventilated disc</p> <p>g10) Surface de freinage par roue Braking surface per wheel</p>	<p>8</p> <p>38,1 et 38,1 mm</p> <p>mm (± 1.5 mm)</p> <p>cm<sup>2</sup></p> <p>mm</p> <p>2</p> <p>1</p> <p>alu + magnésium</p> <p>mm</p> <p>mm (± 1 mm)</p> <p>mm</p> <p>mm</p> <p>mm</p> <p>mm</p> <p>oui/non yes/no</p> <p>cm<sup>2</sup></p>	<p>8</p> <p>38,1 et 38,1 mm</p> <p>mm (± 1.5 mm)</p> <p>cm<sup>2</sup></p> <p>mm</p> <p>2</p> <p>1</p> <p>alu + magnésium</p> <p>mm</p> <p>mm (± 1 mm)</p> <p>mm</p> <p>mm</p> <p>mm</p> <p>mm</p> <p>oui/non yes/no</p> <p>cm<sup>2</sup></p>
			AV / Front	AR / Rear





# FEDERATION INTERNATIONALE DU SPORT AUTOMOBILE

Homologation N°

B 262

Extension N°

22-05 ER

## FICHE D'EXTENSION A L'HOMOLOGATION OFFICIELLE FISA FORM OF EXTENSION TO THE OFFICIAL FISA HOMOLOGATION

- ES Evolution sportive du type / Sporting evolution of the type
- ET Evolution normale du type / Normal evolution of the type
- VF Variante de fourniture / Supply variant
- VO Variante option / Option variant
- ER Errata / Erratum

Homologation valable dès le \_\_\_\_\_ en groupe B  
Homologation valid as from \_\_\_\_\_ in group B

Constructeur PEUGEOT Modèle et type 205 TURBO 16  
Manufacturer Model and type

Page ou ext. Page or ext.	Art. Art.	Description Description	Avant / Front	Arrière / Rear
13-09-VO	803	e) Nombre de cylindres par roue: Number of cylinders per wheel: e1) Alésage Bore f) Freins à tambours: Drum brakes: f1) Diamètre intérieur Interior diameter f2) Nombre de mâchoires par roue. Number of shoes per wheel f3) Surface de freinage Braking surface f4) Largeur des garnitures Width of the shoes g) Freins à disques: Disc brakes: g1) Nombre de sabots par roue Number of pads per wheel g2) Nombre d'étriers par roue Number of calipers per wheel	8 41,2 et 41,2 mm	8 41,2 et 41,2 mm
		f1) Diamètre intérieur Interior diameter f2) Nombre de mâchoires par roue. Number of shoes per wheel f3) Surface de freinage Braking surface f4) Largeur des garnitures Width of the shoes	_____ mm (± 1,5 mm)	_____ mm (± 1,5 mm)
		g1) Nombre de sabots par roue Number of pads per wheel g2) Nombre d'étriers par roue Number of calipers per wheel	4 2	4 2
		g3) Matériau des étriers Caliper material g4) Epaisseur maximale du disque Maximum disc thickness g5) Diamètre extérieur du disque Exterior diameter of the disc g6) Diamètre extérieur de frottement des sabots Exterior diameter of the shoe's rubbing surface g7) Diamètre intérieur de frottement des sabots Interior diameter of the shoe's rubbing surface g8) Longueur hors-tout des sabots Overall length of the shoes g9) Disques ventilés Ventilated disc g10) Surface de freinage par roue Braking surface per wheel	alu + magnésium _____ _____ _____ mm (± 1 mm)	alu + magnésium _____ _____ _____ mm (± 1 mm)
		g8) Longueur hors-tout des sabots Overall length of the shoes g9) Disques ventilés Ventilated disc g10) Surface de freinage par roue Braking surface per wheel	_____ mm oui/non yes/no _____ cm <sup>2</sup>	_____ mm oui/non yes/no _____ cm <sup>2</sup>





# FEDERATION INTERNATIONALE DU SPORT AUTOMOBILE

Homologation N°

B 262

Extension N°

22-05ER

FICHE D'EXTENSION A L'HOMOLOGATION OFFICIELLE FISA  
FORM OF EXTENSION TO THE OFFICIAL FISA HOMOLOGATION

- ES Evolution sportive du type / Sporting evolution of the type
- ET Evolution normale du type / Normal evolution of the type
- VF Variante de fourniture / Supply variant
- VO Variante option / Option variant
- ER Errata / Erratum

Homologation valable dès le \_\_\_\_\_ en groupe B  
Homologation valid as from \_\_\_\_\_ in group B

Constructeur PEUGEOT Modèle et type 205 TURBO 16  
Manufacturer Model and type

Page ou ext. Page or ext.	Art. Art.	Description Description	Avant / Front	Arrière / Rear
13-09-VO	803	<p>e) Nombre de cylindres par roue: Number of cylinders per wheel:</p> <p>e1) Alésage Bore</p> <p>f) Freins à tambours: Drum brakes:</p> <p>f1) Diamètre intérieur Interior diameter</p> <p>f2) Nombre de mâchoires par roue. Number of shoes per wheel</p> <p>f3) Surface de freinage Braking surface</p> <p>f4) Largeur des garnitures Width of the shoes</p> <p>g) Freins à disques: Disc brakes:</p> <p>g1) Nombre de sabots par roue Number of pads per wheel</p> <p>g2) Nombre d'étriers par roue Number of calipers per wheel</p> <p>g3) Matériau des étriers Caliper material</p> <p>g4) Epaisseur maximale du disque Maximum disc thickness</p> <p>g5) Diamètre extérieur du disque Exterior diameter of the disc</p> <p>g6) Diamètre extérieur de frottement des sabots Exterior diameter of the shoe's rubbing surface</p> <p>g7) Diamètre intérieur de frottement des sabots Interior diameter of the shoe's rubbing surface</p> <p>g8) Longueur hors-tout des sabots Overall length of the shoes</p> <p>g9) Disques ventilés Ventilated disc</p> <p>g10) Surface de freinage par roue Braking surface per wheel</p>	<p>4</p> <p>41,2 et 41,2 mm</p> <p>mm (± 1,5 mm)</p> <p>cm<sup>2</sup></p> <p>mm</p> <p>2</p> <p>1</p> <p>alu + magnésium</p> <p>mm</p> <p>mm (± 1 mm)</p> <p>mm</p> <p>mm</p> <p>mm</p> <p>mm</p> <p>oui/non yes/no</p> <p>cm<sup>2</sup></p>	<p>4</p> <p>41,2 et 41,2 mm</p> <p>mm (± 1,5 mm)</p> <p>cm<sup>2</sup></p> <p>mm</p> <p>2</p> <p>1</p> <p>alu + magnésium</p> <p>mm</p> <p>mm (± 1 mm)</p> <p>mm</p> <p>mm</p> <p>mm</p> <p>oui/non yes/no</p> <p>cm<sup>2</sup></p>







# FEDERATION INTERNATIONALE DU SPORT AUTOMOBILE

Homologation N°

B 262

Extension N°

22 - 05 ER

FICHE D'EXTENSION A L'HOMOLOGATION OFFICIELLE FISA  
FORM OF EXTENSION TO THE OFFICIAL FISA HOMOLOGATION

- ES Evolution sportive du type / Sporting evolution of the type
- ET Evolution normale du type / Normal evolution of the type
- VF Variante de fourniture / Supply variant
- VO Variante option / Option variant
- ER Errata / Erratum

Homologation valable dès le \_\_\_\_\_ en groupe B  
Homologation valid as from \_\_\_\_\_ in group B

Constructeur PEUGEOT Modèle et type 205 TURBO 16  
Manufacturer PEUGEOT Model and type 205 TURBO 16

Page ou ext. Art. Description Frein outbord et/ou inbord accolés aux ponts AV et AR  
Page or ext. Art. Description

13-09-VO

803

- e) Nombre de cylindres par roue:  
Number of cylinders per wheel:
- e1) Alésage  
Bore
- f) Freins à tambours:  
Drum brakes:
- f1) Diamètre intérieur  
Interior diameter
- f2) Nombre de mâchoires par roue  
Number of shoes per wheel
- f3) Surface de freinage  
Braking surface
- f4) Largeur des garnitures  
Width of the shoes
- g) Freins à disques:  
Disc brakes:
- g1) Nombres de sabots par roue  
Number of pads per wheel
- g2) Nombre d'étriers par roue  
Number of calipers per wheel

Avant / Front	Arrière / Rear
4	4
42 et 42 mm	42 et 42 mm
_____ mm (± 1,5 mm)	_____ mm (± 1,5 mm)
_____ cm <sup>2</sup>	_____ cm <sup>2</sup>
_____ mm	_____ mm
2	2
1	1

- g3) Matériau des étriers  
Caliper material
- g4) Epaisseur maximale du disque  
Maximum disc thickness
- g5) Diamètre extérieur du disque  
Exterior diameter of the disc
- g6) Diamètre extérieur de frottement des sabots  
Exterior diameter of the shoe's rubbing surface
- g7) Diamètre intérieur de frottement des sabots  
Interior diameter of the shoe's rubbing surface
- g8) Longueur hors-tout des sabots  
Overall length of the shoes
- g9) Disques ventilés  
Ventilated disc
- g10) Surface de freinage par roue  
Braking surface per wheel

AV / Front	AR / Rear
alu + magnésium	alu + magnésium
_____ mm	_____ mm
_____ mm (± 1 mm)	_____ mm (± 1 mm)
_____ mm	_____ mm
_____ mm	_____ mm
_____ mm	_____ mm
oui/non yes/no	oui/non yes/no
_____ cm <sup>2</sup>	_____ cm <sup>2</sup>





# FEDERATION INTERNATIONALE DU SPORT AUTOMOBILE

Homologation N°

B 262

Extension N°

22-05 ER

FICHE D'EXTENSION A L'HOMOLOGATION OFFICIELLE FISA  
FORM OF EXTENSION TO THE OFFICIAL FISA HOMOLOGATION

- ES Evolution sportive du type / Sporting evolution of the type
- ET Evolution normale du type / Normal evolution of the type
- VF Variante de fourniture / Supply variant
- VO Variante option / Option variant
- ER Errata / Erratum

Homologation valable dès le \_\_\_\_\_ en groupe B  
Homologation valid as from \_\_\_\_\_ in group B

Constructeur PEUGEOT Modèle et type 205 TURBO 16  
Manufacturier \_\_\_\_\_ Model and type \_\_\_\_\_

Page ou ext. 13-09-VO Art. 803 Description Frein outbord et/ou inbord accolés aux ponts AV et AR  
Page or ext. Art. Description

Page ou ext. Page or ext.	Art. Art.	Description Description	Avant / Front		Arrière / Rear	
			AV / Front		AR / Rear	
13-09-VO	803	e) Nombre de cylindres par roue: Number of cylinders per wheel:	8	8	8	8
		e1) Alésage Bore	42 et 42 mm	42 et 42 mm	42 et 42 mm	42 et 42 mm
		f) Freins à tambours: Drum brakes:				
		f1) Diamètre intérieur Interior diameter	_____ mm (± 1,5 mm)	_____ mm (± 1,5 mm)	_____ mm (± 1,5 mm)	_____ mm (± 1,5 mm)
		f2) Nombre de mâchoires par roue. Number of shoes per wheel	_____	_____	_____	_____
		f3) Surface de freinage Braking surface	_____ cm²	_____ cm²	_____ cm²	_____ cm²
		f4) Largeur des garnitures Width of the shoes	_____ mm	_____ mm	_____ mm	_____ mm
		g) Freins à disques: Disc brakes:				
		g1) Nombre de sabots par roue Number of pads per wheel	4	4	4	4
		g2) Nombre d'étriers par roue Number of calipers per wheel	2	2	2	2
		g3) Matériau des étriers Caliper material	alu + magnésium	alu + magnésium	alu + magnésium	alu + magnésium
		g4) Epaisseur maximale du disque Maximum disc thickness	_____ mm	_____ mm	_____ mm	_____ mm
		g5) Diamètre extérieur du disque Exterior diameter of the disc	_____ mm (± 1 mm)	_____ mm (± 1 mm)	_____ mm (± 1 mm)	_____ mm (± 1 mm)
		g6) Diamètre extérieur de frottement des sabots Exterior diameter of the shoe's rubbing surface	_____ mm	_____ mm	_____ mm	_____ mm
		g7) Diamètre intérieur de frottement des sabots Interior diameter of the shoe's rubbing surface	_____ mm	_____ mm	_____ mm	_____ mm
		g8) Longueur hors-tout des sabots Overall length of the shoes	_____ mm	_____ mm	_____ mm	_____ mm
		g9) Disques ventilés Ventilated disc	oui/non yes/no	oui/non yes/no	oui/non yes/no	oui/non yes/no
		g10) Surface de freinage par roue Braking surface per wheel	_____ cm²	_____ cm²	_____ cm²	_____ cm²





# FEDERATION INTERNATIONALE DU SPORT AUTOMOBILE

Homologation N°

B 262

Extension N°

22-05 ER

## FICHE D'EXTENSION A L'HOMOLOGATION OFFICIELLE FISA FORM OF EXTENSION TO THE OFFICIAL FISA HOMOLOGATION

- ES Evolution sportive du type / Sporting evolution of the type
- ET Evolution normale du type / Normal evolution of the type
- VF Variante de fourniture / Supply variant
- VO Variante option / Option variant
- ER Errata / Erratum

Homologation valable dès le \_\_\_\_\_ en groupe B  
Homologation valid as from \_\_\_\_\_ in group B

Constructeur PEUGEOT Modèle et type 205 TURBO 16  
Manufacturer Model and type

Page ou ext. Page or ext.	Art. Art.	Description Description	Avant / Front	Arrière / Rear
13-09-V0	803	<p>e) Nombre de cylindres par roue: Number of cylinders per wheel:</p> <p>e1) Alésage Bore</p> <p>f) Freins à tambours: Drum brakes:</p> <p>f1) Diamètre intérieur Interior diameter</p> <p>f2) Nombre de mâchoires par roue. Number of shoes per wheel</p> <p>f3) Surface de freinage Braking surface</p> <p>f4) Largeur des garnitures Width of the shoes</p> <p>g) Freins à disques: Disc brakes:</p> <p>g1) Nombre de sabots par roue Number of pads per wheel</p> <p>g2) Nombre d'étriers par roue Number of calipers per wheel</p>	<p>4</p> <p>38,1 et 38,1 mm</p> <p>_____ mm (± 1,5 mm)</p> <p>_____ cm<sup>2</sup></p> <p>_____ mm</p> <p>2</p> <p>1</p>	<p>4</p> <p>38,1 et 38,1 mm</p> <p>_____ mm (± 1,5 mm)</p> <p>_____ cm<sup>2</sup></p> <p>_____ mm</p> <p>2</p> <p>1</p>
		<p>g3) Matériau des étriers Caliper material</p> <p>g4) Epaisseur maximale du disque Maximum disc thickness</p> <p>g5) Diamètre extérieur du disque Exterior diameter of the disc</p> <p>g6) Diamètre extérieur de frottement des sabots Exterior diameter of the shoe's rubbing surface</p> <p>g7) Diamètre intérieur de frottement des sabots Interior diameter of the shoe's rubbing surface</p> <p>g8) Longueur hors-tout des sabots Overall length of the shoes</p> <p>g9) Disques ventilés Ventilated disc</p> <p>g10) Surface de freinage par roue Braking surface per wheel</p>	<p>Av / Front</p> <p>alu + magnésium</p> <p>_____ mm</p> <p>_____ mm (± 1 mm)</p> <p>_____ mm</p> <p>_____ mm</p> <p>_____ mm</p> <p>oui/non yes/no</p> <p>_____ cm<sup>2</sup></p>	<p>AR / Rear</p> <p>alu + magnésium</p> <p>_____ mm</p> <p>_____ mm (± 1 mm)</p> <p>_____ mm</p> <p>_____ mm</p> <p>_____ mm</p> <p>oui/non yes/no</p> <p>_____ cm<sup>2</sup></p>





# FEDERATION INTERNATIONALE DU SPORT AUTOMOBILE

Homologation N°

B 262

Extension N°

22-05 ER

FICHE D'EXTENSION A L'HOMOLOGATION OFFICIELLE FISA  
FORM OF EXTENSION TO THE OFFICIAL FISA HOMOLOGATION

- ES Evolution sportive du type / Sporting evolution of the type
- ET Evolution normale du type / Normal evolution of the type
- VF Variante de fourniture / Supply variant
- VO Variante option / Option variant
- ER Errata / Erratum

Homologation valable dès le \_\_\_\_\_ en groupe B  
Homologation valid as from \_\_\_\_\_ in group B

Constructeur PEUGEOT Modèle et type 205 TURBO 16  
Manufacturer Model and type

Page ou ext. Page or ext.	Art. Art.	Description Description	Avant / Front	Arrière / Rear
13-09-VO	803	Frein outbord et/ou inbord accolés aux ponts AV et AR		
		e) Nombre de cylindres par roue: Number of cylinders per wheel: e1) Alésage Bore	8 32 et 32 mm	8 32 et 32 mm
		f) Freins à tambours: Drum brakes: f1) Diamètre intérieur Interior diameter	mm (± 1,5 mm)	mm (± 1,5 mm)
		f2) Nombre de mâchoires par roue: Number of shoes per wheel		
		f3) Surface de freinage Braking surface	cm²	cm²
		f4) Largeur des garnitures Width of the shoes	mm	mm
		g) Freins à disques: Disc brakes: g1) Nombre de sabots par roue Number of pads per wheel	4	4
		g2) Nombre d'étriers par roue Number of callipers per wheel	2	2
		g3) Matériau des étriers Caliper material	alu + magnésium	alu + magnésium
		g4) Epaisseur maximale du disque Maximum disc thickness	mm	mm
		g5) Diamètre extérieur du disque Exterior diameter of the disc	mm (± 1 mm)	mm (± 1 mm)
		g6) Diamètre extérieur de frottement des sabots Exterior diameter of the shoe's rubbing surface	mm	mm
		g7) Diamètre intérieur de frottement des sabots Interior diameter of the shoe's rubbing surface	mm	mm
		g8) Longueur hors-tout des sabots Overall length of the shoes	mm	mm
		g9) Disques ventilés Ventilated disc	oui/non yes/no	oui/non yes/no
		g10) Surface de freinage par roue Braking surface per wheel	cm²	cm²





# FEDERATION INTERNATIONALE DU SPORT AUTOMOBILE

Homologation N°

B 262

Extension N°

22-05 ER

## FICHE D'EXTENSION A L'HOMOLOGATION OFFICIELLE FISA FORM OF EXTENSION TO THE OFFICIAL FISA HOMOLOGATION

- ES Evolution sportive du type / Sporting evolution of the type
- ET Evolution normale du type / Normal evolution of the type
- VF Variante de fourniture / Supply variant
- VO Variante option / Option variant
- ER Errata / Erratum

Homologation valable dès le \_\_\_\_\_ en groupe B  
Homologation valid as from \_\_\_\_\_ in group B

Constructeur PEUGEOT Modèle et type 205 TURBO 16  
Manufacturer Manufacturer Model and type

Page ou ext. Page or ext.	Art. Art.	Description Description	Avant / Front	Arrière / Rear
13-09-V0	803	<p>e) Nombre de cylindres par roue: Number of cylinders per wheel:</p> <p>e1) Alésage Bore</p> <p>f) Freins à tambours: Drum brakes:</p> <p>f1) Diamètre intérieur Interior diameter</p> <p>f2) Nombre de mâchoires par roue. Number of shoes per wheel</p> <p>f3) Surface de freinage Braking surface</p> <p>f4) Largeur des garnitures Width of the shoes</p> <p>g) Freins à disques: Disc brakes:</p> <p>g1) Nombre de sabots par roue Number of pads per wheel</p> <p>g2) Nombre d'étriers par roue Number of calipers per wheel</p> <p>g3) Matériau des étriers Caliper material</p> <p>g4) Epaisseur maximale du disque Maximum disc thickness</p> <p>g5) Diamètre extérieur du disque Exterior diameter of the disc</p> <p>g6) Diamètre extérieur de frottement des sabots Exterior diameter of the shoe's rubbing surface</p> <p>g7) Diamètre intérieur de frottement des sabots Interior diameter of the shoe's rubbing surface</p> <p>g8) Longueur hors-tout des sabots Overall length of the shoes</p> <p>g9) Disques ventilés Ventilated disc</p> <p>g10) Surface de freinage par roue Braking surface per wheel</p>	<p>4</p> <p>32 et 32 mm</p> <p>mm (± 1.5 mm)</p> <p>cm<sup>2</sup></p> <p>mm</p> <p>2</p> <p>1</p> <p>alu + magnésium</p> <p>mm</p> <p>mm (± 1 mm)</p> <p>mm</p> <p>mm</p> <p>mm</p> <p>oui/non yes/no</p> <p>cm<sup>2</sup></p>	<p>4</p> <p>32 et 32 mm</p> <p>mm (± 1.5 mm)</p> <p>cm<sup>2</sup></p> <p>mm</p> <p>2</p> <p>1</p> <p>alu + magnésium</p> <p>mm</p> <p>mm (± 1 mm)</p> <p>mm</p> <p>mm</p> <p>mm</p> <p>oui/non yes/no</p> <p>cm<sup>2</sup></p>





# FEDERATION INTERNATIONALE DU SPORT AUTOMOBILE

Homologation N°

B 262

Extension N°

22-05 ER

## FICHE D'EXTENSION A L'HOMOLOGATION OFFICIELLE FISA FORM OF EXTENSION TO THE OFFICIAL FISA HOMOLOGATION

- ES Evolution sportive du type / Sporting evolution of the type
- ET Evolution normale du type / Normal evolution of the type
- VF Variante de fourniture / Supply variant
- VO Variante option / Option variant
- ER Errata / Erratum

Homologation valable dès le \_\_\_\_\_ en groupe B  
Homologation valid as from \_\_\_\_\_ in group B

Constructeur PEUGEOT Modèle et type 205 TURBO 16  
Manufacturer PEUGEOT Model and type 205 TURBO 16

Page ou ext. Art. Description Frein outbord et/ou inbord accolés aux ponts AV et AR  
Page or ext. Art. Description

Page ou ext. Page or ext.	Art. Art.	Description Description	Avant / Front		Arrière / Rear	
17-12-VO	803	e) Nombre de cylindres par roue: Number of cylinders per wheel: e1) Alésage Bore f) Freins à tambours: Drum brakes: f1) Diamètre intérieur Interior diameter f2) Nombre de mâchoires par roue. Number of shoes per wheel f3) Surface de freinage Braking surface f4) Largeur des garnitures Width of the shoes g) Freins à disques: Disc brakes: g1) Nombre de sabots par roue Number of pads per wheel g2) Nombre d'étriers par roue Number of calipers per wheel	8 41,2 et 41,2 mm	8 41,2 et 41,2 mm	8 41,2 et 41,2 mm	8 41,2 et 41,2 mm
			mm (± 1,5 mm)	mm (± 1,5 mm)	cm²	cm²
			mm	mm	mm	mm
			4	4	2	2
		g3) Matériau des étriers Caliper material g4) Epaisseur maximale du disque Maximum disc thickness g5) Diamètre extérieur du disque Exterior diameter of the disc g6) Diamètre extérieur de frottement des sabots Exterior diameter of the shoe's rubbing surface g7) Diamètre intérieur de frottement des sabots Interior diameter of the shoe's rubbing surface g8) Longueur hors-tout des sabots Overall length of the shoes g9) Disques ventilés Ventilated disc g10) Surface de freinage par roue Braking surface per wheel	alu + magnésium 28,2 mm 327,5 mm (± 1 mm) 327,5 mm 220 mm 193 mm oui/non yes/no 924,5 cm²	alu + magnésium 28,2 mm 327,5 mm (± 1 mm) 327,5 mm 220 mm 133 mm oui/non yes/no 924,5 cm²		





# FEDERATION INTERNATIONALE DU SPORT AUTOMOBILE

Homologation N°

B 262

Extension N°

22-05 ER

## FICHE D'EXTENSION A L'HOMOLOGATION OFFICIELLE FISA FORM OF EXTENSION TO THE OFFICIAL FISA HOMOLOGATION

- ES Evolution sportive du type / Sporting evolution of the type
- ET Evolution normale du type / Normal evolution of the type
- VF Variante de fourniture / Supply variant
- VO Variante option / Option variant
- ER Errata / Erratum

Homologation valable dès le \_\_\_\_\_ en groupe B  
Homologation valid as from \_\_\_\_\_ in group B

Constructeur PEUGEOT Modèle et type 205 TURBO 16  
Manufacturer Manufacturer Model and type

Page ou ext. Page or ext.	Art. Art.	Description Description	Avant / Front	Arrière / Rear
17-12-VO	803	<p>Frein outbord et/ou inbord accolés aux ponts AV et AR</p> <p>e) Nombre de cylindres par roue: Number of cylinders per wheel: e1) Alésage Bore f) Freins à tambours: Drum brakes: f1) Diamètre intérieur Interior diameter f2) Nombre de mâchoires par roue. Number of shoes per wheel f3) Surface de freinage Braking surface f4) Largeur des garnitures Width of the shoes g) Freins à disques: Disc brakes: g1) Nombre de sabots par roue Number of pads per wheel g2) Nombre d'étriers par roue Number of calipers per wheel</p>	<p>4</p> <p>41,2 et 41,2 mm</p> <p>mm (± 1,5 mm)</p> <p>2</p> <p>1</p>	<p>4</p> <p>41,2 et 41,2 mm</p> <p>mm (± 1,5 mm)</p> <p>cm<sup>2</sup></p> <p>mm</p> <p>2</p> <p>1</p>
		<p>g3) Matériau des étriers Caliper material g4) Epaisseur maximale du disque Maximum disc thickness g5) Diamètre extérieur du disque Exterior diameter of the disc g6) Diamètre extérieur de frottement des sabots Exterior diameter of the shoe's rubbing surface g7) Diamètre intérieur de frottement des sabots Interior diameter of the shoe's rubbing surface g8) Longueur hors-tout des sabots Overall length of the shoes g9) Disques ventilés Ventilated disc g10) Surface de freinage par roue Braking surface per wheel</p>	<p>Alu + magnésium</p> <p>28,2 mm</p> <p>327,5 mm (± 1 mm)</p> <p>327,5 mm</p> <p>220 mm</p> <p>133 mm</p> <p>oui/non yes/no</p> <p>924,5 cm<sup>2</sup></p>	<p>Alu + magnésium</p> <p>28,2 mm</p> <p>327,5 mm (± 1 mm)</p> <p>327,5 mm</p> <p>220 mm</p> <p>133 mm</p> <p>oui/non yes/no</p> <p>924,5 cm<sup>2</sup></p>





# FEDERATION INTERNATIONALE DU SPORT AUTOMOBILE

Homologation N°

B 262

Extension N°

**22-05 ER**

FICHE D'EXTENSION A L'HOMOLOGATION OFFICIELLE FISA  
FORM OF EXTENSION TO THE OFFICIAL FISA HOMOLOGATION

- ES** Evolution sportive du type / Sporting evolution of the type
- ET** Evolution normale du type / Normal evolution of the type
- VF** Variante de fourniture / Supply variant
- VO** Variante option / Option variant
- ER** Errata / Erratum

Homologation valable dès le -1 MAI 1986 en groupe \_\_\_\_\_  
Homologation valid as from \_\_\_\_\_ in group B

Constructeur PEUGEOT Modèle et type 205 TURBO 16  
Manufacturer \_\_\_\_\_ Model and type \_\_\_\_\_

Page ou ext. Page or ext.	Art. Art.	Description Description
------------------------------	--------------	----------------------------

Freins inbord

Pont AV

Pont AR

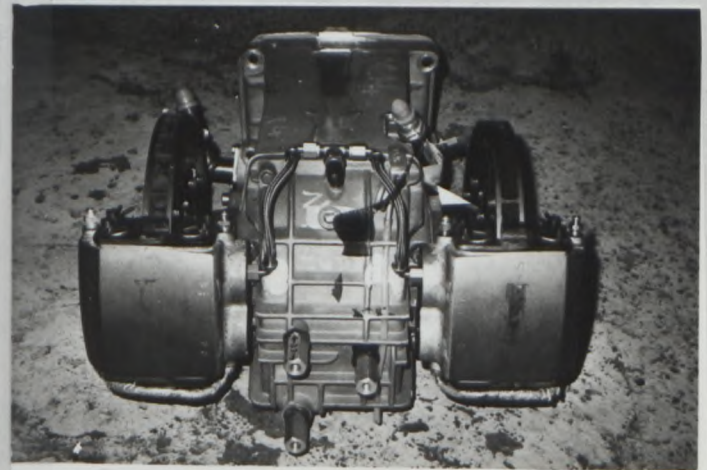
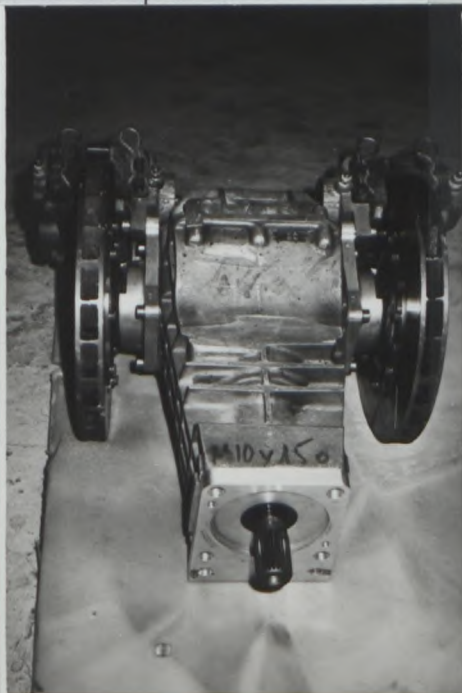

05-03-10  
08-05-10  
13-09-10  
17-12-10





# FEDERATION INTERNATIONALE DU SPORT AUTOMOBILE

Homologation N°

B 262

Extension N°

23 - 16 VO

FICHE D'EXTENSION A L'HOMOLOGATION OFFICIELLE FISA  
FORM OF EXTENSION TO THE OFFICIAL FISA HOMOLOGATION

- ES** Evolution sportive du type / Sporting evolution of the type
- ET** Evolution normale du type / Normal evolution of the type
- VF** Variante de fourniture / Supply variant
- VO** Variante option / Option variant
- ER** Errata / Erratum

Homologation valable dès le - 1 JUL. 1986 en groupe B  
Homologation valid as from \_\_\_\_\_ in group \_\_\_\_\_

Constructeur PEUGEOT Modèle et type 205 TURBO 16  
Manufacturer \_\_\_\_\_ Model and type \_\_\_\_\_

Page ou ext. Page or ext.	Art. Art.	Description Description	
	605	Différentiel central - rapport : 1,611 - Nombre de dents : 29/18	
	707	Pivot renforcé	Photo 1
	707	Bras de suspension renforcé arrière supérieur matériau : acier	Photo 2



*Paul H. Humez*



# FEDERATION INTERNATIONALE DU SPORT AUTOMOBILE

Homologation N°

B 262

Extension N°

23 - 16 VO

## FICHE D'EXTENSION A L'HOMOLOGATION OFFICIELLE FISA FORM OF EXTENSION TO THE OFFICIAL FISA HOMOLOGATION

- ES** Evolution sportive du type / Sporting evolution of the type
- ET** Evolution normale du type / Normal evolution of the type
- VF** Variante de fourniture / Supply variant
- VO** Variante option / Option variant
- ER** Errata / Erratum

Homologation valable dès le \_\_\_\_\_ en groupe **B**  
Homologation valid as from \_\_\_\_\_ in group

Constructeur **PEUGEOT** Modèle et type **205 TURBO 16**  
Manufacturer \_\_\_\_\_ Model and type \_\_\_\_\_

Page ou ext. Page or ext.	Art. Art.	Description Description	.Photo 3 - 4	Photo 3 - 4																																		
	803	<p>e) Nombre de cylindres par roue: Number of cylinders per wheel:</p> <p>e1) Alésage Bore</p> <p>f) Freins à tambours: Drum brakes:</p> <p>f1) Diamètre intérieur Interior diameter</p> <p>f2) Nombre de mâchoires par roue. Number of shoes per wheel</p> <p>f3) Surface de freinage Braking surface</p> <p>f4) Largeur des garnitures Width of the shoes</p> <p>g) Freins à disques: Disc brakes:</p> <p>g1) Nombres de sabots par roue Number of pads per wheel</p> <p>g2) Nombre d'étriers par roue Number of callipers per wheel</p> <p>g3) Matériau des étriers Caliper material</p> <p>g4) Epaisseur maximale du disque Maximum disc thickness</p> <p>g5) Diamètre extérieur du disque Exterior diameter of the disc</p> <p>g6) Diamètre extérieur de frottement des sabots Exterior diameter of the shoe's rubbing surface</p> <p>g7) Diamètre intérieur de frottement des sabots Interior diameter of the shoe's rubbing surface</p> <p>g8) Longueur hors-tout des sabots Overall length of the shoes</p> <p>g9) Disques ventilés Ventilated disc</p> <p>g10) Surface de freinage par roue Braking surface per wheel</p>	<table border="1"> <thead> <tr> <th>Avant / Front</th> <th>Arrière / Rear</th> </tr> </thead> <tbody> <tr> <td>4</td> <td>4</td> </tr> <tr> <td>42 et 38 mm</td> <td>42 et 38 mm</td> </tr> <tr> <td>_____ mm (± 1.5 mm)</td> <td>_____ mm (± 1.5 mm)</td> </tr> <tr> <td>_____ cm<sup>2</sup></td> <td>_____ cm<sup>2</sup></td> </tr> <tr> <td>_____ mm</td> <td>_____ mm</td> </tr> <tr> <td>2</td> <td>2</td> </tr> <tr> <td>1</td> <td>1</td> </tr> </tbody> </table> <table border="1"> <thead> <tr> <th>AV / Front</th> <th>AR / Rear</th> </tr> </thead> <tbody> <tr> <td>aluminium</td> <td>aluminium</td> </tr> <tr> <td>28,2 mm</td> <td>28,2 mm</td> </tr> <tr> <td>327,5 mm (± 1 mm)</td> <td>327,5 mm (± 1 mm)</td> </tr> <tr> <td>327,5 mm</td> <td>327,5 mm</td> </tr> <tr> <td>220 mm</td> <td>220 mm</td> </tr> <tr> <td>133 mm</td> <td>133 mm</td> </tr> <tr> <td>Oui/yes</td> <td>oui/yes</td> </tr> <tr> <td>924,5 cm<sup>2</sup></td> <td>924,5 cm<sup>2</sup></td> </tr> </tbody> </table>	Avant / Front	Arrière / Rear	4	4	42 et 38 mm	42 et 38 mm	_____ mm (± 1.5 mm)	_____ mm (± 1.5 mm)	_____ cm <sup>2</sup>	_____ cm <sup>2</sup>	_____ mm	_____ mm	2	2	1	1	AV / Front	AR / Rear	aluminium	aluminium	28,2 mm	28,2 mm	327,5 mm (± 1 mm)	327,5 mm (± 1 mm)	327,5 mm	327,5 mm	220 mm	220 mm	133 mm	133 mm	Oui/yes	oui/yes	924,5 cm <sup>2</sup>	924,5 cm <sup>2</sup>	
Avant / Front	Arrière / Rear																																					
4	4																																					
42 et 38 mm	42 et 38 mm																																					
_____ mm (± 1.5 mm)	_____ mm (± 1.5 mm)																																					
_____ cm <sup>2</sup>	_____ cm <sup>2</sup>																																					
_____ mm	_____ mm																																					
2	2																																					
1	1																																					
AV / Front	AR / Rear																																					
aluminium	aluminium																																					
28,2 mm	28,2 mm																																					
327,5 mm (± 1 mm)	327,5 mm (± 1 mm)																																					
327,5 mm	327,5 mm																																					
220 mm	220 mm																																					
133 mm	133 mm																																					
Oui/yes	oui/yes																																					
924,5 cm <sup>2</sup>	924,5 cm <sup>2</sup>																																					



Marque PEUGEOT  
Make

Modèle 205 TURBO 16  
Model

N° Homol. B 262

PHOTOS / PHOTOS

N° Ext. 23 - 16 V0

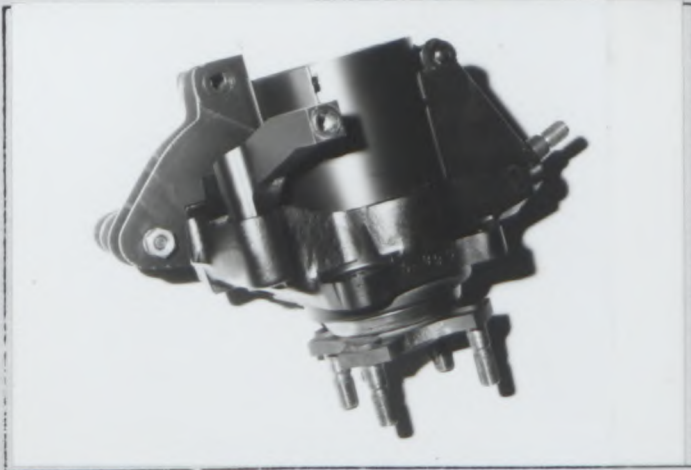

Photo 1



Photo 2

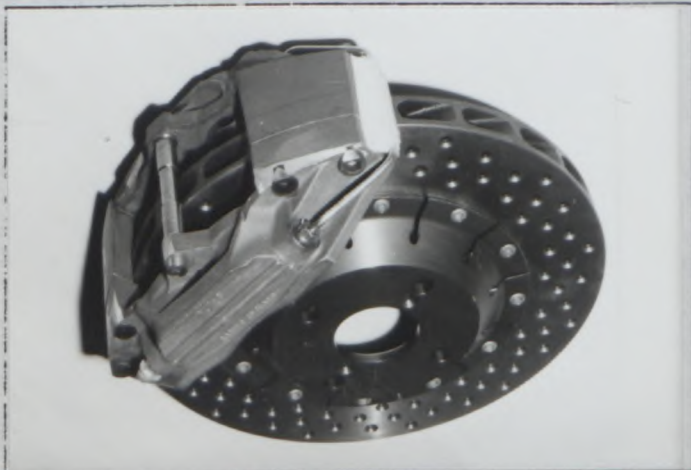

Photo 3

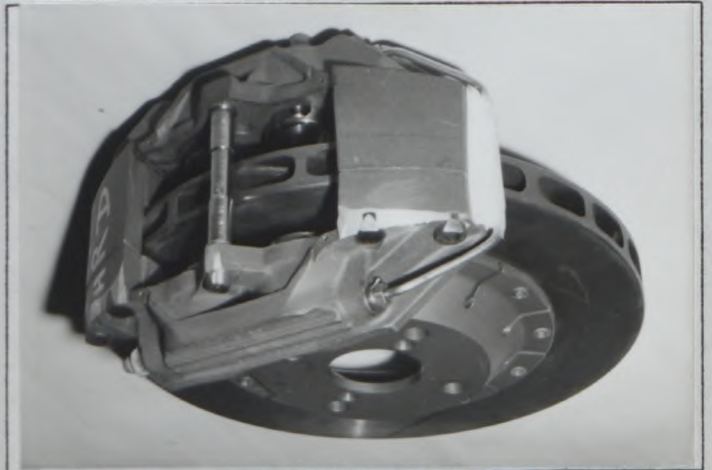
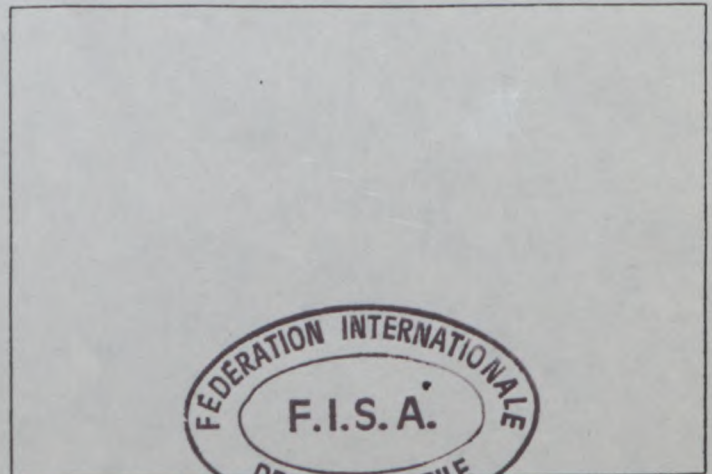
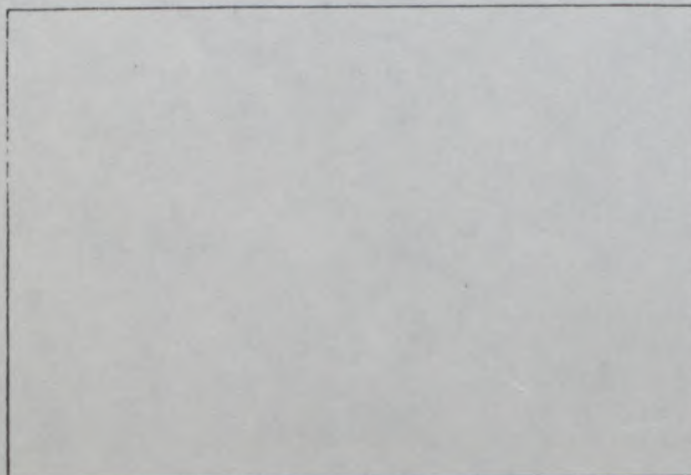

Photo 4





# FEDERATION INTERNATIONALE DU SPORT AUTOMOBILE

Homologation N°

B 262

Extension N°

24 / 17 VO

FICHE D'EXTENSION A L'HOMOLOGATION OFFICIELLE FISA  
FORM OF EXTENSION TO THE OFFICIAL FISA HOMOLOGATION

ET Evolution normale du type: dès le numéro de châssis  
Normal evolution of the type: as from chassis number \_\_\_\_\_

VF Variante de fourniture / Supply variant

VO Variante option / Option variant

ER Errata / Erratum

Homologation valable dès le - 1 OCT. 1986 en groupe  
Homologation valid as from \_\_\_\_\_ in group B

Constructeur PEUGEOT Modèle et type 205 TURBO 16  
Manufacturer \_\_\_\_\_ Model and type \_\_\_\_\_

Page ou ext. Page or ext.	Art. Art.	Description Frein Outboard AV et AR Description	Photo 1	Photo 1																																
	803	e) Nombre de cylindres par roue. Number of cylinders per wheel: e1) Alésage Bore f) Freins à tambours: Drum brakes: (1) Diamètre intérieur Interior diameter (2) Nombre de mâchoires par roue. Number of shoes per wheel (3) Surface de freinage Braking surface (4) Largeur des garnitures Width of the shoes g) Freins à disques: Disc brakes: g1) Nombres de sabots par roue Number of pads per wheel g2) Nombre d'étriers par roue Number of calipers per wheel g3) Matériau des étriers Caliper material g4) Epaisseur maximale du disque Maximum disc thickness g5) Diamètre extérieur du disque Exterior diameter of the disc g6) Diamètre extérieur de frottement des sabots Exterior diameter of the shoe's rubbing surface g7) Diamètre intérieur de frottement des sabots Interior diameter of the shoe's rubbing surface g8) Longueur hors-tout des sabots Overall length of the shoes g9) Disques ventilés Vented disc g10) Surface de freinage par roue Braking surface per wheel	<table border="1"> <thead> <tr> <th>Avant / Front</th> <th>Arrière / Rear</th> </tr> </thead> <tbody> <tr> <td>4</td> <td>4</td> </tr> <tr> <td>41.3 et 38.1 mm</td> <td>41.3 et 38.1 mm</td> </tr> <tr> <td>_____ mm (± 1.5 mm)</td> <td>_____ mm (± 1.5 mm)</td> </tr> <tr> <td>_____ cm'</td> <td>_____ cm'</td> </tr> <tr> <td>_____ mm</td> <td>_____ mm</td> </tr> <tr> <td>2</td> <td>2</td> </tr> <tr> <td>1</td> <td>1</td> </tr> <tr> <td>Aluminium</td> <td>Aluminium</td> </tr> <tr> <td>28.02 mm</td> <td>28.02 mm</td> </tr> <tr> <td>300 mm (± 1 mm)</td> <td>300 mm (± 1 mm)</td> </tr> <tr> <td>300 mm</td> <td>300 mm</td> </tr> <tr> <td>194 mm</td> <td>194 mm</td> </tr> <tr> <td>131.75 mm</td> <td>131.75 mm</td> </tr> <tr> <td>oui/new yes/no-</td> <td>oui/new yes/no-</td> </tr> <tr> <td>822.5 cm'</td> <td>822.5 cm'</td> </tr> </tbody> </table>	Avant / Front	Arrière / Rear	4	4	41.3 et 38.1 mm	41.3 et 38.1 mm	_____ mm (± 1.5 mm)	_____ mm (± 1.5 mm)	_____ cm'	_____ cm'	_____ mm	_____ mm	2	2	1	1	Aluminium	Aluminium	28.02 mm	28.02 mm	300 mm (± 1 mm)	300 mm (± 1 mm)	300 mm	300 mm	194 mm	194 mm	131.75 mm	131.75 mm	oui/new yes/no-	oui/new yes/no-	822.5 cm'	822.5 cm'	
Avant / Front	Arrière / Rear																																			
4	4																																			
41.3 et 38.1 mm	41.3 et 38.1 mm																																			
_____ mm (± 1.5 mm)	_____ mm (± 1.5 mm)																																			
_____ cm'	_____ cm'																																			
_____ mm	_____ mm																																			
2	2																																			
1	1																																			
Aluminium	Aluminium																																			
28.02 mm	28.02 mm																																			
300 mm (± 1 mm)	300 mm (± 1 mm)																																			
300 mm	300 mm																																			
194 mm	194 mm																																			
131.75 mm	131.75 mm																																			
oui/new yes/no-	oui/new yes/no-																																			
822.5 cm'	822.5 cm'																																			



Marque  
Make

Peugeot

Modèle  
Model

205 Turbo 16

N° Homol.

B262

PHOTOS / PHOTOS

N° Ext. **24 / 17 V0**

Photo 1

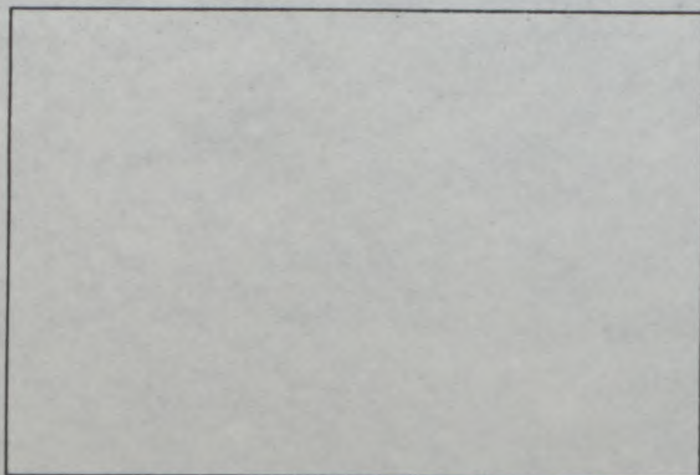
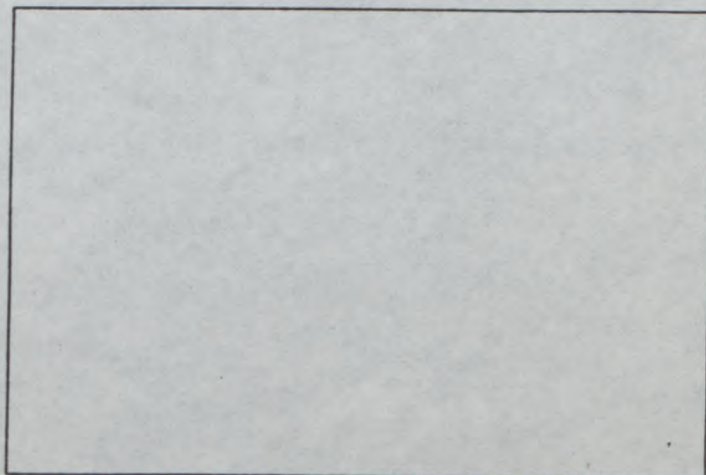
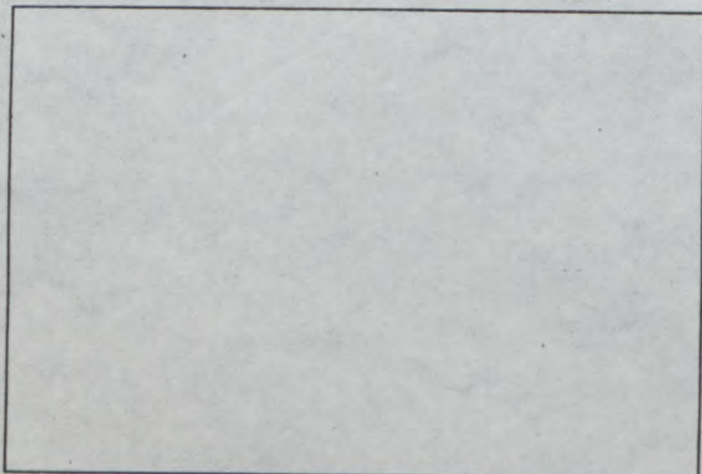
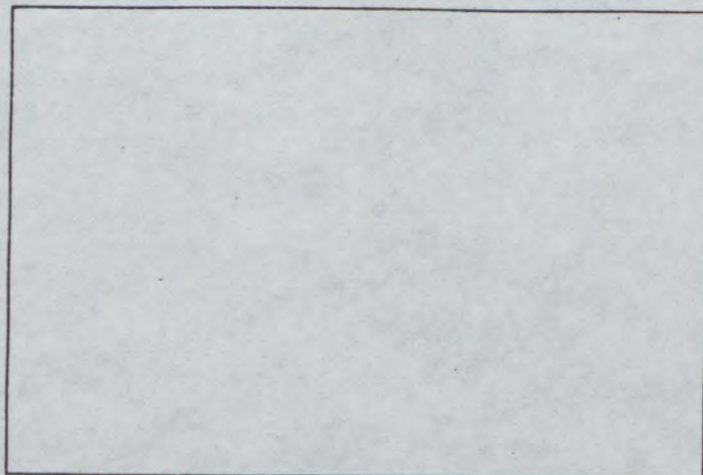



# FEDERATION INTERNATIONALE DU SPORT AUTOMOBILE

Homologation N°

B 262

Extension N°

25 / 18 VO

FICHE D'EXTENSION A L'HOMOLOGATION OFFICIELLE FISA  
FORM OF EXTENSION TO THE OFFICIAL FISA HOMOLOGATION

- ES Evolution sportive du type / Sporting evolution of the type
- ET Evolution normale du type / Normal evolution of the type
- VF Variante de fourniture / Supply variant
- VO Variante option / Option variant
- ER Errata / Erratum

Homologation valable dès le -1 OCT. 1986 en groupe B  
Homologation valid as from \_\_\_\_\_ in group \_\_\_\_\_

Constructeur PEUGEOT Modèle et type 205 TURBO 16  
Manufacturer \_\_\_\_\_ Model and type \_\_\_\_\_

Page ou ext. Page or ext.	Art. Art.	Description Description	<i>Photo 1</i> Avant / Front	<i>Photo 1</i> Arrière / Rear
		e) Nombre de cylindres par roue: Number of cylinders per wheel: e1) Alésage Bore	4 42 et 38 mm	4 42 et 38 mm
		f) Freins à tambours: Drum brakes: f1) Diamètre intérieur Interior diameter	_____ mm (± 1.5 mm)	_____ mm (± 1.5 mm)
		f2) Nombre de mâchoires par roue Number of shoes per wheel	_____	_____
		f3) Surface de freinage Braking surface	_____ cm <sup>2</sup>	_____ cm <sup>2</sup>
		f4) Largeur des garnitures Width of the shoes	_____ mm	_____ mm
		g) Freins à disques: Disc brakes: g1) Nombre de sabots par roue Number of pads per wheel:	2	2
		g2) Nombre d'étriers par roue Number of calipers per wheel:	1	1
		g3) Matériau des étriers Caliper material	alu	alu
		g4) Epaisseur maximale du disque Maximum disc thickness	28,1 mm	28,1 mm
		g5) Diamètre extérieur du disque Exterior diameter of the disc	315 mm (± 1 mm)	315 mm (± 1 mm)
		g6) Diamètre extérieur de frottement des sabots Exterior diameter of the shoe's rubbing surface	315 mm	315 mm
		g7) Diamètre intérieur de frottement des sabots Interior diameter of the shoe's rubbing surface	220 mm	220 mm
		g8) Longueur hors-tout des sabots Overall length of the shoes	133 mm	133 mm
		g9) Disques ventilés Ventilated disc	Oui/yes	Oui/yes
		g10) Surface de freinage par roue Braking surface per wheel	798,36 cm <sup>2</sup>	798,36 cm <sup>2</sup>



*Signature*

Marque PEUGEOT  
Make

Modèle 205 TURBO 16  
Model

N° Homol. B 262

PHOTOS / PHOTOS

N° Ext. 25 / 18 V0

Photo 1

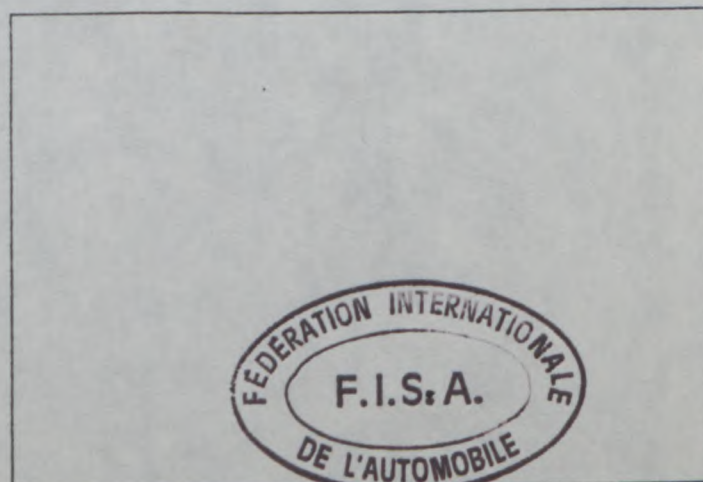
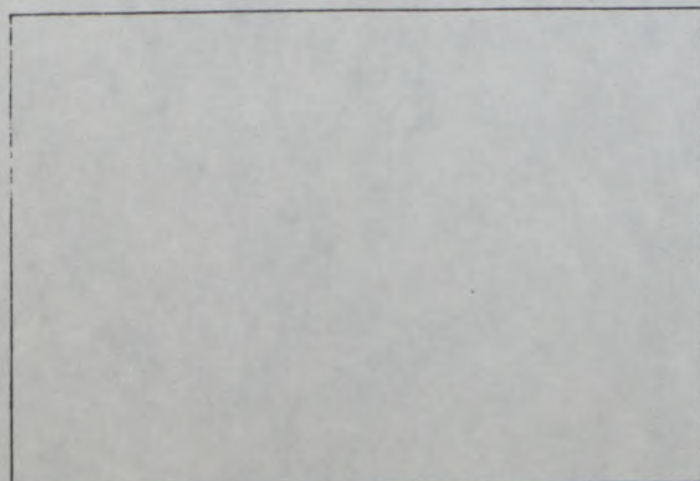
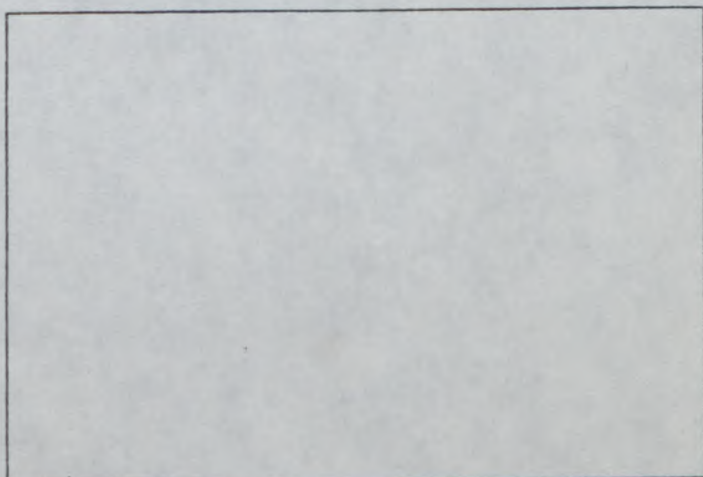
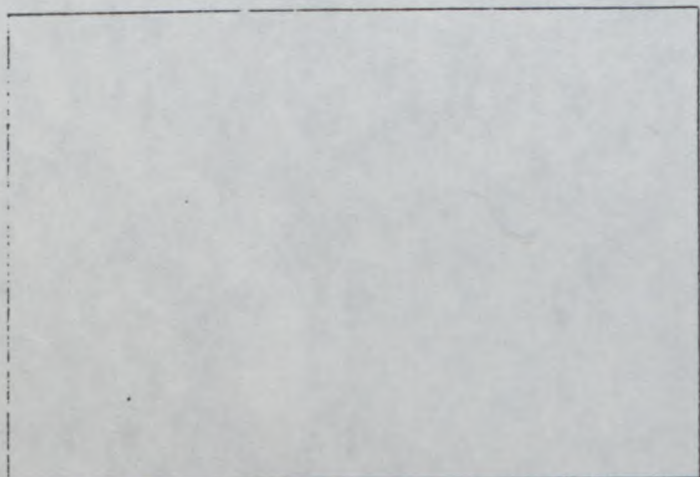
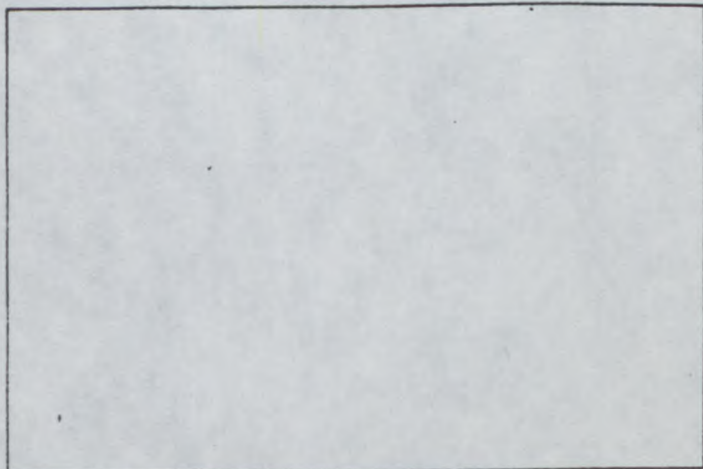
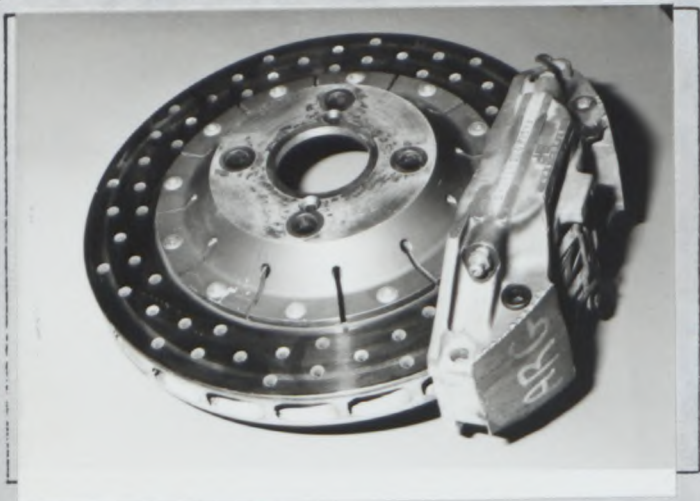



# FEDERATION INTERNATIONALE DU SPORT AUTOMOBILE

Homologation N°

B - 262

Extension N°

26 / 06 ER

FICHE D'EXTENSION A L'HOMOLOGATION OFFICIELLE FISA  
FORM OF EXTENSION TO THE OFFICIAL FISA HOMOLOGATION

- ES** Evolution sportive du type / Sporting evolution of the type
- ET** Evolution normale du type / Normal evolution of the type
- VF** Variante de fourniture / Supply variant
- VO** Variante option / Option variant
- ER** Errata / Erratum

Homologation valable dès le \_\_\_\_\_ en groupe \_\_\_\_\_  
Homologation valid as from 1er Janvier 1988 in group B

Constructeur \_\_\_\_\_ Modèle et type \_\_\_\_\_  
Manufacturer PEUGEOT Model and type 205 Turbo 16

Page ou ext. Page or ext.	Art. Art.	Description Description
------------------------------	--------------	----------------------------

Suite au changement du coefficient de suralimentation  
porté de (1.4) à (1.7) au 1er Janvier 1988 :

Articles 103 et 307b :            1774.6 x 1.7 = 3016.82

Article 307c :                    1800.43 x 1.7 = 3060.73

Article 315 :                      83.6



*[Signature]*



FEDERATION INTERNATIONALE DE L'AUTOMOBILE

CERTIFICAT DE PRODUCTION  
PRODUCTION CERTIFICATE

B-262

02/01 ET

Constructeur PEUGEOT  
Manufacturer

Date 30 mars 1984

Modèle de voiture 205 TURBO 16  
Car Model

Type ou désignation commerciale /

Type or commercial designation

205 TURBO 16

N° d'homologation  
homologation n°

Période de production de 15/01/84  
Production period from

Nature de l'extension

EVOLUTION

Nature of the extension

à/to 30/03/84

Mois / Année  
Month / Year

Nombre  
Number

Je soussigné certifie que la production mentionnée ci-dessus s'entend pour des voitures entièrement terminées, identiques et conformes à la fiche d'homologation présentée pour ce modèle.

I hereby certify that the production mentioned here-above concerns cars which are entirely completed, identical and in conformity with the recognition form submitted for the said model.

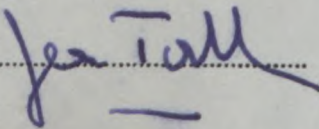
Signature 

Fonction DIRECTEUR DE PEUGEOT TALBOT SPORT  
Position

- 1
- 2
- 3
- 4
- 5
- 6
- 7
- 8
- 9
- 10
- 11
- 12

TOTAL

20

Observations  
Remarks