

# Borg & Warner T10

Pre-66 basics

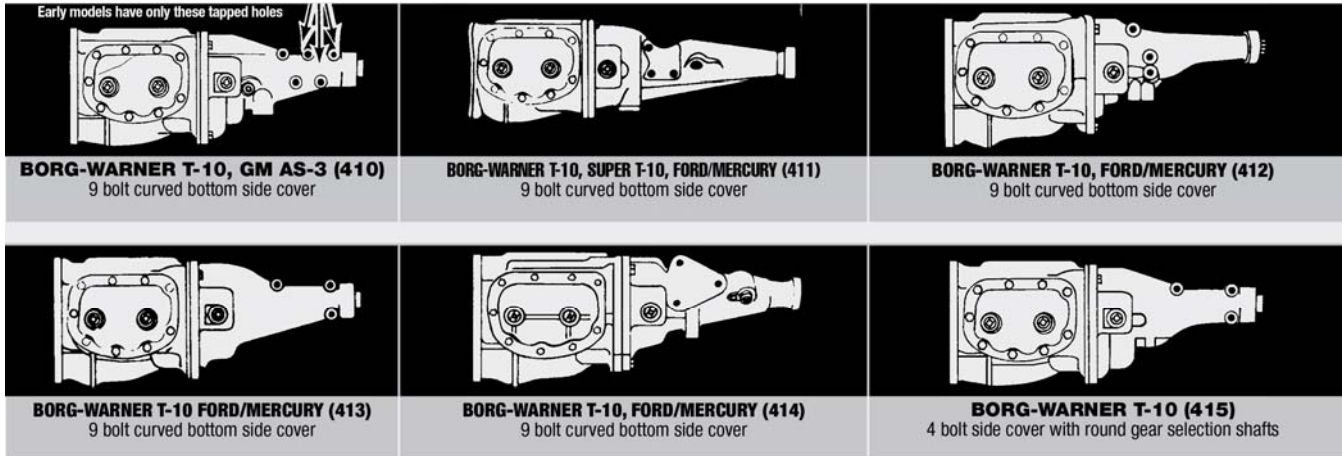

8 Bolts at bell-housing and 9 bolt curved bottom side cover is considered as standard specification

Cast iron main case and tail shaft housing as well.

---

## Shelby Cobra 289

4 bolts at bell-housing and after main case to tail shaft housing is specific to **T10B-1**.

Aluminium main case and tail shaft housing.



---

## Shelby GT350

8 bolts at bell-housing and after main case to tail shaft housing is specific to **T10M-1**.

Aluminium main case and tail shaft housing.



## GM and Ford equipped cars.

In any case and for Pre-66 applications, the following parts should not be accepted.  
For later period cars, the use of the casing below must be demonstrated.

