



FEDERATION INTERNATIONALE DE L'AUTOMOBILE

FORD - MUSTANG 428 HARDTOP

1/69

5253

MARQUE ET MODELE

VALIDITE HOMOLOGATION

FICHE NR.

A / +2030

GROUPE / CLASSE

| EXTENSIONS | DEBUT VALIDITE | DESCRIPTION | NOTES |
|------------|----------------|-------------|-------|
| | | | |
| | | | |
| | | | |
| | | | |
| | | | |
| | | | |
| | | | |
| | | | |
| | | | |
| | | | |
| | | | |
| | | | |
| | | | |
| | | | |
| | | | |
| | | | |
| | | | |
| | | | |
| | | | |
| | | | |
| | | | |
| | | | |
| | | | |
| | | | |
| | | | |
| | | | |
| | | | |
| | | | |

Autres homologations du modèle

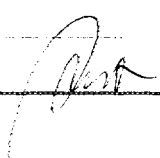
Vérifiée le 26/10/95 par  visée ce jour le _____ par _____

Telephone: (203) 348-6233



Cable Address: "ACCUSFIA" Stamford, Conn.

AUTOMOBILE COMPETITION COMMITTEE FOR THE UNITED STATES, FIA, INC.

433 MAIN STREET, STAMFORD, CONN. 06901

Federation Internationale de l'Automobile



STANDARD CERTIFICATE OF PRODUCTION

In accordance with Appendix "J" of the International Sporting Code

Name of Manufacturer Ford Motor Company

Make of Car Ford Model 1969 Mustang 428 Hardtop

We certify that 5,000 cars identical with the basic specification, as well as 5,000 cars as modified by the listed optional equipment (when required by Appendix "J"), were completed as of October 18, 1968.

Cars conforming to this specification may be identified by chassis numbers 9 01 100001, and engine numbers none.

Signed:

J. F. Passino
J. F. Passino, Manager
Special Vehicles Activity

F. A. Hernandez
F. A. Hernandez
Stock Vehicles Department
Special Vehicles Activity

Certified:

John K. O'Leary
ACCUS, FIA, Inc.



MAKE Ford

MODEL '69 Mustang 428 HT

FIA REC # 5253

M
428
H.T.
G1



Telephone: (203) 348-6233

Cable Address: "ACCUSFIA" Stamford, Conn.

AUTOMOBILE COMPETITION COMMITTEE FOR THE UNITED STATES, FIA, INC.

433 MAIN STREET, STAMFORD, CONN. 06901

Federation Internationale de l'Automobile
FORM OF RECOGNITION

In accordance with Appendix "J" of the International Sporting Code

I N D E X

| <u>ITEM</u> | <u>NUMBERS</u> | <u>PAGES</u> |
|-------------------------------|----------------|--------------|
| Basic Data & Photo | | 1 |
| Photos | | 2-3 |
| Sketches | | 4 |
| Capacities & Dimensions | 1-9 | 5 |
| Chassis & Bodywork | 20-32 | 6 |
| Accessories & Upholstery | 38-45 | 6 |
| Wheels | 50-54 | 6 |
| Steering | 70-82 | 6-7 |
| Brakes | 90-105 | 7 |
| Engine | 130-203 | 8-10 |
| Carburetion | 210-216 | 10 |
| Injection | 220-225 | 10 |
| Engine Accessories | 230-241 | 11 |
| Engine & Car Performance | 250-253 | 11 |
| Drive Train | 260-293 | 11-12 |
| Optional Equipment | | 13-14 |
| Variants & Evolutions, if any | | |

CONVERSION TABLE:

| | | |
|-----------------------------|------------------------|----------------|
| 1 inch / pouce | 2.54 cm | |
| 1 foot / pied | 30.479 cm | |
| 1 square inch / pouce carre | 6.452 cm ² | |
| 1 cubic inch / pouce cube | 16.387 cm ³ | |
| 1 pound (lb.) / livre | 453.593 gr | |
| 1 pint (U.S.) | .473 ltrs | .833 pt. Imp. |
| 1 quart (U.S.) | .946 ltrs | .833 qt. Imp. |
| 1 gallon (U.S.) | 3.785 ltrs | .833 gal. Imp. |
| 1 pint (Imp.) | .568 ltrs | 1.20 pt. U.S. |
| 1 quart (Imp.) | 1.136 ltrs | 1.20 qt. U.S. |
| 1 gallon (Imp.) | 4.546 ltrs | 1.20 gal. U.S. |



AUTOMOBILE COMPETITION COMMITTEE
FOR THE UNITED STATES, F.I.A., INC.

433 MAIN ST.
STAMFORD, CONN. 06901
(203) 348-6233

M
428
5253 H.P.
GI
STW

Federation Internationale de l'Automobile
FORM OF RECOGNITION

In accordance with Appendix "J" of the International Sporting Code

Cylinder capacity 7003.2 cm³ 427.36 in³

Manufacturer Ford Model 1969 Mustang 428 Hardtop

Serial # Chassis 9_01_100001 Manufacturer Ford

Serial # Engine None Manufacturer Ford

Recognition valid from 1. 1. 1969 List _____

The manufacturing of the model described in this recognition form was started on August 19 and the minimum production of 10,000 identical cars, in accordance with the specifications of this form, was reached on October 18, 1968.

- (*) need not be answered for Group II and III cars.
- (**) only need to be answered for Group IV cars.

A 3/4 Front View Car **

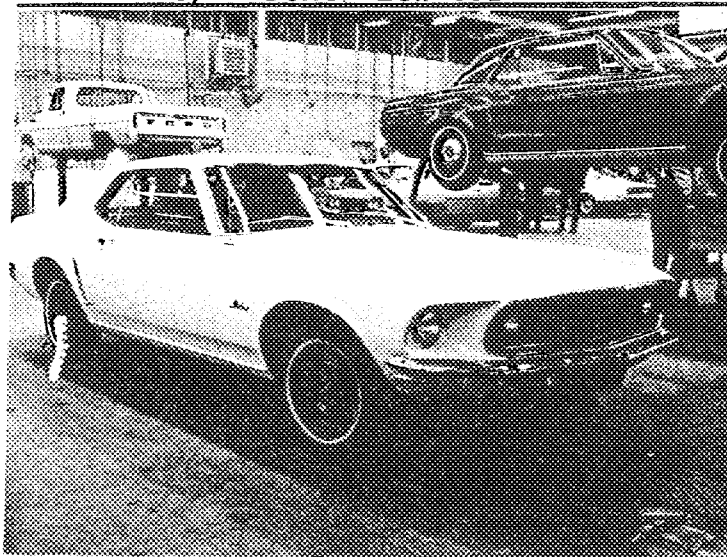

The vehicle described in this form has been subject to the following amendments:

Variants

on 19 rec # list

on 19 rec # list

on 19 rec # list

Normal evolution of the type

on 19 rec # list

on 19 rec # list

on 19 rec # list

Stamp/Signature of
National Sporting Authority

John W. Oliver

Stamp/Signature
F.I.A.

B 3/4 rear car (**)

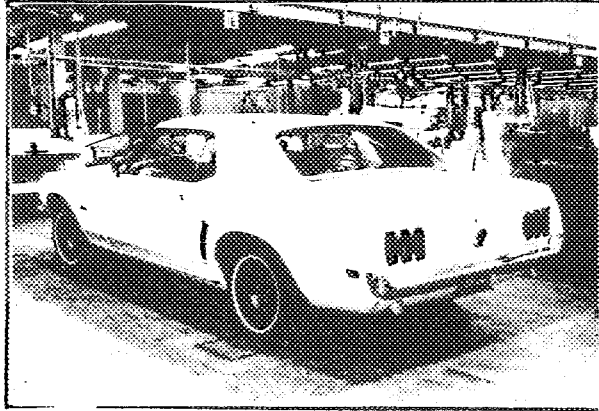

C interior-car (**)

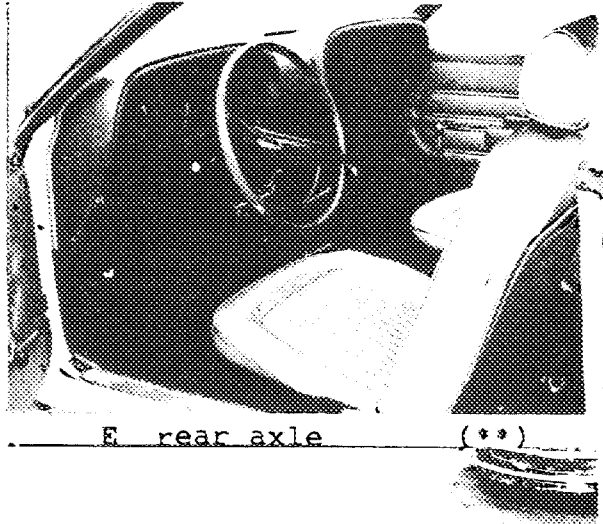

front axle (**)

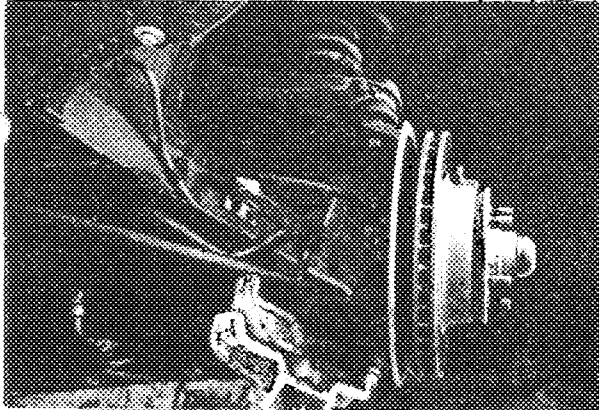

E rear axle (**)

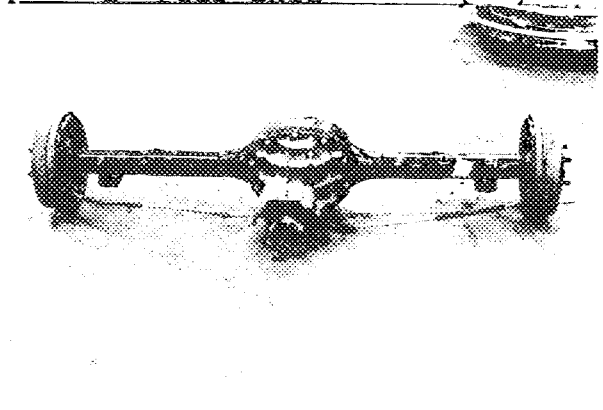

F brake, front (**)

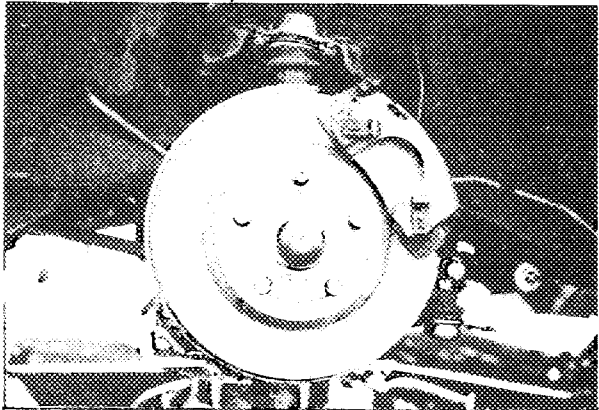

G brake, rear (**)

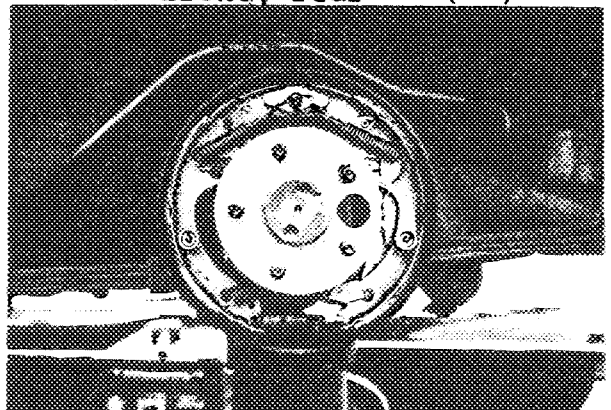

H gear box (**)

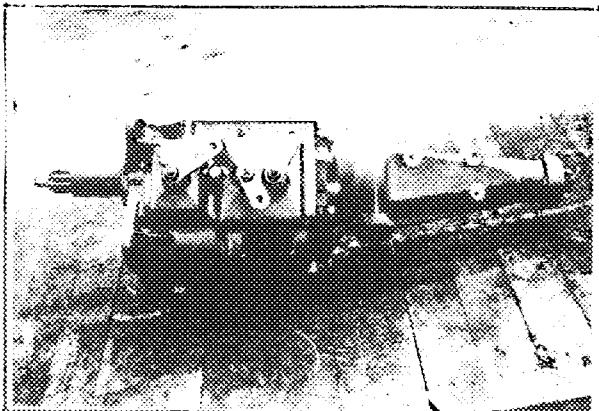

I exhaust system (*)

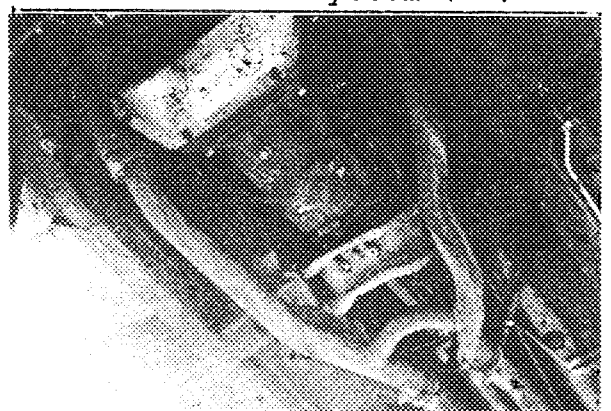

STAMP

STAMP

FIA REC #5253

MAKE Ford

MODEL '69 Mustang 428 HT FIA REC # 5253

M
428
H.T.
GI

J ENGINE RIGHT (**)

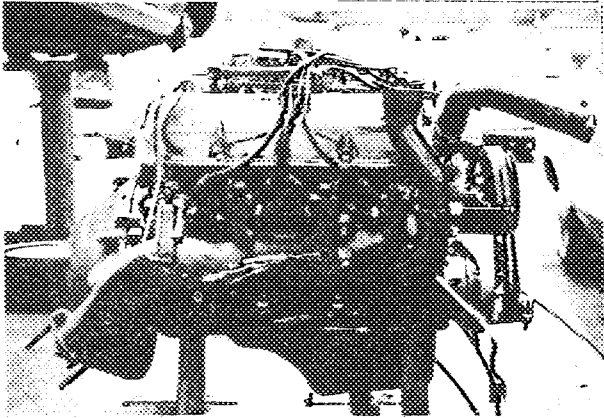

K ENGINE LEFT (**)

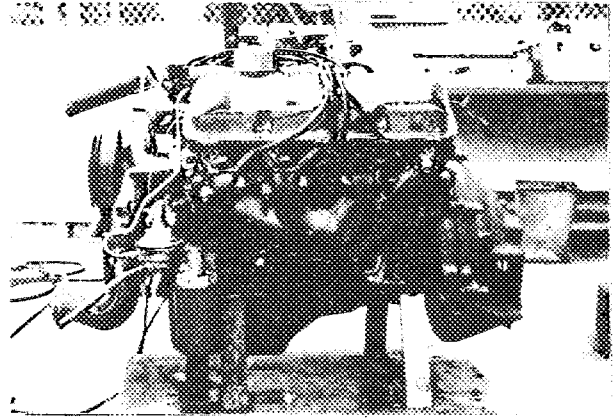

L COMBUSTION CHAMBER

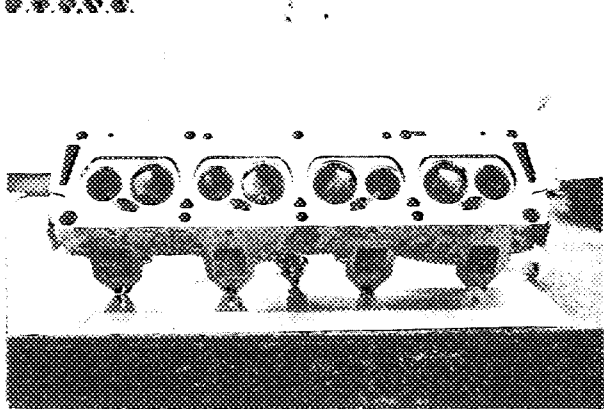

M PISTON TOP (*)

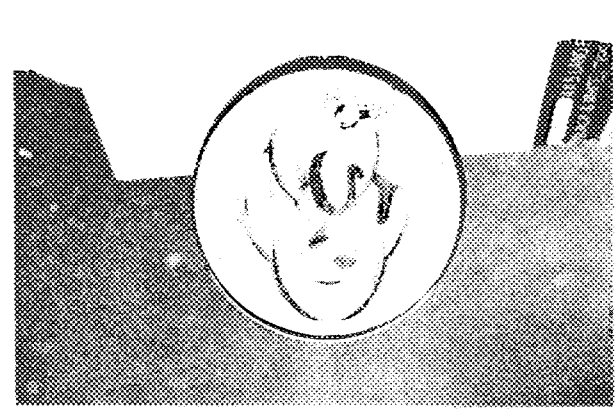

N CARBURETOR (*)

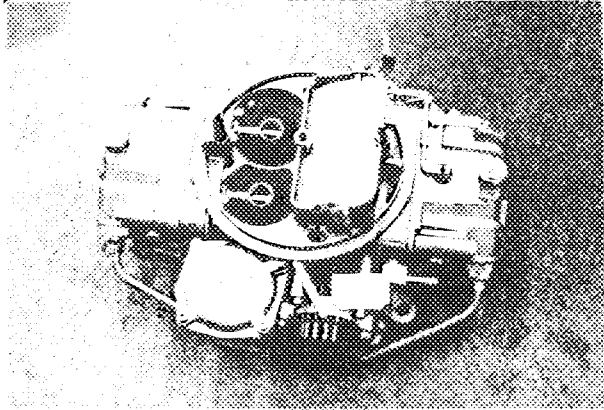

O ENGINE IN PLACE (**)

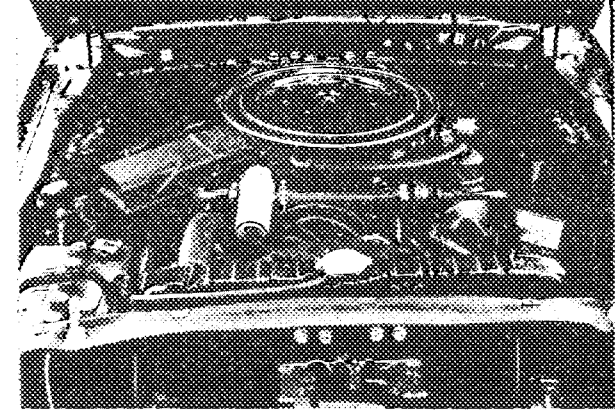

P MANIFOLD INLET

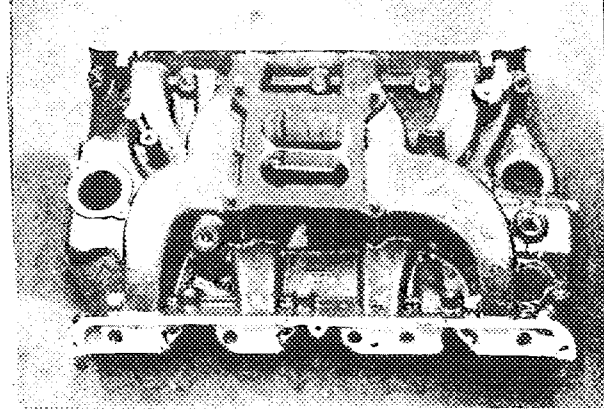

Q MANIFOLD EXHAUST



Strip out: ALL SKETCHES MUST INDICATE ACTUAL DIMENSIONS AND MANUFACTURER'S TOLERANCES. STAMP STAMP

MAKE Ford MODEL '69 Mustang 428 HTFIA REC # 5253

ALL SKETCHES MUST INDICATE ACTUAL DIMENSIONS AND MANUFACTURER'S TOLERANCES. $\pm .04$ in. or ± 1.0 mm

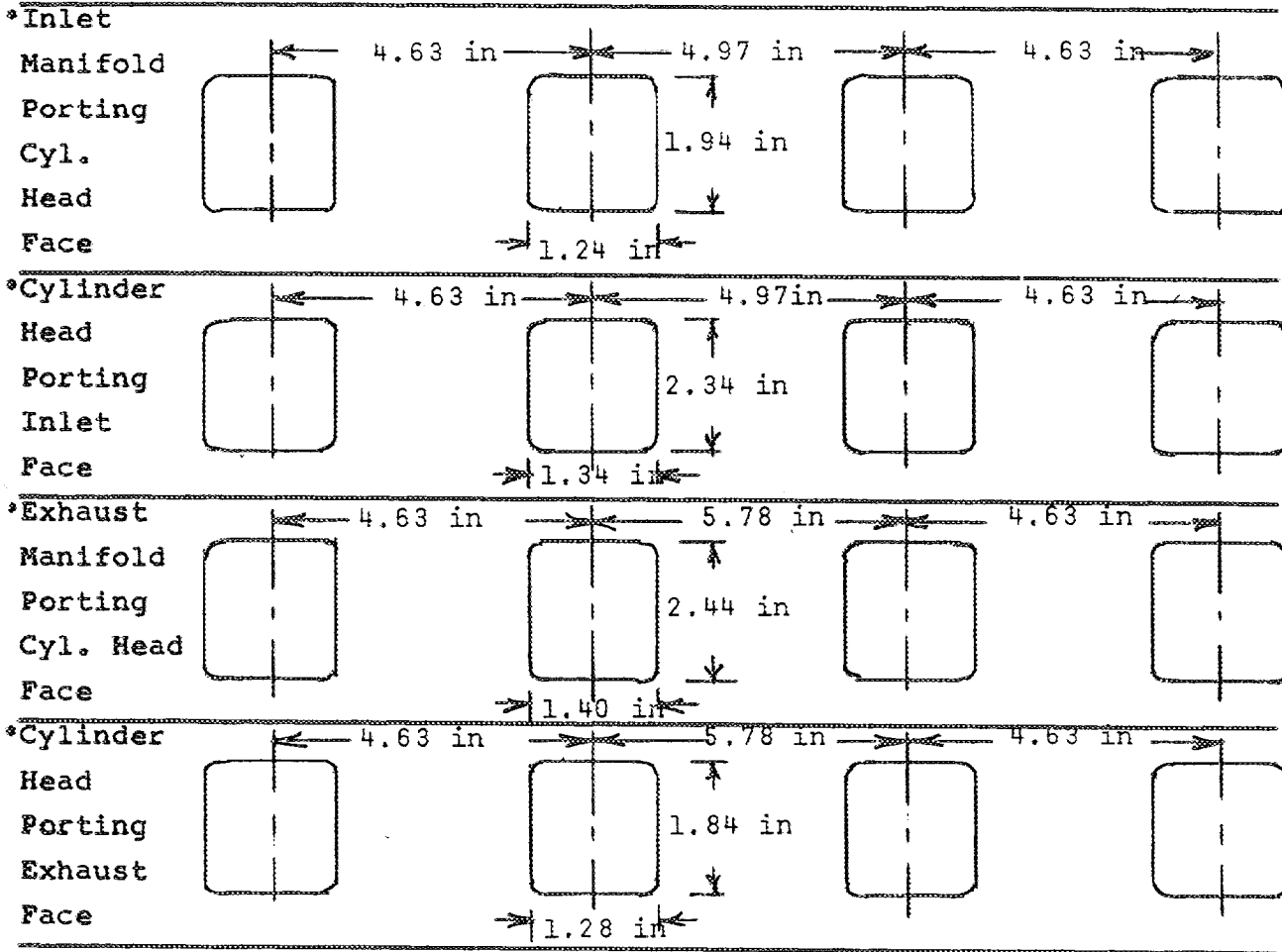

CAM

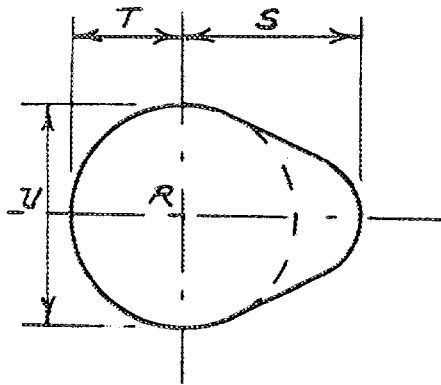

| <u>Inlet cam</u> | | |
|------------------|----------|----------|
| S= | 26.31 mm | 1.036 in |
| T= | 20.24 mm | .797 in |
| U= | 37.95 mm | 1.494 in |

| <u>Exhaust cam</u> | | |
|--------------------|----------|----------|
| S= | 26.31 mm | 1.036 in |
| T= | 20.24 mm | .797 in |
| U= | 37.95 mm | 1.494 in |

STAMP

STAMP

IMPORTANT: Questions 1 through 9 must be answered in two measuring systems, one of which must be the metric system. See conversion table at index.

CAPACITIES & DIMENSIONS

- (**) 1. Wheelbase 2743.2 mm 108.0 in
- (**) 2. Front track 1498.6 mm 59.0 in + at 0° camber
- (**) 3. Rear track 1485.9 mm 58.5 in + 0" toe-in
+ Differences in track resulting from use of optional wheel and rim sizes must be stipulated on recognition application forms. *See Note Below.

Dimensional relationship between track (front and/or rear) and ground clearance resulting from use of optional wheel sizes shall also be stipulated and a sketch illustrating suspension reference points shall be shown below to establish the "reference chassis height." The reference chassis height dimension is to be used only when checking track and shall not affect eligibility of car in any manner.

Sketch, Ground Clearance: Dimensional Suspension & Chassis Reference Points"

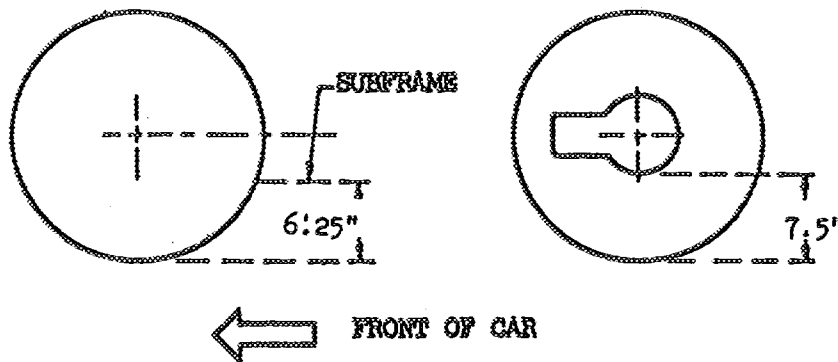

* Note: Geometry changes in front suspension will alter track.

- 4. Overall length of car 477.0 cm 187.4 in
- 5. Overall width of car 181.0 cm 71.3 in
- 6. Overall height of car 130.0 cm 51.3 in
- 7. Capacity of fuel tank (reserve included) 75.70 ltrs.
20 gallons US 16.66 gallons, Imp.
- 8. Seating capacity Four-(4)
- (**) 9. Weight - total weight of car with normal equipment, water, oil and spare wheel but without fuel or repair tools. 1452 kg 3195 lbs

STAMP

STAMP

CHASSIS & BODYWORK - Photos A, B, C

- (**) 20. Chassis/body construction - ~~separate~~ unit construction
- (**) 21. Unit construction - material/s Sheet Steel
- (**) 22. Chassis - material/s steel separate construction
- (**) 23. Body - material/s steel separate construction
- (**) 24. Doors - number two (2) material/s Steel
- (**) 25. Hood - material/s Steel
- (**) 26. Trunk Lid - material/s Steel
- 27. Window, Rear - material/s Glass
- 28. Windshield - material/s Glass
- 29. Windows, front door - material/s Glass
- 30. Windows, rear door - material/s None
- 31. Windows - actuating system Regulator
- 32. Window, rear quarter - material/s Glass

ACCESSORIES AND UPHOLSTERY

- 38. Heating, interior - yes no Optional
- 39. Air conditioning - yes no Optional
- 40. Ventilation - yes no
- (*) 41. Seats, front - type of seat and upholstery Bucket/Vinyl
- 42. Seats, front - weight
 (complete with supports & rails out of car) 14.8 kg 32.5 lbs (ea)
- CHECK: BENCH _____ BUCKET X CONSOLE INCLUDED _____
- 43. Seats, rear - type of seat and upholstery Bench/Vinyl
- 44. Bumper, front - material/s Steel kg 5.13 lbs 11.3 Weight
- 45. Bumper, rear - material/s Steel kg 5.76 lbs 12.7 Weight

WHEELS

- 50. Type Steel
- 51. Weight (per wheel, without tire) 8.9 kg 19.5 lbs
- 52. Method of attachment Stud and Nut (5)
- 53. Rim, diameter 356/381 mm 14/15 in
- 54. Rim, width 152/152 mm 6/6 in

STEERING

- 60. Type Recirculating Ball and Nut
- 61. Servo assistance Optional
- 62. Number of turns of steering wheel from lock to lock 4.64
- 63. In case of servo assistance 3.74

STAMP

STAMP

SUSPENSION

- (**) 70. Suspension, front (photo D) - type Independent
- (**) 71. Spring - type Coil
- (*) 72. Stabilizer - if fitted Yes
- 73. Shock absorbers - number Two (2)
- 74. Type Tubular-Adjustable
- (**) 78. Suspension, rear (photo E) - type Live Axle
- (**) 79. Spring - type Leaf
- (*) 80. Stabilizer - if fitted No
- 81. Shock absorbers - number Two (2)
- 82. Type Tubular-Adjustable

BRAKES (Photos E and F)

- (**) 90. Method of operation Hydraulic
- (*) 91. Power assisted (if fitted) - type Pedal Boost
- 92. Master Cylinders - number and type One (1) Dual
(indicate if duplex master cylinder) Front Rear
- 93. Cylinders - number per wheel One (1) One (1)
- 94. Cylinders - wheel bore mm in mm in
(indicate stepped bore dimensions if applicable)

Drum Brakes

- | | <u>Front</u> | <u>Rear</u> |
|------------------------------|--------------------------|---------------------------------------|
| 95. Diameter, inside | mm 125.4 | mm 10.0 in |
| 96. Linings, length | mm 149.12 | mm 19.34 in |
| 97. Linings, width | mm 150.8 | mm 2.0 in |
| 98. Shoes - number per brake | | Two (2) |
| 99. Area, total - per brake | mm ² 24,916.1 | mm ² 38.68 in ² |

Disc Brakes

- | | | | | |
|------------------------------|--------------------------|-----------------------|-----------------|-----------------|
| 100. Diameter, outside | 287 mm | 11.3 in | mm | in |
| 101. Thickness of disc | 23.81 mm | .9375 in | mm | in |
| 102. Lining - length | 124.5 mm | 4.9 in | mm | in |
| 103. Lining - width | 52.6 mm | 2.07 in | mm | in |
| 104. Pads - number per brake | | Two (2) | | |
| 105. Area, total - per brake | 13,097.4 mm ² | 220.2 in ² | mm ² | in ² |

STAMP

STAMP

MAKE Ford

MODEL '69 Mustang 428 HT

FIA REC # 5253 428

M

H.T.

G1

ENGINE (Photos J and K)

- (**) 130. Cycle two four Wankel
- (**) 131. Cylinders - number Eight
- (**) 132. Cylinders - arrangement VEE Wankel - # of elements and basic dimensions
- (**) 133. Bore 104.95 mm 4.132 in
- (**) 134. Stroke 101.19 mm 3.984 in
- (**) 135. Cylinders - capacity 875.4 cm³ 53.42 in³
- (**) 136. Cylinders, total capacity 7003.2 cm³ 427.36 in³
- (**) 137. Cylinder Block - material/s Cast Iron
- (**) 138. Sleeves - material/s (if fitted) None
- (**) 139. Head, cylinder - material/s Cast Iron number fitted Two (2)
- (**) 140. Port, inlet - number Eight (8)
- (**) 141. Port, exhaust - number Eight (8)
- (*) 142. Compression - ratio 10.6:1
- (*) 143. Combustion chamber - volume ~~1188.0~~ cm³ 72.5 in³
- (*) 144. Piston - material/s Aluminum Alloy with Steel Struts
- (*) 145. Rings - number Three (3)
- (*) 146. Distance from gudgeon pin centre line to highest point of piston crown 42.67 mm 1.680 in
- (**) 147. Crankshaft - cast-forged-mach from solid
- (**) 148. Crankshaft - type - integral - sectioned - # of sections
- (**) 149. Crankshaft, main bearings - number Five (5)
- (**) 150. Bearing cap - material/s Cast Iron
151. Lubrication - system - dry sump/oil in sump
152. Lubricant - capacity 4.72 ltrs pts 5 qts US
- (*) 153. Cooler, oil - yes no
154. Cooling - method Water Radiator
155. Cooling - capacity of system 19.39 ltrs pts 20.5 qts US

STAMP

STAMP

MAKE Ford

MODEL '69 Mustang 428 HT FIA REC # 5253

M
428
H.T.
G1

- (*) 156. Fan, cooling (if fitted) - diameter 46.35 cm 18.25 in
(*) 157. Fan, cooling - number of blades seven (7) material/s Steel

BEARINGS

- (**) 158. Crankshaft, main - type Insert diameter 69.81mm 2.7488 in
(**) 159. Connecting rod, big end - type Insert diameter 61.94 mm 2.4384 in

WEIGHTS

- (*) 160. Flywheel (clean) 12.92 kg 28.5 lbs
(*) 161. Flywheel with clutch (all rotating parts) 24.44 kg 53.91 lbs
(*) 162. Crankshaft 29.70 kg 65.5 lbs
163. Connecting Rod .940 kg 2.07 lbs
(*) 164. Piston with rings & pin 1.853 kg 4.07 lbs

FOUR CYCLE ENGINES

- (**) 170. Camshafts - number one (1) material/s Allow Iron
(**) 171. Camshaft - location Cylinder Block
(**) 172. Camshaft Drive, type Chain
(**) 173. Valve operation - type Tappet, Pushrod, Rocker

INLET (See Photo P) (for addtl info re 2 stroke engines and super charged, see page 15)

180. Inlet manifold - materials Cast Iron
181. Valves (overall) - diameter 53.26 mm 2.097 in
(*) 182. Valve lift - maximum 12.7 mm .500 in
183. Springs, valve - number Two (2)
184. Spring - type Coil and Flat
(**) 185. Valves, per cylinder - number One (1)
(*) 186. Tappet - clearance for checking timing (cold) Hydraulic mm in
(*) 187. Valves - open at (with tolerance for tappet clearance indicated) 18° BTC
(*) 188. Valves - close at (with tolerance for tappet clearance indicated) 72° ABC
(*) 189. Air filter - type Dry Element

STAMP

STAMP

MAKE Ford

MODEL '69 Mustang 428

HTA REC # 5253

M
428
H.T.
G1

EXHAUST (See Photo Q)

195. Manifold, exhaust - material/s Cast Iron
196. Valves (overall) - diameter 42.16 mm 1.660 in
197. Valve, lift - maximum 12.7 mm .500 in
198. Valve Springs/valve - number Two (2)
199. Springs - type Coil and Flat
- (**) 200. Valves - number per cylinder One (1)
- (*) 201. Tappet - clearance for checking timing (cold) Hydraulic
mm in
- (*) 202. Valves - open at (with tolerance for tappet 82° BBC
clearance indicated)
- (*) 203. Valves - close at (with tolerance for tappet 28° ATC
clearance indicated)

CARBURETION (See Photo N)

210. Carburetors, fitted - number One (1)
211. Type Downflow
- (*) 212. Make Autolite
- (*) 213. Model 9510
214. Carburetors - number of mixture passages Four (4)
- (*) 215. Carburetor - flange hole diameter of exit port
42.86 mm 1.6875 in
216. Venturi - throat diameter+ 31.75 mm 1.25 PRI in
35.05 1.38 SEC.

INJECTION

220. Pump - make NONE FITTED
221. Plungers - number
- (*) 222. Pump - model
223. Injectors - location
224. Injectors - total number
- (*) 225. Inlet pipe - minimum diameter mm in

+ For variable throat type carburetors, indicate minimum lift of shutter mechanism such as pistons in S.U.

STAMP

STAMP

(10)

MAKE Ford

MODEL '69 Mustang 428 HTFIA REC #5253

M
428
H.T.
G1

ENGINE ACCESSORIES

- (*) 230. Pump, fuel - mechanical and/or electrical.
231. Number fitted One (1) each - Two (2) total
232. Ignition system - type Battery and Coil
233. Distributors - number One (1)
234. Coils, ignition - number One (1)
235. Spark plugs - number per cylinder One (1)
236. Generator (or Alternator) - number fitted One (1)
237. Drive - method Belt
238. Voltage, generator - volts 12.8
239. Battery - number One (1)
240. Location Engine Compartment or Trunk
241. Voltage - volts 12 amp hrs 80

ENGINE & CAR PERFORMANCE as declared by mfr. in catalogue

- (*) 250. Horsepower - maximum engine output 335 at 5200 rpm S.A.
(indicate SAE or DIN)
(*) 251. RPM - maximum 5200 output at that figure 335 S.A.E.
(*) 252. Torque - maximum 440 at 3400 rpm
(*) 253. Speed - maximum km/hour miles/hour

DRIVE TRAIN

Clutch

260. Type Dry Plate
261. Plates - number of driven One (1)
262. Plates - diameter 27.94 cm 11.0 in
263. Linings - diameter - inside 17.78 cm 7.0 in
Linings - diameter - outside 27.94 cm 11.0 in
264. Method of operation Mechanical

STAMP

STAMP

Gear Box (Photo H)

- (**) 270. Manual type - make Ford
- (**) 271. Ratios, forward - number Four (4)
- 272. Ratios, forward - number synchronized Four (4)
- 273. Gear-Shift - location floor optional
- (**) 274. Automatic - make Ford type Hydraulic with Planetary Gears and Torque Converter.
- (**) 275. Ratios, forward - number Three (3)
- 276. Gear-Shift - location Floor

| 277. | Manual | | Automatic | | Alternative manual/automatic | | | |
|---------|--------|---------------------------------|-----------|--|------------------------------|---------|-------|---------|
| | Ratio | # Teeth | Ratio | # Teeth | Ratio | # Teeth | Ratio | # Teeth |
| 1 | 2.32 | $\frac{23}{25}$ $\frac{32}{15}$ | 2.46 | | | | | |
| 2 | 1.69 | $\frac{23}{25}$ $\frac{28}{18}$ | 1.46 | Torque Converter Maximum Ratio at Stall 2.02:1 | | | | |
| 3 | 1.29 | $\frac{23}{25}$ $\frac{25}{21}$ | 1.00 | | | | | |
| 4 | 1.00 | Direct | | | | | | |
| 5 | | | | | | | | |
| 6 | | | | | | | | |
| reverse | 2.78 | | 2.20 | | | | | |

- 278. Overdrive - type NONE FITTED
- 279. Forward gears on which overdrive can be selected
- 280. Overdrive - ratio

FINAL DRIVE

- (**) 290. Type Hypoid, Semi-Floating, Straddle mounted pinion
- (**) 291. Differential - type Locking-By Ratchet or Friction
- (**) 292. Limited Slip Differential (if fitted) - type / Positive locking-by Ratchet or Friction.
- 293. Ratio 3.00 3.25 3.50 3.70 3.91 4.30
- Teeth - number $\frac{39}{13}$ $\frac{39}{12}$ $\frac{35}{10}$ $\frac{37}{10}$ $\frac{43}{11}$ $\frac{43}{10}$
- (/) Specify friction or positive locking type
- STAMP STAMP

IMPORTANT

The conformity of the car with the following items of the present recognition form is to be disregarded during the technical inspection when the vehicle has been entered in Group II (Touring Cars) or III (Grand Touring Cars):
41, 72, 80, 91, 142, 143, 144, 145, 146, 153, 156, 157, 160, 161, 162, 163, 164, 182, 186, 187, 188, 189, 201, 202, 203, 212, 213, 215, 216, 222, 225, 230, 250, 251, 252, 253, 255, photos I, M, N & items on page 5 as indicated.

During the technical inspection of cars entered in Group IV (Sports Cars) only the following items of the present recognition form are to be taken into consideration:
1, 2, 3, 9, 20, 21, 22, 23, 24, 25, 26, 70, 71, 78, 79, 90, 130, 131, 132, 133, 134, 135, 136, 137, 138, 139, 140, 141, 147, 148, 149, 150, 158, 159, 170, 171, 172, 173, 185, 200, 270, 271, 274, 275, 290, 291, 292 & photos A, B, D, E, F, G, H, J, K, O.

Optional equipment affecting preceding information:

CATALOGUE PART NUMBER MUST BE GIVEN

- S7MS-6675-B Sump Guard
- C9ZF-90646 Hood Scoop Package - Die Cast
- C9ZB-16C664-A Hood Scoop Package - Fiberglass

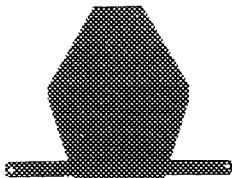

Sump Guard

STAMP

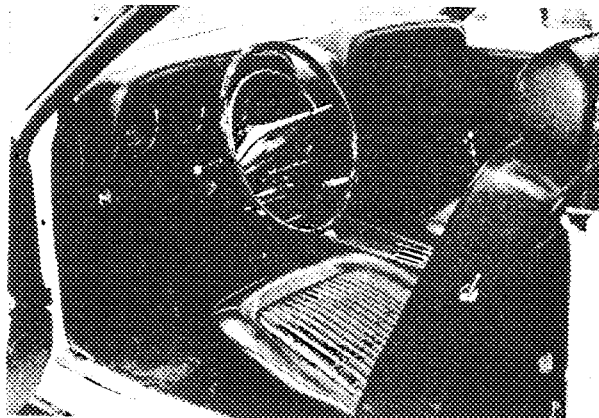

Interior with Automatic Shift

STAMP

MAKE FORD '69 MUSTANG
MODEL 428 H.T. FIA REC # 5253 M
428
H.T.
G1

Optional Equipment - CATALOGUE PART NUMBER MUST BE GIVEN

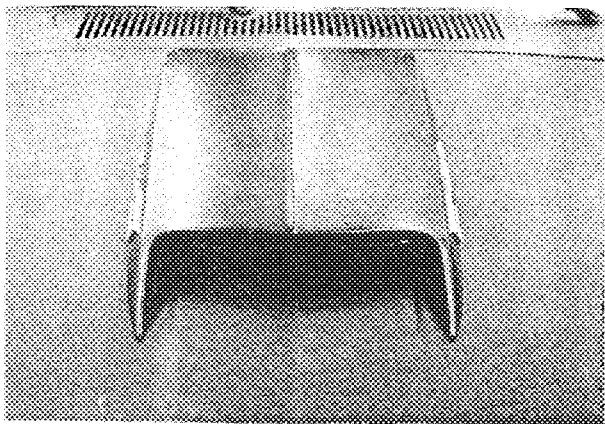

Hood Scoop Package - Fiberglass

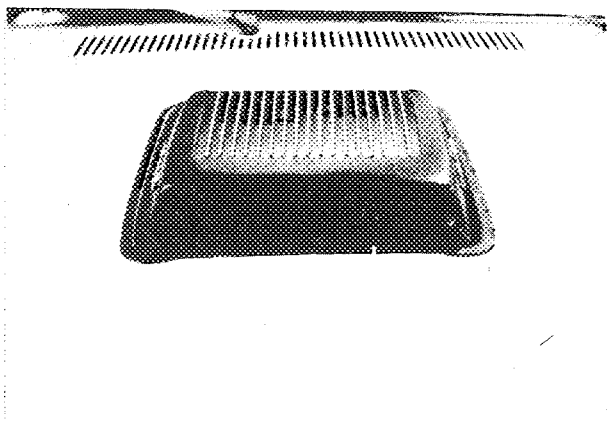

Hood Scoop Package - Die Cast

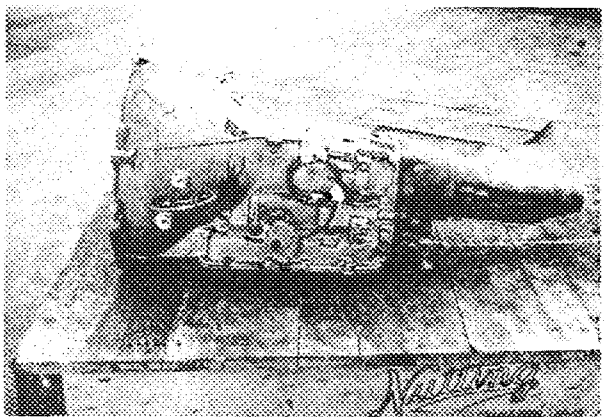

Automatic Gearbox Photo "H"

STAMP

STAMP