

# FEDERATION INTERNATIONALE DU SPORT AUTOMOBILE

FISA Homologation No

A-5473



## JAPAN AUTOMOBILE FEDERATION

社団法人 日本自動車連盟

Groupe  
Group A/吾  
グループ

JAF公認番号 JA-151  
JAF公認グループ  
JAF発効年月日 1992年 10月 31日

FICHE D'HOMOLOGATION CONFORME A L'ANNEXE J DU CODE SPORTIF INTERNATIONAL  
HOMOLOGATION FORM IN ACCORDANCE WITH APPENDIX J OF THE INTERNATIONAL SPORTING CODE  
国際スポーツ法典付則J項(及びJAF国内競技車両規則)に従った公認書式

Homologation valable à partir du  
Homologation valid as from  
FISA発効年月日

01 JAN. 1993

A) Voiture vue de 3/4 avant  
Car seen from 3/4 front  
3/4前が見える車体全体

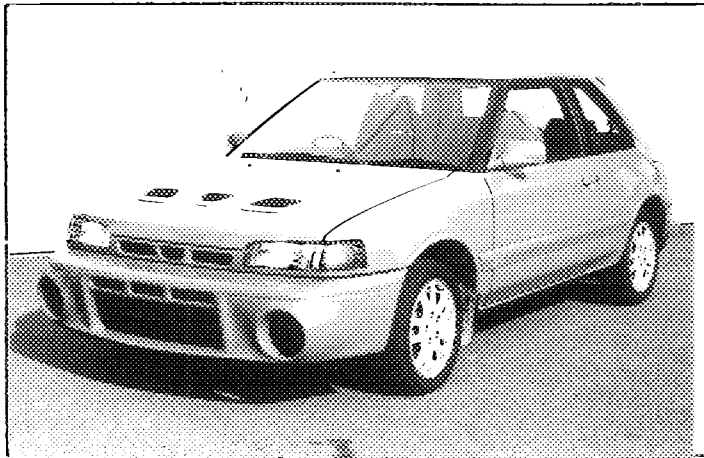

B) Voiture vue de 3/4 arrière  
Car seen from 3/4 rear  
3/4後が見える車体全体



### 1. GENERALITES / GENERAL / 一般項目

101. Constructeur  
Manufacturer  
製造会社名

MAZDA MOTOR CORPORATION

102. Dénomination(s) commerciale(s) - Modèle et type  
Commercial name(s) - model and type  
通称名 - 形式とロケ

MAZDA FAMILIA GT-R 4WD (BG8)

103. Cylindrée

Cylinder capacity 1839.6 cm<sup>3</sup>

Cylindrée corrigée

Corrected cylinder capacity 1839.6 × 1.7 = 3127.5 cm<sup>3</sup>

104. Mode de construction :  
Type of car construction :  
車体構造の形式 :

a) Mode :  
Type :  
形式 :

-séparée  
-separate

monocoque  
unitary construction  
モノコック

b) matériau du châssis / coque  
material of chassis / bodyshell  
シャシ/車体の材質

STEEL

105. Nombre de volumes  
Number of volumes  
エアー・タンクの数

2

106. Nombre de places  
Number of places  
定員

5

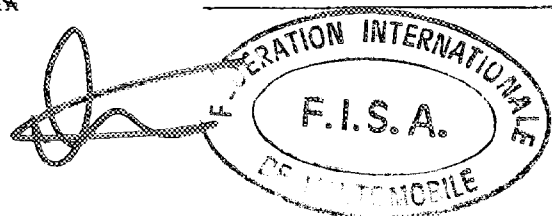

Marque  
Make  
会社名 MAZDA

Modèle  
Model  
型式 FAMILIA GT-R

FISA Homologation No

A-5473

許可符号 JA-151

2. DIMENSIONS, POIDS / DIMENSIONS, WEIGHT / 寸法, 重量

202. Longueur hors-tout  
Overall length  
全長

4.080 mm ± 1%

203. Largeur hors-tout  
Overall width  
全幅  
Endroit de mesure  
Where measured  
測定箇所

1.695 mm ± 1%

AT REAR AXLE

204. Largeur de carrosserie  
Width of bodywork  
車体の幅

a) A la hauteur de l'axe avant  
At front axle  
前軸線上の車体幅

1690 mm ± 1%

b) A la hauteur de l'axe arrière  
At rear axle  
後軸線上の車体幅

1695 mm ± 1%

206. Espacement  
Wheelbase  
軸間

2450 mm ± 1%

209. Porte à faux  
Overhang  
オーバーハング

a) Avant  
Front  
前

865 mm ± 1%

b) Arrière  
Rear  
後

765 mm ± 1%

210. Distance "G" (volant-paroi de séparation arrière)  
Distance "G" (steering wheel-rear bulkhead)  
寸法 "G" (ステアリングホイール - 後部分離壁)

1.570 mm

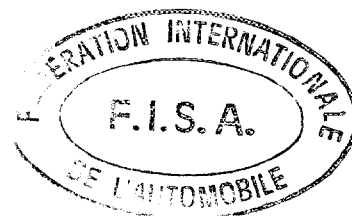
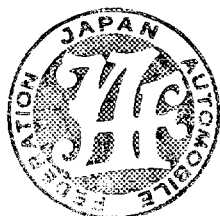

Marque  
Make  
会社名

MAZDA

Modèle  
Model  
型式

FAMILIA GT-R

FISA Homologation No

A-5473

車台番号 JA-151

3. MOTEUR/ENGINE/エンジン

(en cas de moteur rotatif, voir Art.335 sur fiche additionnelle)  
(in case of rotative engine, see Art.335 on additional form)  
(回転式の場合、別添形式第235号参照)

301. Emplacement et position du moteur  
Location and position of the engine  
エンジンの位置と向き

INCLINATION (L/R) : 0°  
FRONT, TRANSVERSE, VERTICAL ANGLE : 10°

303. Cycle  
Cycle  
サイクル 4 OTTO

C) Profil droit du moteur déposé  
Right hand view of dismounted engine  
奥面から取り外したエンジンの右側面

D) Profil gauche du moteur déposé  
Left hand view of dismounted engine  
奥面から取り外したエンジンの左側面

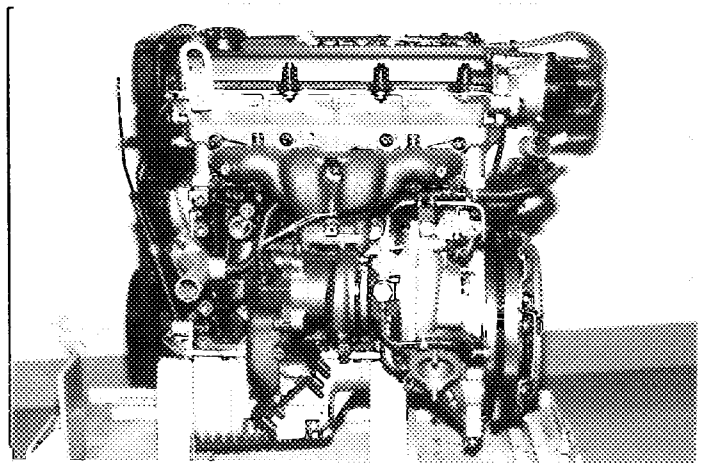
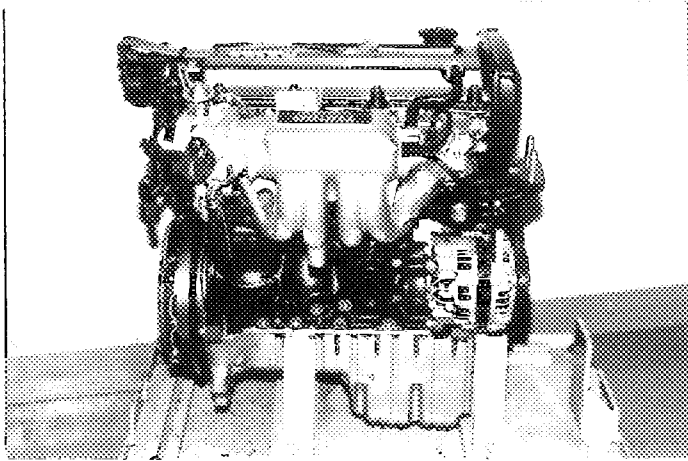

E) Moteur dans son compartiment  
Engine in its compartment  
奥面に取付けたエンジン

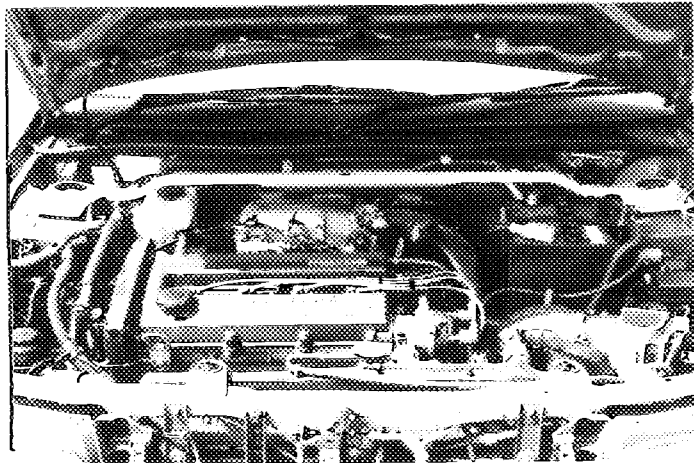

304. Suralimentation  
Supercharging  
過給機

oui	<del>non</del>
yes	<del>no</del>
有	<del>無</del>

(en cas de suralimentation, voir Art.334 sur fiche additionnelle)  
(in case of supercharging, see Art.334 on additional form)  
(過給機の場合、別添形式第334号参照)

Type et nombre de compresseurs  
Type and number of compressors  
エアレートの型式と数

EXHAUST TURBOCHARGER, 1 UNIT

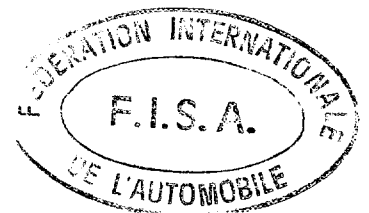

Marque  
Make  
会社名

MAZDA

Modèle  
Model  
型式

FAMILIA GT-R

FISA Homologation No

A-5473

許可証番号 JA-151

305. Nombre et disposition des cylindres  
Number and layout of cylinders  
シリンダー数と配置

4 IN LINE

306. Mode de refroidissement  
Type of cooling  
冷却装置

LIQUID

307. Cylindrée  
Cylinder capacity  
気筒容量

a) Unitaire  
Unitary  
1気筒

460.0

b) Totale  
Total  
合計

(1839.6 × 1.7 =) 3127.5

c) Totale max. autorisée  
Max. total allowed  
許される最大排気量

3172.5

INDICATION NON VALABLE EN GROUPE N  
NOT VALID FOR GROUP N  
グループNには有効ではない

312. Matériau du bloc - cylindre  
Cylinder block material  
シリンダーブロックの材質

CAST-IRON

313. Chevises :  
Sleeves :  
スリーブ :

a) oui non  
yes no  
有 無

c) humides sèches  
wet dry  
湿式 乾式

314. Alésage  
Bore  
径

83.0

315. Alésage maximum autorisé  
Maximum bore allowed  
許される最大径

83.6

316. Course  
Stroke  
ストローク

85.0

INDICATION NON VALABLE EN GROUPE N  
NOT VALID FOR GROUP N  
グループNには有効ではない

318. Bielle :  
Connecting rod :  
コネクティングロッド :

a) Matériau  
Material  
材質

STEEL

b) Type de la tête de bielle  
Bigend type  
ビッグエンド形式

SEPARATE

c) Diamètre intérieur de la tête de bielle (sans coussinets)  
Interior diameter of the big end (without shell bearings)  
ビッグエンドの内径(ベアリングを除く)

48.0

mm ± 0.1%

d) Longueur entre axes  
Length between the axes  
エンドの長さ

132.9

± 0.1mm

e) Poids minimum  
Minimum weight  
最低重量

562

g

319. Vilebrequin  
Crankshaft  
クランクシャフト

a) Type de construction  
Type of manufacture  
製造の形式

INTEGRAL

b) Matériau  
Material  
材質

STEEL

c) ~~coûlé~~ forgé  
~~cast~~ forged  
~~鑄造~~ 鍛造

d) Nombre de paliers  
Number of bearings  
ベアリングの数

5

e) Type de paliers  
Type of bearings  
ベアリングの形式

PLAIN

f) Diamètre des paliers  
Diameter of bearings  
ベアリングの外径

54.0

mm ± 0.2%

g) Matériau des chapeaux de paliers  
Bearing caps material  
ベアリングキャップの材質

CAST-IRON

h) Poids minimum du vilebrequin nu  
Minimum weight of bare crankshaft  
クランクシャフト単体の最低重量

15588

g

320. Volant moteur / Flywheel /  
クランクシャフト :

a) Matériau / Material / 材質

b) Poids minimum avec  
couronne de démarreur  
Minimum weight with  
starter ring  
クランクシャフトとスターターの最低重量

Boîte manuelle / Manual gearbox  
マニュアルギアボックス

CAST-IRON

8652

Boîte automatique / Automatic gearbox  
オートマチックギアボックス

XXXXX

XXXXX

Utilisable uniquement avec boîte de vitesses automatique  
Only usable with an automatic gearbox  
オートマチックギアボックスの使用のみ



Marque  
Make  
会社名 MAZDA

Modèle  
Model  
型式 FAMILIA GT-R

FISA Homologation No

A-5473

JAF公認番号 JA-151

321. Culasse : a) Nombre  
Cylinderhead : Number 1  
シリンダーヘッド 数  
b) Matériau  
Material ALUMINUM ALLOY  
材質

e) Angle entre soupape d'admission et la verticale  
Angle between intake valve and vertical 25°  
シリンダーヘッドと垂直線との角度

f) Angle entre soupape d'échappement et la verticale  
Angle between exhaust valve and vertical 25°  
シリンダーヘッドと垂直線との角度

F) Culasse nue  
Bare cylinderhead  
シリンダーヘッド本体

G) Chambre de combustion  
Combustion chamber  
燃焼室

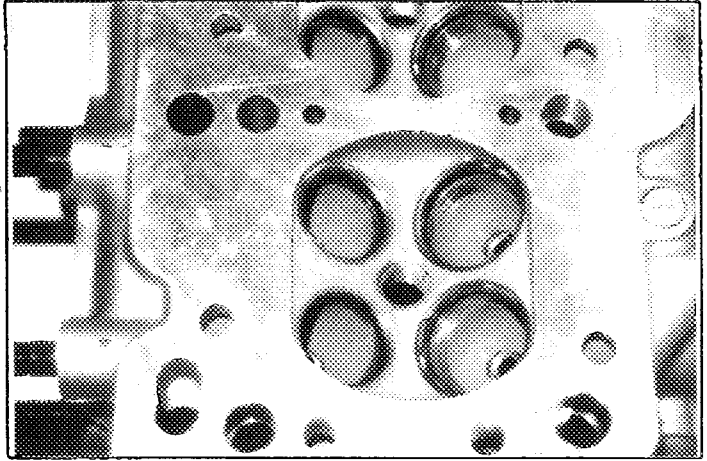
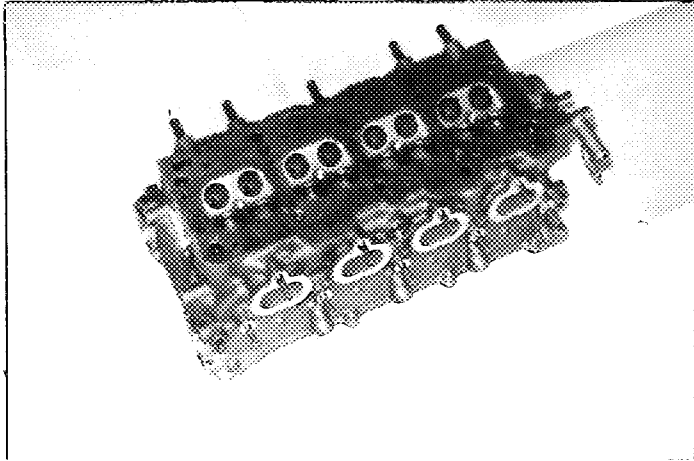

323. Alimentation par carburateur :  
Fuel feed by carburettor :

シリンダー方式 :  
b) Type  
Type XXXXX  
形式

d) Nombre de passages de gaz par carburateur  
Number of mixture passages per carburettor XXXXX  
シリンダー出口の数

e) Diamètre maximum de la sortie de gaz du carburateur  
Maximum diameter of the carburettor mixture exit port XXXXX mm  
シリンダー出口の最大内径

f) Diamètre du diffuseur au point d'étranglement maximum  
Diameter of the venturi at the narrowest point XXXXX ±0.25mm  
ベンチュリ径

a) Nombre de carburateurs  
Number of carburetors XXXXX  
シリンダーの数

c) Marque et modèle  
Make and model XXXXX  
会社名と型式

H) Carburateur(s)  
Carburettor(s)  
シリンダー

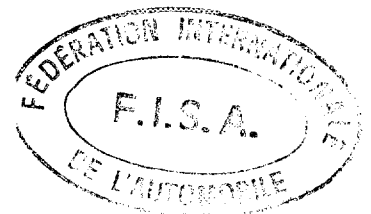
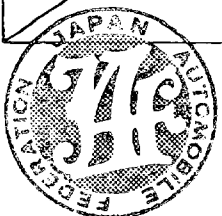
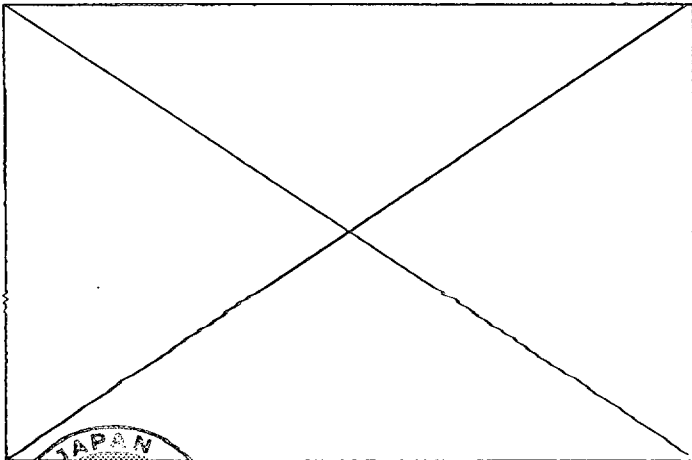

Marque  
Make  
会社名 MAZDA

Modèle  
Model  
型式 FAMILIA GT-R

FISA Homologation No  
A-3473

FFC登録番号 JA-151

324. Alimentation par injection :  
Fuel feed by injection :  
噴射方式

a) Marque  
Make  
会社名 NIPPON DENSO

b) Modèle  
Model  
型式 L-JETRONIC

c) Mode de dosage du carburant :  
Kind of fuel measurement :  
燃料制御方式:

<del>mécanique</del> <del>mechanical</del> <del>機械式</del>	<u>électronique</u> <u>electronic</u> <u>電気式</u>	<del>hydraulique</del> <del>hydraulic</del> <del>油圧式</del>
---	--	--

d) Dimensions du conduit d'admission au niveau du papillon ou de la guillotine  
Dimensions of intake pipe at the throttle or slide location  
20+6または23+6"φのホースが使用可能  
\_\_\_\_\_ 55 \_\_\_\_\_ ±0.25mm

e) Nombre de sorties effectives de carburant  
Number of effective fuel outlets  
ノズルの数  
\_\_\_\_\_ 4 \_\_\_\_\_

f) Position des injecteurs  
Position of injectors  
ノズルの位置

f1) 

<u>Collecteur</u> <u>Manifold</u> <u>マニホールド</u>	<u>Culasse</u> <u>Cylinderhead</u> <u>シリンダーヘッド</u>
---	--

g) Capteurs du système d'injection  
Sensors of injection system  
噴射装置のセンサー  
AIR FLOW METER, INTAKE AIR THERMOSENSOR,  
THROTTLE SENSOR, WATER THERMOSENSOR, ENGINE SPEED SENSOR

h) Actionneurs du système d'injection  
Actuators of injection system  
噴射装置のアクチュエーター  
INJECTOR, ENGINE CONTROL UNIT,  
PRESSURE REGULATOR, AIR VALVE, ISC VALVE

H) Système d'injection  
Injection system  
噴射装置

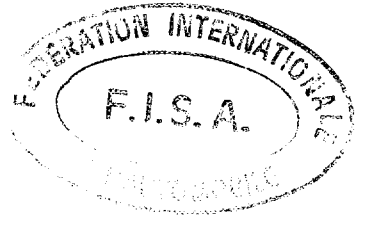
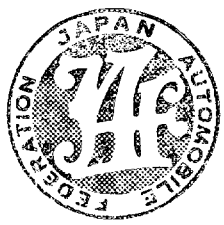
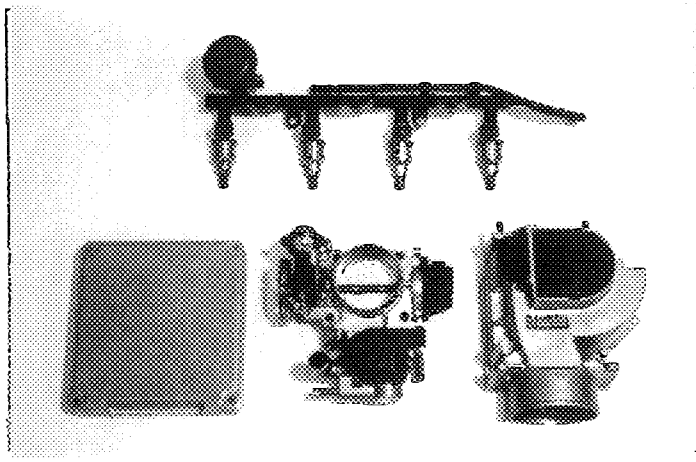

XIV) LOCALISATION DES CAPTEURS ET ACTIONNEURS / LOCATION OF SENSORS AND ACTUATORS / センサとアクチュエータの位置

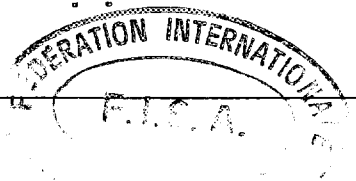
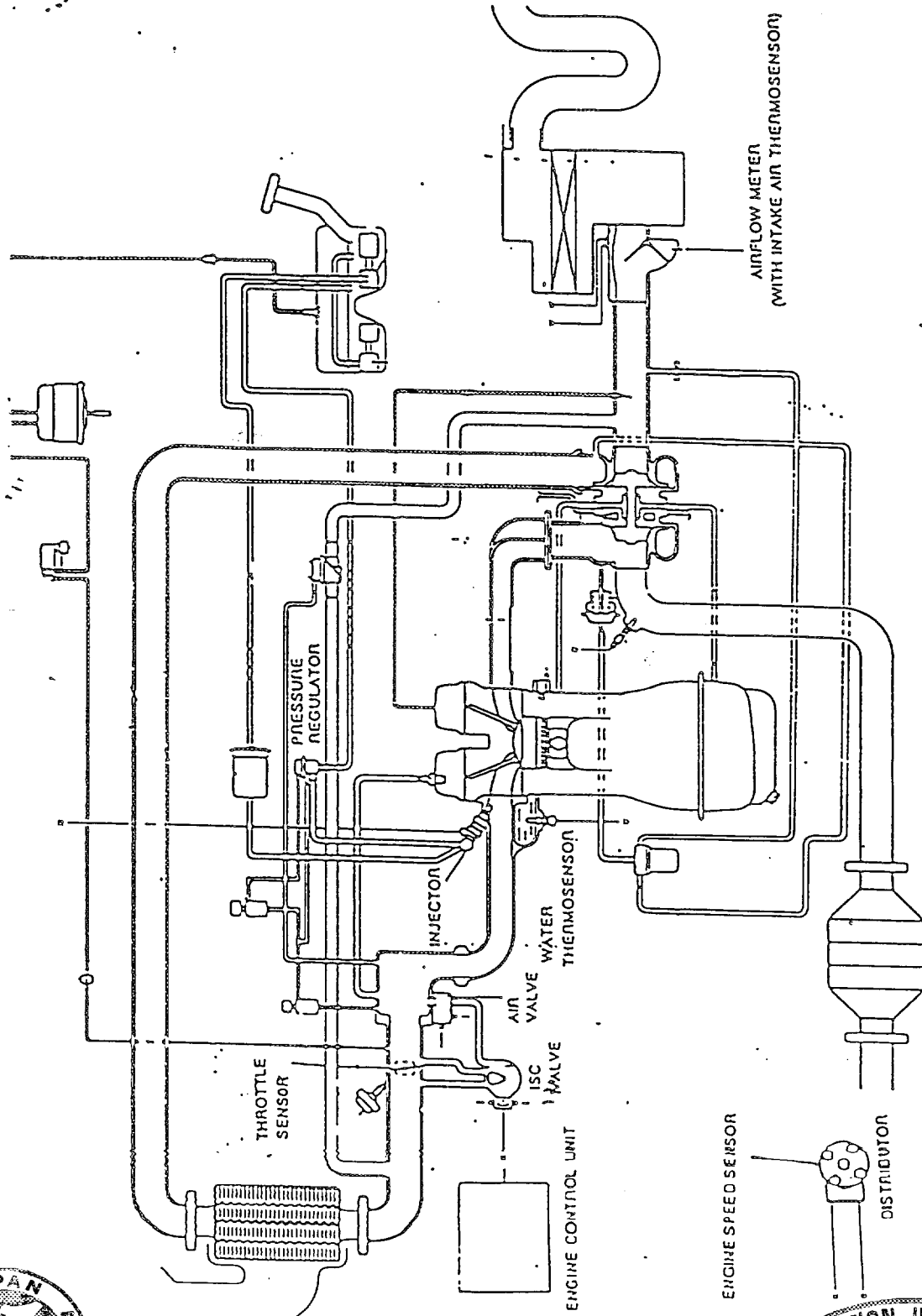

Marque / Make / 会社名: MAZDA

Modèle / Model / 型式: FAMILIA GT-R

FISA Homologation No: 1-5173

車公認番号 JA-151

325. Arbre à cames : a) Nombre / Number: 2  
 b) Emplacement / Location: TOP (DOHC)  
 c) Système d'entraînement / Drive system: NOTCHED BELT  
 d) Nombre de paliers par arbre / Number of bearings per shaft: 5  
 f) Système de commande de soupapes / Type of valve operation: DIRECT

327. Admission : a) Matériau du collecteur / Material of manifold: ALUMINUM ALLOY  
 b) Nombre d'éléments du collecteur / Number of manifold elements: 1  
 c) Nombre de soupapes par cylindre / Number of valves per cylinder: 2  
 d) Diamètre maximum de soupape / Maximum diameter of the valve: 33.1 mm  
 e) Diamètre de tige de soupape dans guide / Diameter of the valve stem in guide: 6.0 ± 0.2 mm  
 f) Longueur de soupape / Valve length: 101.3 ± 1.5 mm  
 g) Type des ressorts de soupape / Type of valve springs: COIL

328. Echappement : a) Matériau du collecteur / Material of manifold: CAST-IRON  
 b) Nombre d'éléments du collecteur / Number of manifold elements: 1  
 c) Dimensions intérieures de sortie collecteur / Internal dimensions of manifold exit: 50 ± 2 mm  
 d) Nombre de soupapes par cylindre / Number of valves per cylinder: 2  
 e) Diamètre maximum de soupape / Maximum diameter of the valve: 28.2 mm  
 f) Diamètre de tige de soupape dans guide / Diameter of the valve stem in guide: 6.0 ± 0.2 mm  
 g) Longueur de soupape / Valve length: 101.4 ± 1.5 mm  
 h) Type des ressorts de soupape / Type of valve springs: COIL

I) Collecteur d'admission / Intake manifold

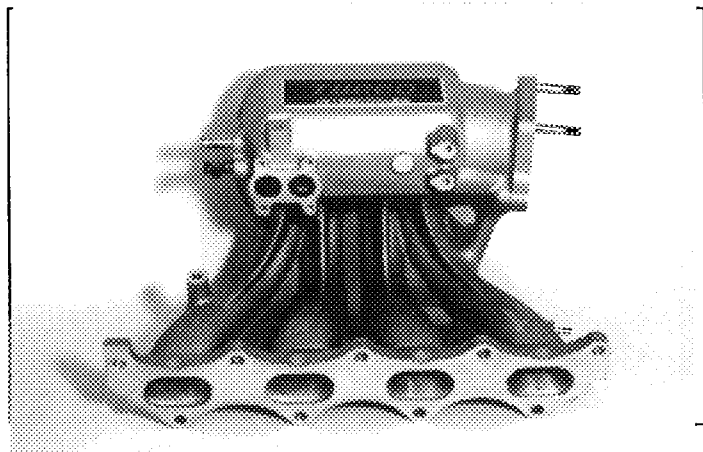

J) Collecteur d'échappement / Exhaust manifold

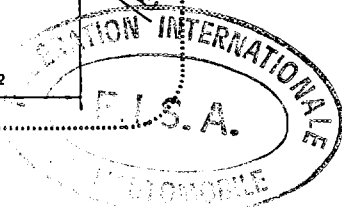
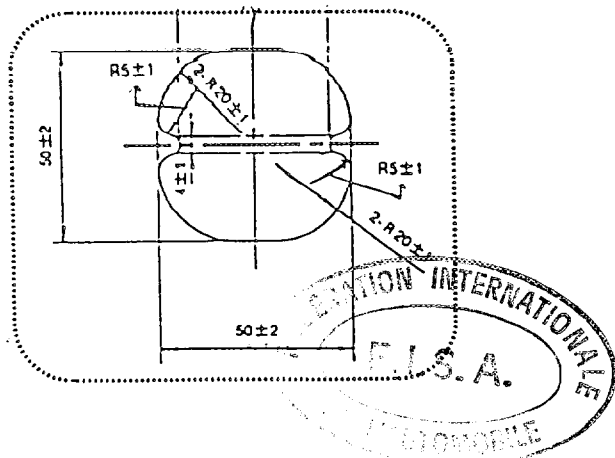
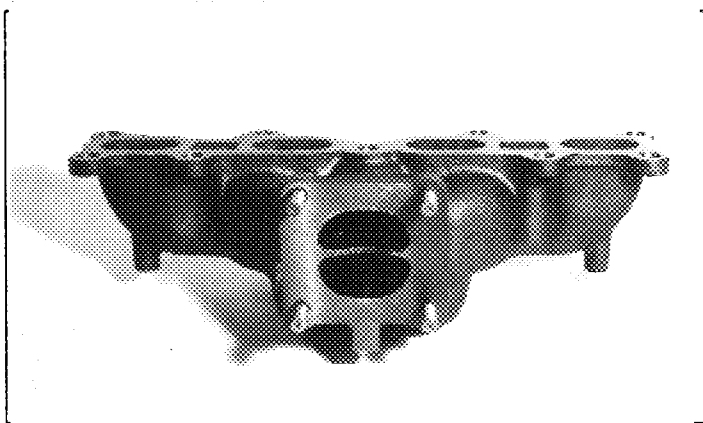



Marque  
Make  
会社名

MAZDA

Model  
Model  
型式

FAMILIA GT-R

FISA Homologation No

A-5473

公認番号 JA-151

Dessins des orifices du moteur - tolérances sur les dimensions :  $-2\%$ ,  $+4\%$

Drawings of engine ports - tolerances on dimensions :  $-2\%$ ,  $+4\%$

寸法の公差 - 寸法公差 :  $-2\%$ ,  $+4\%$

I) Culasse, face collecteur / Cylinderhead, manifold side / シリンダヘッド、マニホールド側

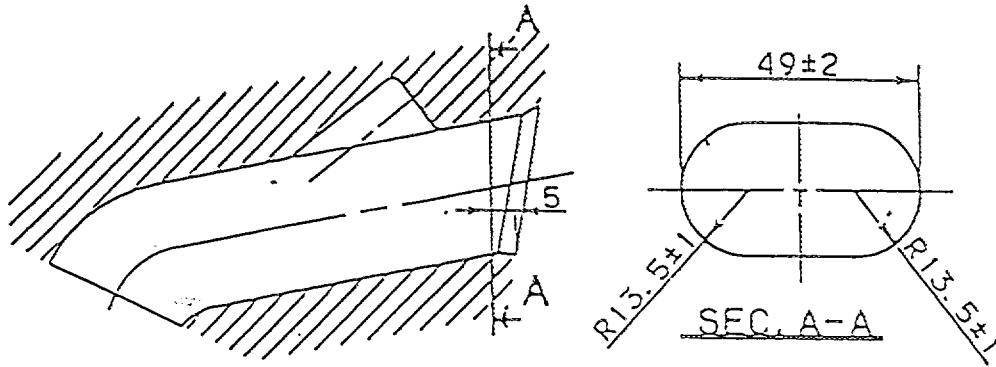

II) Collecteur, côté culasse / Manifold, cylinderhead side / マニホールド、シリンダヘッド側

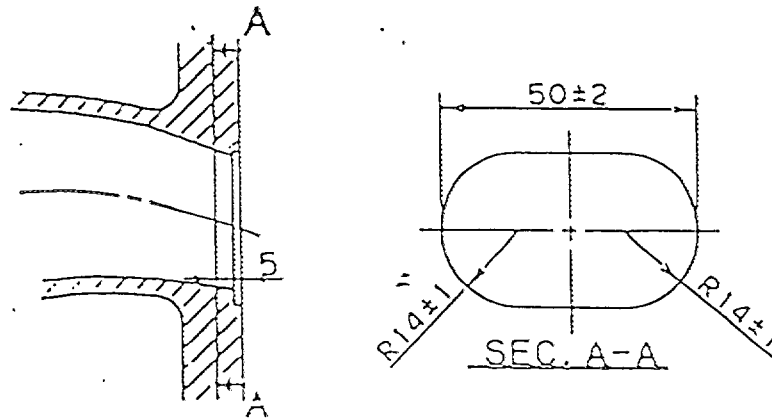

A D M I S S I O N / I N T A K E /



Marque  
Make  
社名

MAZDA

Modèle  
Model  
型式

FAMILIA GT-R

FISA Homologation No

2-5473

公認番号 JA-151

Dessins des orifices du moteur - tolérances sur les dimensions :  $-2\%$ ,  $+4\%$

Drawings of engine ports - tolerances on dimensions :  $-2\%$ ,  $+4\%$

エンジンの図解 - 寸法公差 :  $-2\%$ ,  $+4\%$

I) Culasse, face collecteur / Cylinderhead, manifold side / シリンダヘッドのシリンダ側

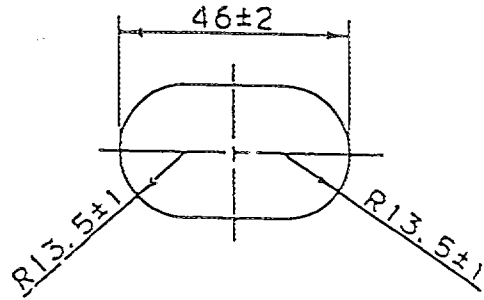
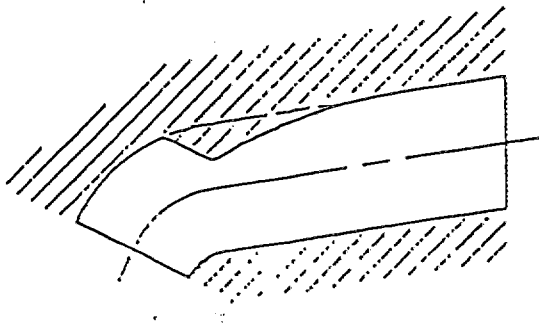

II) Collecteur, côté culasse / Manifold, cylinderhead side / シリンダヘッドのシリンダ側

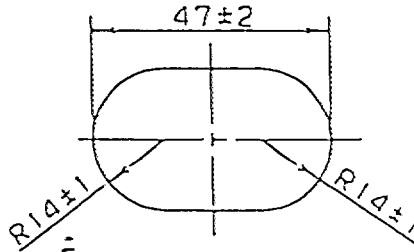
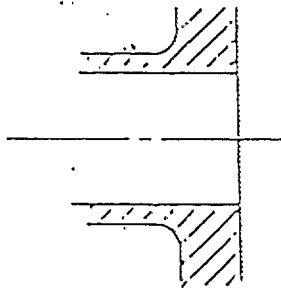

E  
C  
H  
A  
P  
P  
E  
M  
E  
N  
T  
/

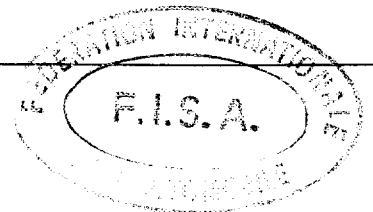

Marque  
Make  
会社名

MAZDA

Modèle  
Model  
型式

FAMILIA GT-R

FISA Homologation No

A-5473

JCF公認番号 JA-151

330. Système d'allumage :  
Ignition system :

点火装置 :

b) Nombre de bougies par cylindre  
Number of plugs per cylinder  
ツワグ-当たりのプラグの数

1

c) Nombre de distributeurs  
Number of distributors  
ディストリビュータの数

1

333. Système de lubrification :  
Lubrication system :

潤滑装置 :

a) Type  
Type  
形式

WET SUMP

b) Nombre de pompes à huile  
Number of oil pumps  
オイルポンプの数

1



Marque  
Make  
会社名

MAZDA

Modèle  
Model  
型式

FAMILIA GT-R

FISA Homologation No

A-5473

JAF公認番号 JA-151

4. CIRCUIT DE CARBURANT/FUEL CIRCUIT/燃料系統

401. Réservoir : a) Nombre  
Fuel tank : Number 1  
置付場所 :  
b) Emplacement Location UNDER THE REAR FLOOR BELOW REAR SEAT  
位置  
c) Matériau Material STEEL  
材質

5. EQUIPMENT ELECTRIQUE/ELECTRICAL EQUIPMENT/電気器具

501. Batteries : a) Nombre b) Tension  
Batteries : Number 1 Tension 12 volts  
バッテリー : 数 電圧

6. TRANSMISSION/POWER TRAIN/駆動系

601. Roues motrices : avant oui non arrière oui non  
Driven wheels : front yes no rear yes no  
駆動輪 : 前 有 無 後 有 無

602. Embrayage : b) Système de commande c) Nombre de disques  
Clutch : Control system HYDRAULIC Number of plates 1  
クラッチ : 制御方式 1.22の枚

603. Boîte de vitesses : a) Emplacement  
Gearbox : Location ATTACHED TO ENGINE IN ENGINE COMPARTMENT  
位置  
b) Marque "manuelle" c) Marque "automatique"  
"Manual" make MAZDA "Automatic" make XXXXX  
マニュアル会社名 自動式会社名  
d) Type et emplacement de commande  
Type and location of control FLOOR  
制御の形式と位置



e) Rapports  
Ratios  
ギア比

	Manuelle/Manual/マニュアル		constant	synchr
	nombre de dents number of teeth 歯数	rapport ratio 比		
1	3.454	38/11		×
2	1.833	33/18		×
3	1.310	38/29		×
4	0.970	33/34		×
5	0.717	33/46		×
6	XXXXX	XXXXX		
AR/R ギア-2	3.166	38/27× 27/12		
Constante Constant	XXXXX	XXXXX		

	Automatique/Automatic/オートマチック		synchr
	nombre de dents number of teeth 歯数	rapport ratio 比	
1	XXXXX	XXXXX	
2	XXXXX	XXXXX	
3	XXXXX	XXXXX	
4	XXXXX	XXXXX	
5	XXXXX	XXXXX	
AR/R ギア-2	XXXXX	XXXXX	

f) Grille de vitesses  
Gear change gate  
シフトパター

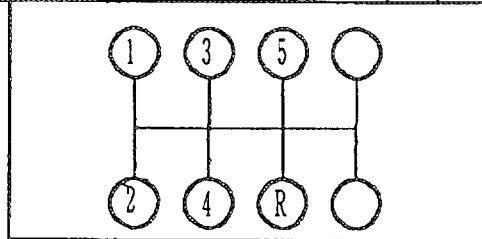

g) Type de lubrification  
Type of lubrication  
潤滑方式

SPLASHING

S) Carter de boîte de vitesses et cloche d'embrayage  
Gearbox casing and clutch bell housing  
ギアボックスとクラッチハウジング

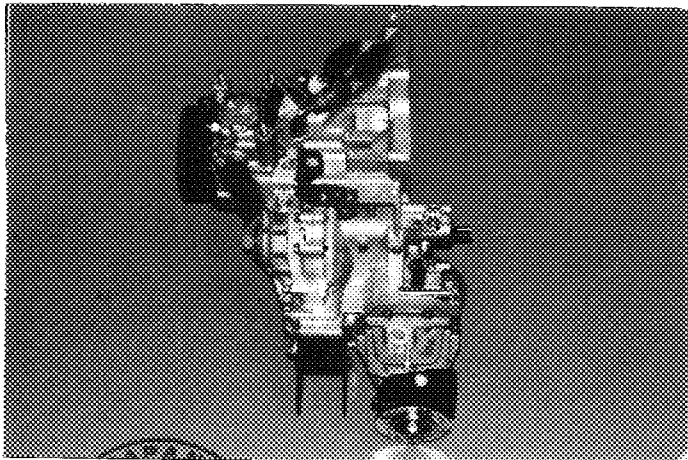

604. Boîte de transfert/différentiel central : a) Rapports / Ratios: 0.255  
 Transfer box/central differential : b) Nombre de dents / Numbers of teeth: 11/37 × 37/43  
 c) Système de commande de boîte de transfert / Control system of transfer box: MECHANICAL  
 d) Type de différentiel central / Type of central differential: PLANETARY GEAR

605. Couple final / Final drive

	Avant / Front / 前	Arrière / Rear / 後
a) Type de couple final / Type of final drive	HERICAL GEAR	HYPOID GEAR
b) Rapport / Ratio	4.214	3.909
c) Nombre de dents / Number of teeth	59/14	43/11
e) Type de lubrification / Type of lubrication	SPLASHING	SPLASHING

606. Arbres : a) Type des arbres longitudinaux / Type of longitudinal shafts: PROPELLER SHAFT WITH UNIVERSAL JOINT AND C. V. J.  
 Shafts : b) Matériau des arbres longitudinaux / Material of longitudinal shafts: STEEL  
 c) Type des demi-arbres transversaux / Type of transversal half-shafts: DRIVE SHAFT WITH C. V. J.  
 d) Matériau des demi-arbres transversaux / Material of transversal half-shafts: STEEL

XII) CHAÎNE CINÉMATIQUE (4 roues motrices) / KINEMATIC TRAIN (4 wheel drive) / 駆動系の図解

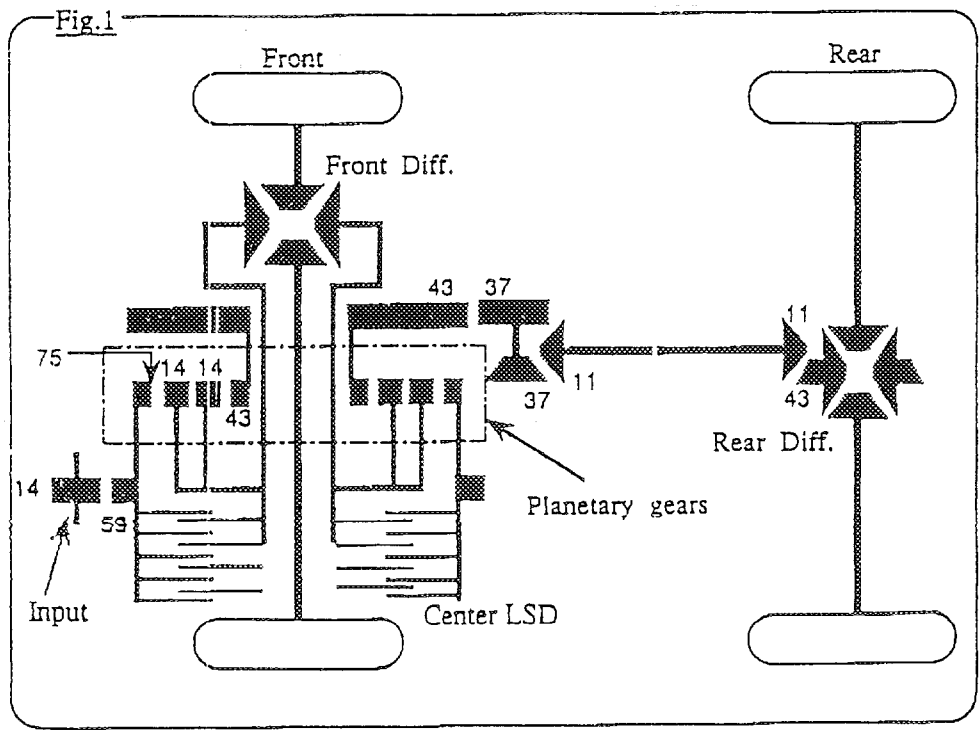

Marque / Make / 会社名 MAZDA

Modèle / Model / 型式 FAMILIA GT-R

A-5473

JAF公認番号 JA-151

7. SUSPENSION / SUSPENSION / サスペンション

701. Généralités / General / 全般

	Avant / Front / 前	Arrière / Rear / 後				
a) Type of suspension / Type of suspension / 形式	INDEPENDENT/MCPHERSON					
702. Ressorts hélicoïdaux / Helicoidal springs / スプリング	<table border="1"> <tr><td>oui / yes / 有</td><td>non / no / 無</td></tr> </table>	oui / yes / 有	non / no / 無	<table border="1"> <tr><td>oui / yes / 有</td><td>non / no / 無</td></tr> </table>	oui / yes / 有	non / no / 無
oui / yes / 有	non / no / 無					
oui / yes / 有	non / no / 無					
703. Ressorts à lames / Leaf springs / リーフスプリング	<table border="1"> <tr><td>oui / yes / 有</td><td>non / no / 無</td></tr> </table>	oui / yes / 有	non / no / 無	<table border="1"> <tr><td>oui / yes / 有</td><td>non / no / 無</td></tr> </table>	oui / yes / 有	non / no / 無
oui / yes / 有	non / no / 無					
oui / yes / 有	non / no / 無					
704. Barres de torsion / Torsion bars / トーションバー	<table border="1"> <tr><td>oui / yes / 有</td><td>non / no / 無</td></tr> </table>	oui / yes / 有	non / no / 無	<table border="1"> <tr><td>oui / yes / 有</td><td>non / no / 無</td></tr> </table>	oui / yes / 有	non / no / 無
oui / yes / 有	non / no / 無					
oui / yes / 有	non / no / 無					

705. Autre type de suspension : / Other type of suspension : / 他形式のサスペンション :

Voir description sur fiche additionnelle / See description on additional form / 追加資料の記述を参照

707. Amortisseurs : / Shock absorbers : / ショックアブソーバー :

	Avant / Front / 前	Arrière / Rear / 後
a) Nombre par roue / Number per wheel / 1車当たり数	1	
b) Type / Type / 形式	TELESCOPIC	
c) Principe de fonctionnement / Principle of operation / 作動原理	HYDRAULIC	

T) Train avant complet déposé / Complete dismantled front axle / 取り外したフロントアクセル一式

U) Train arrière complet déposé / Complete dismantled rear axle / 取り外したリアアクセル一式

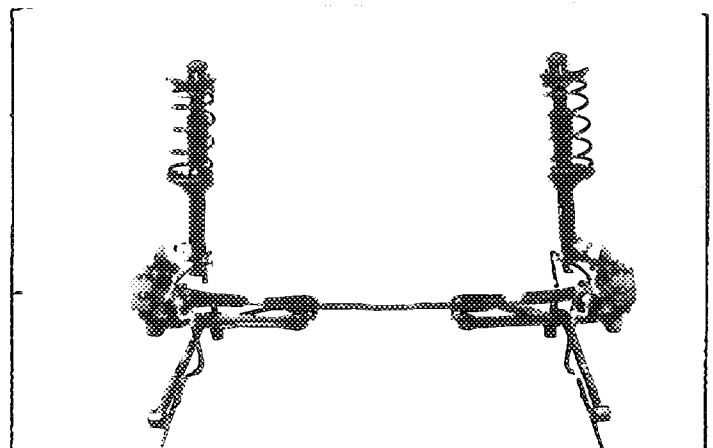
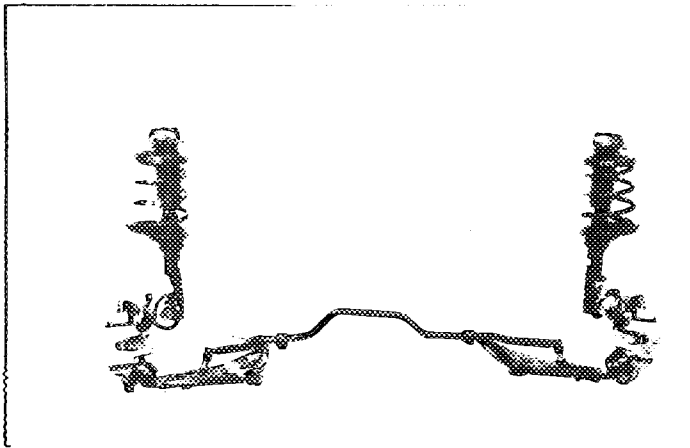

Marque  
Make  
会社名

MAZDA

Modèle  
Model  
型式

FAMILIA GT-R

Registration No

4-5173

JA-151

8. TRAIN ROULANT/RUNNING GEAR/走行装置

01. Roues :  
Wheels :

	Avant / Front / 前	Arrière / Rear / 後
a) Diamètre Diameter 径	15 " / 381 mm	15 " / 381 mm

03. Freins :  
Brakes :

a) Système de freinage  
Braking system

HYDRAULIC

b) Nombre de maître-cylindres  
Number of master cylinders  
マスターシリンダーの数

TANDEM

b1) Alésages  
Bores  
径

25.4

25.4

c) Servo-frein  
Servo-brakes  
サーボブレーキ

oui  
 non  
有 無

c1) Marque et type  
Make and type  
会社名と形式

IIDOSHAKIKI VACUUM

d) Régulateur de freinage  
Braking regulator  
ブレーキレギュレーター

oui  
 non  
有 無

d1) Emplacement  
Location  
位置

IN ENGINE COMPARTMENT

e) Nombre de cylindres par roue  
Number of cylinders per wheel  
1車1当たりシリンダーの数

Avant / Front / 前

Arrière / Rear / 後

1

1

e1) Alésage  
Bore  
径

57.2

34.9

f) Freins à tambours :  
Drum brakes :

f1) Diamètre intérieur  
Internal diameter  
径

XXXXX ± 1.5 mm

XXXXX ± 1.5 mm

f2) Nombre de garnitures par roue  
Number of linings per wheel  
1車1当たりシリンダーの数

XXXXX

XXXXX

f3) Longueur développée des garnitures  
Developed length of linings  
シリンダーの長さ

XXXXX ± 1.5 mm

XXXXX ± 1.5 mm

f4) Largeur des garnitures  
Width of the linings  
シリンダーの幅

XXXXX ± 1 mm

XXXXX ± 1 mm

g) Freins à disques :  
Disc brakes :

g1) Nombre de plaquettes par roue  
Number of pads per wheel  
1車1当たりブレーキパッドの数

2

2

g2) Nombre d'étriers par roue  
Number of calipers per wheel  
1車1当たりブレーキキャリパーの数

1

1

g3) Matériau des étriers  
Caliper material  
キャリパーの材質

CAST-IRON

CAST-IRON

g4) Epaisseur du disque neuf  
Thickness of new disc  
ディスクの厚さ

24.0 ± 1 mm

10.0 ± 1 mm

g5) Diamètre extérieur du disque  
External diameter of the disc  
ディスクの外径

274.0 ± 1.5 mm

280.0 ± 1.5 mm

g6) Diamètre extérieur de frottement  
des plaquettes  
External diameter of pads' rubbing  
surface  
ブレーキパッド摩擦面の外径

272.0 ± 1.5 mm

278.0 ± 1.5 mm

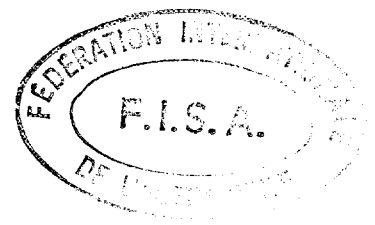



Marque  
Make  
会社名

MAZDA

Modèle  
Model  
型式

FAMILIA GT-R

FISA Homologation No

A-5473

車公認番号 JA-151

- g7) Diamètre intérieur de frottement des plaquettes  
Internal diameter of pads' rubbing surface  
ワキ-摩擦面の内径
- g8) Longueur hors-tout des plaquettes  
Overall length of the pads  
ワキ-の全長
- g9) Disques ventilés  
Ventilated discs  
ベンチレーテッドディスク

Avant / Front / 前		Arrière / Rear / 後	
169.4 ± 1.5 mm		184.2 ± 1.5 mm	
118.0 ± 1.5 mm		95.0 ± 1.5 mm	
<input checked="" type="checkbox"/> oui yes 有	<input checked="" type="checkbox"/> non no 無	<input checked="" type="checkbox"/> oui yes 有	<input checked="" type="checkbox"/> non no 無

- h) Frein de stationnement :  
Parking brake :  
パーキングブレーキ :

- h1) Système de commande  
Control system  
作動方式

CABLE

- h2) Emplacement de commande  
Location of lever  
ワイ-の位置

CENTER ON FLOOR

- h3) Effet sur roues  
On which wheels  
作動ワイ-

Avant Front =前=	Arrière Rear 後
<input checked="" type="checkbox"/>	<input checked="" type="checkbox"/>

- V) Frein avant  
Front brake  
フロントブレーキ

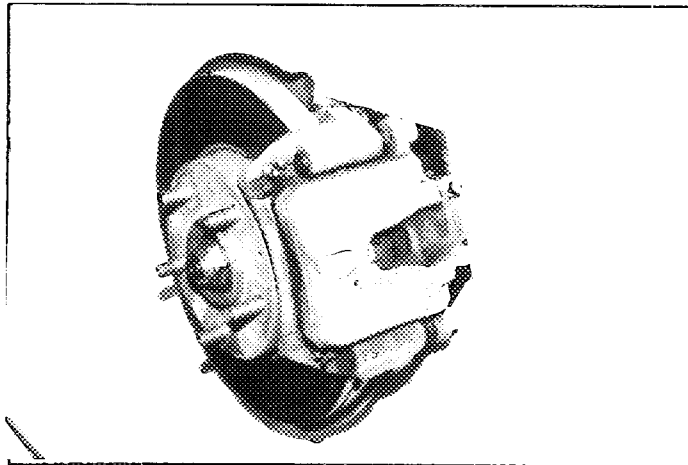

- W) Frein arrière  
Rear brake  
リアブレーキ

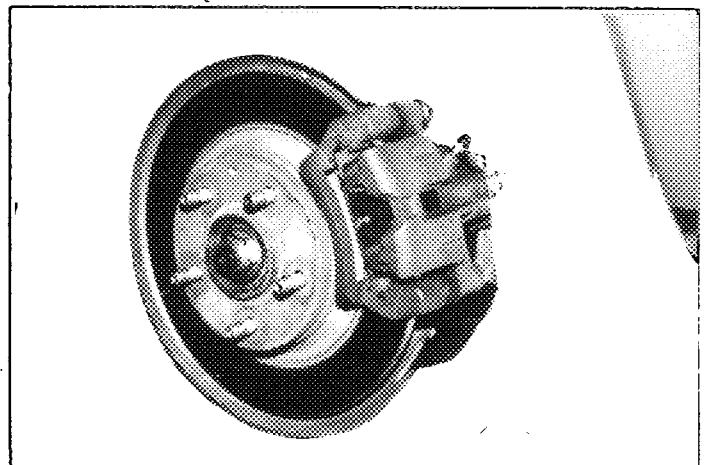

804. Direction :  
Steering :

ステアリング :

- a) Type  
Type  
形式
- b) Servo-assistance  
Power assisted  
パワーアシスト
- Type  
Type  
形式

Avant / Front / 前		Arrière / Rear / 後	
RACK & PINION		XXXXX	
<input checked="" type="checkbox"/> oui yes 有	<input checked="" type="checkbox"/> non no 無	<input checked="" type="checkbox"/> oui yes 有	<input checked="" type="checkbox"/> non no 無
HYDRAULIC		XXXXX	



Marque  
Make  
会社名

MAZDA

Modèle  
Model  
型式

FAMILIA GT-R

FISA Homologation No

5473

JA-151

9. CARROSSERIE / BODYWORK / 車体

901. Intérieur :  
Interior :  
室内 :

a) Ventilation  
Ventilation  
換気

oui  
yes  
有

~~non~~  
~~no~~  
~~無~~

b) Chauffage  
Heating  
ヒーター

oui  
yes  
有

~~non~~  
~~no~~  
~~無~~

f) Toit ouvrant optionnel  
Optional sun roof  
オプションサンルーフ

oui  
yes  
有

~~non~~  
~~no~~  
~~無~~

f1) Type  
Type  
形式

SLIDING & RISING

f2) Système de commande  
Control system  
制御方式

ELECTRICAL

g) Système d'ouverture des vitres latérales  
Opening system for side windows  
サイドウィンドウ開閉方式

Avant / Front / 前	Arrière / Rear / 後
ELECTRICAL	PIVOT

X) Tableau de bord  
Dashboard  
ダッシュボード

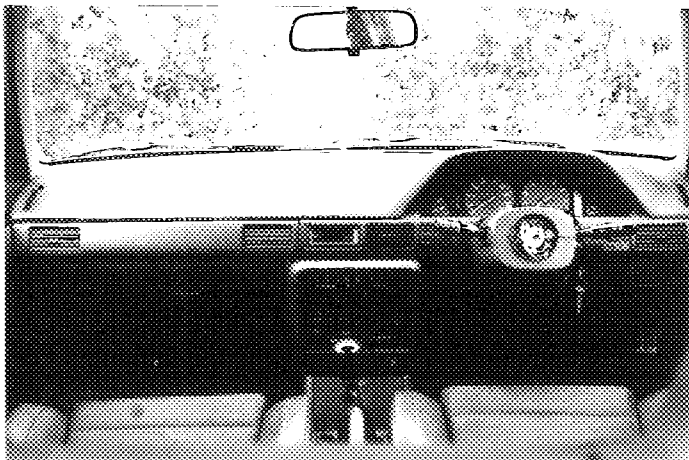

Y) Toit ouvrant  
Sunroof  
サンルーフ

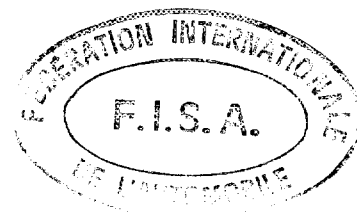
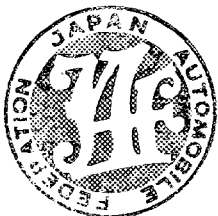
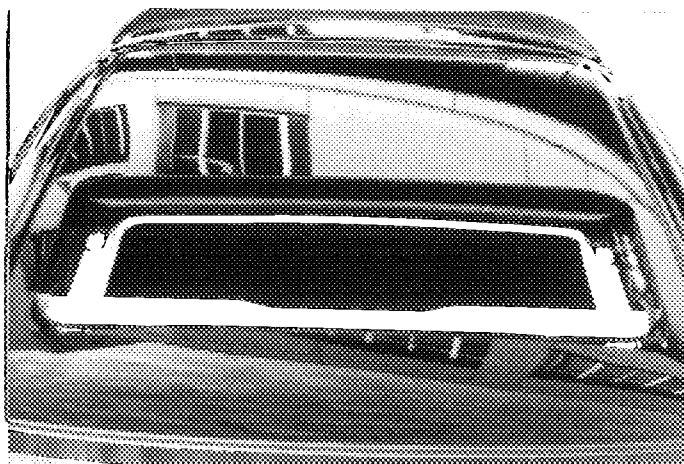

Marque  
Make  
会社名

MAZDA

Modèle  
Model  
型式

FAMILIA GT-R

FISA Homologation No

A-5473

XF公認番号 JA-151

902. Extérieur :  
Exterior :  
屋外 :

a) Nombre de portes  
Number of doors  
ドアの数

2

b) Hayon  
Tailgate  
トランク

cui	no
yes	no
有	無

c) Matériau des portières  
Door material  
ドアの材質

Avant / Front / 前	Arrière / Rear / 後
STEEL	XXXX

d) Matériau du capot avant  
Front bonnet material  
フロントの材質

STEEL

e) Matériau du capot arrière / hayon  
Rear bonnet / tailgate material  
リアのトランクの材質

STEEL / SAFETY GLASS

f) Matériau de la carrosserie  
Bodywork material  
車体の材質

STEEL, PPE, PVC, ABS, ACRYLIC RESIN, PC-PBT, PPO-AM, POLY URETHANE

h) Matériau de lunette arrière  
Rear window material  
リアの材質

SAFETY GLASS

i) Matériau des glaces de custode  
Rear quarter window material  
リアのリアウインドウの材質

XXXX

k) Matériau des vitres latérales  
Side window material  
サイドの材質

Avant / Front / 前	Arrière / Rear / 後
SAFETY GLASS	SAFETY GLASS
POLY URETHANE	POLY URETHANE

l) Matériau du pare-choc  
Material of bumper  
バンパの材質

XIII) PARTIES DE CARROSSERIE SYNTHÉTIQUES / SYNTHETIC PARTS OF THE BODY / 車体外装でプラスチックや合成樹脂等製品の箇所

ALL DARK MARKED AREAS SHOWN BELOW ARE MADE OF PLASTIC

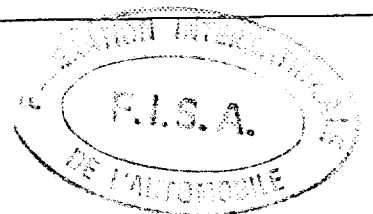
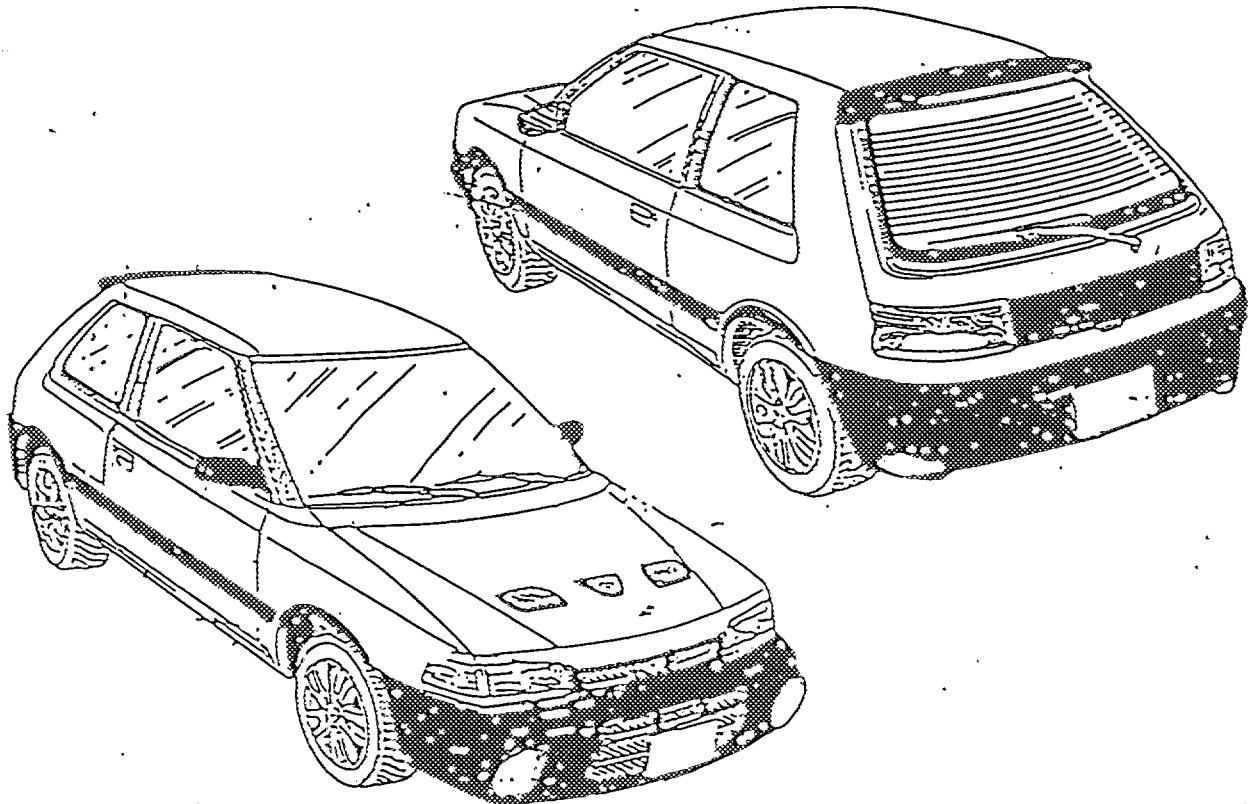

Marque  
make  
会社名

MAZDA

Modèle  
Model  
型式

FAMILIA GT-R

FISA Homologation No

A-5473

型式番号 JA-151

INFORMATIONS COMPLEMENTAIRES / COMPLEMENTARY INFORMATION / 補足情報

Art 102)

COMMERCIAL/NAME MAZDA 323 GT-R 4WD (EXCEPT JAPANESE MARKET)

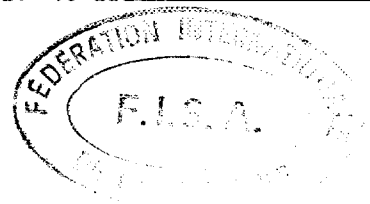
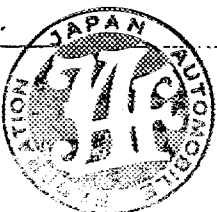



FEDERATION INTERNATIONALE  
DU SPORT AUTOMOBILE



JAPAN AUTOMOBILE FEDERATION

社団法人 日本自動車連盟

Homologation No

A-5473

Extension No.

Group A/B/T1  
Group  
グループ

JA社公認番号 JA-151

CERTIFICAT DE DIMENSIONS INTERIEURES  
CERTIFICATE FOR INTERIOR DIMENSIONS

室内寸法の証明書

Vehicule: Constructeur  
Vehicle: Manufactureur  
商標:会社名 MAZDA MOTOR CORPORATION

Modele et type  
Model and type  
型式形式 MAZDA FAMILIA GT-R 4WD (BG8)

Dimensions intérieures comme définies par le Règlement d'Homologation.  
Interior dimensions as defined by the Homologation Regulations.

全商公認機関で定義された室内寸法

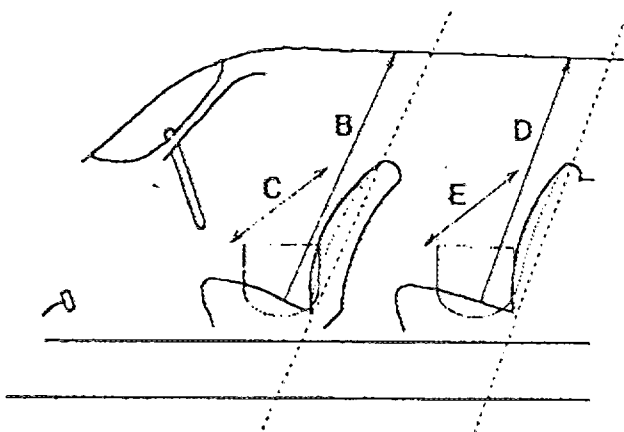

B (Hauteur sur sièges avant)  
(Height above front seats)  
(前座席上部の高さ) 1050

C (Largeur aux sièges avant)  
(Width at front seats)  
(前座席の中) 1390

D (Hauteur sur sièges arrière)  
(Height above rear seats)  
(後座席上部の高さ) 950

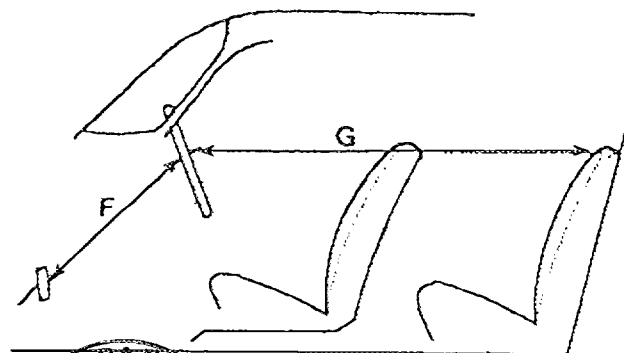

E (Largeur aux sièges arrière)  
(Width at rear seats)  
(後座席の中) 1380

F (Volant-Pédale de frein)  
(Steering wheel - brake pedal)  
(ステアリングホイール - ブレーキペダル) 605

G (Volant-paroi de séparation arrière)  
(Steering wheel - rear bulkhead)  
(ステアリングホイール - 後部バウヘッド) 1570

H = F + G =

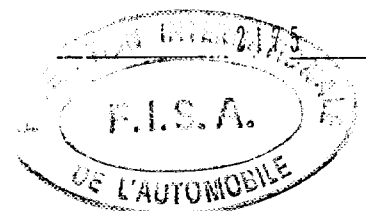
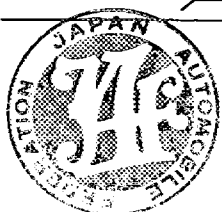

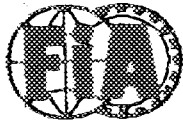

FEDERATION INTERNATIONALE  
DU SPORT AUTOMOBILE

FISA Homologation No

A-5473



JAPAN AUTOMOBILE FEDERATION

社団法人 日本自動車連盟

Groupe  
Group A/中/中+  
グループ

JAF公認番号 JA-151

JAF公認グループ

JAF発効年月日 1992年10月31日

FICHE D'HOMOLOGATION ADDITIONNELLE POUR MOTEURS SURALIMENTES PAR TURBOCOMPRESSEUR(S)  
ADDITIONAL HOMOLOGATION FORM FOR TURBO CHARGED ENGINES

ターボチャージャー付きエンジンの追加公認書式

Véhicule: Constructeur / Vehicle: Manufactureur / 車種: 製造会社 MAZDA MOTOR CORPORATION / Modèle et type / Model and type / 形式と型番 MAZDA FAMILIA GT-R 4WD (BG8)

Homologation valable à partir du / Homologation valid as from / FISA発効年月日 01 JAN. 1993

334. Suralimentation / Turbocharging / ターボチャージャー a) Marque et type du turbocompresseur / Make and type of the turbocharger / ターボチャージャーの形式と会社名 IHI (RHF6)

b) Carter de turbine: / Turbine housing: / ターボハウジング: b1) Nombre d'entrées des gaz d'échappement / Number of exhaust gas entries / 排気取り入れ口の数 1

b2) Matériau / Material / 材質 CAST-IRON

c) Roue de turbine: / Turbine wheel: / ターボホイール: c1) Matériau / Material / 材質 CAST-IRON

c2) Nombre d'aubes / Number of blades / アレードの数 11 / c3) Hauteur(s) des aubes / Height(s) of blades / アレードの高さ 24.7 ±0.5mm

c4) Cotes A,B,C, selon le schéma suivant / Dimensions A,B,C, according to the following sketch / 図2のa,b,cの寸法

A = 51.9 ±0.4mm

B = 9.4 ±0.5mm

C = 62.0 ±0.3mm

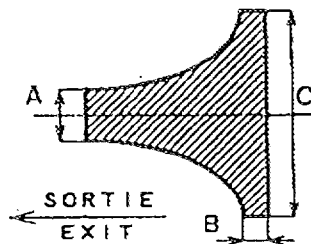

c5) Aubes variables / Variable blades / 変形アレード: 

<del>oui</del>	non
<del>yes</del>	no
<del>有</del>	無

d) Carter de compression: / Impeller housing: / インペラハウジング: d1) Nombre d'entrées d'air(mélange) / Number of air entries(gas) / 空気を取り入れ口の数 1

d2) Matériau / Material / 材質 ALUMINUM ALLOY

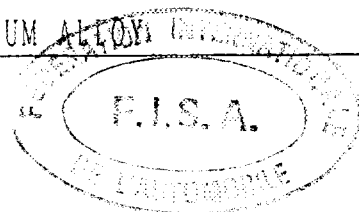

Marque / Make / 会社名: MAZDA

Modèle / Model / 型式: FAMILIA GT-R

FISA Homologation No

A-5473

JAF公認番号 JA-151

e) Roue de compression: Impeller wheel: 圧縮ローター

e1) Matériau / Material: ALUMINUM ALLOY

e2) Nombre d'aubes / Number of blades: 10

e3) Hauteur(s) des aubes / Height(s) of blades: 21.6, 15.7 ±0.5mm

e4) Cotes A,B,C, selon le schéma suivant / Dimensions A,B,C, according to the following sketch

A = 49.2 ±0.4mm

B = 5.1 ±0.5mm

C = 65.0 ±0.4mm

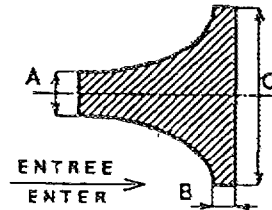

e5) Aubes variables / Variable blades: 変形ローター

<input checked="" type="checkbox"/> oui	<input type="checkbox"/> non
<input checked="" type="checkbox"/> yes	<input type="checkbox"/> no
<input checked="" type="checkbox"/>	<input type="checkbox"/>

f) Régulation de la pression: Pressure regulation: 圧力調整

f1) Type de régulation de la pression: Type of pressure adjustment: 圧力調整の形式

by-pass bypass バイパス

soupape de décharge relief valve リリーフバルブ

autre cas other case その他

f2) Type de la soupape / Type of the valve: バルブの形式

SWING VALVE, WASTEGATE, ACTUATOR

g) Système d'échappement: Exhaust system: 排気方式

g1) Dimensions intérieures de(s) éventuel(s) tuyau(x) d'échappement entre collecteur d'échappement et turbocompresseur

Internal dimensions of the possible exhaust pipe(s) between exhaust manifold and turbocharger

ターボチャージャーとマニホールドの間の排気パイプの内寸法

XXXXX ±2mm

h) Refroidissement de l'air d'admission: Cooling of intake air: 吸気冷却

h2) Système / System:  air/air 空気/空気

air/eau 空気/水

simple-passe 単流

double-passe 双流

h3) Diamètre de l'entrée d'air / Air inlet diameter: 吸気口径

Capacité en eau / Water capacity: 水の容量 XXXXX ℓ

m) Diamètre de la sortie d'air / Air outlet diameter: 排気口径

50 ±2mm

56 ±2mm

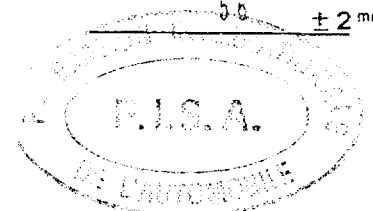

Marque  
Make  
会社名

MAZDA

Modèle  
Model  
型式

FAMILIA GT-R

FISA Homologation No

A-5473

公認番号 JA-151

K) Vue de dessus du turbocompresseur  
Plan view of turbocharger  
ターボチャージャーの上面図

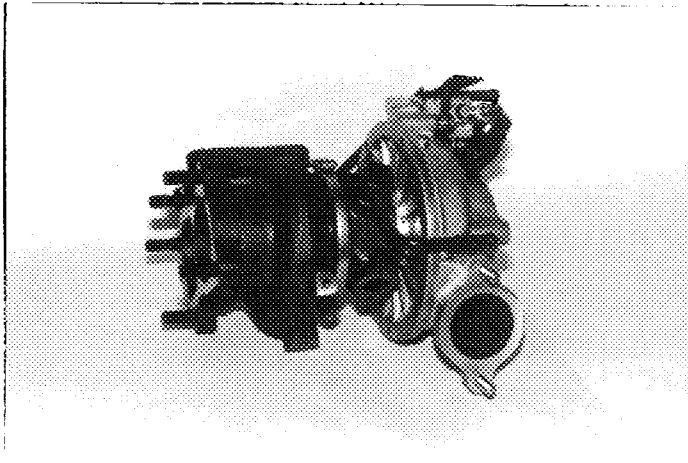

L) Vue de face du turbocompresseur  
Front view of turbocharger  
ターボチャージャーの前面図

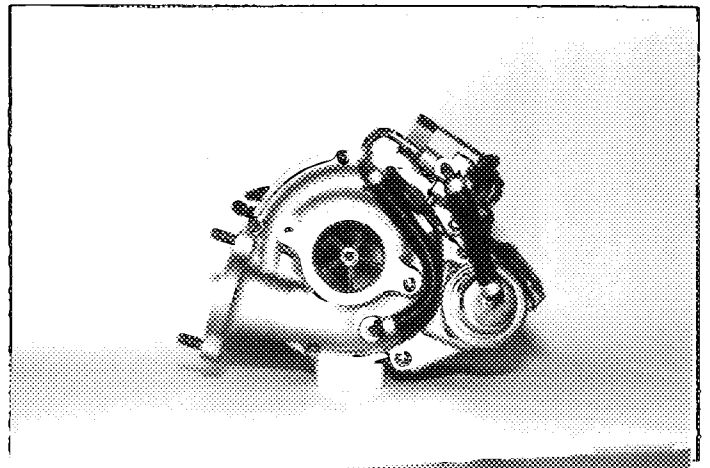

M) Vue côté du turbocompresseur  
Side view of turbocharger  
ターボチャージャーの側面図

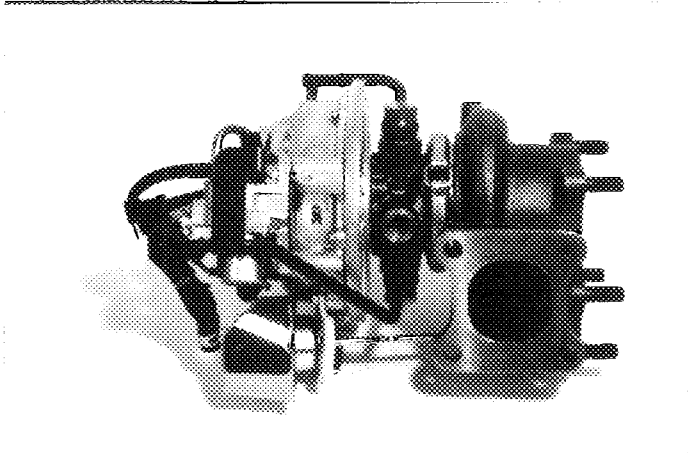

N) Carter de turbine du turbocompresseur  
Turbine housing of turbocharger  
ターボチャージャーのタービンハウジング

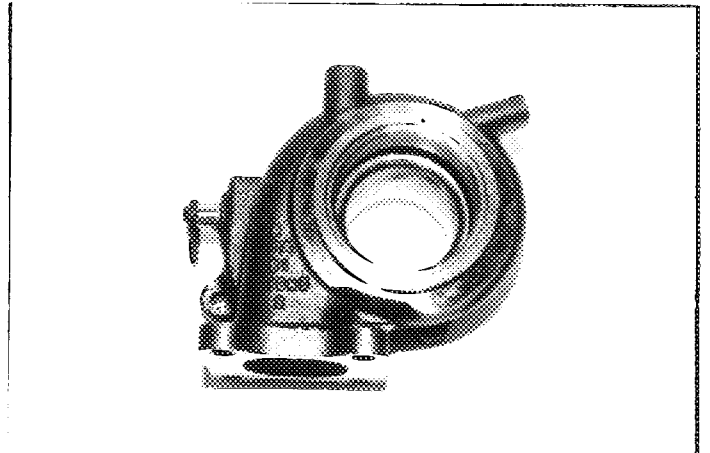

O) Soupape et montage du by-pass du turbocompresseur  
Valve and by-pass installation of turbocharger

0167と0141のターボチャージャーへの取付位置

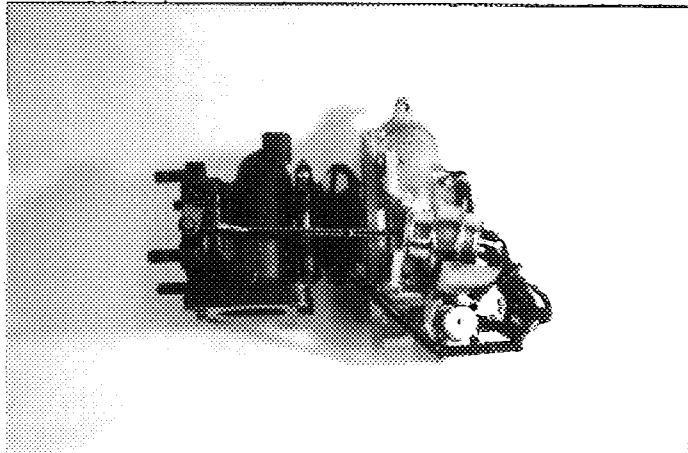

P) Système d'échappement entre collecteur et turbocompresseur  
Exhaust system between manifold and turbocharger  
ターボチャージャーとエンジン間の排気方式

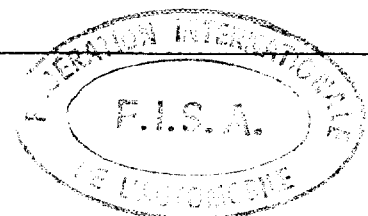
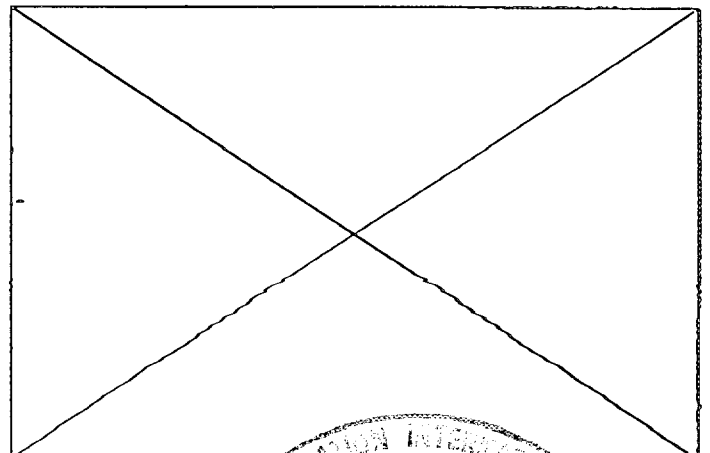



Marque  
Make  
会社名

MAZDA

Modèle  
Model  
型式

FAMILIA GT-R

FISA Homologation No

A-5473

JA-151

Q) Carter de compresseur du turbocompresseur  
Compressor housing of turbocharger  
ターボチャージャーのコンプレッサーハウジング

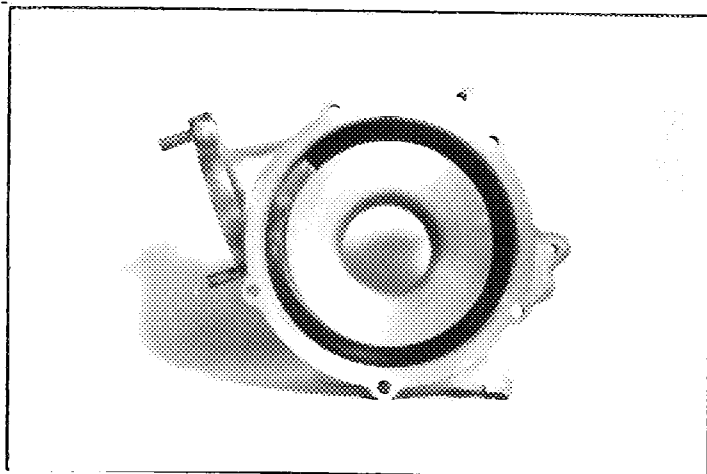

R) Echangeur intermédiaire déposé  
Intercooler dismounted  
取り外したインタークーラー

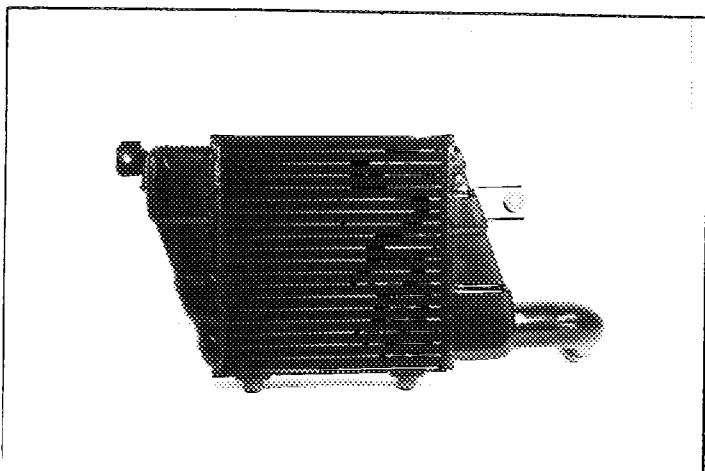

Z) Echangeur intermédiaire monté  
Intercooler mounted  
取り付けしたインタークーラー

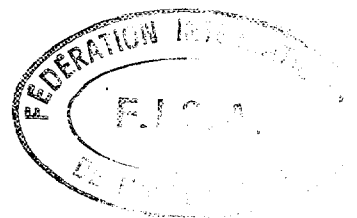
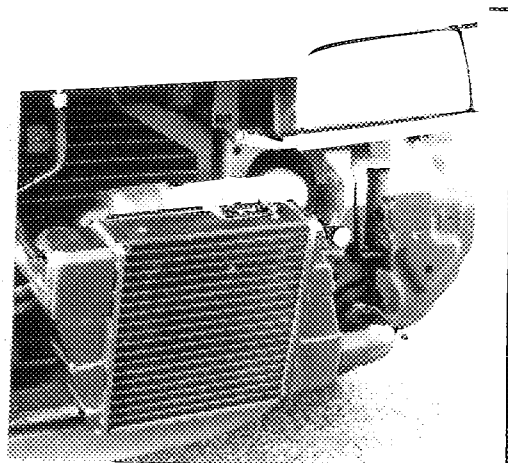

Marque  
Make  
会社名

MAZDA

Modèle  
Model  
型式

FAMILIA GT-R

FISA Homologation No

A-5473

JA-151

V) Entrée des gaz d'échappement dans turbine de compresseur  
Exhaust gas inlet to the compressor turbine  
ターボコンプレッサの排気入口図

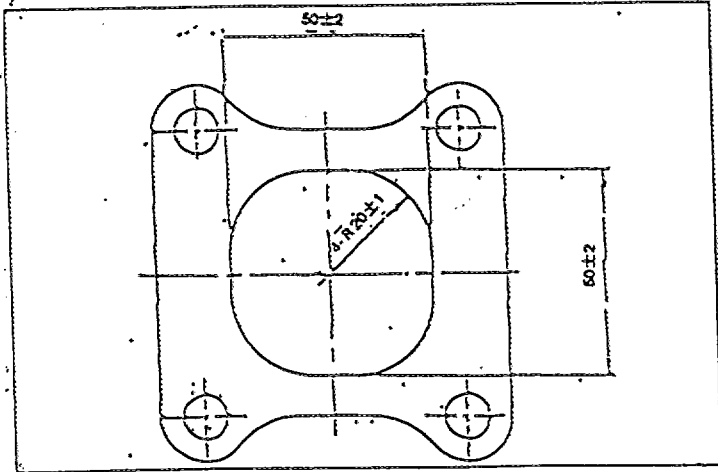

VI) Sortie des gaz d'échappement de turbine de compresseur  
Exhaust gas outlet from the compressor turbine  
ターボコンプレッサの排気出口図

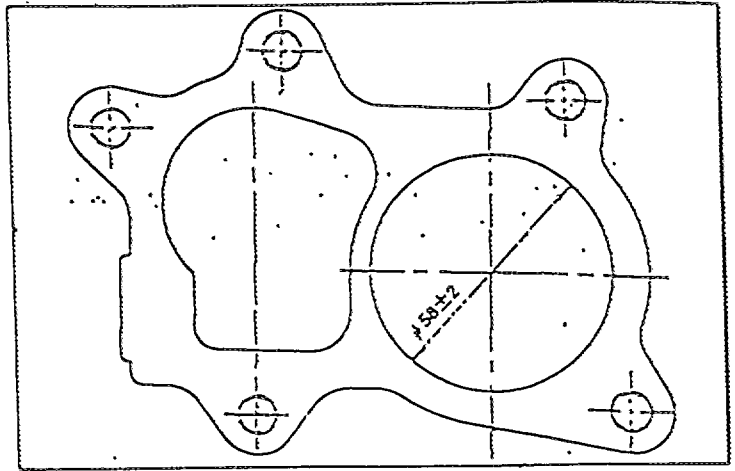

VII) Entrée d'air(mélange) dans carter de compresseur  
Air(gas) inlet to the compressor housing  
コンプレッサハウジングの入口図

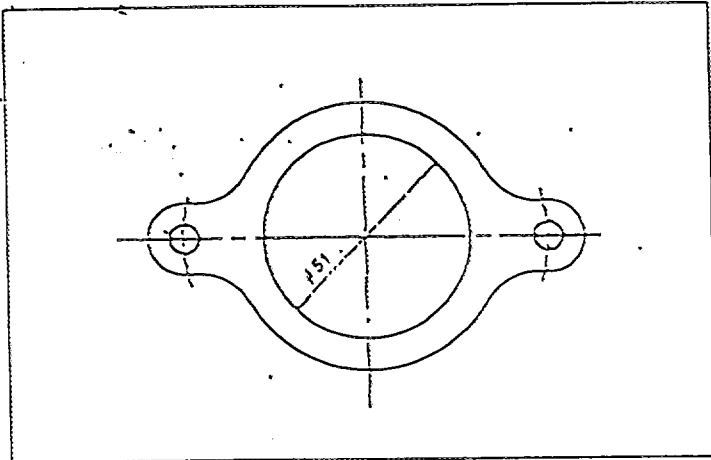

VIII) Sortie d'air(mélange) du carter de compresseur  
Air(gas) outlet from the compressor housing  
コンプレッサハウジングからの出口図

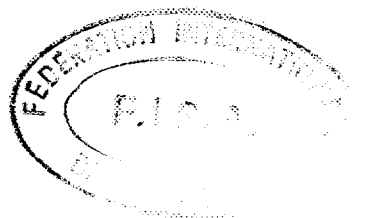
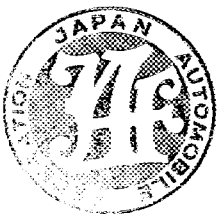
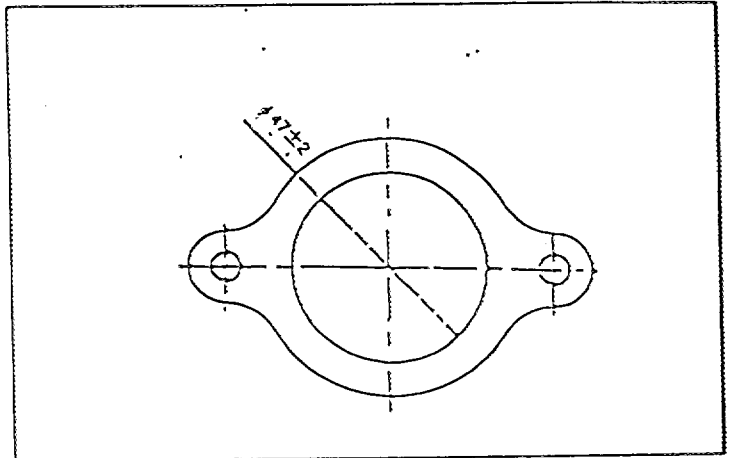

Marque  
Make  
会社名

MAZDA

Modèle  
Model  
型式

FAMILIA GT-R

FISA Homologation No

A-5473

検査番号 JA-151

IX) Dispositif réglant la pression de suralimentation  
Device regulating the turbocharging pressure  
過給圧力の調整装置図

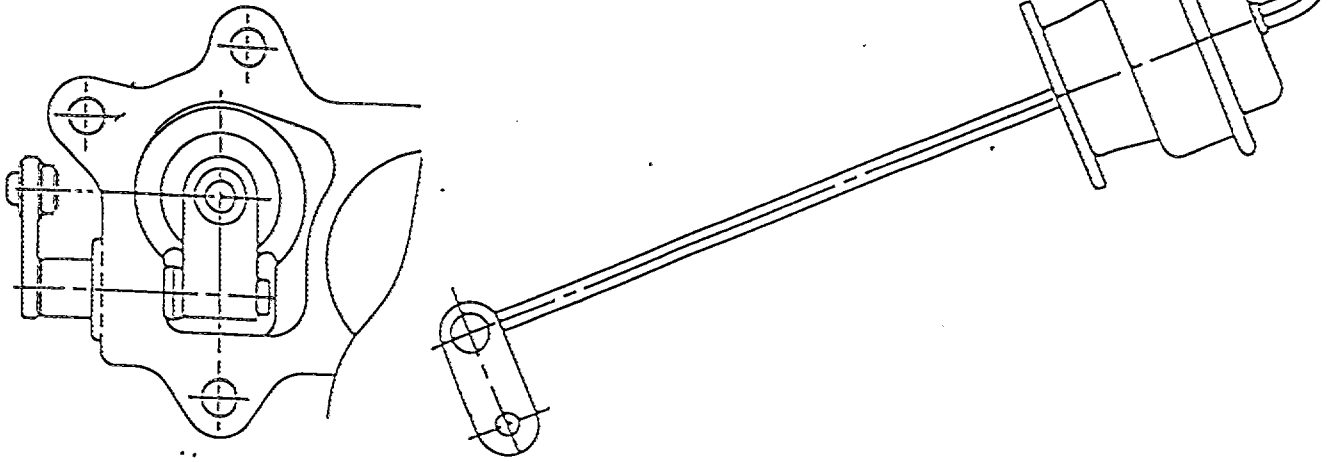

Pression standard  
Standard pressure  $0.8 \pm 0.1$  bar  
標準過給圧力

Procédure de contrôle de la pression  
Procedure for checking the pressure  
過給圧力の検査手順

PRESSURE CORRESPONDING TO A LONGITUDINAL DISPLACEMENT OF THE WASTEGATE

ACTUATING ROD OF 2mm

XV) Système de refroidissement de l'intercooler  
Intercooler cooling system  
インタークーラの冷却方式図

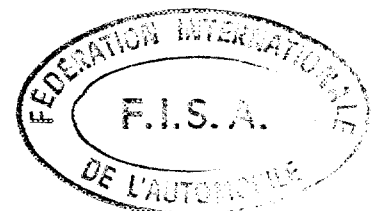
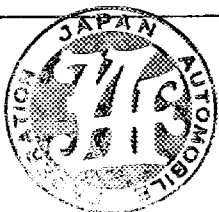
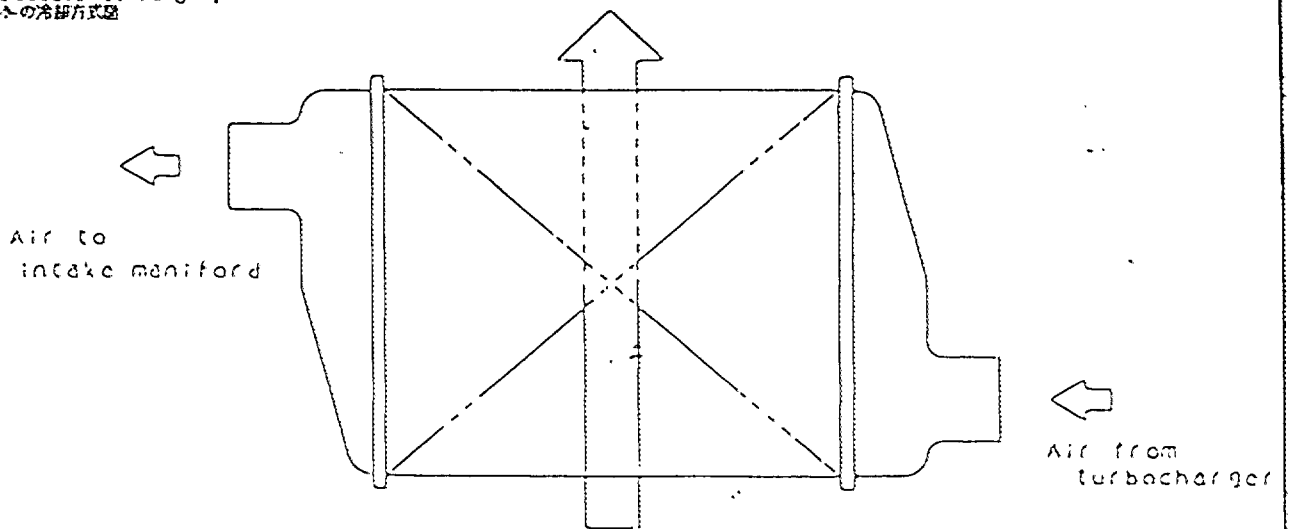



FEDERATION INTERNATIONALE  
DU SPORT AUTOMOBILE

Homologation No

**A-5473**



JAPAN AUTOMOBILE FEDERATION  
社団法人 日本自動車連盟

Extension No

**01/01V0**

FORM OF EXTENSION TO THE OFFICIAL FISA HOMOLOGATION

FISA公認追加書式

JAF公認番号

JAF発行年月日

VO Option variant / オプション変更

Homologation valid as from

FISA発行年月日

**01 JAN. 1993**

in group

FISA公認グループ

**A**

Manufacturer of the car

車両製造者

**MAZDA MOTOR CORPORATION**

Model and type

形式とモデル

**FAMILIA GT-R**

~~ROLLBAR~~ / ROLL CAGE

~~ロールバー~~ / ロールケージ

Main rollbar

主ロールバー

Longitudinal / diagonal strut

前後 / 斜ストラット

Front rollbar

前ロールバー

Rollbar manufacturer

ロールバー製造者

**HEIGO-AUTOTECHNIK GMBH**

Material

材質

**STEEL (EST460)**

**STEEL (EST460) / STEEL (EST460)**

**STEEL (EST460)**

Exterior diameter

外径

**38** mm

**38** mm / **38** mm

**38** mm

Wall thickness

肉厚

**2.5** mm

**1.2** mm / **1.2** mm

**2.5** mm

Elastic limit

弾性限界

**48** kg/mm<sup>2</sup>

**48** kg/mm<sup>2</sup> / **48** kg/mm<sup>2</sup>

**48** kg/mm<sup>2</sup>

Tensile strength

引張強度

**70** kg/mm<sup>2</sup>

**70** kg/mm<sup>2</sup> / **70** kg/mm<sup>2</sup>

**70** kg/mm<sup>2</sup>

Total weight including fixings

取付金具を含む重量

**31** kg

Complete rollbar / roll cage outside the car

完成したロールバー / 車から外したロールケージ

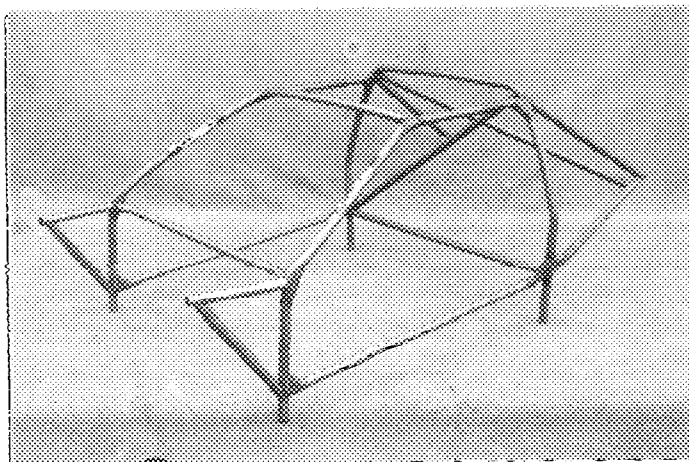

We certify that the present rollbar / rollcage complies with the conditions of the FIA Appendix J, in particular with regard to its attachments, its connections and its stress resistances.

上記ロールバー/ロールケージは、特に取付け部分、取付手、強度に同じ FIA 国際スポーツ連盟付録 J の条件に準拠していることを証明いたします。

Signature of the car manufacturer representative.

車両製造者代表者の署名

**HIROSHI YAMAMOTO**  
DEPUTY GENERAL MANAGER  
PRODUCT PLANNING & DEVELOPMENT DIV.  
MAZDA MOTOR CORPORATION

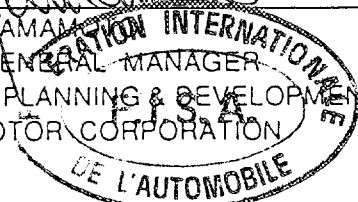

Make MAZDA Model FAMILIA GT-R No Homol. A-5473  
会社名 型式

PHOTOS OR DRAWINGS OF THE ATTACHMENTS ON THE BODY:  
車体取付部の写真または図解

No Ext. 01/01V0

JAF公認番号 JA-151 VO- 1/1

FRONT HOOP TO FLOOR

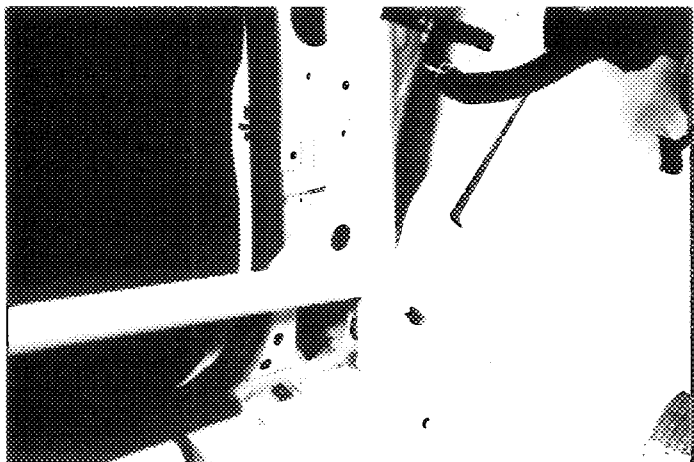

FRONT HOOP TO ROOF AND PILLAR

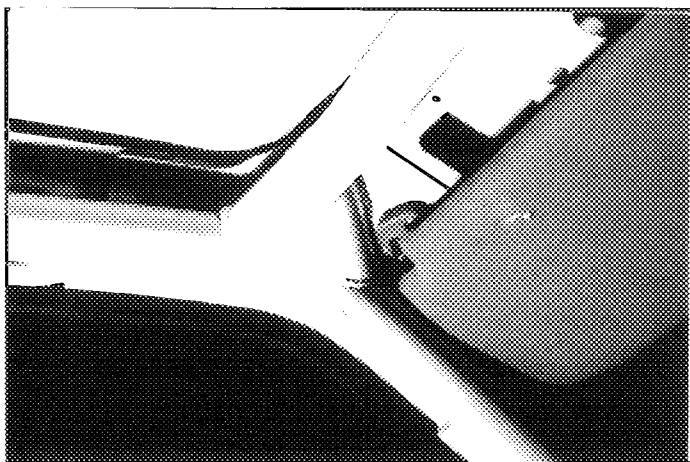

FRONT HOOP TO ROOF

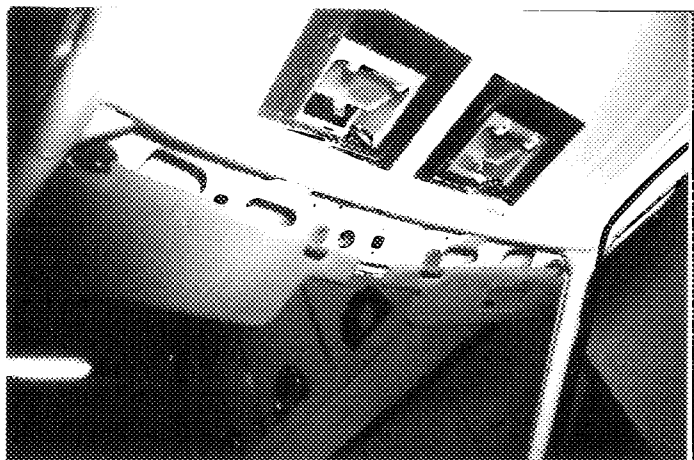

MAIN HOOP TO FLOOR

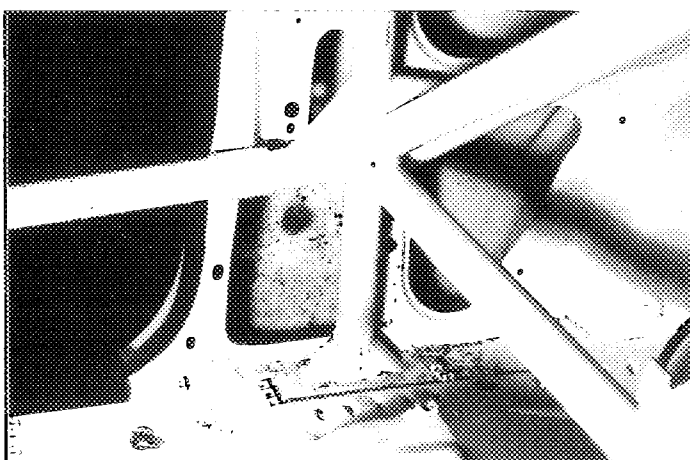

MAIN HOOP TO CENTER PILLAR

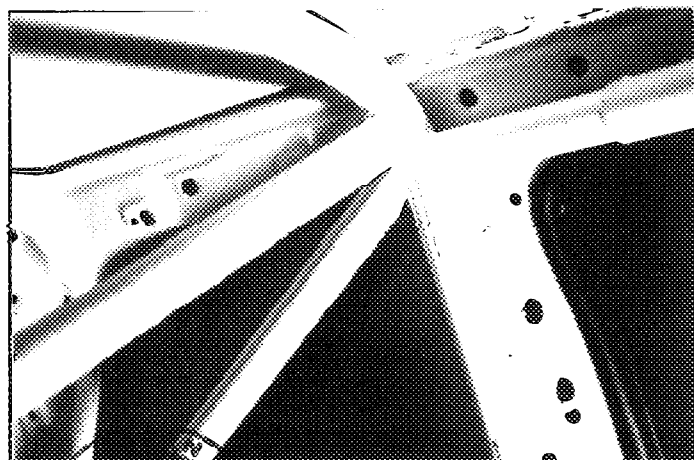

LONGITUDINAL STRUT TO REAR STRUT TOWER

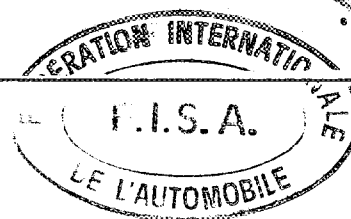

Make  
会社名 MAZDA

Model  
型式 FAMILIA GT-R

No Homol. A-5473

PHOTOS OR DRAWINGS OF THE ATTACHMENTS ON THE BODY:  
車体取付部の写真または図解

No Ext. 01/01V0

JAF公認番号 JA-151 VO- 1/1

FRONT REINFORCEMENT TO BULKHEAD

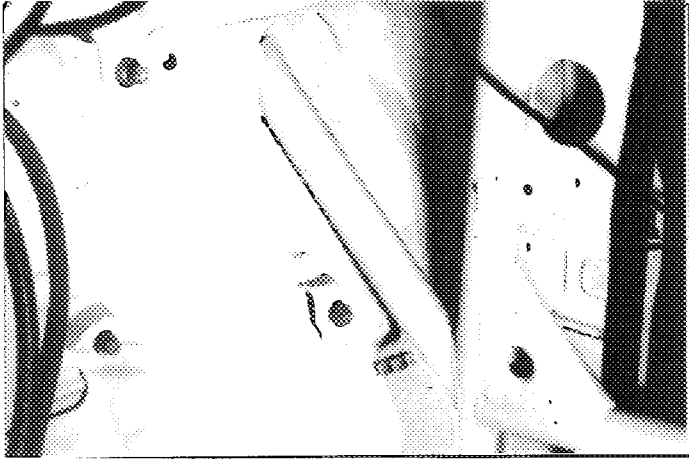

FRONT REINFORCEMENT TO FRONT STRUT TOWER

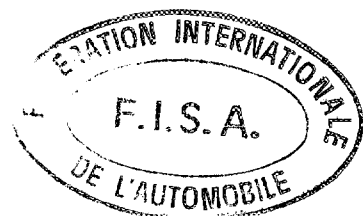
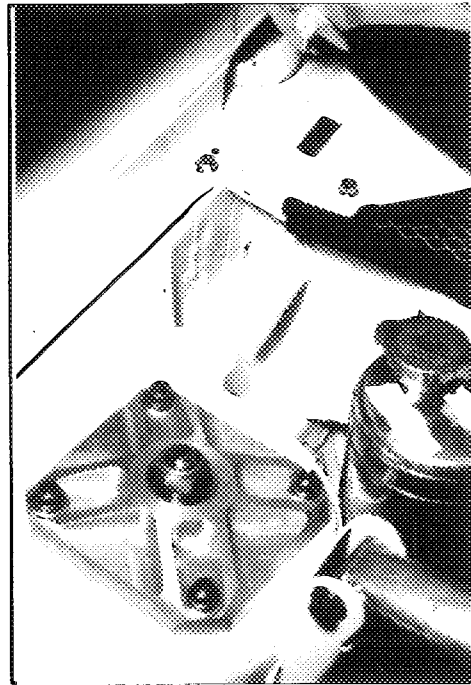



FEDERATION INTERNATIONALE  
DU SPORT AUTOMOBILE  
JAPAN AUTOMOBILE FEDERATION  
社団法人 日本自動車連盟

FISA Homologation No

A-5473

Extension No

02/02V0

JAF公認番号 \_\_\_\_\_

発効年月日 \_\_\_\_\_

FORM OF EXTENSION TO THE OFFICIAL FISA HOMOLOGATION  
FISA公認追加書式

- ES Sporting evolution of the type / スポーツ進化
- ET Normal evolution of the type / 形式の正常進化
- VF Supply variant / 供給変型
- VO Option variant / オプション変型
- ER Erratum / 誤記訂正

Homologation valid as from  
公認発行日 \_\_\_\_\_

01 JAN 1993

in group

FISAグループ \_\_\_\_\_

A

Manufacturer

製造者 MAZDA MOTOR CORPORATION

Model and type

型式と形式 MAZDA FAMILIA GT-R 4WD (BG8)

Page or ext. ページまたは補足	Art. 項目	Description 記述																																
13	6 603	<p><u>DRIVE</u></p> <p>GEARBOX 1ST ADDITIONAL GEARBOX e) RATIO</p> <table border="1"> <thead> <tr> <th></th> <th>RATIO</th> <th>NUMBER OF TEETH</th> <th>SYNCHRO</th> </tr> </thead> <tbody> <tr> <td>1</td> <td>3.000</td> <td>36/12</td> <td></td> </tr> <tr> <td>2</td> <td>2.267</td> <td>34/15</td> <td></td> </tr> <tr> <td>3</td> <td>1.821</td> <td>31/17</td> <td></td> </tr> <tr> <td>4</td> <td>1.526</td> <td>29/19</td> <td></td> </tr> <tr> <td>5</td> <td>1.333</td> <td>28/21</td> <td></td> </tr> <tr> <td>6</td> <td>1.182</td> <td>26/22</td> <td></td> </tr> <tr> <td>R</td> <td>3.000</td> <td><math>\frac{12}{16} \times \frac{16}{11}</math></td> <td></td> </tr> </tbody> </table> <p>f) GEAR CHANGE GATE</p> <p>1ST ADDITIONAL GEARBOX CASING AND TRANSFER GEAR CASING</p>		RATIO	NUMBER OF TEETH	SYNCHRO	1	3.000	36/12		2	2.267	34/15		3	1.821	31/17		4	1.526	29/19		5	1.333	28/21		6	1.182	26/22		R	3.000	$\frac{12}{16} \times \frac{16}{11}$	
	RATIO	NUMBER OF TEETH	SYNCHRO																															
1	3.000	36/12																																
2	2.267	34/15																																
3	1.821	31/17																																
4	1.526	29/19																																
5	1.333	28/21																																
6	1.182	26/22																																
R	3.000	$\frac{12}{16} \times \frac{16}{11}$																																



90-01

Page 1

Make  
会社名

MAZDA

Model  
型式

FAMILIA GT-R

No Homol.

A-5473

No Ext.

02/02V0

JAF公認番号 JA-151 VO- 2/2

Page or ext. ページまたは補足	Art. 項目	Description 記述
13	603	GEAR SHIFTING MECHANISM FOR ADDITIONAL GEARBOX PHOTO 93-02
	603	ALTERNATIVE GEAR SHIFTING MECHANISM FOR ADDITIONAL GEARBOX PHOTO 93-03
		*NEW POSITION OF HOLE IN BULKHEAD FOR THE PASSAGE OF THE GEAR SHIFTING MECHANISM. PHOTO 93-04

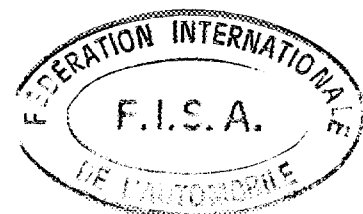



Make  
会社名

MAZDA

Model  
型式

FAMILIA GT-R

No Homol.

A-5473

No Ext.

02/02VO

JAF公認番号 JA-151 VO- 2/2

Page or ext. ページまたは補足	Art. 項目	Description 記述																																																																																																																
13	603	<p>2ND ADDITIONAL GEARBOX (RATIO)</p> <p>e) RATIO</p> <table border="1"> <thead> <tr> <th></th> <th>RATIO</th> <th>NUMBER OF TEETH</th> <th>SYNCHRO</th> </tr> </thead> <tbody> <tr> <td>1</td> <td>3.692</td> <td>48/13</td> <td></td> </tr> <tr> <td>2</td> <td>2.800</td> <td>42/15</td> <td></td> </tr> <tr> <td>3</td> <td>2.167</td> <td>39/18</td> <td></td> </tr> <tr> <td>4</td> <td>1.714</td> <td>36/21</td> <td></td> </tr> <tr> <td>5</td> <td>1.409</td> <td>31/22</td> <td></td> </tr> <tr> <td>6</td> <td>1.178</td> <td>33/28</td> <td></td> </tr> <tr> <td>R</td> <td>3.000</td> <td><math>\frac{42}{16} \times \frac{16}{14}</math></td> <td></td> </tr> </tbody> </table> <p>(f) GEAR CHANGE GATE</p> <p>*SAME GEARBOX CASING AND TRANSFER GEAR CASING AS 1ST ADDITIONAL GEARBOX</p> <p>605 FINAL DRIVE</p> <table border="1"> <thead> <tr> <th></th> <th colspan="2">FRONT</th> <th colspan="2">REAR</th> </tr> <tr> <th>a) TYPE</th> <th colspan="2">SPUR GEAR</th> <th colspan="2">HYPOID GEAR</th> </tr> <tr> <th>b) RATIO &amp; c) TEETH NUMBER</th> <th>RATIO</th> <th>TEETH NUMBER</th> <th>RATIO</th> <th>TEETH NUMBER</th> </tr> </thead> <tbody> <tr> <td></td> <td>4.545</td> <td>50/11</td> <td>3.909</td> <td>43/11</td> </tr> <tr> <td></td> <td>4.167</td> <td>50/12</td> <td>3.900</td> <td>39/10</td> </tr> <tr> <td></td> <td>4.083</td> <td>49/12</td> <td>3.889</td> <td>35/9</td> </tr> <tr> <td></td> <td>4.071</td> <td>57/14</td> <td>3.556</td> <td>32/9</td> </tr> <tr> <td></td> <td>3.769</td> <td>49/13</td> <td></td> <td></td> </tr> <tr> <td></td> <td>3.750</td> <td>45/12</td> <td></td> <td></td> </tr> <tr> <td></td> <td>3.733</td> <td>56/15</td> <td></td> <td></td> </tr> <tr> <td></td> <td>3.692</td> <td>48/13</td> <td></td> <td></td> </tr> <tr> <td></td> <td>3.438</td> <td>55/16</td> <td></td> <td></td> </tr> <tr> <td></td> <td>3.429</td> <td>48/14</td> <td></td> <td></td> </tr> <tr> <td></td> <td>3.357</td> <td>47/14</td> <td></td> <td></td> </tr> <tr> <td></td> <td>3.176</td> <td>54/17</td> <td></td> <td></td> </tr> <tr> <td></td> <td>2.944</td> <td>53/18</td> <td></td> <td></td> </tr> </tbody> </table>		RATIO	NUMBER OF TEETH	SYNCHRO	1	3.692	48/13		2	2.800	42/15		3	2.167	39/18		4	1.714	36/21		5	1.409	31/22		6	1.178	33/28		R	3.000	$\frac{42}{16} \times \frac{16}{14}$			FRONT		REAR		a) TYPE	SPUR GEAR		HYPOID GEAR		b) RATIO & c) TEETH NUMBER	RATIO	TEETH NUMBER	RATIO	TEETH NUMBER		4.545	50/11	3.909	43/11		4.167	50/12	3.900	39/10		4.083	49/12	3.889	35/9		4.071	57/14	3.556	32/9		3.769	49/13				3.750	45/12				3.733	56/15				3.692	48/13				3.438	55/16				3.429	48/14				3.357	47/14				3.176	54/17				2.944	53/18		
	RATIO	NUMBER OF TEETH	SYNCHRO																																																																																																															
1	3.692	48/13																																																																																																																
2	2.800	42/15																																																																																																																
3	2.167	39/18																																																																																																																
4	1.714	36/21																																																																																																																
5	1.409	31/22																																																																																																																
6	1.178	33/28																																																																																																																
R	3.000	$\frac{42}{16} \times \frac{16}{14}$																																																																																																																
	FRONT		REAR																																																																																																															
a) TYPE	SPUR GEAR		HYPOID GEAR																																																																																																															
b) RATIO & c) TEETH NUMBER	RATIO	TEETH NUMBER	RATIO	TEETH NUMBER																																																																																																														
	4.545	50/11	3.909	43/11																																																																																																														
	4.167	50/12	3.900	39/10																																																																																																														
	4.083	49/12	3.889	35/9																																																																																																														
	4.071	57/14	3.556	32/9																																																																																																														
	3.769	49/13																																																																																																																
	3.750	45/12																																																																																																																
	3.733	56/15																																																																																																																
	3.692	48/13																																																																																																																
	3.438	55/16																																																																																																																
	3.429	48/14																																																																																																																
	3.357	47/14																																																																																																																
	3.176	54/17																																																																																																																
	2.944	53/18																																																																																																																



Make  
会社名

MAZDA

Model  
型式

FAMILIA GT-R

No Homol. A-5473

No Ext. 02/02V0

JAF公認番号 JA-151 VO- 2/2

Page or ext. ページまたは補足	Art. 項目	Description 記述
14	605	e) RATIO OF THE TRANSFER BOX 43/11×11/43 39/10×10/39 35/ 9× 9/35 32/ 9× 9/32
	605	REINFORCED DIFFERENTIAL CASING : TYPE A PHOTO 93-05 TYPE B PHOTO 93-06 TYPE C PHOTO 93-07
	606	REINFORCED FRONT DRIVE SHAFT : TYPE A PHOTO 93-08 TYPE B PHOTO 93-09
	606	REINFORCED REAR DRIVE SHAFT : TYPE A PHOTO 93-10 TYPE B PHOTO 93-11 TYPE C PHOTO 93-12
	606	OUTPUT FLANGE FOR REAR DRIVE SHAFT PHOTO 93-13
	606	SPACER FOR DRIVE SHAFT (FRONT/ REAR) PHOTO 93-14 *THICKNESS FROM 3mm TO 25mm
	606	REINFORCED PROPELLER SHAFT PHOTO 93-15

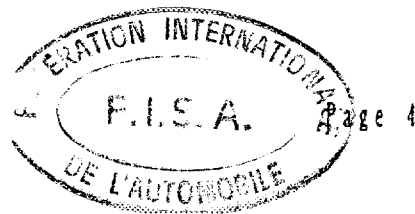

Make  
会社名

MAZDA

Model  
型式

FAMILIA GT-R

No Homol.

A-5473

No Ext.

02/02VO

JAF公認番号

JA-151VO-2/?

Page or ext. ページまたは補足	Art. 項目	Description 記述
15	7	<u>SUSPENSION</u>
	701	REINFORCED FRONT KNUCKLE TYPE A PHOTO 93-16 TYPE B PHOTO 93-17 TYPE C PHOTO 93-18
	701	REINFORCED REAR KNUCKLE TYPE A PHOTO 93-19 TYPE B PHOTO 93-20
	701	STEERING ARM FOR REINFORCED KNUCKLE TYPE A PHOTO 93-21 TYPE B TYPE C TYPE D PHOTO 93-22 *STEERING RATIO WILL CHANGE AS STATIC RIDE HEIGHT IS VARIED ON ADJUSTABLE STRUTS
	701	FRONT LOWER ARM BOTTOM MOUNTING PLATE ON REINFORCED FRONT KNUCKLE PHOTO 93-23
	701	ADJUSTABLE TIE ROD TYPE A PHOTO 93-24 TYPE B PHOTO 93-25
	701	HEAVY DUTY WHEEL HUB (FRONT / REAR) TYPE A PHOTO 93-26 TYPE B PHOTO 93-27
	701	REINFORCED FRONT LOWER ARM TYPE A PHOTO 93-28 TYPE B PHOTO 93-29 TYPE C PHOTO 93-30
	701	REINFORCED REAR FIXATION FRONT LOWER ARM TYPE A AND TYPE B PHOTO 93-31



Make  
会社名

MAZDA

Model  
型式

FAMILIA GT-R

No Homol.

A-5473

No Ext.

02/02VO

JAF公認番号 JA-151 VO- 2/2

Page or ext. ページまたは補足.	Art. 項目	Description 記述
15	701	REINFORCED SUSPENSION TOP MOUNTING (FRONT/REAR) * TYPE A PHOTO 93-32 TYPE B PHOTO 93-33 TYPE C PHOTO 93-34 TYPE D PHOTO 93-35 TYPE E PHOTO 93-36 *THE ANCHORAGE POINTS COMPLY WITH FISA HOMOLOGATION REGULATIONS
	7	REINFORCED FRONT SUBFRAME* PHOTO 93-37 REINFORCED FRONT SUBFRAME* PHOTO 93-38 REINFORCED FRONT SUBFRAME* PHOTO 93-39 REINFORCED FRONT SUBFRAME* PHOTO 93-40 ALTERNATIVE FRONT SUBFRAME* PHOTO 93-41 ALTERNATIVE FRONT SUBFRAME* PHOTO 93-42 ALTERNATIVE FRONT SUBFRAME* PHOTO 93-43 * - INTERCHANGEABLE WITH ORIGINAL PARTS. * - SUSPENSION ATTACHMENT POINTS COMPLY WITH FISATHE HOMOLOGATION REGULATIONS

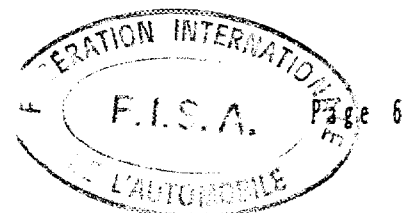

Make Model No Homol. A - 5473  
 会社名 MAZDA 型式 FAMILIA GT-R

No Ext. 02/02VO

JAF公認番号 JA-151 VO- 2/2

Page or ext. ページまたは補足	Art. 項目	Description 記述	
15	701	REINFORCED REAR SUSPENSION WITH ADJUSTABLE BEARINGS · TRAILING LINK · LATERAL LINK (FRONT) · LATERAL LINK (REAR)	PHOTO 93-44
	7	REINFORCED REAR SUBFRAME*	PHOTO 93-45
		REINFORCED REAR SUBFRAME*	PHOTO 93-46
		ALTERNATIVE REAR SUBFRAME* * · THE REINFORCED REAR SUBFRAMES ARE INTERCHANGEABLE WITH THE ORIGINAL PART. · SUSPENSION ATTACHMENT POINTS COMPLY WITH FISA HOMOLOGATION REGULATIONS	PHOTO 93-47
	706	SEPARATE FRONT ANTI-ROLL BAR (MOUNTING POSITION CHANGED REPLACE EXISTING PARTS) *MAIN BAR DIAMETER FROM 20mm TO 35mm (SOLID OR TUBULAR)	PHOTO 93-48
	706	SEPARATE REAR ANTI-ROLL BAR (MOUNTING POSITION CHANGED REPLACE EXISTING PARTS) *MAIN BAR DIAMETER FROM 12mm TO 26mm (SOLID OR TUBULAR)	PHOTO 93-49
	706	ALTERNATIVE SEPARATE REAR ANTI-ROLL BAR WITH VARIABLE RATE LEVER ARMS, ( MOUNTING POSITION CHANGED REPLACE EXISTING PARTS) *MAIN BAR DIAMETER FROM 12mm TO 26mm (SOLID OR TUBULAR)	PHOTO 93-50



Make MAZDA Model FAMILIA GT-R No Homol. A-5473  
 会社名 MAZDA 型式 FAMILIA GT-R No Ext. 02/02V0  
 JAF公認番号 JA-151 VO- 2/2

Page or ext. ページまたは補足	Art. 項目	Description 記述
15	707	REINFORCED STRUT/ DAMPER UNIT WITH ADJUSTABLE SPRING SEAT (FRONT/REAR)  TYPE A PHOTO 93-51 TYPE B PHOTO 93-52 TYPE C PHOTO 93-53 TYPE D PHOTO 93-54 TYPE E PHOTO 93-55 TYPE F PHOTO 93-56 TYPE G PHOTO 93-57 TYPE H PHOTO 93-58
	7 8	KIT WATER COOLING FOR BRAKES OR FOR SHOCK ABSORBERS CONSISTING OF WATER JETS, PUMPS, SWITCH, RELAY, FEED HOSES AND RESERVOIR (CAPACITY: 4L ± 0.5L) PHOTO 93-59
	7 8	ALTERNATIVE KIT WATER COOLING FOR BRAKES OR FOR SHOCK ABSORBERS CONSISTING OF WATER JETS, PUMPS, SWITCH, RELAY, FEED HOSES AND RESERVOIR (CAPACITY: 4L ± 0.5L) PHOTO 93-60 *THIS SYSTEM CAN BE USED WITHOUT PUMP UNDER AIR PRESSURE

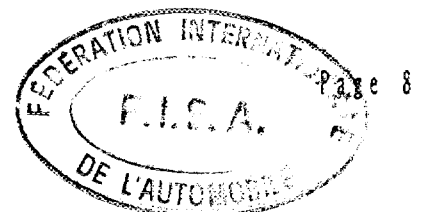

Make 会社名 MAZDA Model 型式 FAMILIA GT-R No Homol. A-5473  
 No Ext. 02/02VO  
 JAF公認番号 JA-151VO-2/2

Page or ext. ページまたは補足	Art. 項目	Description 記述
16, 17	8	<u>RUNNING GEAR:</u>
	801	WHEEL SPACER, THICKNESS FROM 3mm TO 10mm PHOTO 93-61
	801	DIRT REMOVAL SCOOP FOR FRONT AND OR REAR WHEEL TYPE A PHOTO 93-63 TYPE B PHOTO 93-64
	803	ALTERNATIVE DUAL CYLINDER BRAKE PEDAL BOX, ADJUSTABLE FROM THE COCKPIT AND HYDRAULIC CYLINDER FOR CLUTCH TYPE A PHOTO 93-65 TYPE B PHOTO 93-66
	803	ALTERNATIVE BRAKE/CLUTCH MASTER CYLINDER (CYLINDER SIZE FROM 12.7mm TO 25.4mm) TYPE A PHOTO 93-67 TYPE B PHOTO 93-68 TYPE C PHOTO 93-69
	803	BRAKE COOLING SYSTEM FRONT AIR INLET DUCT* TYPE A PHOTO 93-70 TYPE B PHOTO 93-71 TYPE C PHOTO 93-72
		* - THE CROSS SECTION IS LESS THAN 78.4cm <sup>2</sup> * - THE MAXIMUM DIMENSION IS LESS THAN 25cm. * - THE AIR INTAKE IS NO FURTHER FORWARD THAT THE LOWEST POINT OF THE FRONT BUMPER.



Make  
会社名

MAZDA

Model  
型式

FAMILIA GT-R

No Homol.

A-5473

No Ext.

02/02V0

JAF公認番号 JA-151 VO- 2/2

Page or ext. ページまたは補足	Art. 項目	Description 記述
16, 17	803	BRAKE COOLING SYSTEM TYPE D* PHOTO 93-73 REAR AIR INLET DUCT *THE CROSS SECTION IS LESS THAN $78.4\text{cm}^2$ THE MAXIMUM DIMENSION IS LESS THAN 25cm
	803	BRAKE COOLING SYSTEM AIR DUCT ON FRONT KNUCKLE TYPE A* PHOTO 93-74 TYPE B* PHOTO 93-75
	803	BRAKE COOLING SYSTEM AIR DUCT ON REAR KNUCKLE TYPE A* PHOTO 93-76 TYPE B* PHOTO 93-77 * THE CROSS SECTION IS LESS THAN $78.4\text{cm}^2$
	803	HYDRAULIC FLY OFF HANDBRAKE PHOTO 93-78
	803	ALTERNATIVE HYDRAULIC FLY OFF HANDBRAKE PHOTO 93-79
	803	BRAKE DISC BELL (FRONT/REAR) TYPE A PHOTO 93-80 TYPE B PHOTO 93-81 TYPE C PHOTO 93-82





A-5473

Make  
会社名

MAZDA

Model  
型式

FAMILIA GT-R

No Homol.

No Ext.

0 &lt; / 0 2 V0

JAF公認番号

Page or ext. ページまたは補足	Art. 項目	Description 記述
16, 17	803	BRAKE DISC (FRONT AND/OR REAR BRAKES) PHOTO 93-83 *DISC MAY BE PLAIN, GROOVED OR CROSS DRILLED G4) MAXIMUM DISC THICKNESS: 25mm+/-1mm G5) EXTERIOR DIAMETER OF THE DISC: 275mm+/-1.5mm G6) EXTERIOR DIAMETER OF THE PAD'S RUBBING SURFACE: 275mm+/-1.5mm G7) INTERIOR DIAMETER OF THE PAD'S RUBBING SURFACE: 174mm+/-1.5mm *THE FRICTION MATERIAL ON THE PAD MAY BE NOT USE ALL THE DISC AREA AVAILABLE G9) VENTILATED DISC: YES PART NUMBER: RIGHT/LEFT: CP2261-708/709
	803	BRAKE DISC (FRONT AND/OR REAR BRAKES) PHOTO 93-84 *DISC MAY BE PLAIN, GROOVED OR CROSS DRILLED G4) MAXIMUM DISC THICKNESS: 22mm+/-1mm G5) EXTERIOR DIAMETER OF THE DISC: 275mm+/-1.5mm G6) EXTERIOR DIAMETER OF THE PAD'S RUBBING SURFACE: 275mm+/-1.5mm G7) INTERIOR DIAMETER OF THE PAD'S RUBBING SURFACE: 174mm+/-1.5mm *THE FRICTION MATERIAL ON THE PAD MAY BE NOT USE ALL THE DISC AREA AVAILABLE G9) VENTILATED DISC: YES PART NUMBER: RIGHT/LEFT: CP2261-698/699



Make  
会社名

MAZDA

Model

型式

FAMILIA GT-R

No Homol.

A-5473

No Ext.

02/02V0

JAF公認番号

Page or ext. ページまたは補足	Art. 項目	Description 記述
16, 17	803	BRAKE DISC (FRONT AND/OR REAR BRAKES) PHOTO 93-85 *DISC MAY BE PLAIN, GROOVED OR CROSS DRILLED G4) MAXIMUM DISC THICKNESS: 28mm+/-1mm G5) EXTERIOR DIAMETER OF THE DISC: 295mm+/-1.5mm G6) EXTERIOR DIAMETER OF THE PAD'S RUBBING SURFACE: 295mm+/-1.5mm G7) INTERIOR DIAMETER OF THE PAD'S RUBBING SURFACE: 196mm+/-1.5mm *THE FRICTION MATERIAL ON THE PAD MAY BE NOT USE ALL THE DISC AREA AVAILABLE G9) VENTILATED DISC: YES PART NUMBER: RIGHT/LEFT: CP3047-256/257
	803	BRAKE DISC (FRONT AND/OR REAR BRAKES) PHOTO 93-86 *DISC MAY BE PLAIN, GROOVED OR CROSS DRILLED G4) MAXIMUM DISC THICKNESS: 28mm+/-1mm G5) EXTERIOR DIAMETER OF THE DISC: 304mm+/-1.5mm *THE PAD'S RUBBING OF THE PAD'S RUBBING SURFACE: 304mm+/-1.5mm G7) INTERIOR DIAMETER OF THE PAD'S RUBBING SURFACE: 203mm+/-1.5mm *THE FRICTION MATERIAL ON THE PAD MAY BE NOT USE ALL THE DISC AREA AVAILABLE G9) VENTILATED DISC: YES PART NUMBER: RIGHT/LEFT: CP3047-65/67

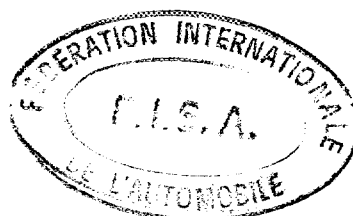

Make  
会社名

MAZDA

Model

型式 FAMILIA GT-R

No Homol.

A-5473

No Ext.

02/02V0

JAF公認番号

Page or ext. ページまたは補足	Art. 項目	Description 記述
16, 17	803	<p>BRAKE DISC (FRONT AND/OR REAR BRAKES) PHOTO 93-87</p> <p>*DISC MAY BE PLAIN, GROOVED OR CROSS DRILLED</p> <p>G4) MAXIMUM DISC THICKNESS: 28mm+/-1mm</p> <p>G5) EXTERIOR DIAMETER OF THE DISC: 315mm+/-1.5mm</p> <p>G6) EXTERIOR DIAMETER OF THE PAD'S RUBBING SURFACE: 315mm+/-1.5mm</p> <p>G7) INTERIOR DIAMETER OF THE PAD'S RUBBING SURFACE: 220mm+/-1.5mm</p> <p>*THE FRICTION MATERIAL ON THE PAD MAY BE NOT USE ALL THE DISC AREA AVAILABLE</p> <p>G9) VENTILATED DISC: YES</p> <p>PART NUMBER: RIGHT/LEFT: CP3047-178/179</p>
	803	<p>BRAKE DISC (FRONT AND/OR REAR BRAKES) PHOTO 93-88</p> <p>*DISC MAY BE PLAIN, GROOVED OR CROSS DRILLED</p> <p>G4) MAXIMUM DISC THICKNESS: 28mm+/-1mm</p> <p>G5) EXTERIOR DIAMETER OF THE DISC: 330mm+/-1.5mm</p> <p>G6) EXTERIOR DIAMETER OF THE PAD'S RUBBING SURFACE: 330mm+/-1.5mm</p> <p>G7) INTERIOR DIAMETER OF THE PAD'S RUBBING SURFACE: 220mm+/-1.5mm</p> <p>*THE FRICTION MATERIAL ON THE PAD MAY BE NOT USE ALL THE DISC AREA AVAILABLE</p> <p>G9) VENTILATED DISC: YES</p> <p>PART NUMBER: RIGHT/LEFT: CP3047-252/253</p>



Make  
会社名

MAZDA

Model

型式 FAMILIA GT-R

No Homol.

A-5473

No Ext.

02/02V0

JAF公認番号 JA-151 VO- 2/2

Page or ext. ページまたは補足	Art. 項目	Description 記述																								
16, 17	803	BRAKE CALIPER (FRONT AND/OR REAR BRAKES) PHOTO 93-89 *CALIPERS IDENTICAL EXCEPT FOR INTERNAL MACHINING																								
<table border="1"><tbody><tr><td>E) NUMBER OF CYLINDERS PER WHEEL:</td><td>4</td><td>4</td></tr><tr><td>E1) CYLINDER BORE:</td><td>36.1mm</td><td>34mm</td></tr><tr><td>G1) NUMBER OF PADS PER WHEEL:</td><td>2</td><td>2</td></tr><tr><td>G2) NUMBER OF CALIPERS PER WHEEL:</td><td>1</td><td>1</td></tr><tr><td>G3) CALIPER MATERIAL:</td><td>ALUMINUM ALLOY</td><td>ALUMINUM ALLOY</td></tr><tr><td>G8) OVER ALL LENGTH OF PAD:</td><td>105.2mm ±1.5mm</td><td>105.2mm ±1.5mm</td></tr><tr><td>PART NUMBER: RIGHT.</td><td>ZR01-33-980</td><td>ZR01-26-980</td></tr><tr><td>LEFT</td><td>ZR01-33-990</td><td>ZR01-26-990</td></tr></tbody></table>			E) NUMBER OF CYLINDERS PER WHEEL:	4	4	E1) CYLINDER BORE:	36.1mm	34mm	G1) NUMBER OF PADS PER WHEEL:	2	2	G2) NUMBER OF CALIPERS PER WHEEL:	1	1	G3) CALIPER MATERIAL:	ALUMINUM ALLOY	ALUMINUM ALLOY	G8) OVER ALL LENGTH OF PAD:	105.2mm ±1.5mm	105.2mm ±1.5mm	PART NUMBER: RIGHT.	ZR01-33-980	ZR01-26-980	LEFT	ZR01-33-990	ZR01-26-990
E) NUMBER OF CYLINDERS PER WHEEL:	4	4																								
E1) CYLINDER BORE:	36.1mm	34mm																								
G1) NUMBER OF PADS PER WHEEL:	2	2																								
G2) NUMBER OF CALIPERS PER WHEEL:	1	1																								
G3) CALIPER MATERIAL:	ALUMINUM ALLOY	ALUMINUM ALLOY																								
G8) OVER ALL LENGTH OF PAD:	105.2mm ±1.5mm	105.2mm ±1.5mm																								
PART NUMBER: RIGHT.	ZR01-33-980	ZR01-26-980																								
LEFT	ZR01-33-990	ZR01-26-990																								



Make  
会社名

MAZDA

Model  
型式

FAMILIA GT-R

No Homol.

A-5473

No Ext.

02/02V0

JAF公認番号 JA-151 VO- 2/2

Page or ext. ~	Art. 項目	Description 記述																					
16, 17	803	<p>BRAKE CALIPER (FRONT AND/OR REAR BRAKES) PHOTO 93-90 *CALIPERS IDENTICAL EXCEPT FOR INTERNAL MACHINING</p> <table border="1" data-bbox="502 757 1369 1585"> <tr> <td data-bbox="502 757 901 873">E) NUMBER OF CYLINDERS PER WHEEL:</td> <td data-bbox="901 757 1141 873">4</td> <td data-bbox="1141 757 1369 873">4</td> </tr> <tr> <td data-bbox="502 873 901 990">E1) CYLINDER BORE:</td> <td data-bbox="901 873 1141 990">2×38.1mm 2×41.3mm</td> <td data-bbox="1141 873 1369 990">31.75mm</td> </tr> <tr> <td data-bbox="502 990 901 1106">G1) NUMBER OF PADS PER WHEEL:</td> <td data-bbox="901 990 1141 1106">2</td> <td data-bbox="1141 990 1369 1106">2</td> </tr> <tr> <td data-bbox="502 1106 901 1223">G2) NUMBER OF CALIPERS PER WHEEL:</td> <td data-bbox="901 1106 1141 1223">1</td> <td data-bbox="1141 1106 1369 1223">1</td> </tr> <tr> <td data-bbox="502 1223 901 1348">G3) CALIPER MATERIAL:</td> <td data-bbox="901 1223 1141 1348">ALUMINUM ALLOY</td> <td data-bbox="1141 1223 1369 1348">ALUMINUM ALLOY</td> </tr> <tr> <td data-bbox="502 1348 901 1464">G8) OVERALL LENGTH OF PAD:</td> <td data-bbox="901 1348 1141 1464">112.25mm ±1.5mm</td> <td data-bbox="1141 1348 1369 1464">112.25mm ±1.5mm</td> </tr> <tr> <td data-bbox="502 1464 901 1585">PART NUMBER: RIGHT LEFT</td> <td data-bbox="901 1464 1141 1585">CP3481-12U4N CP3481-13U4N</td> <td data-bbox="1141 1464 1369 1585">CP3556-254 CP3556-354</td> </tr> </table>	E) NUMBER OF CYLINDERS PER WHEEL:	4	4	E1) CYLINDER BORE:	2×38.1mm 2×41.3mm	31.75mm	G1) NUMBER OF PADS PER WHEEL:	2	2	G2) NUMBER OF CALIPERS PER WHEEL:	1	1	G3) CALIPER MATERIAL:	ALUMINUM ALLOY	ALUMINUM ALLOY	G8) OVERALL LENGTH OF PAD:	112.25mm ±1.5mm	112.25mm ±1.5mm	PART NUMBER: RIGHT LEFT	CP3481-12U4N CP3481-13U4N	CP3556-254 CP3556-354
E) NUMBER OF CYLINDERS PER WHEEL:	4	4																					
E1) CYLINDER BORE:	2×38.1mm 2×41.3mm	31.75mm																					
G1) NUMBER OF PADS PER WHEEL:	2	2																					
G2) NUMBER OF CALIPERS PER WHEEL:	1	1																					
G3) CALIPER MATERIAL:	ALUMINUM ALLOY	ALUMINUM ALLOY																					
G8) OVERALL LENGTH OF PAD:	112.25mm ±1.5mm	112.25mm ±1.5mm																					
PART NUMBER: RIGHT LEFT	CP3481-12U4N CP3481-13U4N	CP3556-254 CP3556-354																					



Make  
会社名

MAZDA

Model

型式 FAMILIA GT-R

No Homol.

A-5473

No Ext.

~~02/02V0~~

JAF公認番号 JA-151 VO- 2/2

Page or ext., ページまたは補足	Art. 項目	Description 記述														
16, 17	803	BRAKE CALIPER (FRONT AND/OR REAR BRAKES) PHOTO 93-91 <table border="1" data-bbox="587 745 1214 1574"><tr><td>E) NUMBER OF CYLINDERS PER WHEEL:</td><td>4</td></tr><tr><td>E1) CYLINDER BORE:</td><td>2×44.45mm 2×38.1mm</td></tr><tr><td>G1) NUMBER OF PADS PER WHEEL:</td><td>2</td></tr><tr><td>G2) NUMBER OF CALIPERS PER WHEEL:</td><td>1</td></tr><tr><td>G3) CALIPER MATERIAL:</td><td>ALUMINUM ALLOY</td></tr><tr><td>G8) OVERALL LENGTH OF PAD:</td><td>131.32mm ±1.5mm</td></tr><tr><td>PART NUMBER: RIGHT LEFT</td><td>CP3720-46 CP3720-57</td></tr></table>	E) NUMBER OF CYLINDERS PER WHEEL:	4	E1) CYLINDER BORE:	2×44.45mm 2×38.1mm	G1) NUMBER OF PADS PER WHEEL:	2	G2) NUMBER OF CALIPERS PER WHEEL:	1	G3) CALIPER MATERIAL:	ALUMINUM ALLOY	G8) OVERALL LENGTH OF PAD:	131.32mm ±1.5mm	PART NUMBER: RIGHT LEFT	CP3720-46 CP3720-57
E) NUMBER OF CYLINDERS PER WHEEL:	4															
E1) CYLINDER BORE:	2×44.45mm 2×38.1mm															
G1) NUMBER OF PADS PER WHEEL:	2															
G2) NUMBER OF CALIPERS PER WHEEL:	1															
G3) CALIPER MATERIAL:	ALUMINUM ALLOY															
G8) OVERALL LENGTH OF PAD:	131.32mm ±1.5mm															
PART NUMBER: RIGHT LEFT	CP3720-46 CP3720-57															



Make  
会社名

MAZDA

Model  
型式

FAMILIA GT-R

No Homol.

A-5473

No Ext.

02/02V0

JAF公認番号 JA-151 VO- 2/2

Page or ext. ページまたは補足	Art. 項目	Description 記述	
16, 17	803	BRAKE CALIPER MOUNTING-FRONT FOR ORIGINAL KNUCKLE	PHOTO 93-92
	803	BRAKE CALIPER MOUNTING-REAR FOR ORIGINAL KNUCKLE	PHOTO 93-93
	804	REINFORCED POWER STEERING RACK *INTERCHANGEABLE WITH ORIGINAL PART	PHOTO 93-94
	804	ALTERNATIVE STEERING RATIO FOR POWER AND NON-POWER STEERING RACKS:13.0:1±0.25 *NON-POWER RACKS DISPENSE WITH NEED FOR POWER STEERING PUMP	
	804	REINFORCED STEERING COLUMN	PHOTO 93-95
	804	ALTERNATIVE REINFORCED STEERING COLUMN	PHOTO 93-96
	804	REINFORCED STEERING COLUMN FIXATION	PHOTO 93-97
	804	ALTERNATIVE POWER STEERING PUMP	PHOTO 93-98
	804	INCREASED VOLUME RESERVOIR FOR POWER STEERING PUMP (CAPACITY:0.8L+/-0.1L)	PHOTO 93-99

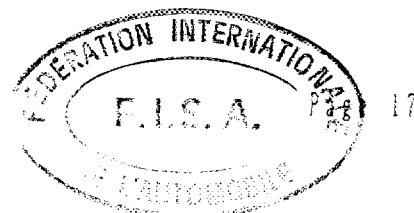

Make MAZDA Model FAMILIA GT-R No Homol. A-5473  
 会社名

No Ext. 02/02V0

JAF公認番号 JA-151 VO- 2/2

Page or ext. ページまたは補足	Art. 項目	Description 記述
18	9	<u>BODYWORK:</u>
	901	SUN ROOF (FOR RALLY ONLY) PHOTO 93-100 F1) TYPE: RISING PHOTO 93-101 F2) CONTROL SYSTEM: MANUAL *MAXIMUM HEIGHT IS WITHIN 100mm MAXIMUM WIDTH IS WITHIN 500mm SITUATED WITHIN THE FIRST THIRD OF THE ROOF.
	901	SEAT SUPPORT IN ALUMINUM (5mm THICKNESS PHOTO 93-102 MINIMUM) OR STEEL (3mm THICKNESS MINIMUM) *USING 4 ATTACHMENTS PER SEAT AND 8mm BOLTS.
	901	ALTERNATIVE SEAT SUPPORT IN ALUMINUM PHOTO 93-103 (5mm THICKNESS MINIMUM) OR STEEL (3mm THICKNESS MINIMUM) *USING 4 ATTACHMENTS PER SEAT AND 8mm BOLTS.
	901	ALTERNATIVE SEAT SUPPORT IN ALUMINUM PHOTO 93-104 (5mm THICKNESS MINIMUM) OR STEEL (3mm THICKNESS MINIMUM) *USING 4 ATTACHMENTS PER SEAT AND 8mm BOLTS.
	901	ALTERNATIVE SEAT SUPPORT IN ALUMINUM PHOTO 93-105 (5mm THICKNESS MINIMUM) OR STEEL (3mm THICKNESS MINIMUM) *USING 4 ATTACHMENTS PER SEAT AND 8mm BOLTS.
	901	SEAT SUPPORTS ANCHORAGES POINTS ON CHASSIS PHOTO 93-106 DRIVER SIDE. *4 ATTACHMENTS WITH 8mm BOLTS
	901	SEAT SUPPORTS ANCHORAGES POINTS ON CHASSIS PHOTO 93-107 CO-DRIVER SIDE. *4 ATTACHMENTS WITH 8mm BOLTS





Make  
会社名 MAZDA

Model  
型式 FAMILIA GT-R

No Homol. A-5473

No Ext. 02/02VO

JAF公認番号 JA-151 VO- 2/2

Page or ext. ページまたは補足	Art. 項目	Description 記述
18	901	SAFETY BELTS FIXING POINTS ・ DRIVER SIDE : 3POINTS PHOTO 93-108 ・ CODRIVER SIDE: 3POINTS PHOTO 93-109 ・ REAR: 2POINTS PER SIDE PHOTO 93-110



Make MAZDA Model FAMILIA GT-R No Homol. A-5473  
会社名 型式

No Ext. 02/02V0

JAF公認番号 JA-151 VO- 2/2

PHOTO 93-01

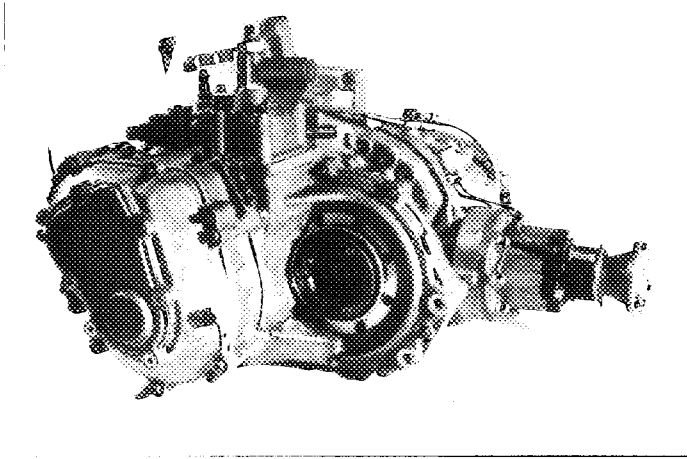

PHOTO 93-02

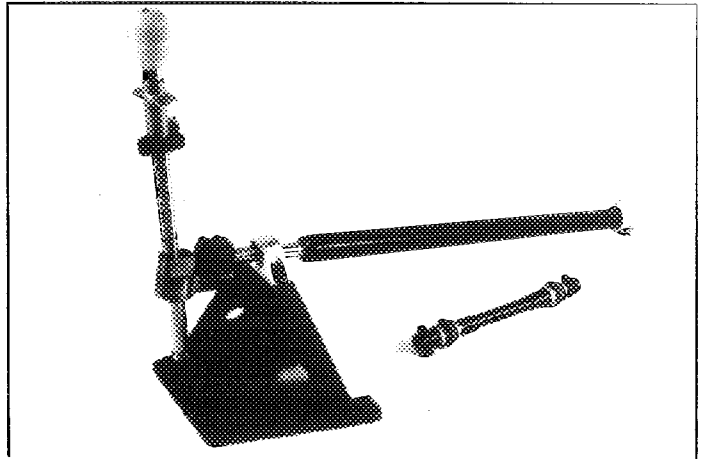

PHOTO 93-03

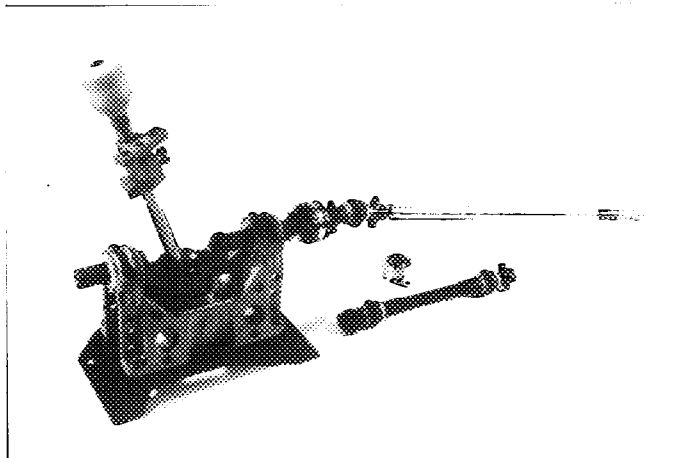

PHOTO 93-04



PHOTO 93-05

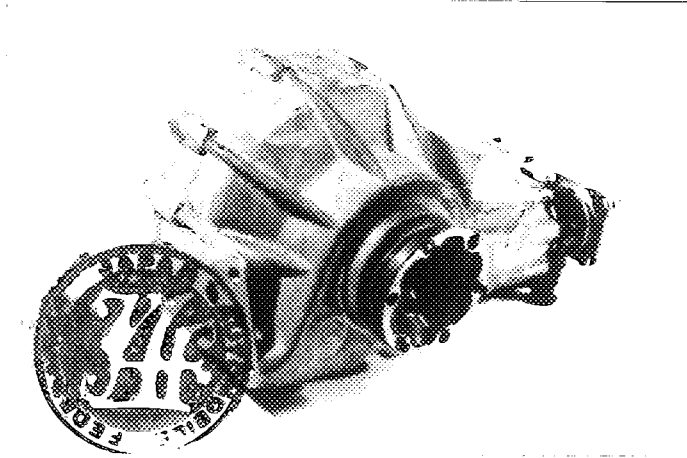

PHOTO 93-06



FEDERATION INTERNATIONALE  
JAF  
MOTORSPORTS

Make  
会社名

MAZDA

Model  
型式

FAMILIA GT-R

No Homol. A-5473

No Ext. 02/02V0

JAF公認番号 JA-151 VO- 2/2

PHOTO 93-07

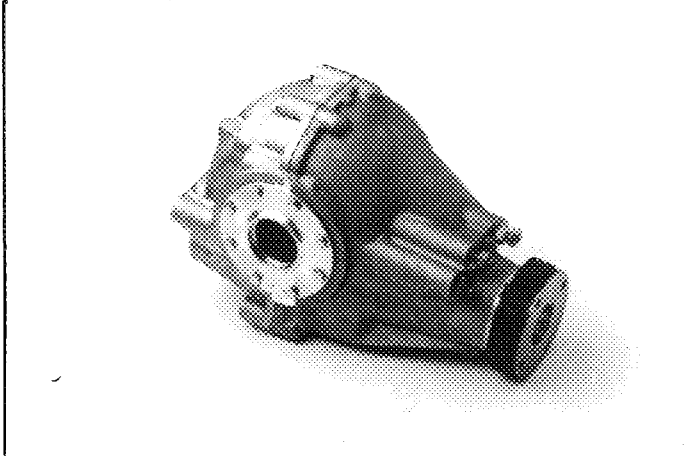

PHOTO 93-08

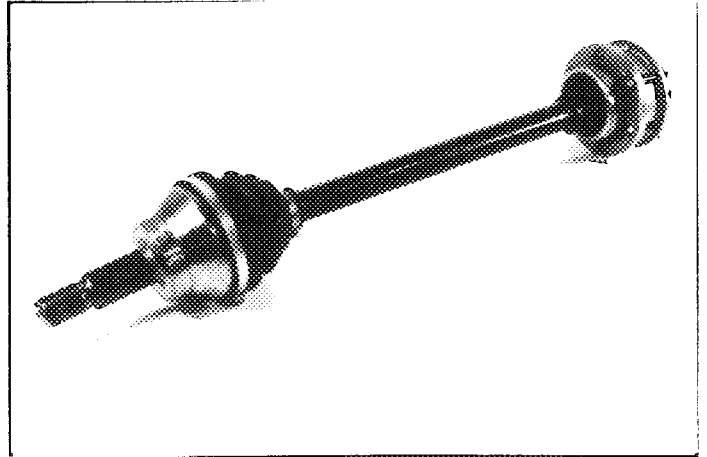

PHOTO 93-09

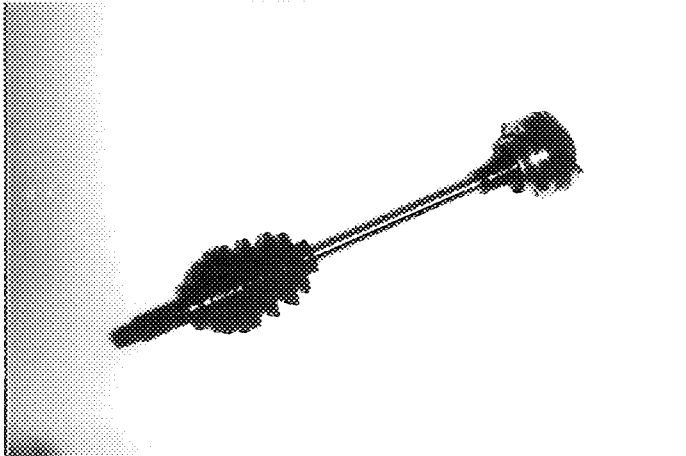

PHOTO 93-10

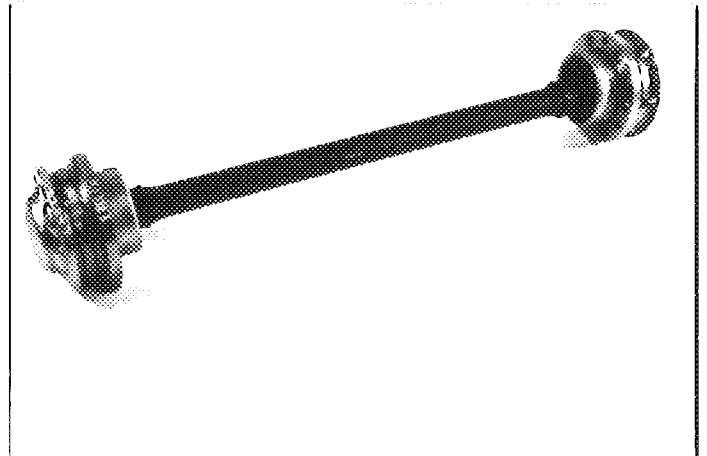

PHOTO 93-11

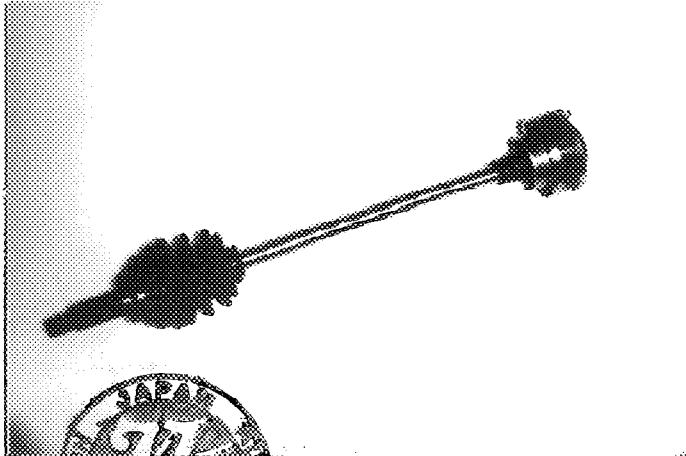
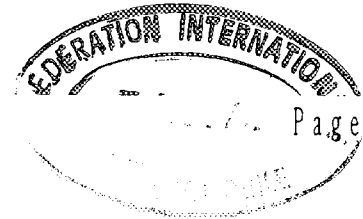
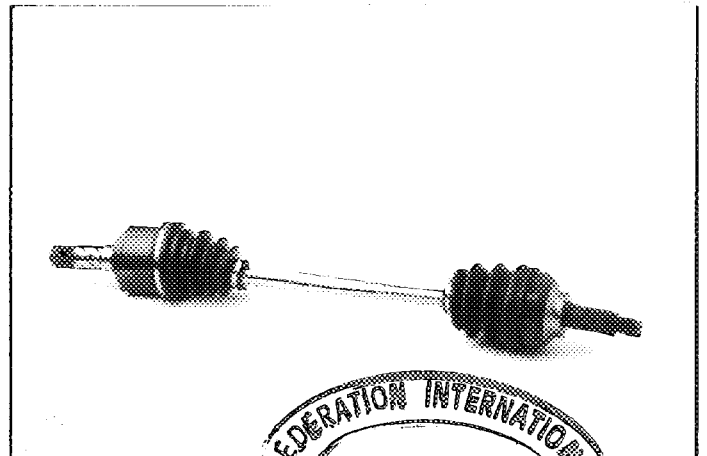

PHOTO 93-12



Make  
会社名

MAZDA

Model  
型式

FAMILIA GT-R

No Homol. A-5473

No Ext. 02/02V0

JAF公認番号 JA-151 VO- 2/2

PHOTO 93-13

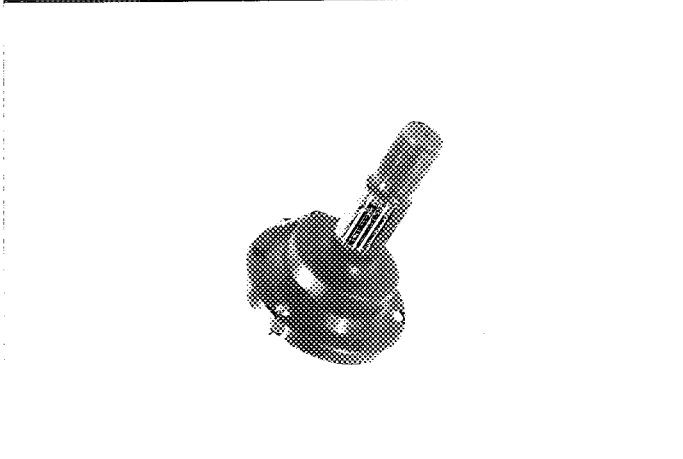

PHOTO 93-14



PHOTO 93-15

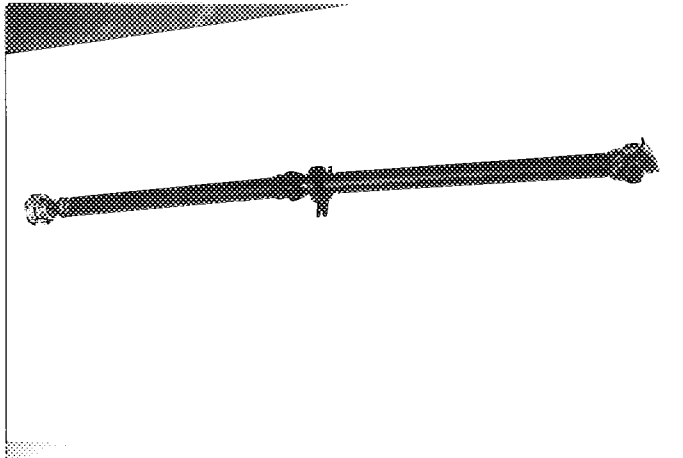

PHOTO 93-16

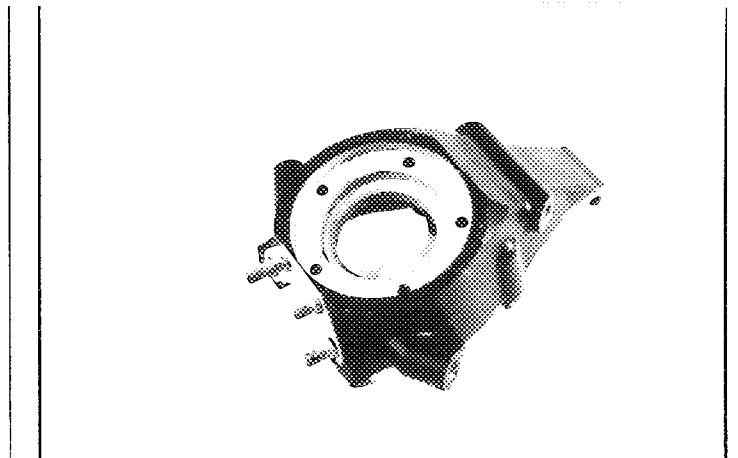
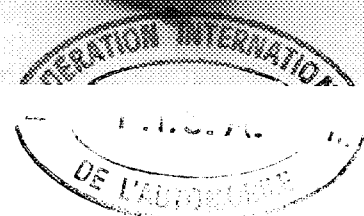
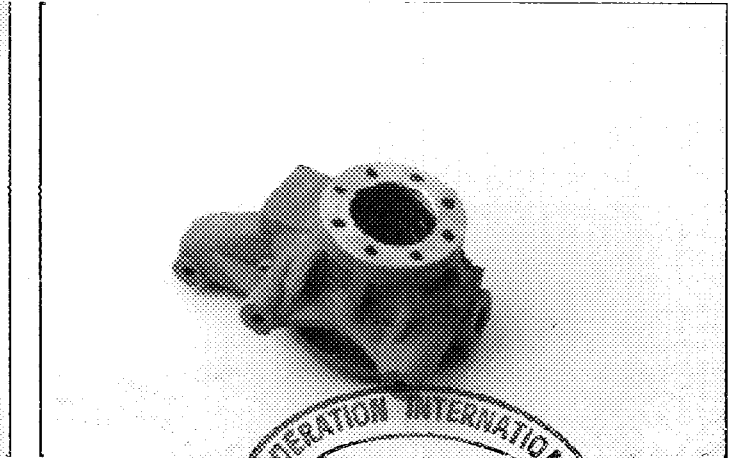

PHOTO 93-17



PHOTO 93-18



Make  
会社名

MAZDA

Model  
型式

FAMILIA GT-R

No Homol. A-5473

No Ext. 02/02V0

JAF公認番号 JA-151 VO- 2/2

PHOTO 93-19

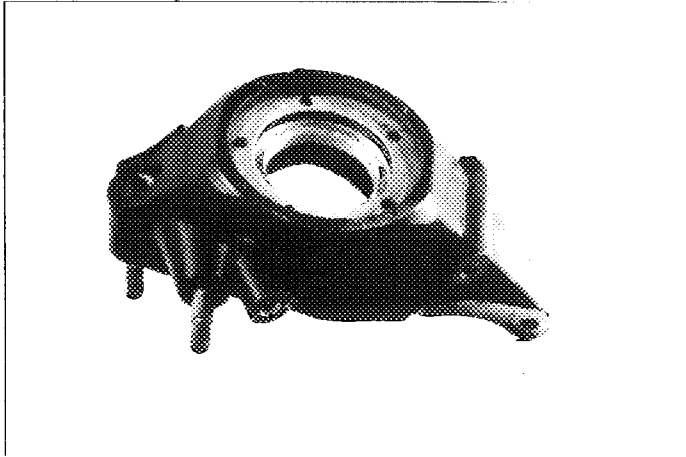

PHOTO 93-20

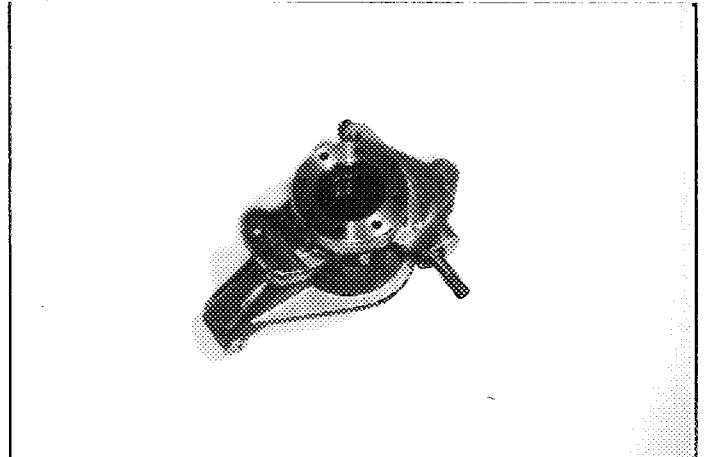

PHOTO 93-21



PHOTO 93-22

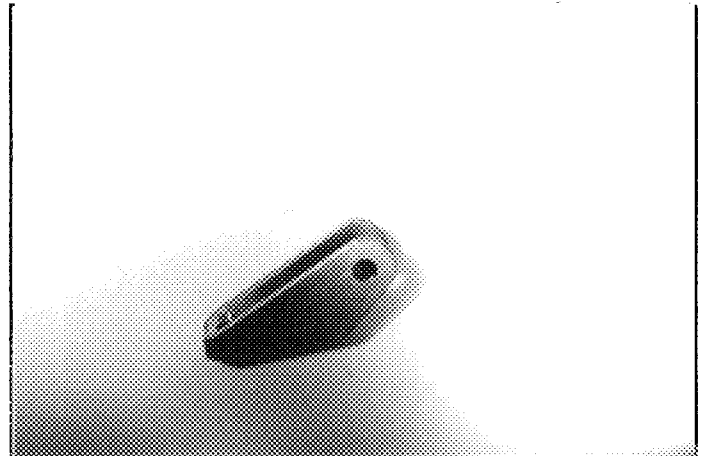

PHOTO 93-23

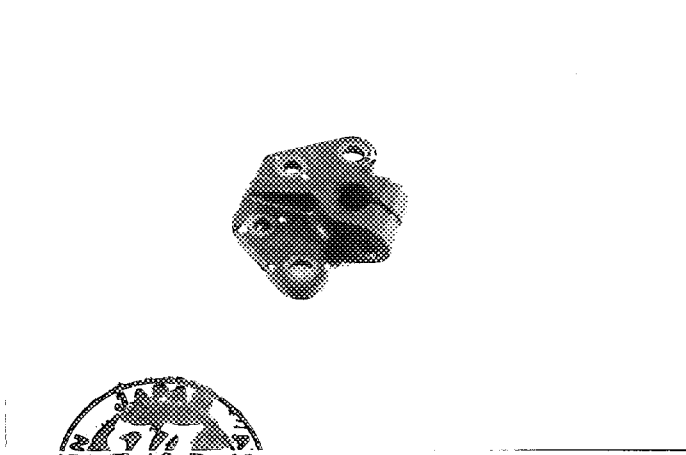
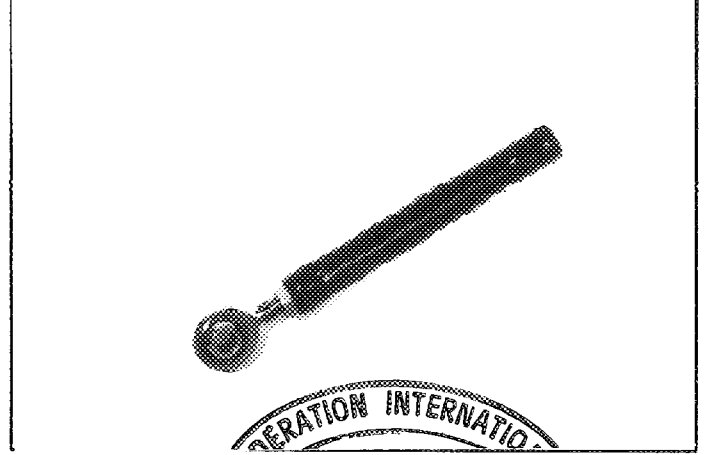

PHOTO 93-24



Make 会社名 MAZDA Model 型式 FAMILIA GT-R No Homol. A-5473

No Ext. 02/02V0

JAF公認番号 JA-151 VO- 2/2

PHOTO 93-25

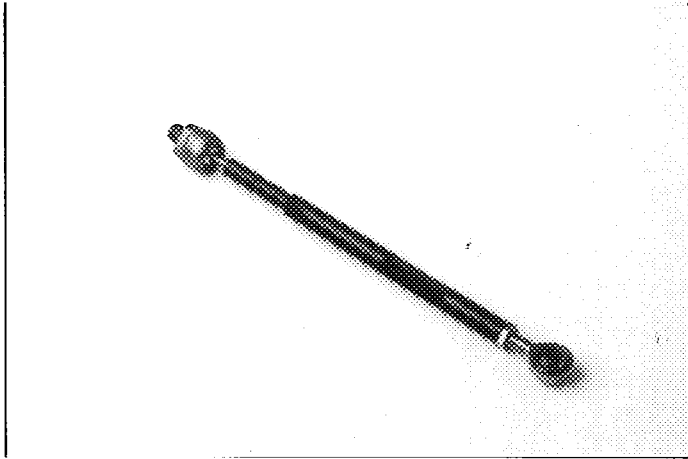

PHOTO 93-26

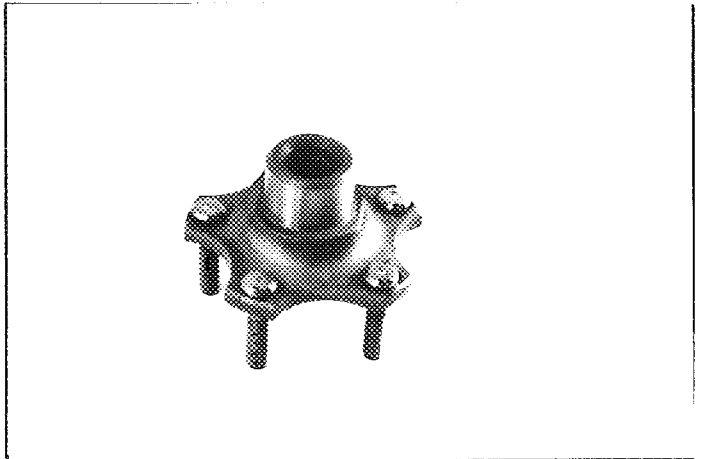

PHOTO 93-27

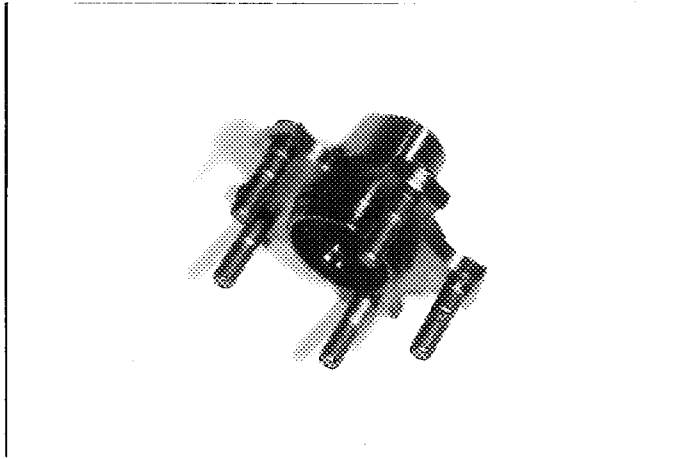

PHOTO 93-28

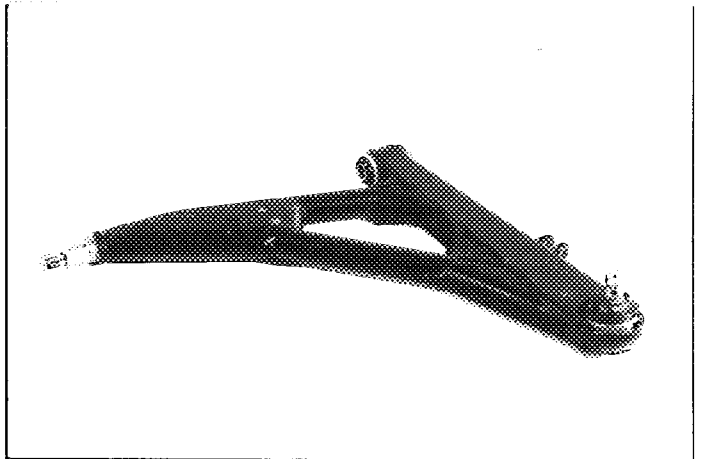

PHOTO 93-29

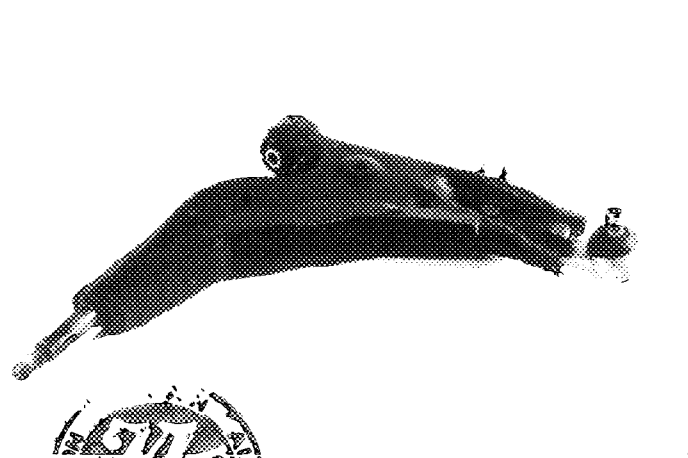

PHOTO 93-30



Make 会社名 MAZDA Model 型式 FAMILIA GT-R No Homol. A-5473

No Ext. 02/02V0

JAF公認番号 JA-151 VO- 2/2

PHOTO 93-31

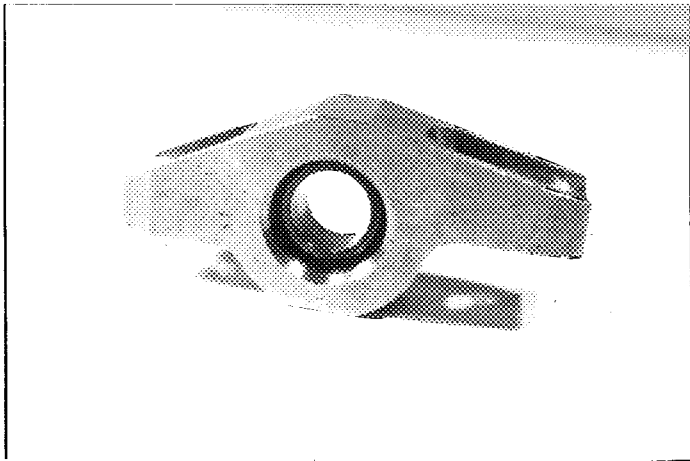

PHOTO 93-32

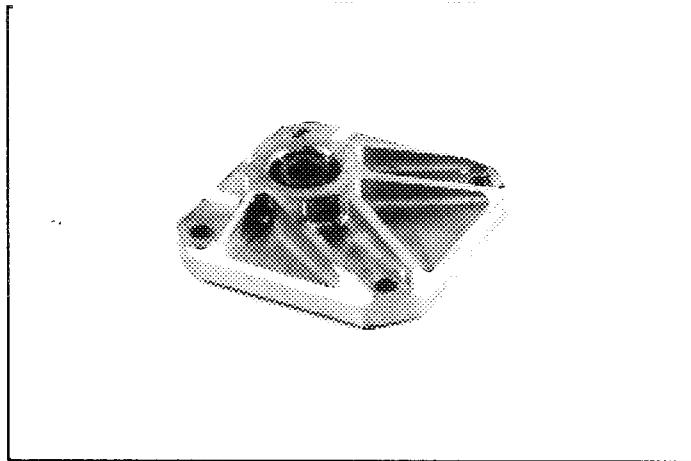

PHOTO 93-33

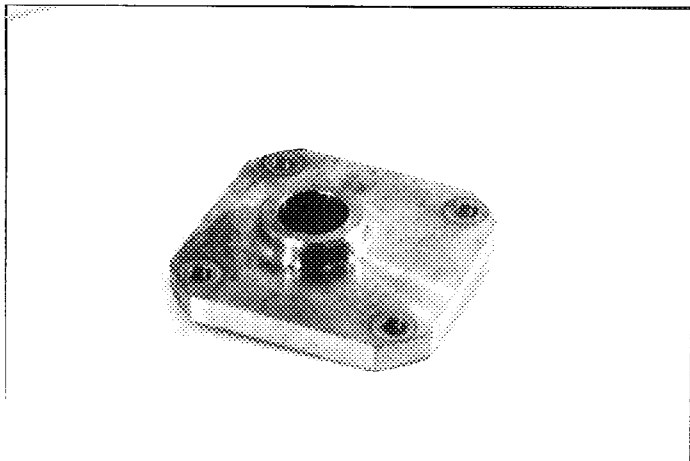

PHOTO 93-34

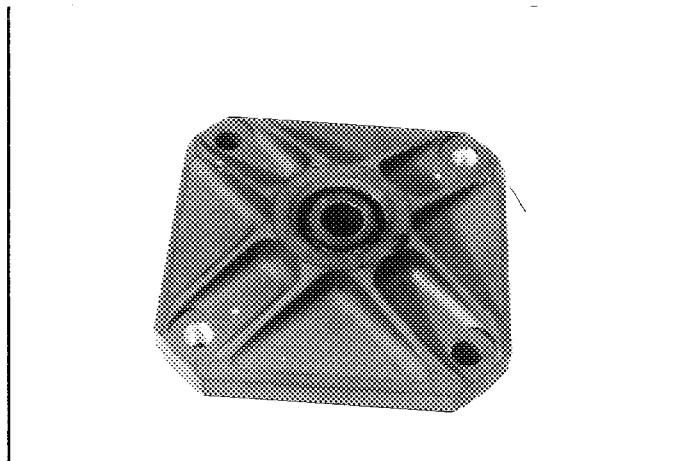

PHOTO 93-35

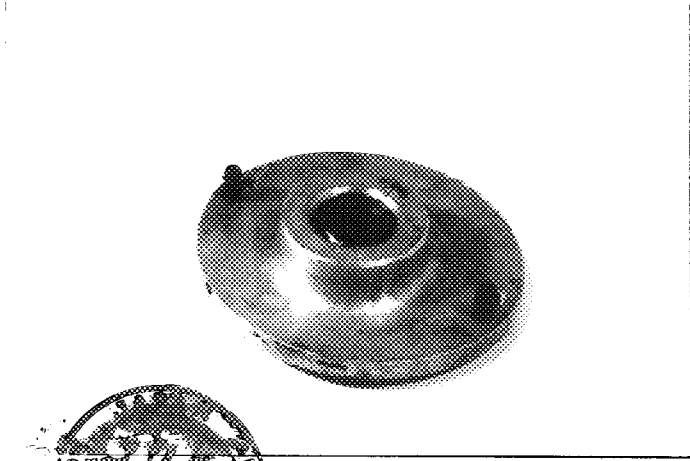
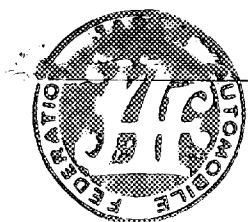
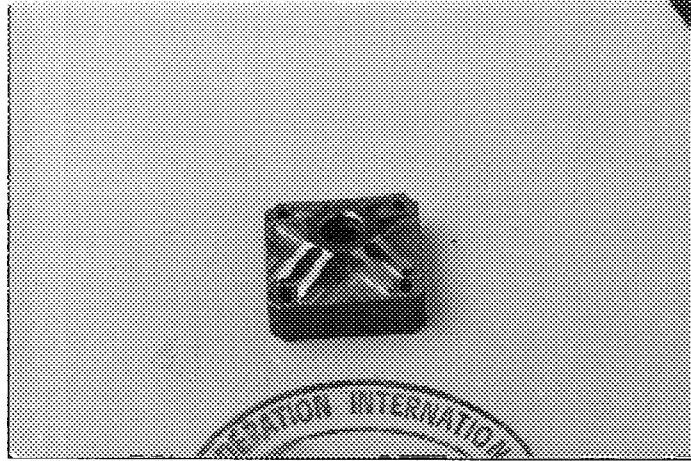

PHOTO 93-36



Make  
会社名

MAZDA

Model  
型式

FAMILIA GT-R

No Homol. A-5473

No Ext. 02/02V0

JAF公認番号 JA-151 VO- 2/2

PHOTO 93-37



PHOTO 93-38

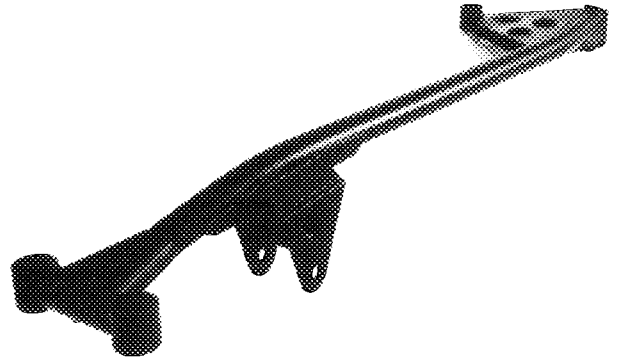

PHOTO 93-39



PHOTO 93-40

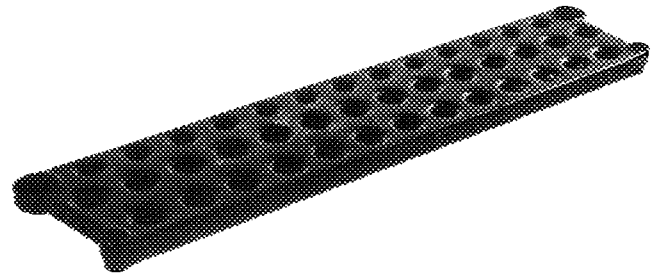

PHOTO 93-41

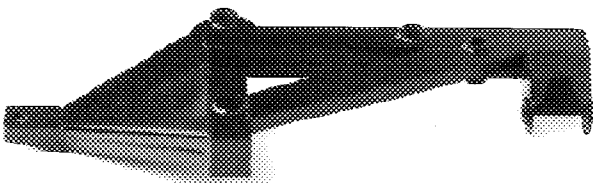
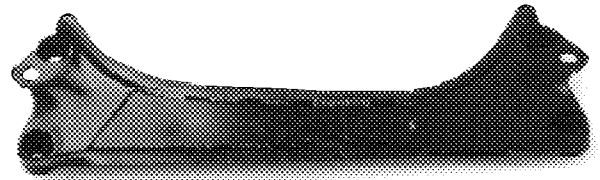

PHOTO 93-42





Make  
会社名

MAZDA

Model  
型式

FAMILIA GT-R

No Homol. A-5473

No Ext. 02/02V0

JAF公認番号 JA-151 VO- 2/2

PHOTO 93-43

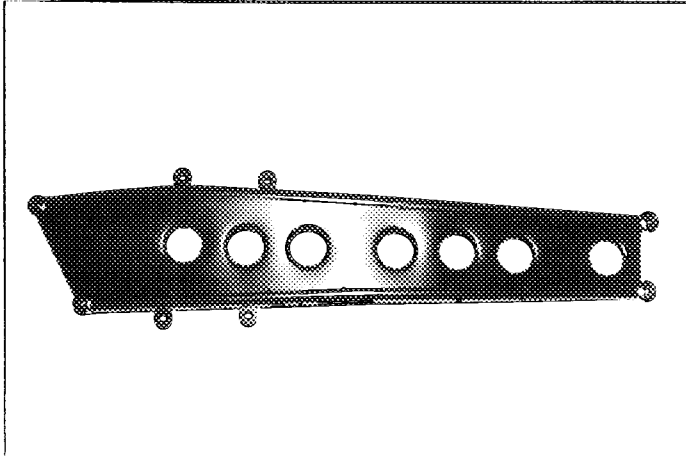

PHOTO 93-44

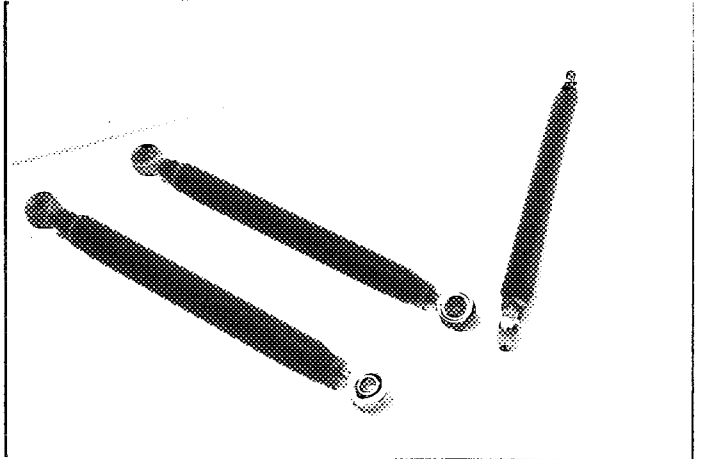

PHOTO 93-45



PHOTO 93-46

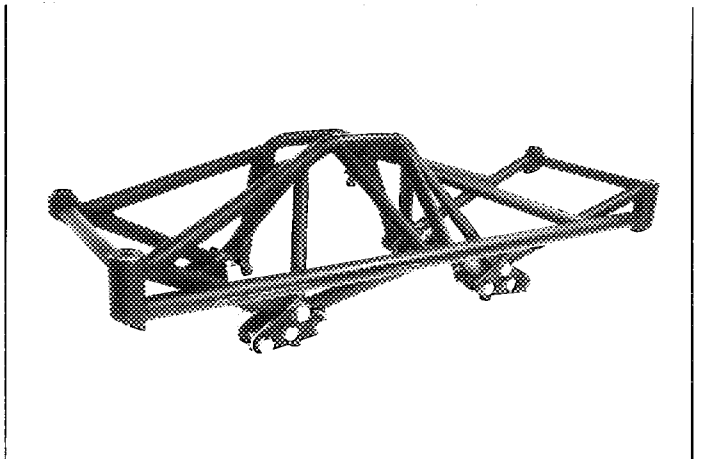

PHOTO 93-47

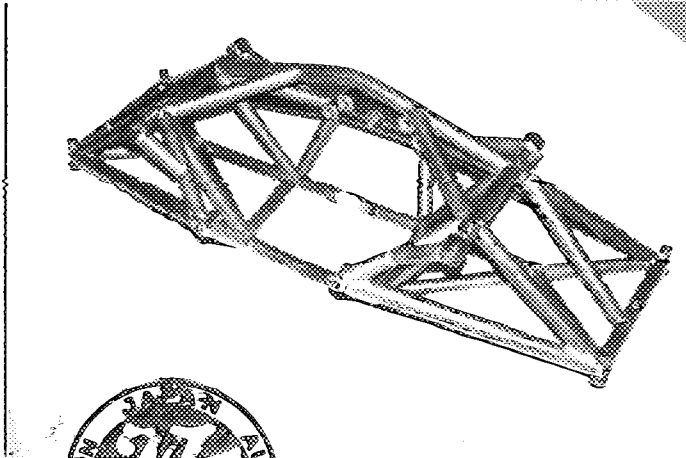
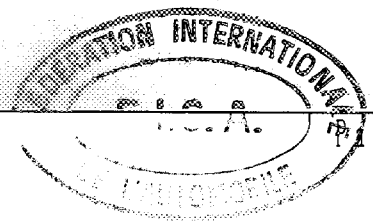
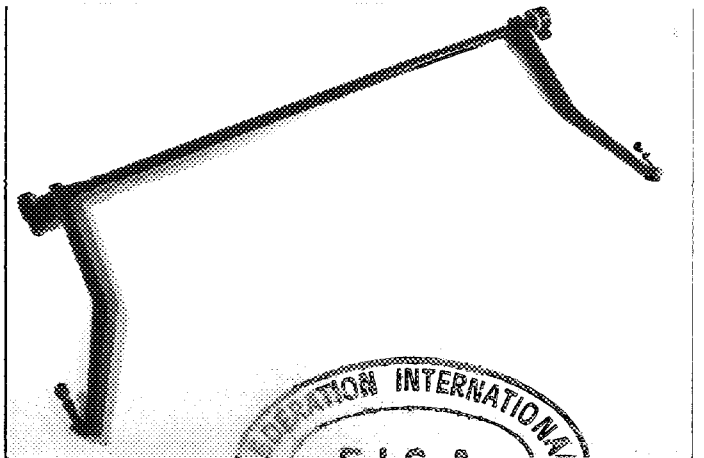

PHOTO 93-48



Make  
会社名

MAZDA

Model  
型式

FAMILIA GT-R

No Homol.

A-5473

No Ext.

02/02VO

JAF公認番号A-151 VO- 2/2

PHOTO 93-49

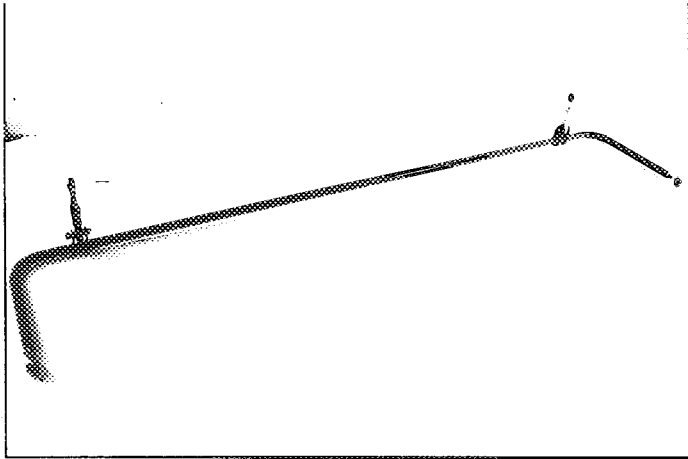

PHOTO 93-50

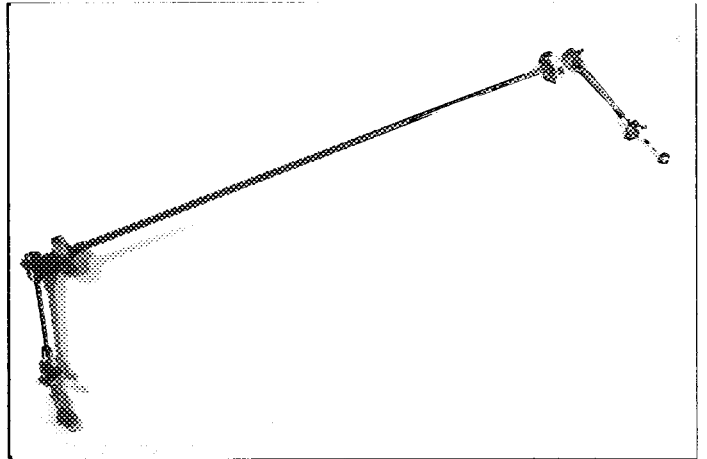

PHOTO 93-51

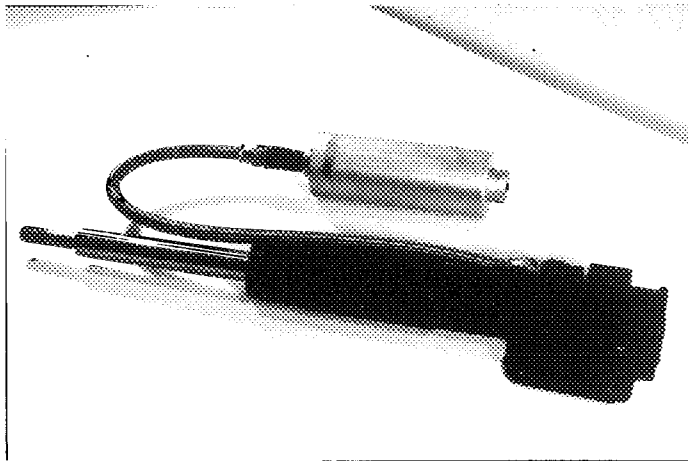

PHOTO 93-52

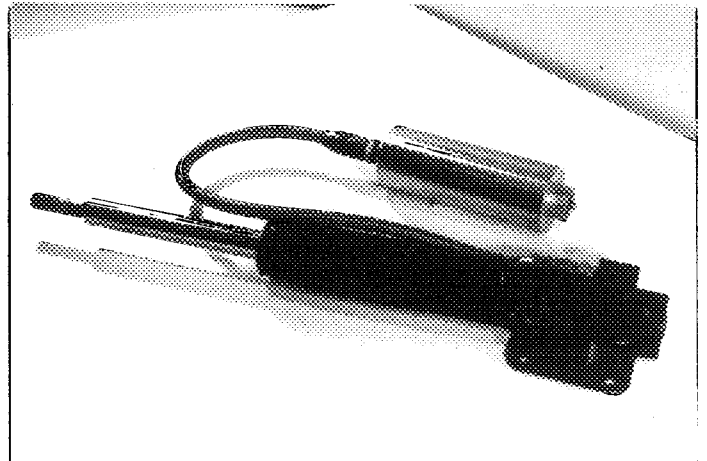

PHOTO 93-53

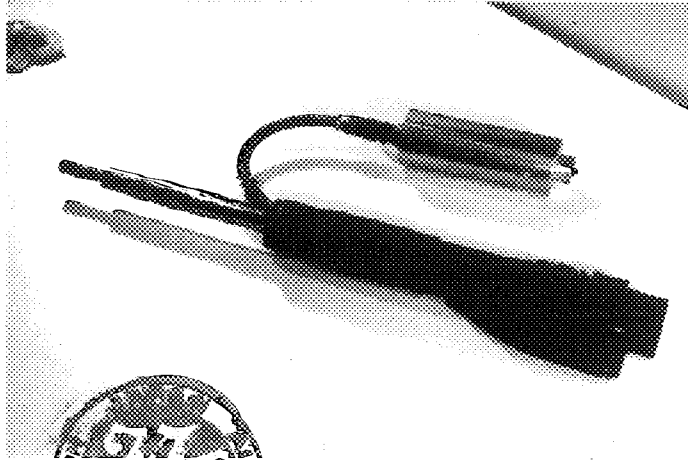
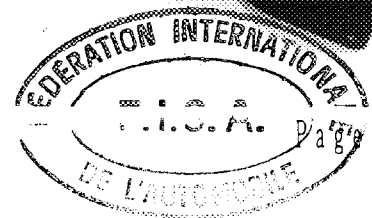
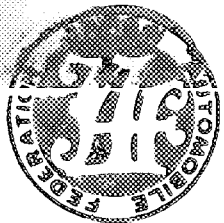

PHOTO 93-54



Make 会社名 MAZDA Model 型式 FAMILIA GT-R No Homol. A-5473

No Ext. 02/02V0

JAF公認番号 JA-151 VO- 2/2

PHOTO 93-55

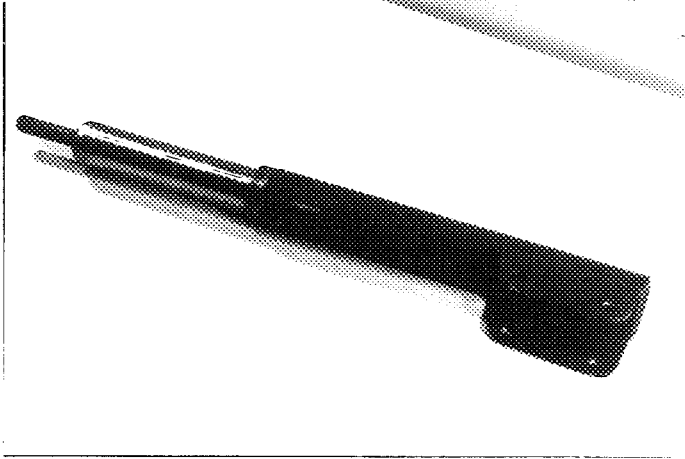

PHOTO 93-56

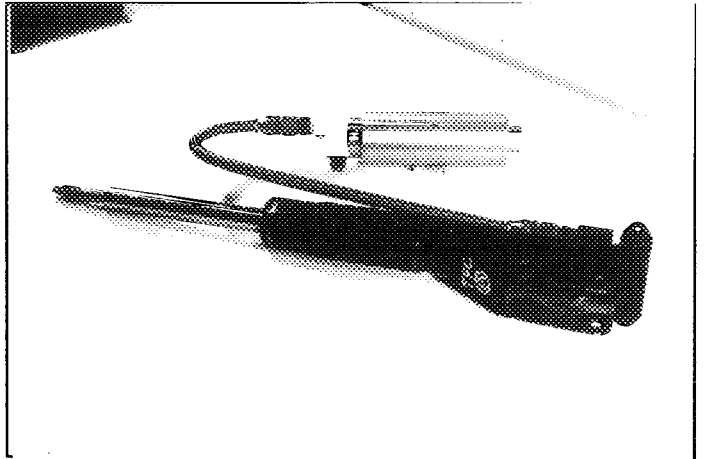

PHOTO 93-57

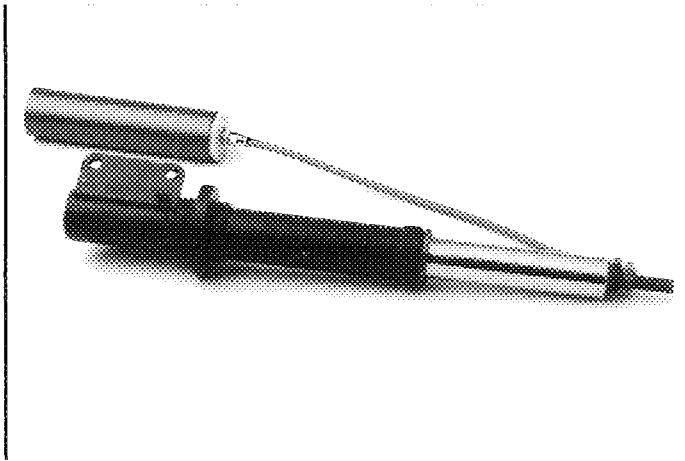

PHOTO 93-58

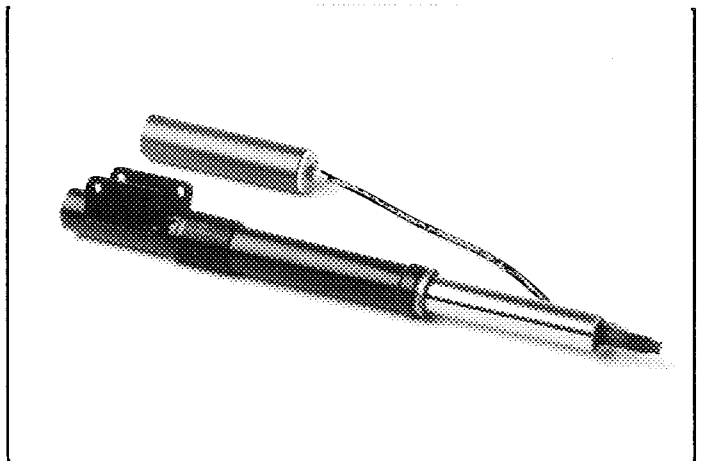

PHOTO 93-59

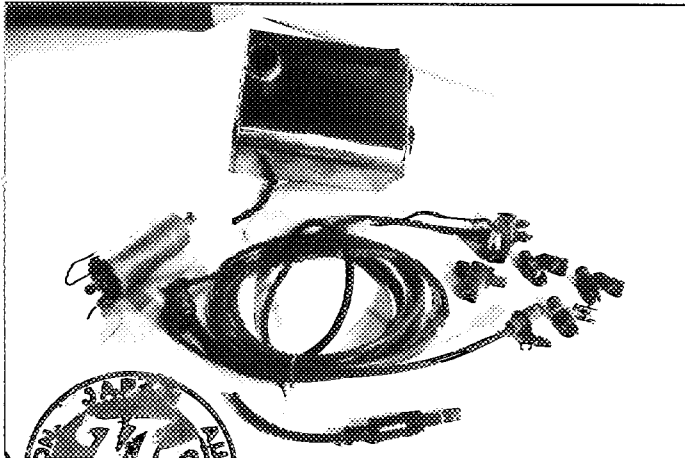
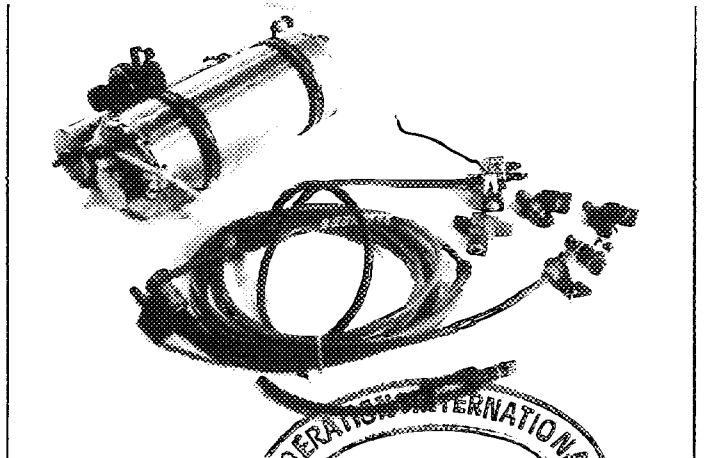

PHOTO 93-60



Make  
会社名

MAZDA

Model  
型式

FAMILIA GT-R

No Homol.

A-5473

No Ext.

02/02V0

JAF公認番号 JA-151 VO- 2/2

PHOTO 93-61

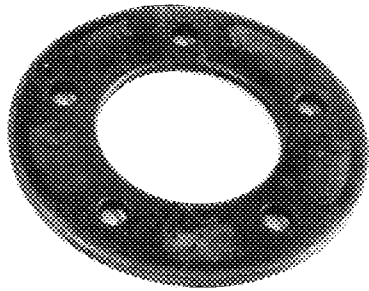

PHOTO 93-62

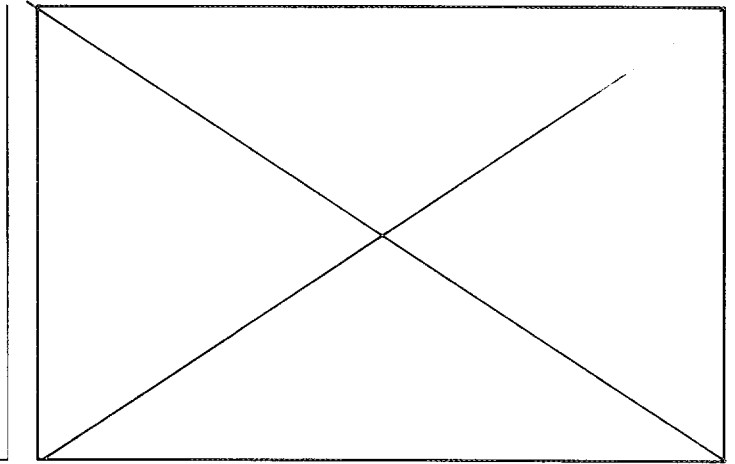

PHOTO 93-63

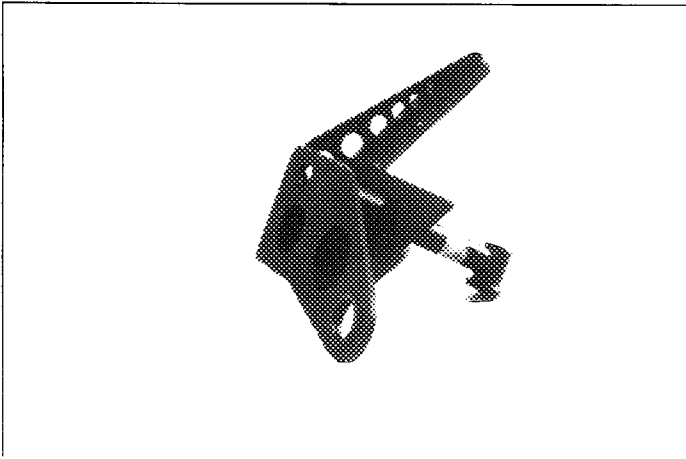

PHOTO 93-64



PHOTO 93-65

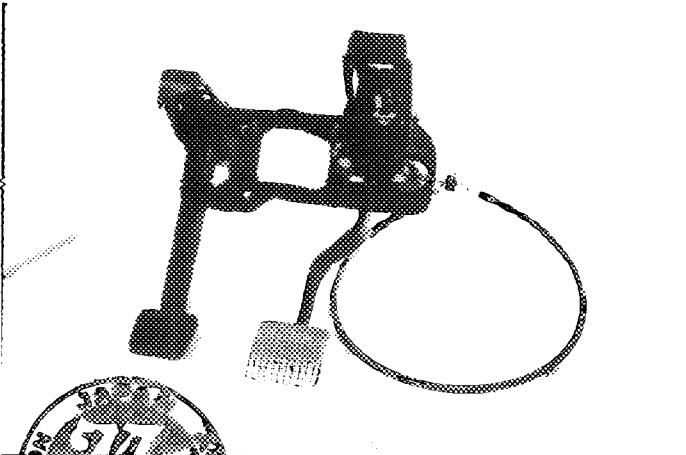
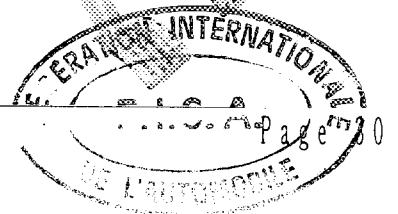
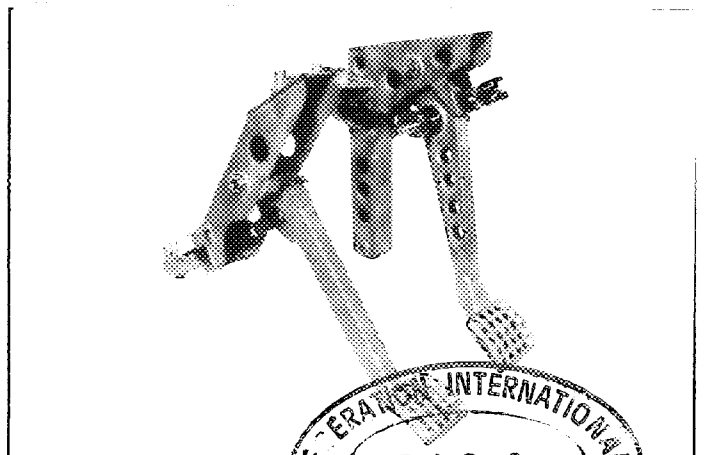

PHOTO 93-66



Make 会社名 MAZDA Model 型式 FAMILIA GT-R No Homol. A-5473

No Ext. 02/02V0

JAF公認番号 JA-151 VO- 2/2

PHOTO 93-67

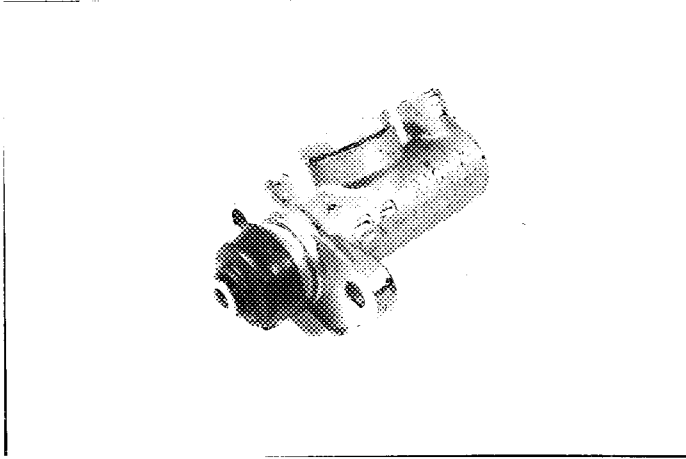

PHOTO 93-68

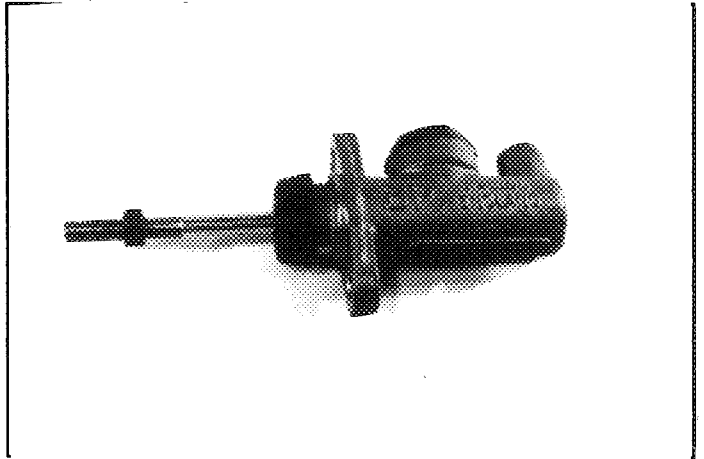

PHOTO 93-69

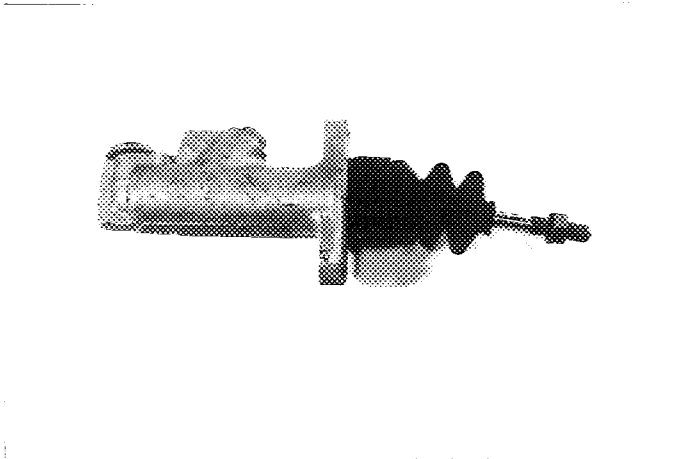

PHOTO 93-70

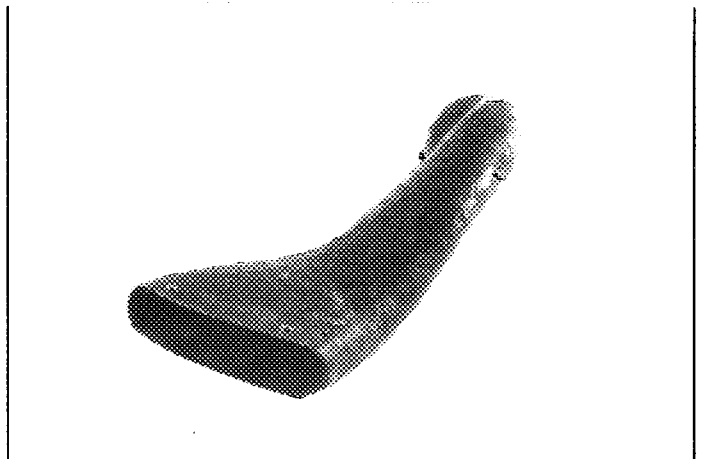
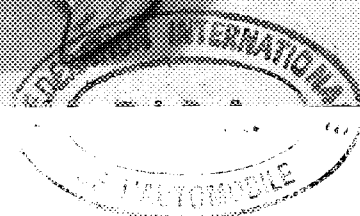

PHOTO 93-71



PHOTO 93-72



Make MAZDA Model FAMILIA GT-R No Homol. A-5473  
会社名 型式

No Ext. 02/02V0

JAF公認番号 JA-151 VO- 2/2

PHOTO 93-73

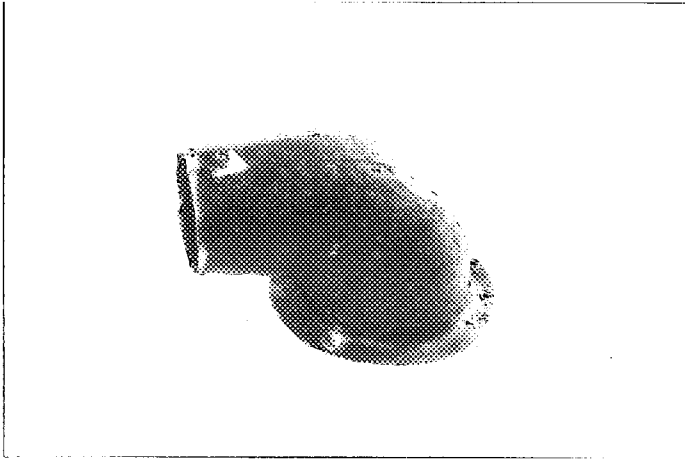

PHOTO 93-74

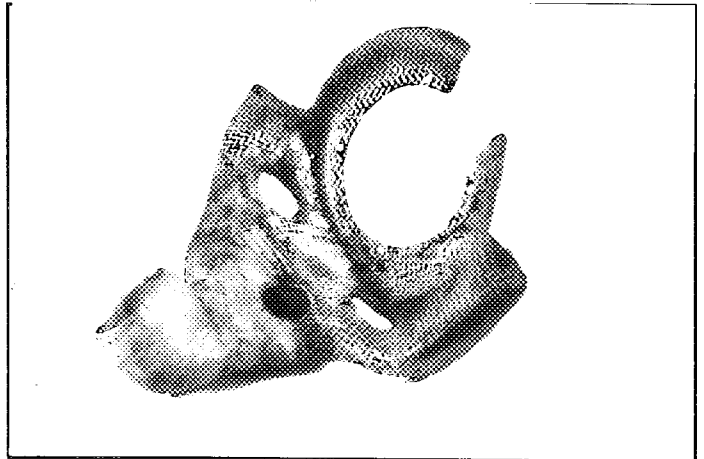

PHOTO 93-75

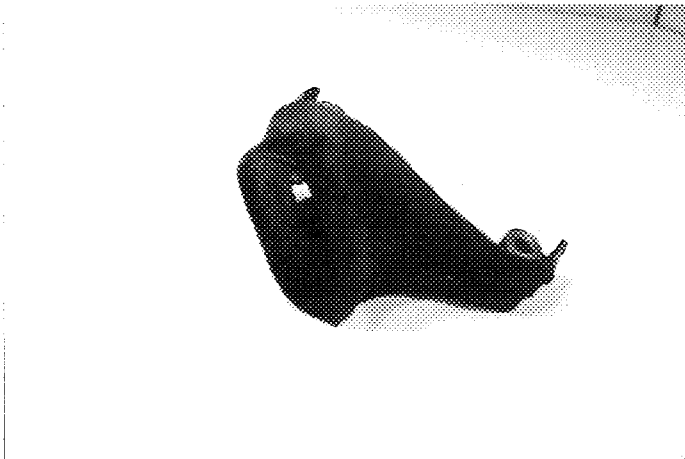

PHOTO 93-76

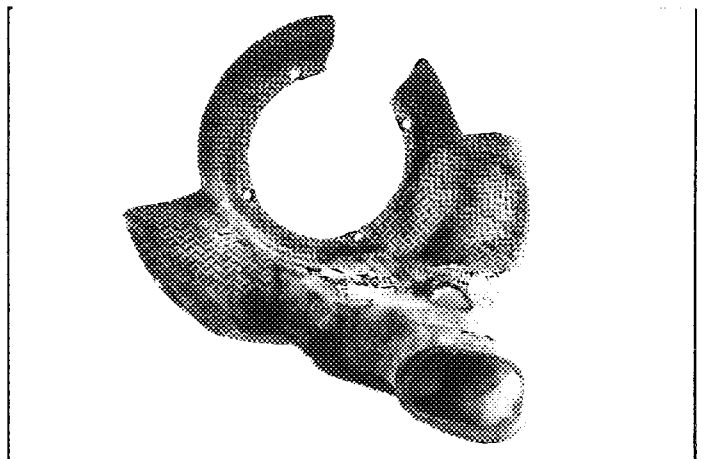
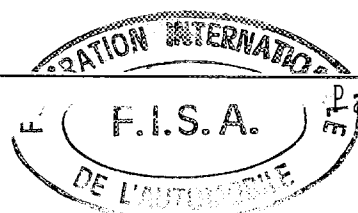
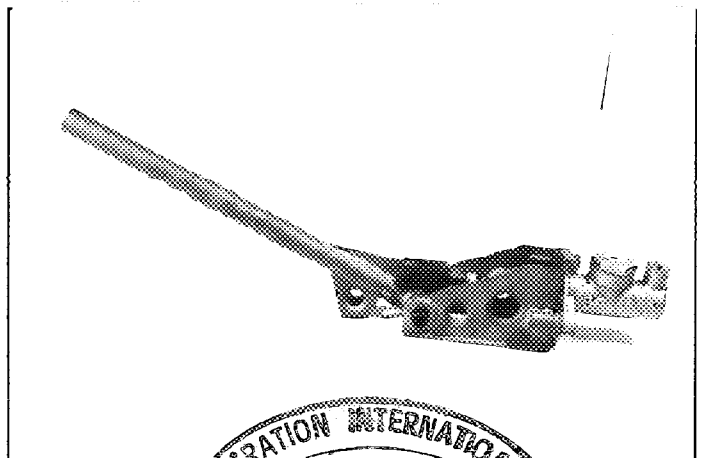

PHOTO 93-77



PHOTO 93-78



Make  
会社名

MAZDA

Model  
型式

FAMILIA GT-R

No Homol.

~~A-5473~~  
02/02VO

No Ext.

JAF公認番号 JA-151 VO- 2/2

PHOTO 93-79

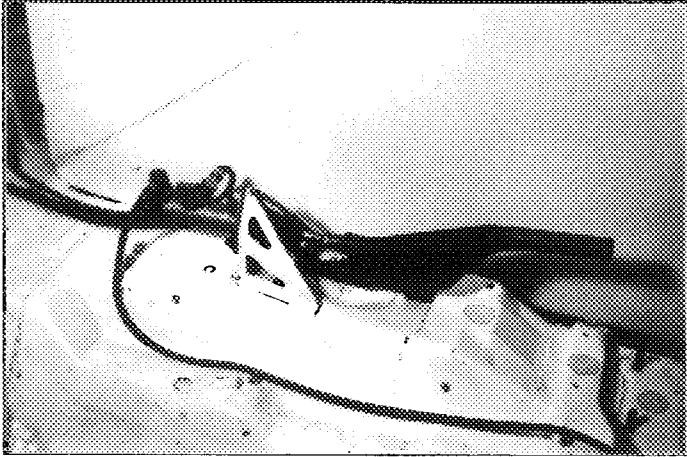

PHOTO 93-80

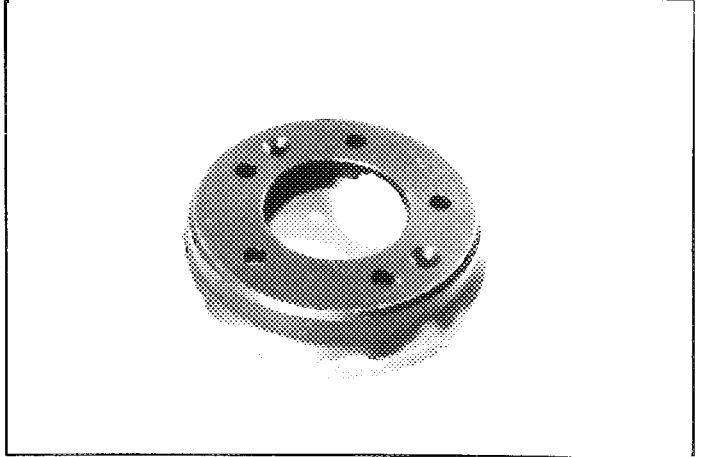

PHOTO 93-81

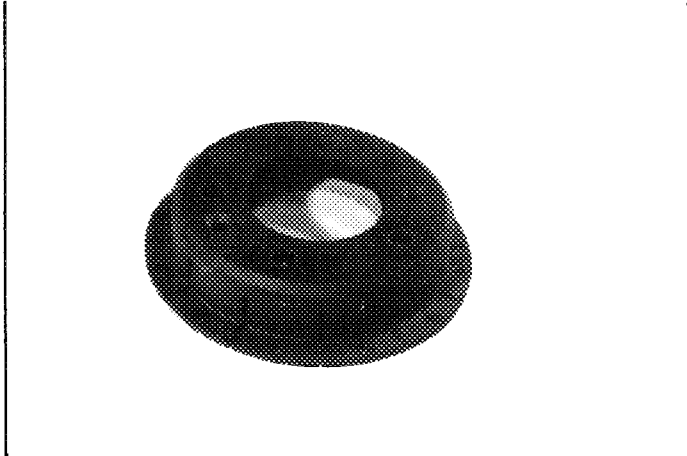

PHOTO 93-82

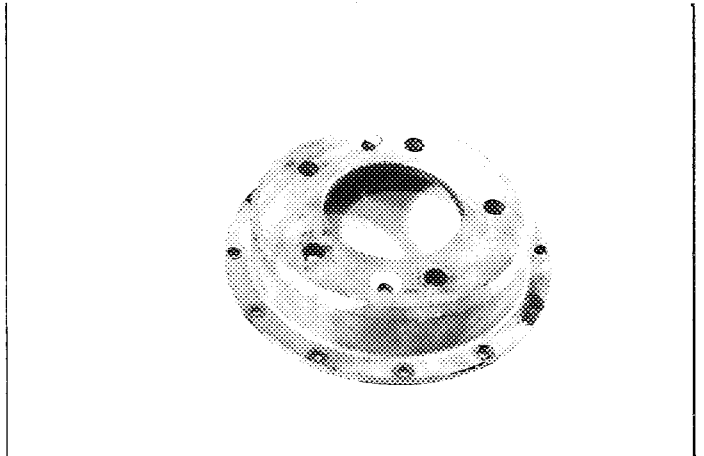

PHOTO 93-83

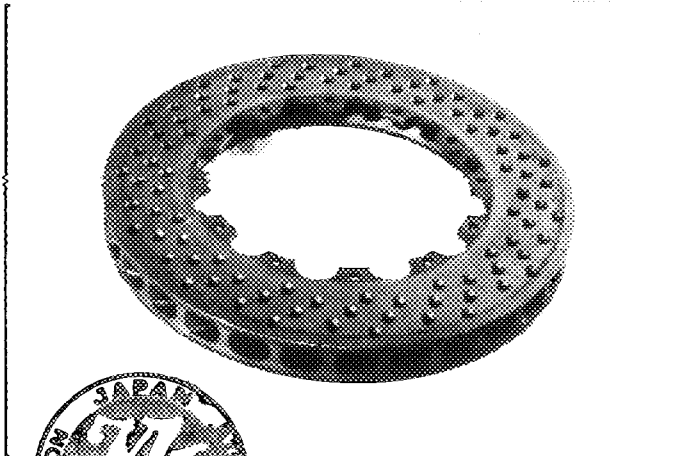

PHOTO 93-84



Make  
会社名

MAZDA

Model  
型式

FAMILIA GT-R

A-5473

No Homol.

No Ext.

02/02VO

JAF公認番号 JA-151 VO- 2/2

PHOTO 93-85

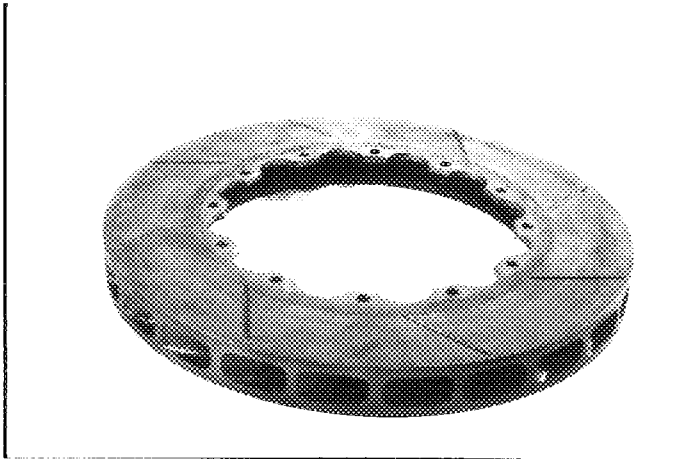

PHOTO 93-86

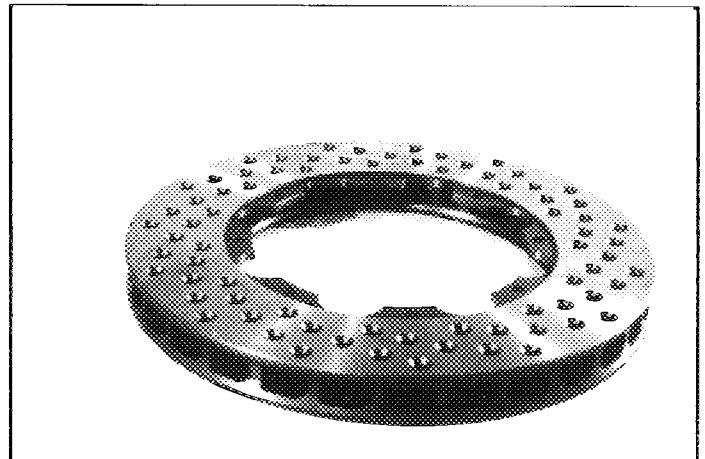

PHOTO 93-87

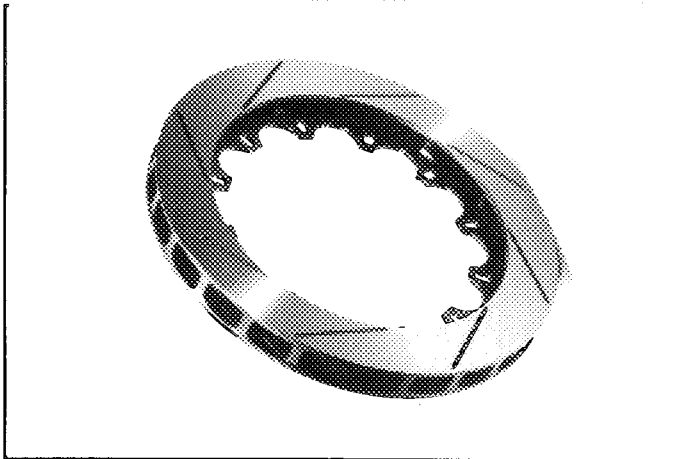

PHOTO 93-88

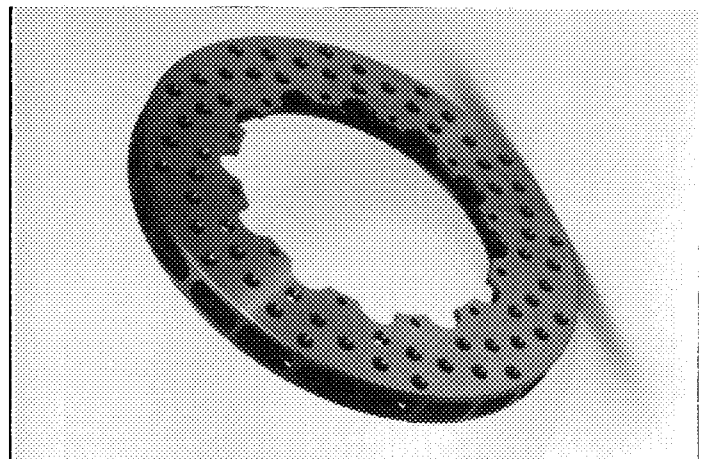

PHOTO 93-89

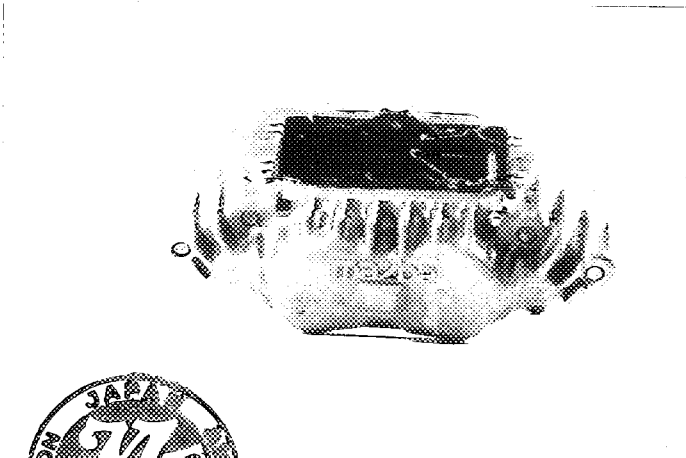
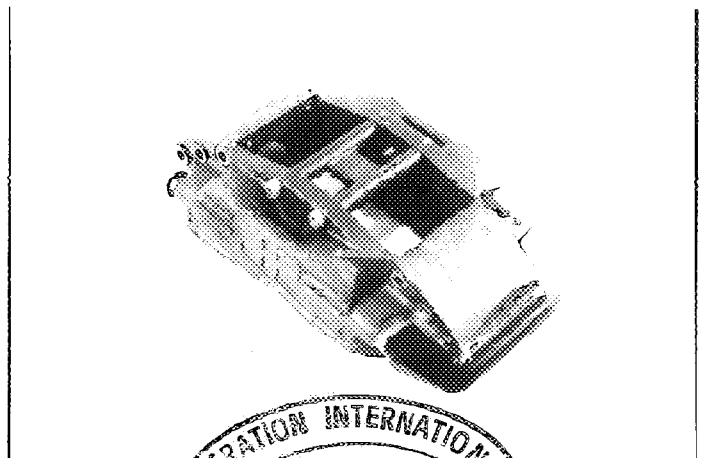

PHOTO 93-90





Make  
会社名

MAZDA

Model  
型式

FAMILIA GT-R

No Homol.

A-5473

No Ext.

~~02/02V0~~

JAF公認番号

JA-151 VO- 2/2

PHOTO 93-91

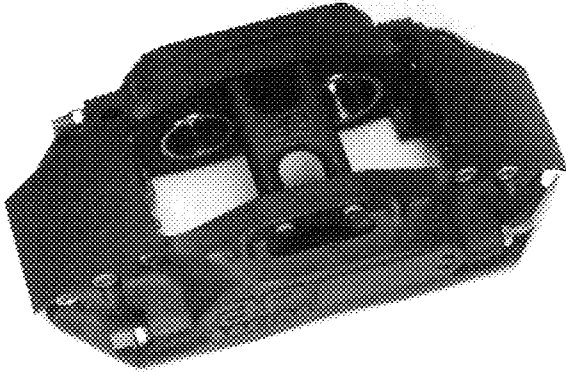

PHOTO 93-92

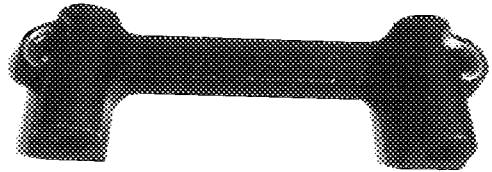

PHOTO 93-93

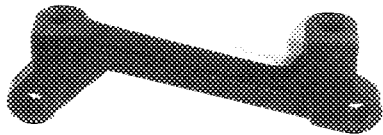

PHOTO 93-94

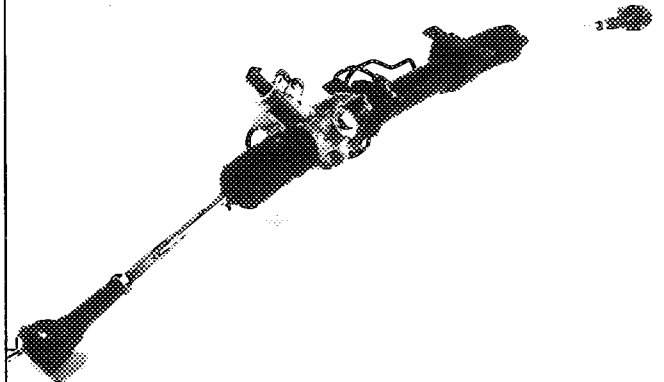

PHOTO 93-95

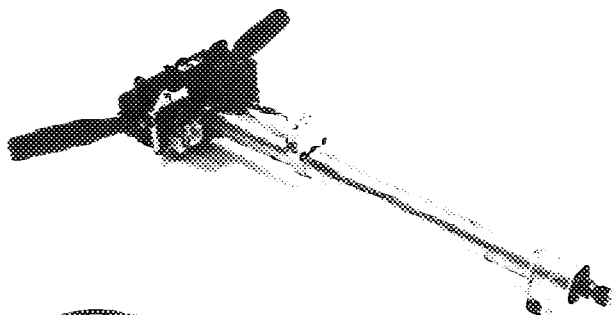
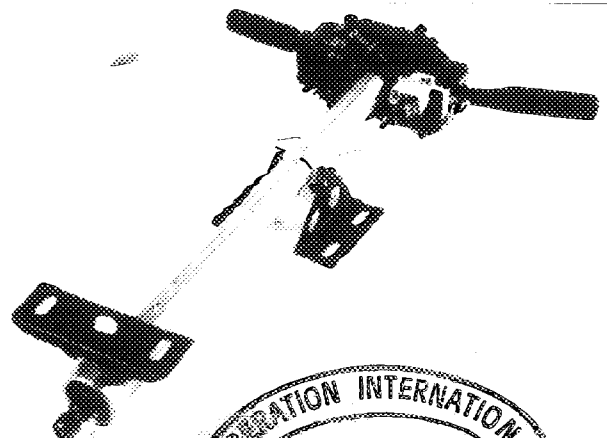

PHOTO 93-96



Make 会社名 MAZDA Model 型式 FAMILIA GT-R No Homol. A-5473

No Ext. 02/02VO

JAF公認番号 JA-151 VO- 2/2

PHOTO 93-97

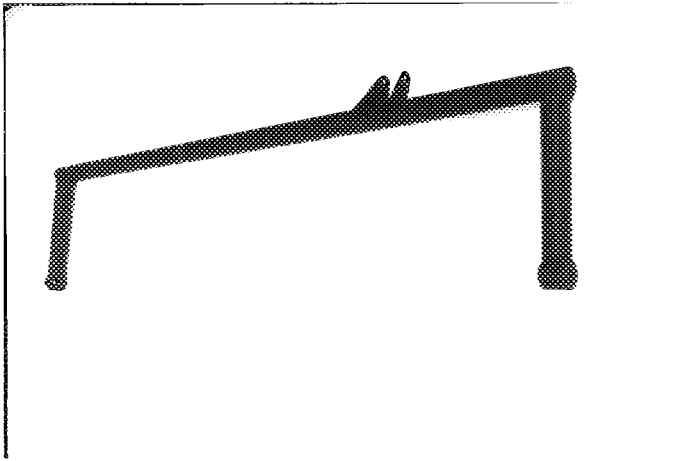

PHOTO 93-98

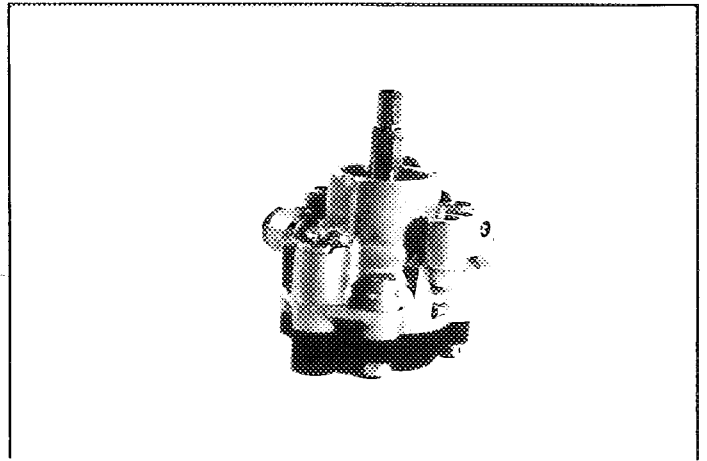

PHOTO 93-99

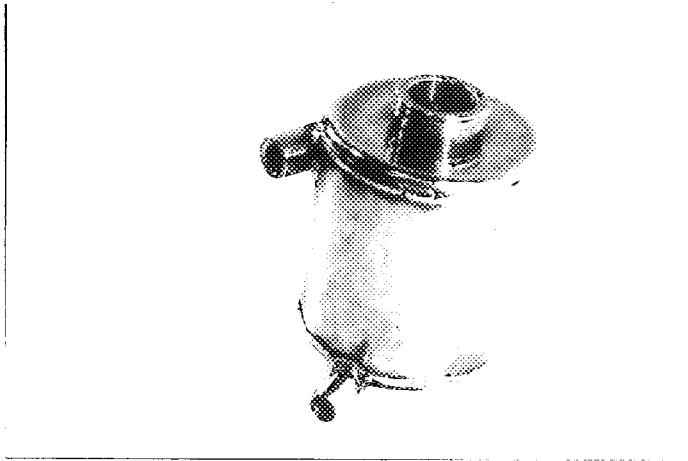

PHOTO 93-100

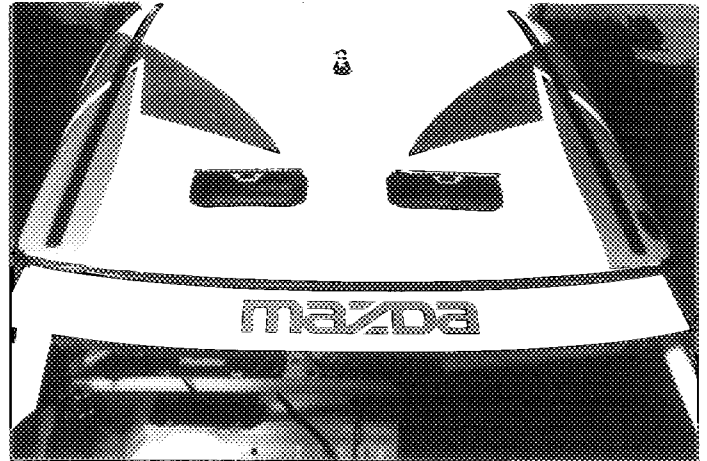

PHOTO 93-101

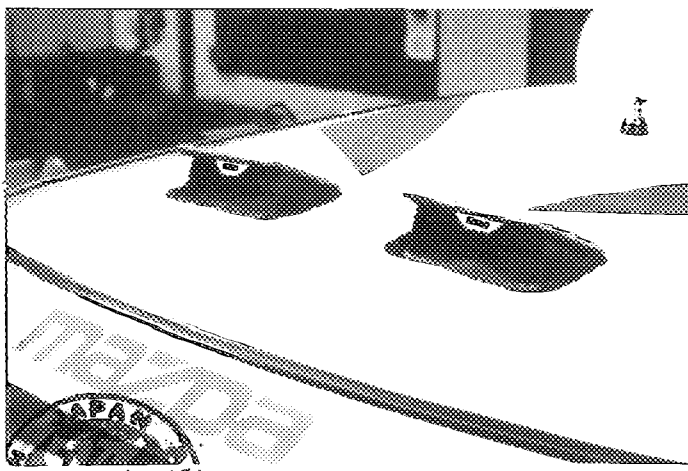
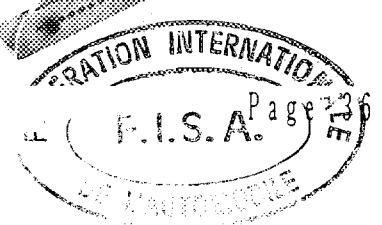
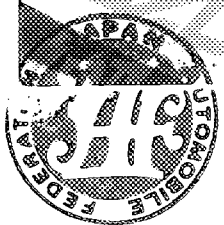
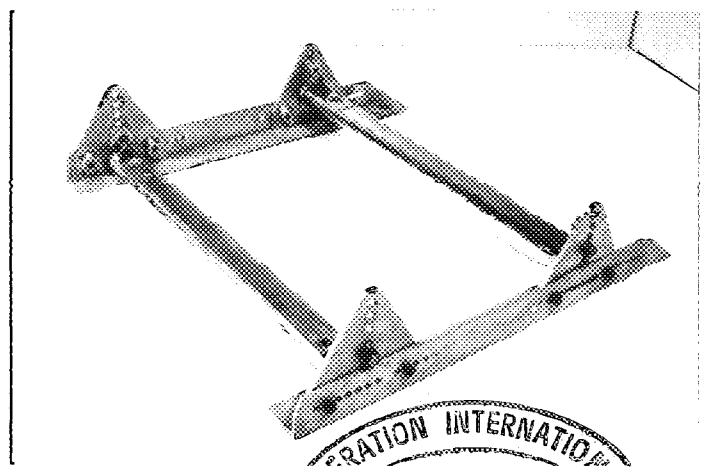

PHOTO 93-102



Make  
会社名

MAZDA

Model  
型式

FAMILIA GT-R

No Homol.

A-5473

No Ext.

02/02V0

JAF公認番号 JA-151 VO- 2/2

PHOTO 93-103

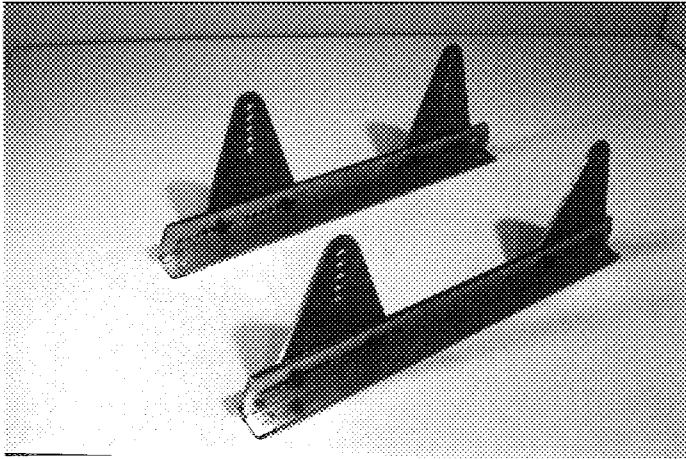

PHOTO 93-104

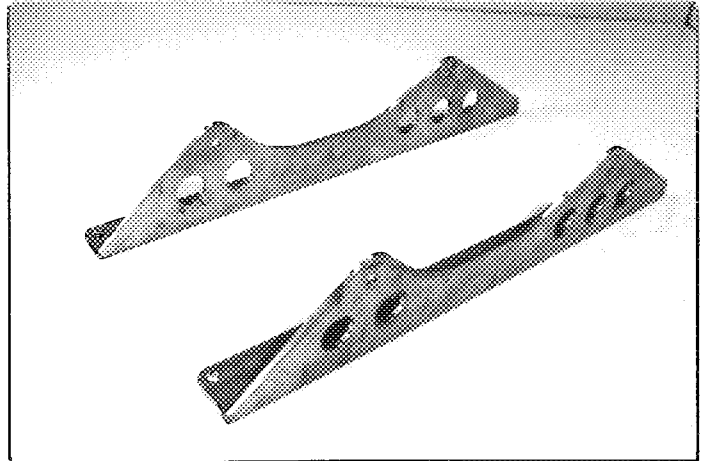

PHOTO 93-105

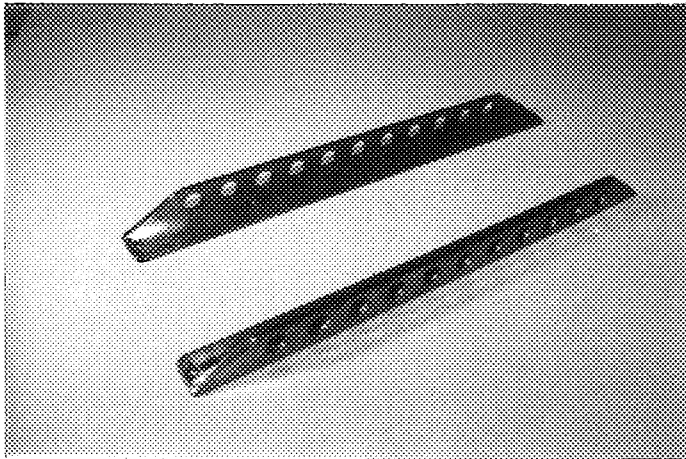

PHOTO 93-106

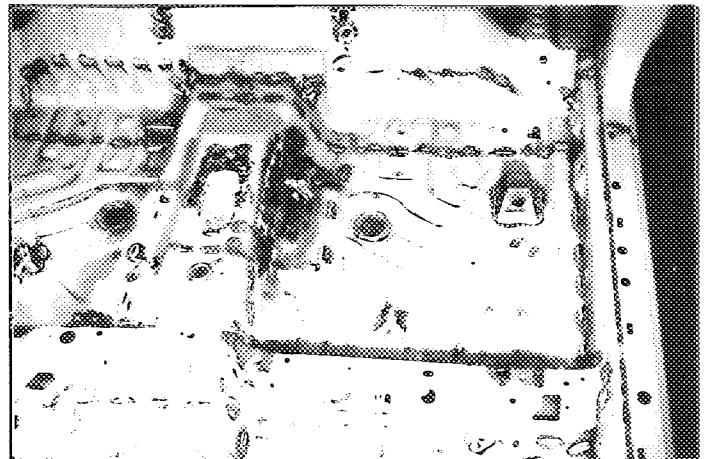

PHOTO 93-107

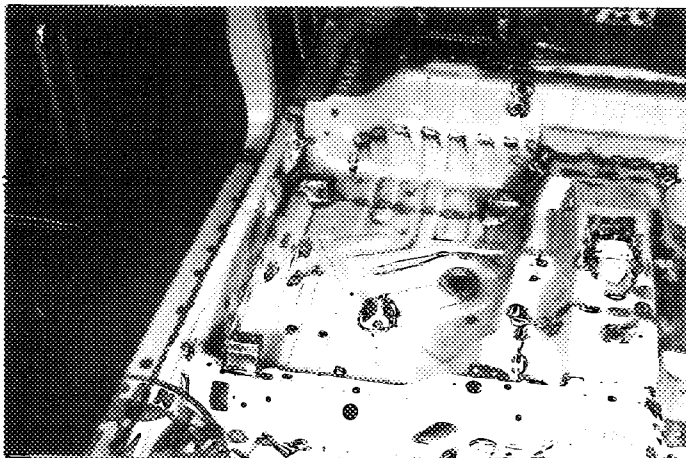
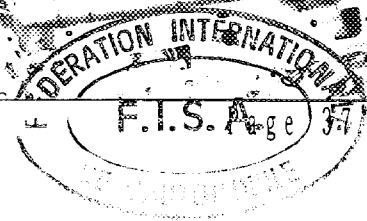
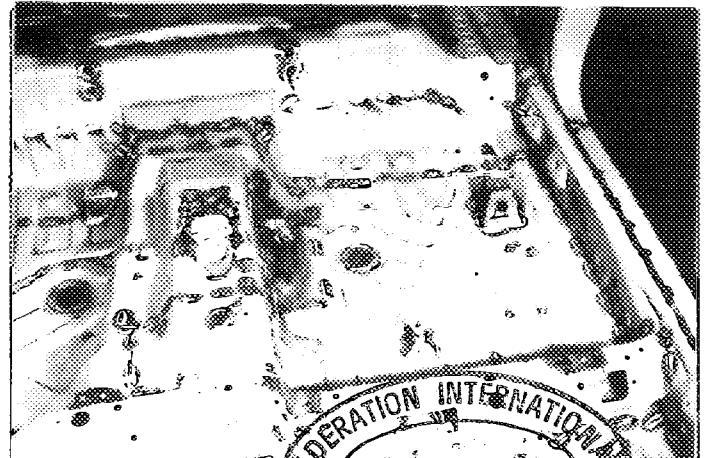

PHOTO 93-108



Mak  
会社名

MAZDA

Model  
型式

FAMILIA GT-R

A-5473

No Homol.

No Ext.

02/02VO

JAF公認番号 JA-151 VO- 2/2

PHOTO 93-109

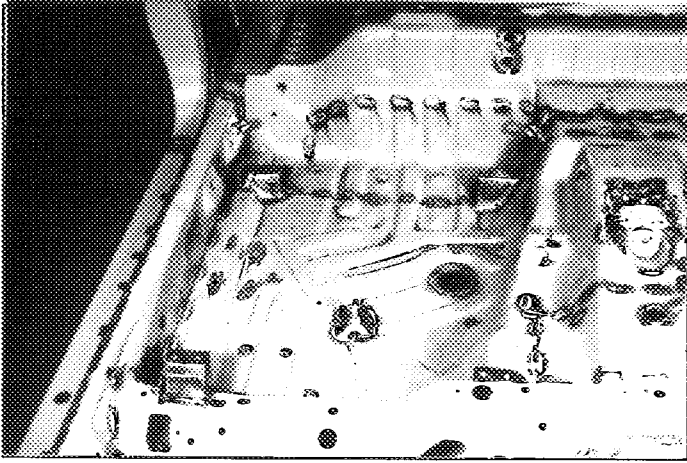
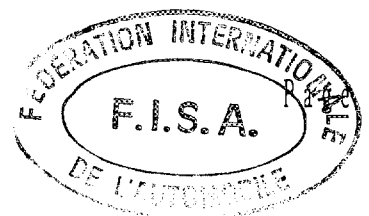
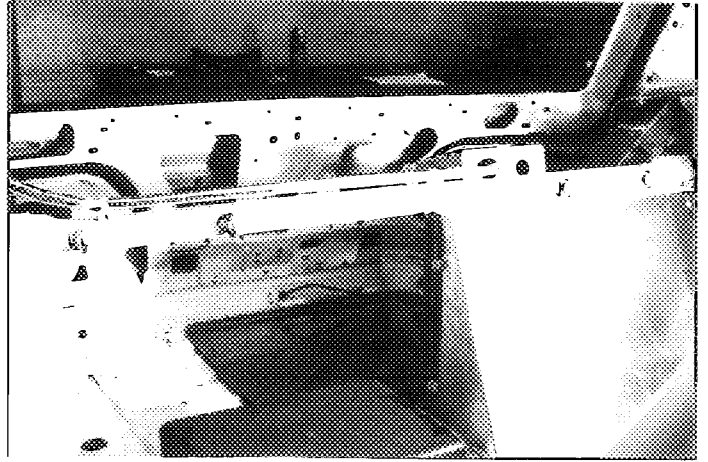
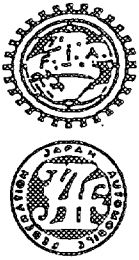

PHOTO 93-110





FEDERATION INTERNATIONALE  
DU SPORT AUTOMOBILE  
JAPAN AUTOMOBILE FEDERATION  
社団法人 日本自動車連盟

JAF公認番号 \_\_\_\_\_  
発効年月日 \_\_\_\_\_

FISA Homologation No

A - 5473

Extension No

03/03V0

FORM OF EXTENSION TO THE OFFICIAL FISA HOMOLOGATION  
FISA公認追加書式

- ES Sporting evolution of the type / スポーツ進化
- ET Normal evolution of the type / 形式の正常進化
- VF Supply variant / 供給変型
- VO Option variant / オプション変型
- ER Erratum / 誤記訂正

Homologation valid as from  
公認発行日

01 AVR. 1993

in group

FISAグループ A

Manufacturer

製造者 MAZDA MOTOR CORPORATION

Model and type

型式と形式 MAZDA FAMILIA GT-R 4WD (BG8)

Page or ext. ページまたは補足	Art. 項目	Description 記述
15	7	SUSPENSION
	701	HEAVY DUTY WHEEL HUB (FRONT/REAR) TYPE C PHOTO 93-111
16, 17	8	RUNNING GEAR
	803	BRAKE DISK BELL (FRONT/REAR) TYPE D PHOTO 93-112

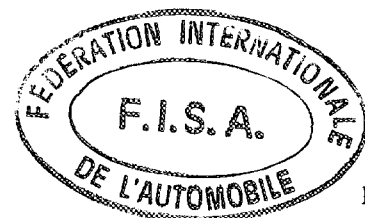

Make  
会社名

MAZDA

Model  
型式

FAMILIA GT-R

No Homol.

A-5473

No Ext.

03/03V0

JAF公認番号

PHOTO 93-111

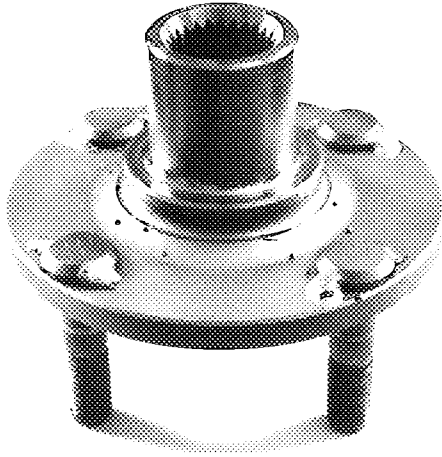

PHOTO 93-112

